

INSTRUCTIONS AND RECOMMENDATIONS FOR THE USE, INSTALLATION AND MAINTENANCE OF BUILT-IN GAS CERAMIC HOBS

Dear customer,

thank you for buying one of our products.

We are sure that this new, modern, functional and practical appliance, made using the finest quality materials, will fully satisfy your requirements. This new appliance is very easy to use, but in order to obtain the best results, we strongly recommend that you read this booklet carefully before use.

These instructions are valid exclusively for countries the identification symbols of which appear on the cover of the instruction booklet and the label on the appliance.

The manufacturer cannot be considered responsible for any damages to people or to things in the event of incorrect installation or improper use of the appliance.

Kuppersbusch USA

1883 Massaro Blvd. Tampa, FL 33619

Toll: (800) 459-0844 P: 813-288-8890 F: 813-288-8604

The logo for Küppersbusch, featuring the brand name in a white, sans-serif font inside a red rounded rectangle.

THE FUTURE OF COOKING SINCE 1875

MODELS: GKS 3720.0 M-UL - GKS 6740.0 M-UL - GKS 9751.0 M-UL

The Manufacturer cannot be held responsible for any imprecision due to printing or copying errors contained in this booklet. The figures shown are purely indicative. We reserve the right to make any changes to our products which we consider to be necessary or useful, also in the interest of the user, without affecting their essential characteristics in terms of functionality and safety.

COD. 04064ULKUP - 04.06.2009

DESCRIPTION OF HOBS

MODEL: GKS 3720.0 M-UL

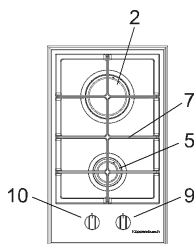

MODEL: GKS 6740.0 M-UL

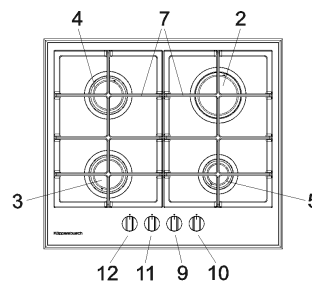

MODEL: GKS 9751.0 M-UL

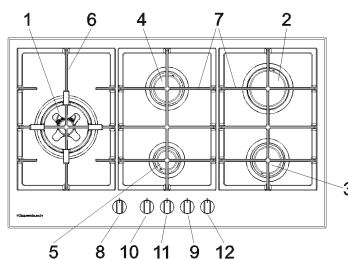

1	“DUAL” burner total simmer	13000 ÷ 14500 Btu/h 2550 ÷ 3200 Btu/h
2	Fast burner	8350 Btu/h
3	Semi fast-burner front	4350 Btu/h
4	Semi fast-burner back	4350 Btu/h
5	Auxiliary burner	3400 Btu/h
6	1F “DUAL” grill	
7	2F grill	
8	Burner no. 1 control knob	
9	Burner no. 2 control knob	
10	Burner no. 5 control knob	
11	Burner no. 4 control knob	
12	Burner no. 3 control knob	

Attention: this appliance has been manufactured for domestic use only and its employment by private person.

SAFE GUARD INSTRUCTIONS

1) SAFE GUARD INSTRUCTIONS

For all appliances:

- the product shall be installed according with the a statement that the installation must conform with local codes or, in absence of local codes, with the *National Fuel Gas Code, ANSI Z223.1/NFPA 54*.
- The product must be electrically grounded in accordance with local codes or, in the absence of local codes, with the *National Electrical Code, ANSI/NFPA 70*.
- The appliance and its individual shutoff valve must be disconnected from the gas supply piping system during any pressure testing of that system at test pressure in excess of ½ psi (3.5 kPa). The maximum gas supply pressure is 4 inch WC and 11 inch WC and the gas pressure regulator provided is regulated to 1 inch water column above the manufacturer's specified manifold pressure.
- Always disconnect all cord connect appliances shall include instructions relative to location of the wall receptacle and the warning to the user to disconnect the electrical supply before servicing the appliance.

WARNING: If the information on this manual is not followed exactly, a fire or explosion may result causing property damage, personal injury or death.

- Do not store or use gasoline or other flammable vapors and liquids in the vicinity of this or any other appliance.
 - **WHAT TO DO IF YOU SMELL GAS**
 - Do not try to light any appliance.
 - Do not touch any electrical switch; do not use any phone in your building.
 - Immediately call your gas supplier from a neighbor's phone.
Follow the gas supplier's instructions.
 - If you cannot reach your gas supplier, call the fire department.
 - Installation and service must be performed by a qualified installer; service agency or the gas supplier.
-
- Save the orifices removed from the appliance for future use.
 - When a flexible service cord of the grounding type is provided to connect the appliance to a line-voltage electrical supply, the instructions shall also include the intent of the warning statement specified in 1.29.12.
 - The maximum depth cabinets installed above cooking tops be 13 in. (330 mm).
 - Keeping appliance area clear and free from combustible materials, gasoline, and other flammable vapors and liquids.
 - Not obstructing the flow combustion and ventilation air.

USE

2) BURNERS

A diagram is screen-printed above each knob on the front panel. This diagram indicates to which burner the knob in question corresponds. After having opened the gas mains or gas bottle tap, light the burners as described below:

- manual ignition

Push and turn the knob corresponding to the required burner in an anticlockwise direction until it reaches the full on position (large flame fig. 1), then place a lighted match near the burner.

- Electrical ignition

Push and turn the knob corresponding to the required burner in an anticlockwise direction until it reaches the full on position (large flame fig. 1), then depress and release the ignition button "E".

- Automatic electrical ignition

Push and turn the knob corresponding to the required burner in an anticlockwise direction until it reaches the full on position (large flame fig. 1), then depress the knob.

- Lighting burners equipped with flame failure device

The knobs of burners equipped with flame failure device must be turned in an anticlockwise direction until they reach the full on position (large flame fig. 1) and come to a stop. Now depress the knob in question and repeat the previously indicated operations.

Keep the knob depressed for about 10 seconds once the burner has ignited.

HOW TO USE THE BURNERS

Bear in mind the following indications in order to achieve maximum efficiency with the least possible gas consumption:

- use adequate pans for each burner (consult the following table and fig. 2).
- When the pan comes to the boil, set the knob to the reduced rate position (small flame fig. 1).
- Always place a lid on the pans.
- Use only pan with a flat bottom.

Burners	Power ratings BTU	Pan Ø in cm
"DUAL" burner total simmer	13000÷14500 Btu/h 2550÷3200 Btu/h	24 ÷ 26
Fast burner	8350 Btu/h	20 ÷ 22
Semi fast-burner front	4350 Btu/h	16 ÷ 18
Semi fast-burner back	4350 Btu/h	16 ÷ 18
Auxiliary	3400 Btu/h	10 ÷ 14

WARNINGS:

- **burners with flame failure device may only be ignited when the relative knob has been set to the Full on position (large flame fig. 1).**
- **Matches can be used to ignite the burners in a blackout.**
- **Never leave the appliance unattended when the burners are being used. Make sure there are no children in the near vicinity. Particularly make sure that the pan handles are correctly positioned and keep a chek on foods requiring oil and grease to cook since these products can easily catch fire.**
- **The machine must not be used by people (including children) with impaired mental or physical capacities, or without experience of using electrical devices, unless supervised or instructed by an expert adult responsible for their care and safety. Children should not be allowed to play with the equipment.**
- **Never use aerosols near the appliance when it is operating.**
- **If the built-in hot plate has a lid, any spilt food should be immediately removed from this before it is opened. If the appliance has a glass lid, this could shatter when the hot plate becomes hot. Always switch off all the burners before closing the lid.**
- **Containers wider than the unit are recommended.**

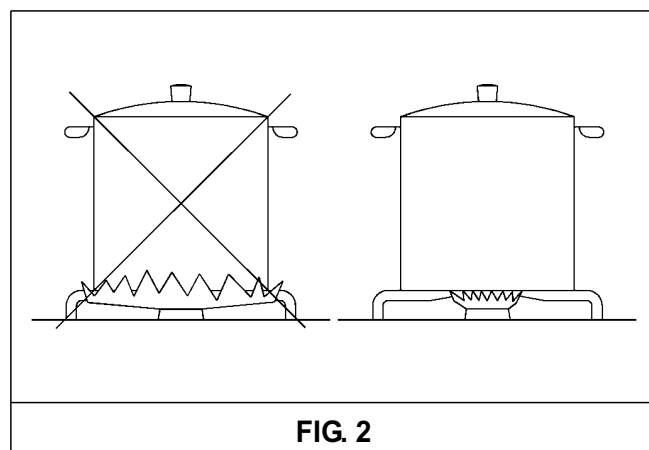
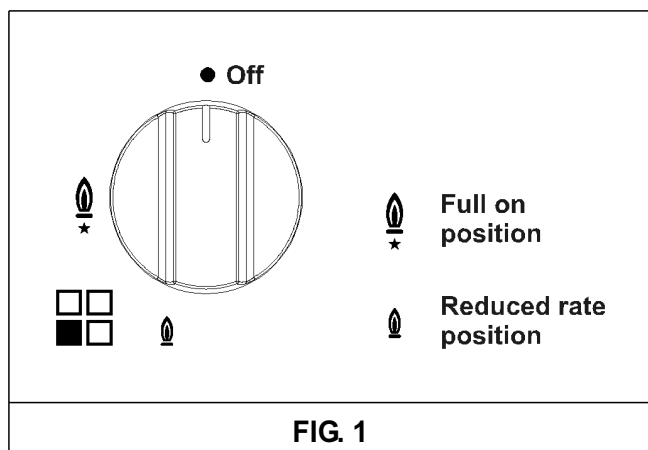

USE

3) TRADITIONAL BURNERS

On the surface of the hob, there is a serigraphic figure above each knob, indicating the burner to which the knob refers. After turning on the gas at the main or opening the valve on the gas bottle, light the burners as indicated below:

- automatic electric ignition

Press the knob corresponding to the burner to use and turn it clockwise to the "Maximum" position (big flame fig. 1) pressing the knob right down.

- Lighting burners fitted with a safety cut-off device

For burners fitted with a safety cut-off device, turn the knob corresponding to the burner to use anti-clockwise to the "Maximum" position (big flame fig. 1) until it stops and then press the knob. Continue pressing the knob for about 10 seconds after the burner has been lit.

Should the flames accidentally go out, turn the burner control knob off and wait at least 1 min before attempting to light it again.

How to use the burners

To obtain maximum performance with minimum gas consumption, remember the following:

- use suitable pans for each burner (see the table below and fig. 2).
- When boiling point is reached, turn the knob to the "Minimum" position (small flame fig. 1).
- Always use pans with lids.

"DUAL" burner:

separate regulation of the inner and outer rings (in practical terms, a dual burner controlled by a single knob), offering very flexible use thanks to the possibility to light either the inner flame only or the whole burner (inner and outer flame at the same time).

LIGHTING AND USING THE "DUAL" BURNER

Stand the pan on the burner before lighting.

Despite being controlled by a single knob, the "DUAL" burner can be used in two different ways.

A) - Using the complete burner:

Starting from the off position ● You must first press the knob, simultaneously turning it anti-clockwise,

until the indicator points to the maximum delivery position ★ obtaining the maximum flow capacity of both flames.

When the flames are lit, keep the knob pressed for a few seconds, until the device automatically keeps the burner lit.

It is now possible to regulate the intensity of the flame by turning the knob anti-clockwise (from the maximum flow capacity position of the inner and outer flames to the maximum flow capacity of the inner flame and the minimum of the outer flame.

To turn off the burner, turn the knob clockwise, realigning the indicator with the ● off symbol.

B) - Using the inner flame only:

after lighting the burner and regulating the inner flame to maximum flow capacity and the outer flame to minimum flow capacity as described above, turn the knob anti-clockwise until it clicks once. The inner flame is now at maximum flow capacity while the outer flame is turned off.

Continue turning anti-clockwise to regulate the inner flame to the minimum flow capacity.

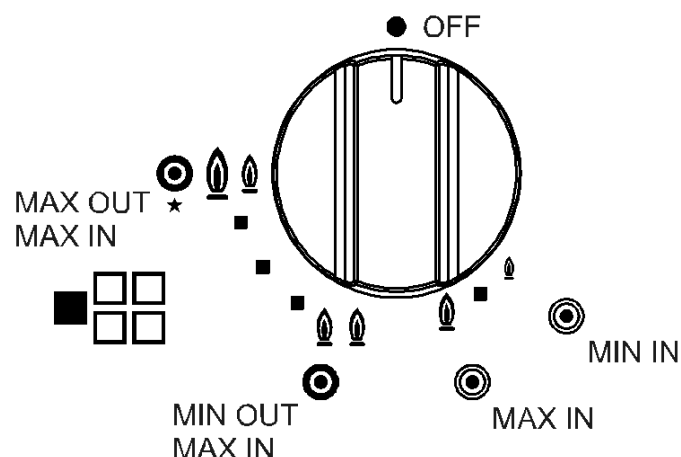

Turning off:

to turn off the burner, turn the knob clockwise, realigning the indicator with the ● off symbol.

Once the "DUAL" burner is operating in either of the two modes described, it is possible to swap from one mode to the other by simply pressing and turning the knob to the position required:

USE

Notes:

use of a gas cooking appliance produces heat and moisture in the room in which it is installed. The room must therefore be well ventilated.

Intensive and lengthy use of the appliance may require additional ventilation. This can be achieved by opening a window or by increasing the power of the mechanical exhausting system if installed.



WARNING!

NEVER use this appliance as a space heater to heat or warm the room. Doing so may result in carbon monoxide poisoning and overheating of the oven.

CLEANING

CAUTION:

before cleaning the appliance, disconnect it from the gas and electricity supplies.

4) WORKTOP

If you wish to maintain the shine of the ceramic surface, treat the glass with a silicon-based film product before use to protect the surface against water and dirt. This protective film is not durable, so it is advisable to repeat the application of the product frequently.

It is very important to clean the hob every time you use it, while the glass is still warm.

Do not clean using abrasive metal scourers, powder abrasives or corrosive sprays.

Depending on the degree of dirt, we recommend:

- for light stains, a damp sponge is sufficient.
- Tough, encrusted dirt is easily eliminated using a scraper (fig. 3), not supplied with the hob, but easy to find in local stores. ***Use the scraper carefully to avoid damaging the hob.***

- Traces of liquid spilled from pans can be eliminated with vinegar or lemon juice.
- ***Never allow sugar or sugary foods to fall on the hob while cooking. Should this occur, switch off the hob and clean it immediately with hot water, using a scraper on hot spills.***
- As time goes by metallic reflections, colouring or scratches may appear due to poor cleaning and the incorrect movement of pans. Scratches are hard to eliminate but do not affect the correct operation of your hob.
- Do not use jets of steam to clean the appliance.



FIG. 3

CLEANING

The enamelled grids, enamelled covers "A", "B" and "C", and burner heads "M" (see fig. 4 and 4/A) must also be washed and the ignition elements "AC" and safety cut-off sensors "TC" (see fig. 4/B) must be cleaned. Do not wash them in the dishwasher. Cleaning operations must be carried out when the hob and components are not hot and the use of metal scouring pads, powder abrasives and corrosive sprays must be avoided. Do not allow vinegar, coffee, milk, salt water, lemon juice or tomato juice to remain in prolonged contact with the surfaces.

WARNINGS:

when reassembling the components, observe the following recommendations:

- check that the holes in the burner heads "M" (fig. 4) are not blocked by foreign bodies.
- Ensure that the enamelled covers "A", "B" and "C" (fig. 4 and 4/A) are correctly positioned on the burner head. The covers are correctly positioned on the head when they are perfectly stable.

- If the opening and closing of any valve is awkward, do not force it but request urgent intervention by the technical assistance service.

- Do not use jets of steam to clean the appliance.

- To prevent difficulties with lighting, regularly clean the ignition elements (ceramic and electrode) and safety cut-off devices.

IMPORTANT:

when removing the burners to clean them, ensure that all parts are correctly positioned before relighting them. In particular for the "Dual" burner, **never remove the central disc underneath the lid (particular A - fig. 5), for cleaning.** Should this operation be necessary, it must be carried out exclusively by qualified personnel.

Do not remove the metal disc "B" screwed onto the burner.

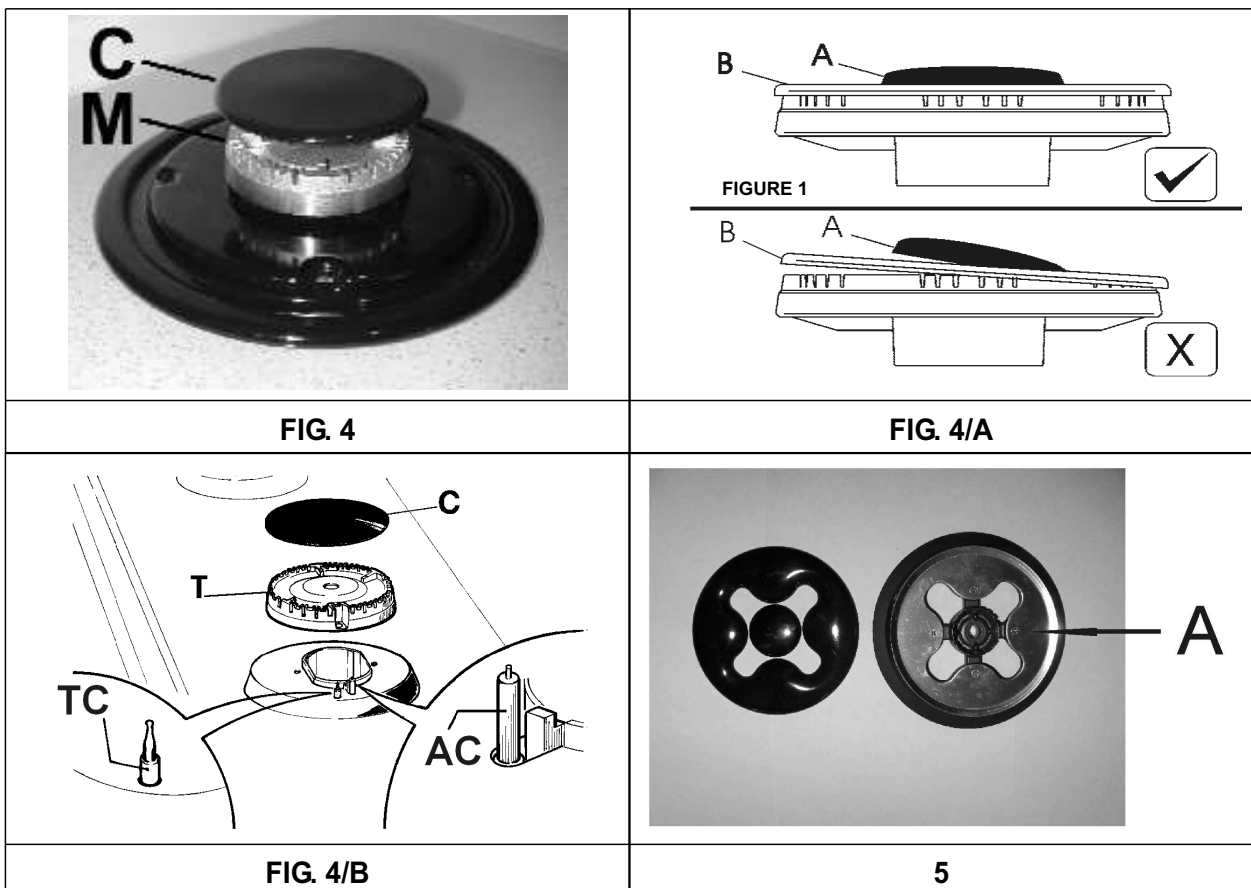

INSTALLATION

TECHNICAL INFORMATION FOR THE INSTALLER

Installation, adjustments of controls and maintenance must only be carried out by a qualified engineer.

Incorrect installation may cause damage to persons, animals or property for which the Manufacturer shall not be considered responsible.

During the life of the system, the automatic safety or regulating devices on the appliance may only be modified by the manufacturer or by his duly authorized dealer.

4) INSTALLING THE WORKTOP

Check that the appliance is in a good condition after having removed the outer packaging and internal wrappings from around the various loose parts. In case of doubt, do not use the appliance and contact qualified personnel.

Never leave the packaging materials (cardboard, bags, polystyrene foam, nails, etc.) within children's reach since they could become potential sources of danger.

The measurements of the opening made in the top of the modular cabinet and into which the hot plate will be installed are indicated in either fig. 6. Always comply with the measurements given for the hole into which the appliance will be recessed (see fig. 6 and 7).

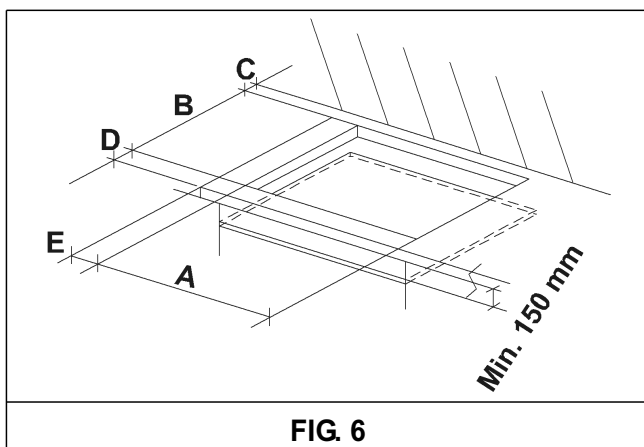

5) FIXING THE HOT PLATE

The hot plate has a special seal which prevents liquid from getting into the cabinet. Strictly comply with the following instructions in order to correctly apply this seal:

- detach the seals from their backing, checking that the transparent protection still adheres to the seal itself.
- Evenly and securely fix the seal to the hot plate, pressing into place with the fingers and remove the strip of protective paper from the seal and set the plate into the hole made in the cabinet.
- The prospective walls (left or right) that exceed the working table in height must be at a minimum distance from the cutting as mentioned both in the columns and the scheme.
- In order to avoid accidental touch with the overheating bottom of the hob, during the working, is necessary to put a wooden insert, fixed by screws, at a minimum distance of 150 mm from the lower surface of the top (see fig. 6).

COMPLY WITH THE DIMENSIONS (in mm)

	A	B	C	D	E
2F (30)	285	485	57.5	57.5	73 min.
4F (60)	553	473	63.5	63.5	73 min.
5F (90)	833	475	62.5	62.5	73.5 min.

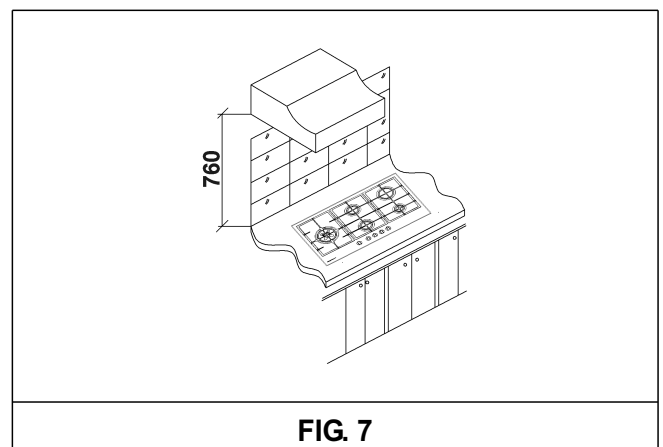

INSTALLATION

6) FITTING THE HOB

The hob is equipped with a special seal to avoid any infiltration of liquid into the unit. To apply this seal correctly, please follow the instructions given below carefully:

- remove all the mobile parts of the hob.
- Cut the seal into 4 strips of the lengths suitable to fit it along the 4 sides of the glass.
- Turn the hob upside down and place the adhesive side of the seal "E" (fig. 8) correctly under the edge of the hob so that the outer edge of the seal perfectly matches the outer perimeter edge of the glass. The ends of the strips must match without overlapping.

- Stick the seal to the glass evenly and securely, using your fingers to press it into place.
- In order to avoid accidental contact with the surface of the box of the overheated hob during use, it is necessary to install a wooden divider at a minimum distance of 150 mm from the top, fastening it in place with screws. (fig. 6).
- To fasten this product to the supporting structure, we advise you not to use mechanical or electrical screwdrivers and to exercise moderate pressure by hand on the fastening hooks.

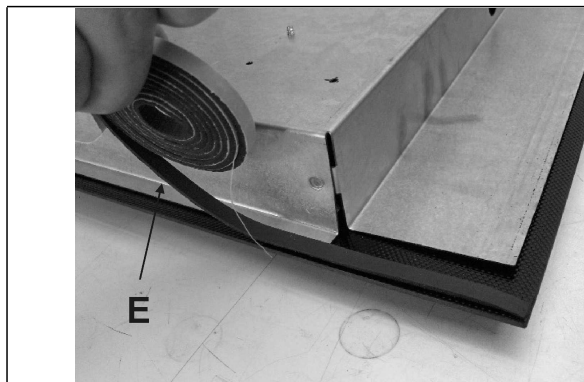

FIG. 8

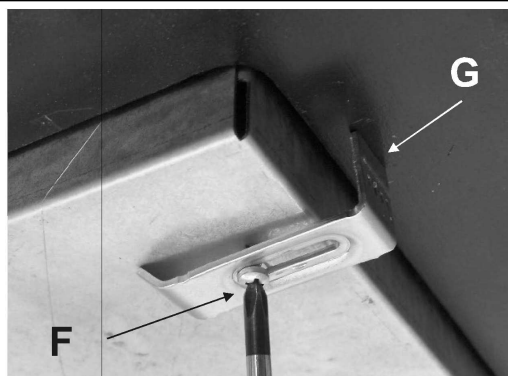

FIG. 9

INSTALLATION

7) ROOM VENTILATION

To ensure correct operation of the appliance, it is important to ensure that the room where the hot plate is installed has sufficient ventilation.

8) GAS CONNECTION

Natural Gas and Propane Gas

Natural Gas installations require the connection of a gas regulator at the appliance. This regulator is supplied with the appliance on purchase.

Assemble the regulator (noting the gas flow direction) and transition pieces (supplied with the appliance), in accordance with below figure.

The transition piece on the supply side of the regulator must be provided by the installer.

Unions compatible with the hose fittings must be used and connections tested for gas leaks.

Ensure the supply connection point is accessible with the appliance installed.

Warning: ensure that the hose assembly is restrained from accidental contact with the flue or flue outlet of an underbench oven.

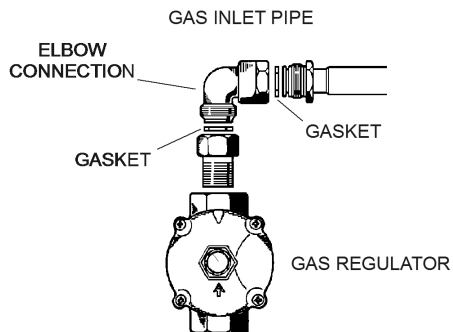

INSTALLATION

9) ELECTRICAL CONNECTION

The electrical connections of the appliance must be carried out in compliance with the provisions and standards in force.

Before connecting the appliance, check that:

- the electrical capacity of the mains supply and current sockets suit the maximum power rating of the appliance (consult the data label applied to the underside of the hot plate).
- The socket or system has an efficient earth connection in compliance with the provisions and standards in force. The manufacturer declines all responsibility for failing to comply with these provisions.

When the appliance is connected to the electricity main by a socket:

- fit a standard plug suited to the load indicated on the data label to the cable.
- Fit the wires following figure 10, taking care of respecting the following correspondences:

Letter L (live) = wire;

Letter N (neutral) = wire;

earth symbol  = green or yellow-green wire.

- Never use reductions, adapters or shunts for connection since these could create false contacts and lead to dangerous overheating.
- The outlet must be accessible after the built-in.

When the appliance is connected straight to the electricity main:

- install an omnipolar circuit-breaker between the appliance and the electricity main. This circuit-breaker should be sized, in compliance with current installation regulations.
- Remember that the earth wire must not be interrupted by the circuit-breaker.
- For optimum safety, the electrical connection may also be protected by a high sensitivity differential circuit-breaker.

You are strongly advised to fix the relative yellow-green earth wire to an efficient earthing system.

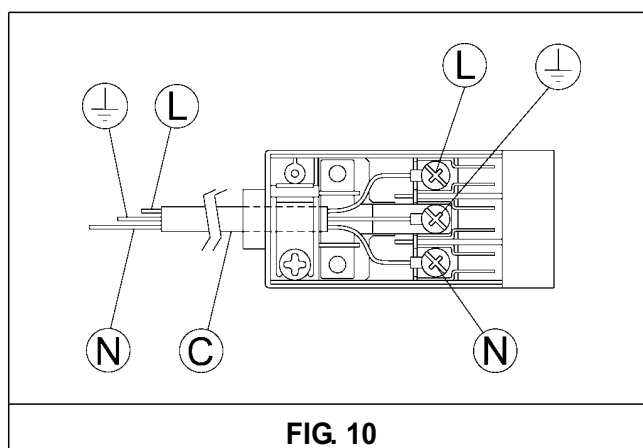

INSTALLATION

10) FIXING THE HOT PLATE

The hot plate has a special seal which prevents liquid from infiltrating into the cabinet. Strictly comply with the following instructions in order to correctly apply this seal:

- detach the seals from their backing, checking that the transparent protection still adheres to the seal itself.
- Overturn the hot plate and correctly position seal "E" (fig. 11) under the edge of the hot plate itself, so that the outer side of the seal perfectly matches the outer perimetral edge of the hot plate. The ends of the strips must fit together without overlapping.
- Evenly and securely fix the seal to the hot plate, pressing into place with the fingers and remove the strip of protective paper from the seal and set the plate into the hole made in the cabinet.

- Fix the hob with the proper brackets "S" and turn the screw "F" until the bracket "S" stick on the top (fig. 12).
- The prospective walls (left or right) that exceed the working table in height must be at a minimum distance from the cutting as mentioned both in the columns and the scheme.
- In order to avoid accidental touch with the overheating bottom of the hob, during the working, is necessary to put a wooden insert, fixed by screws, at a minimum distance of 150 mm from the lower surface of the top (see fig. 6).

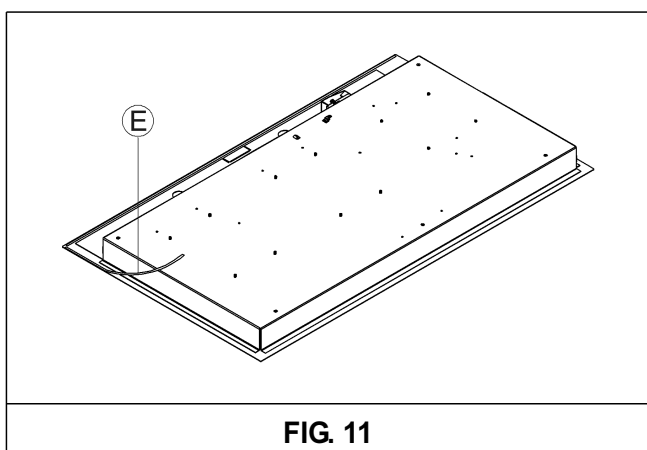

FIG. 11

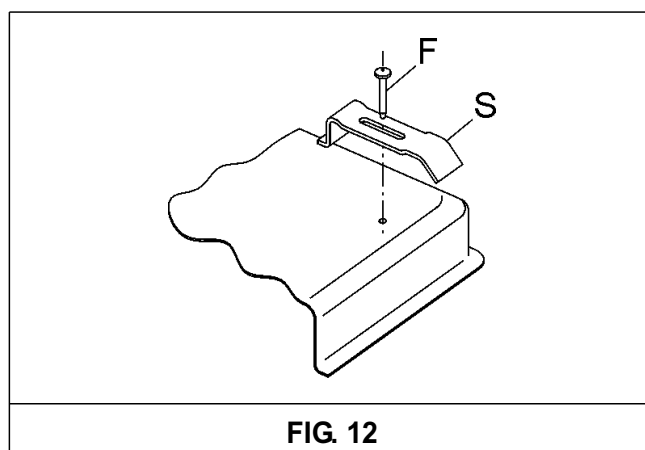

FIG. 12

ADJUSTMENTS

Always disconnect the appliance from the electricity main before making any adjustments. All seals must be replaced by the technician at the end of any adjustments or regulations. Our burners do not require primary air adjustment.

It is understood that only burners operating with Natural Gas or Town gas should be subjected to the above mentioned adjustments. The screw must be fully locked when the burners operate with Propane HD-5 (turn clockwise).

11) TAPS

“Reduced rate” adjustment

- Switch on the burner and turn the relative knob to the “Reduced rate” position (small flame fig. 1).
- Remove knob “M” (fig. 13) of the tap, which is simply pressed on to its rod.
- Insert a small screwdriver “D” into hole “C” (fig. 13) and turn the throttle screw to the right or left until the burner flame has been adequately regulated to the “Reduced rate” position.

Check that the flame does not go out when the knob is sharply switched from the “Full on” to the “Reduced rate” position.

In the case of a “DUAL” burner, the regulation screw situated inside the post of the valve regulates the central flame, while the screw next to the valve regulates the outer flame.

The operations described above can be carried out easily, whatever the position of the hob or however it is fastened to the unit.

THE BURNERS DO NOT REQUIRE ANY REGULATION OF THE PRIMARY AIR.

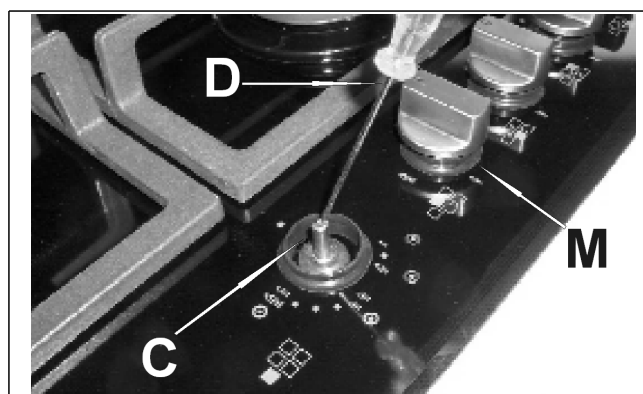

FIG. 13

CONVERSIONS

12) REPLACING NOZZLES

The burners can be adapted to suited different types of gas by fitting the nozzles that correspond to the gas used. To do this, it is necessary to remove the burner heads and use a straight key "B", to unscrew the nozzle "A" (see fig. 14) and replace it with a nozzle corresponding to the gas used.

We advise you to block the nozzle tightly.

After making these replacements, the technician must regulate the burners as described in paragraph 11, seal any regulation

or pre-regulation organs and apply the label corresponding to the new gas regulation carried out on the appliance in place of that previously applied. This label is contained in the spare nozzle bag.

For the ease of the fitter, we have prepared a table indicating the flow capacities, the heat capacities of the burners, the diameter of the nozzles and the working pressure for the various types of gas.

ARRANGEMENT OF THE BURNERS

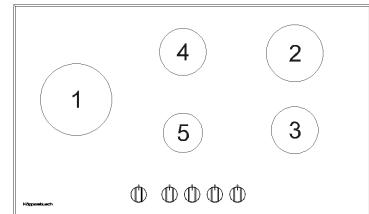
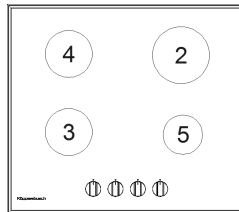
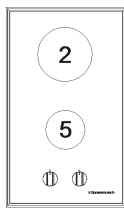

TABLE

BURNERS		GAS	NORMAL PRESSURE inches water column	INJECTOR DIAMETER 1/100 mm	NOMINAL HEAT INPUT (Btu/h)	
N°	DESCRIPTION				Min.	Max.
1	DUAL	PROPANE HD - 5 NATURAL GAS	11 7	66 125	7800 7800	13000 14500
	SIMMER	PROPANE HD - 5 NATURAL GAS	11 7	46 H2 90	1450 2100	2550 3200
2	RAPID	PROPANE HD - 5 NATURAL GAS	11 7	83 145	2400 2400	8350 8350
3	SEMIRAPID	PROPANE HD - 5 NATURAL GAS	11 7	58 100	2050 1700	4350 4350
4	SEMIRAPID	PROPANE HD - 5 NATURAL GAS	11 7	58 100	2050 1700	4350 4350
5	AUXILIARY	PROPANE HD - 5	11	50	1200	3400
		NATURAL GAS	7	90	1400	3400

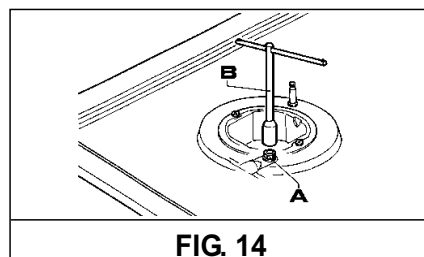

SERVICING

Always disconnect the appliance from the electricity and gas mains before proceeding with any servicing operation.

12) REPLACING COMPONENTS

Replacement of the components housed inside the appliance: remove the trivets and the burners from the upper part of the working table; remove the fixing screws "V" of the burner (fig. 15) and the knobs fixed by pressure with the hans, in order to take off the appliance.

After having carried out the above listed operations, the burners (fig. 16), taps (fig. 17) and electrical components can all be replaced (fig. 18).

NB: the ignition bar must be removed before replacing the taps in appliances with automatic ignition systems.

It is advisable to change seal "D" whenever a tap is replaced to ensure a perfect tightness.

Greasing the taps (see fig. 19)

If a tap becomes stiff to operate, it must be immediately greased in compliance with the following instructions:

- remove the tap.
- Clean the cone and its housing using a cloth soaked in diluent.
- Lightly spread the cone with the relative grease.
- Fit the cone back in place, operate it several times and then remove it again. Eliminate any excess grease and check that the gas ducts have not become clogged.
- Fit all parts back in place, complying with the demounting order in reverse.
- The tight closure test must be done using a foamy liquid. **The use of the flame is prohibited.**

To facilitate the servicing technician's task, here is a chart with the types and sections of the powering cables and the ratings of the electrical components.

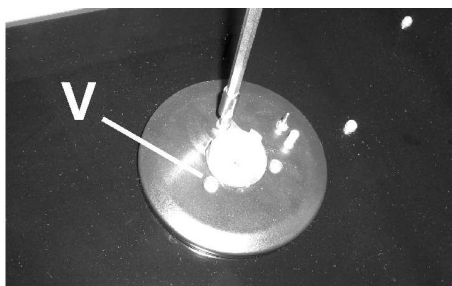

FIG. 15

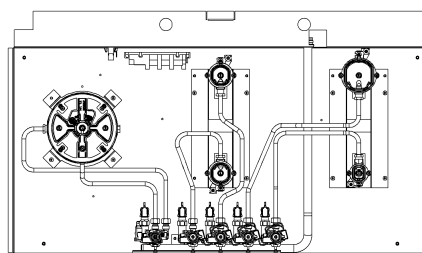

FIG. 16

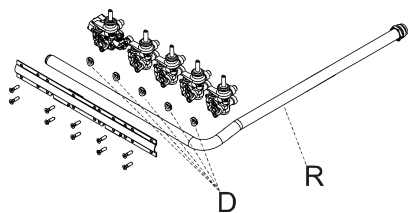

FIG. 17



FIG. 18

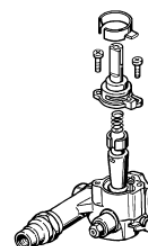

FIG. 19

TECHNICAL DATA ON THE DATA LABEL

2 BURNERS (30)

PROPANE HD - 5 = 11 inches water column
NATURAL GAS = 7 inches water column

ΣQ_n Natural Gas = 11750 Btu/h
 ΣQ_n Propane HD - 5 = 11750 Btu/h

Voltage = 120 V AC
Frequency = 60 Hz

4 BURNERS (60)

PROPANE HD - 5 = 11 inches water column
NATURAL GAS = 7 inches water column

ΣQ_n Natural Gas = 20450 Btu/h
 ΣQ_n Propane HD - 5 = 20450 Btu/h

Voltage = 120 V AC
Frequency = 60 Hz

5 BURNERS (90)

PROPANE HD - 5 = 11 inches water column
NATURAL GAS = 7 inches water column

ΣQ_n Natural Gas = 34950 Btu/h
 ΣQ_n Propane HD - 5 = 33450 Btu/h

Voltage = 120 V AC
Frequency = 60 Hz

TECHNICAL ASSISTANCE AND SPARES

Before leaving the factory, this appliance was tested and regulated by specially qualified experts in order to guarantee the best operating results.

The original spare parts can be found only in our Technical Assistance Centres and authorised shops.

Every repair or regulation operation which should become subsequently necessary must be carried out with the utmost care and attention by qualified personnel.

This is why we recommend that you always contact the Dealer who sold the appliance or our nearest Assistance Centre, specifying the brand, the model, the serial number and the type of problem affecting your appliance. The pertinent data is stamped on the label applied to the underside of the appliance and on the label applied to the packing box.

This information enables the technical assistance department to acquire the appropriate spare parts and consequently guarantee prompt and targeted intervention. We recommend that you write this data in the spaces below and keep it to hand at all times:

BRAND:

MODEL:

SERIES:

Küppersbusch USA
1883 Massaro Blvd. Tampa, FL 33619
Toll: (800) 459-0844 P: 813-288-8890 F: 813-288-8604



THE FUTURE OF COOKING SINCE 1875

Free Manuals Download Website

<http://myh66.com>

<http://usermanuals.us>

<http://www.somanuals.com>

<http://www.4manuals.cc>

<http://www.manual-lib.com>

<http://www.404manual.com>

<http://www.luxmanual.com>

<http://aubethermostatmanual.com>

Golf course search by state

<http://golfingnear.com>

Email search by domain

<http://emailbydomain.com>

Auto manuals search

<http://auto.somanuals.com>

TV manuals search

<http://tv.somanuals.com>