

# KUSTOM<sup>®</sup>

## OWNER'S MANUAL

### GROOVE 600™ BASS AMPLIFIER



Congratulations on the purchase of your new Kustom amplifier! Your new GROOVE 600™ offers unsurpassed sound quality and performance characteristics. Inside this manual you'll find detailed information regarding the amplifier's features. We wish you many years of enjoyment with your Kustom GROOVE 600™.

# ENGLISH

## Danger

Exposure to extremely high noise levels may cause a permanent hearing loss. Individuals vary considerably to noise induced hearing loss but nearly everyone will lose some hearing if exposed to sufficiently intense noise for a sufficient time.

The U.S. Government's Occupational Safety and Health Administration (OSHA) has specified the following permissible noise level exposures:

DURATION PER DAY (HOURS)	8	6	4	3	2	1
SOUND LEVEL (dB)	90	93	95	97	100	103

According to OSHA, any exposure in the above permissible limits could result in some hearing loss. Ear plugs or protectors in the ear canal or over the ears must be worn when operating this amplification system in order to prevent a permanent hearing loss. If exposure in excess of the limits as put forth above, to insure against potentially harmful exposure to high sound pressure levels, it is recommended that all persons exposed to equipment capable of inducing high sound pressure levels, such as this amplification system, be protected by hearing protectors while this unit is in operation.

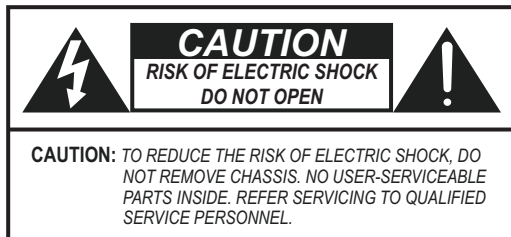

### AVIS: RISQUE DE CHOC ELECTRIQUE-NE PAS OUVRIR.



THIS SYMBOL IS INTENDED TO ALERT THE USER TO THE PRESENCE OF NON-INSULATED "DANGEROUS VOLTAGE" WITHIN THE PRODUCT'S ENCLOSURE THAT MAY BE OF SUFFICIENT MAGNITUDE TO CONSTITUTE A RISK OF ELECTRIC SHOCK TO PERSONS.



THIS SYMBOL IS INTENDED TO ALERT THE USER TO THE PRESENCE OF IMPORTANT OPERATING AND MAINTENANCE (SERVICING) INSTRUCTIONS IN THE LITERATURE ACCOMPANYING THE UNIT.



APPARATUS SHALL NOT BE EXPOSED TO DRIPPING OR SPLASHING AND THAT NO OBJECTS FILLED WITH LIQUIDS, SUCH AS VASES, SHALL BE PLACED ON THE APPARATUS.

## IMPORTANT SAFETY INSTRUCTIONS

1. Read all safety and operating instructions before using this product.
2. All safety and operating instructions should be kept for future reference.
3. Read and understand all warnings listed on the operating instructions.
4. Follow all operating instructions to operate this product.
5. This product should not be used near water, i.e. Bathtub, sink, swimming pool, wet basement, etc.
6. Only use dry cloth to clean this product.
7. Do not block any ventilation openings, It should not be placed flat against a wall or placed in a built-in enclosure that will impede the flow of cooling air.
8. Do not install this product near any heat sources ;such as, radiators, heat registers, stove or other apparatus (including heat producing amplifiers) that produce heat.
9. Do not defeat the safety purpose of the polarized or grounding-type plug. A polarized plug has two blades with one wider than the other. A grounding-type plug has two blades and a third grounding prong. The wide blade or the third prong are provided for your safety. If the provided plug does not fit into your outlet, consult an electrician for replacement of the obsolete outlet.
10. Protect the power cord being walked on or pinched, particularly at Plugs, convenience receptacles and the point where they exit from the apparatus. Do not break the ground pin of the power supply cord.
11. Only use attachments specified by the manufacturer.
12. Use only with the cart, stand, tripod, bracket, or table specified by the manufacturer or sold with the apparatus. When a cart is used, use caution when moving cart/ apparatus combination to avoid injury from tip-over. 
13. Unplug this apparatus during lightning storms or when unused for long periods of time.
14. Care should be taken so that objects do not fall and liquids are not spilled into the unit through the ventilation ports or any other openings.
15. Refer all servicing to qualified service personnel. Servicing is required when the apparatus has been damaged in any way; such as, power-supply cord or plug is damaged, liquid has been spilled or objects have fallen into the apparatus, the apparatus has been exposed to rain or moisture, does not operate normally or has been dropped.
16. WARNING: To reduce the risk of fire or electric shock, do not expose this apparatus to rain or moisture.
17. The MAINS plug or an appliance coupler is used as the disconnect device, the disconnect device shall remain readily operable.

# FRENCH

## Danger

L'exposition a des niveaux eleves de bruit peut provoquer une perte permanente de l'audition, Chaque organisme humain reagit differemment quant a la perte de l'audition, mais quasiment tout le monde subit une diminution de l'acuite auditive lors d'une exposition suffisamment longue au bruit intense. Les autorites competentes en reglementation de bruit ont defini les expositions tolerees aux niveaux de bruits:

DURE EN HEURES PAR JOUR	8	6	4	3	2	1
INIVEAU SONORE CONTINU EN dB	90	93	95	97	100	103

Selon les autorites, toute exposition dans les limites citees ci-dessus, peuvent provoquer certaines pertes d'audition. Des bouchons ou protections dans l'appareil auditif ou sur l'oreille doivent etre portes lors de l'utilisation de ce systeme d'amplification afin de prevenir le risque de perte permanente de l'audition, Dans le cas d'expositions superieures aux limites precitees il est recommande, afin de se premunir contre les expositions aux pressions acoustiques elevees potentiellement dangeereuses, aux personnes exposees aux equipements capables de delivrer de telles puissances, tels ce systeme d'amplification en fonctionnement, de proteger l'appareil auditif.



CE SYMBOLE A POUR BUT D'AVERTIR L'UTILISATEUR DE LA PRESENCE DE VOLTAGE DANGEREUX NON-ISOLE A L'INTERIEUR DE CE PRODUIT QUI PEUT ETRE DE PUISSANCE SUFFISAMMENT IMPORTANTE POUR PROVOQUER UN CHOC ELECTRIQUE AUX PERSONNES.



CE SYMBOLE A POUR BUT D'AVERTIR L'UTILISATEUR DE LA PRESENCE D'INSTRUCTIONS D'UTILISATION ET DE MAINTENANCE DANS LES DOCUMENTS FOURNIS AVEC CE PRODUIT.



AFIN DE REDUIRE LES RISQUÉ D'INCENDIE ET DE DECHARGE ELECTRIQUE, NE PAS EXPOSER CET APPAREIL A LA PLUIE OU A L'HUMIDITE.

## IMPORTANTES INSTRUCTIONS DE SECURITE

1. Lire avec attention toutes les recommandations et précautions d'emploi avant d'utiliser ce produit.
2. Toutes les recommandations et précautions d'emploi doivent être conservées afin de pouvoir s'y reporter si nécessaire.
3. Lire et comprendre tous les avertissements énumérés dans les précautions d'emploi.
4. Suivre toutes les précautions d'emploi pour utiliser ce produit.
5. Ce produit ne doit pas être utilisé près d'eau, comme par exemple baignoires, éviers, piscine, sous-sol humides ... Etc.
6. Utiliser exclusivement un chiffon sec pour nettoyer ce produit.
7. Ne bloquer aucune ouverture de ventilation. Ne pas placer le produit tout contre un mur ou dans une enceinte fermée, cela générerait le flux d'air nécessaire au refroidissement.
8. Ne pas placer le produit près de toute source de chaleur telle que radiateurs, arrivées d'air chaud, fourneaux ou autres appareils générant de la chaleur (incluant les amplificateurs producteurs de chaleur) .
9. Ne pas négliger la sécurité que procure un branchement polarisé ou avec raccordement à la terre, Un branchement polarisé comprend deux fiches dont l'une est plus large que l'autre. Un branchement à la terre comprend deux fiches plus une troisième reliée à la terre. Si la fiche secteur fournie ne s'insère pas dans votre prise de courant. consulter un 'électricien afin de remplacer votre prise obsolète.
10. Protéger le cordon d'alimentation de tout écrasement ou pincement, particulièrement au niveau des fiches, des réceptacles utilisés et à l'endroit de sortie de l'appareil. Ne pas casser la fiche de terre du cordon d'alimentation.
11. Utiliser uniquement les accessoires spécifiés par le constructeur.
12. Utiliser uniquement avec le chariot de transport, le support, le trépied, la console ou la table spécifiés par le constructeur ou vendus avec l'appareil. Lors de l'utilisation d'un chariot, bouger avec précaution l'ensemble chariot/appareil afin d'éviter les dommages d'un renversement.
13. Débrancher cet appareil lors d'orages ou s'il n'est pas utilisé pendant une longue période.
14. Des précautions doivent être prises afin qu'aucun objet ne tombe et qu'aucun liquide ne se répande à l'intérieur de l'appareil par les orifices de ventilation ou n'importe quelle autre ouverture.
15. Pour toutes interventions techniques s'adresser à un technicien qualifié. L'intervention technique est nécessaire lorsque l'appareil a été endommagé de n'importe quelle façon, comme par exemple si le cordon secteur ou sa fiche sont détériorés, si du liquide a coulé ou si des objets sont tombés à l'intérieur de l'appareil, si l'appareil a été exposé à la pluie ou à l'humidité, s'il ne fonctionne pas normalement ou s'il est tombé.
16. ATTENTION: Pour réduire le risque d'incendie ou de choc électrique ne pas exposer l'appareil à la pluie ou à l'humidité.
17. La prise Mains, au coupler, est utilisée pour la source d'alimentation électrique. Il est conseillé de garder cette prise facilement accessible.



# Product Contents

These items are included with your GROOVE 600™ amplifier.  
Be sure to contact your dealer if any items are missing.

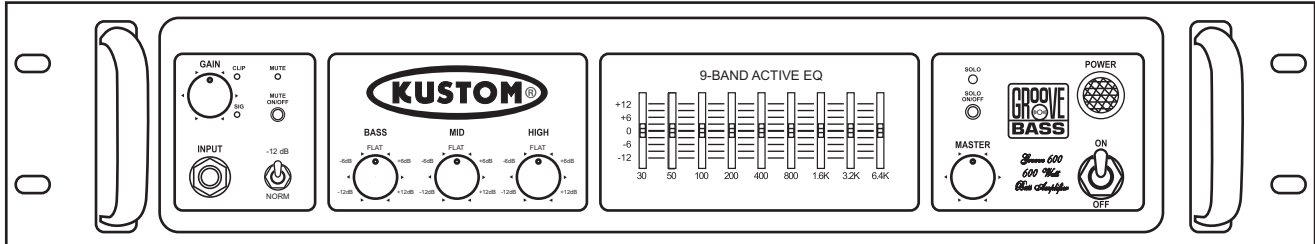

**GROOVE 600™ Amplifier**

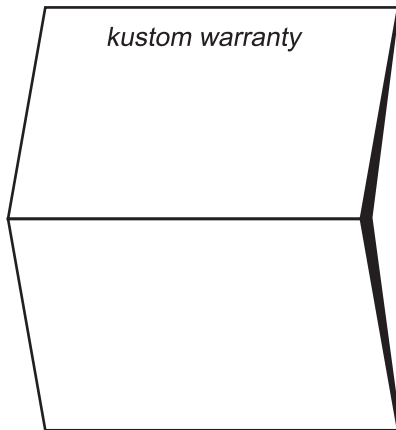

**Warranty Card**

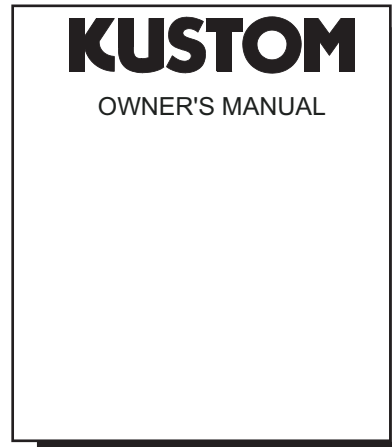

**Owners Manual**

# Quick Setup

After reviewing this Quick Setup page, feel free to experiment with the controls and create your own unique sound.

- ① Set tone controls flat and **Master Volume Control** down.

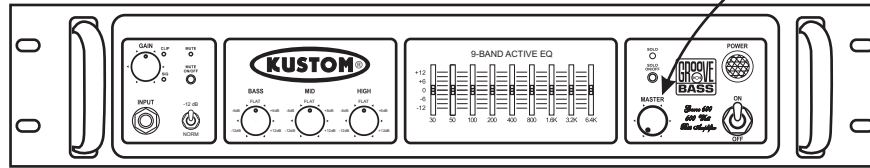

- ② Connect input, AC power cord, footswitch cable, and speaker cable. If using an active bass, toggle the **NORM/-12 dB Switch** to -12 dB. If the Red **Clip Indicator** lights while playing, toggle the **NORM/-12 dB Switch** to -12 dB.

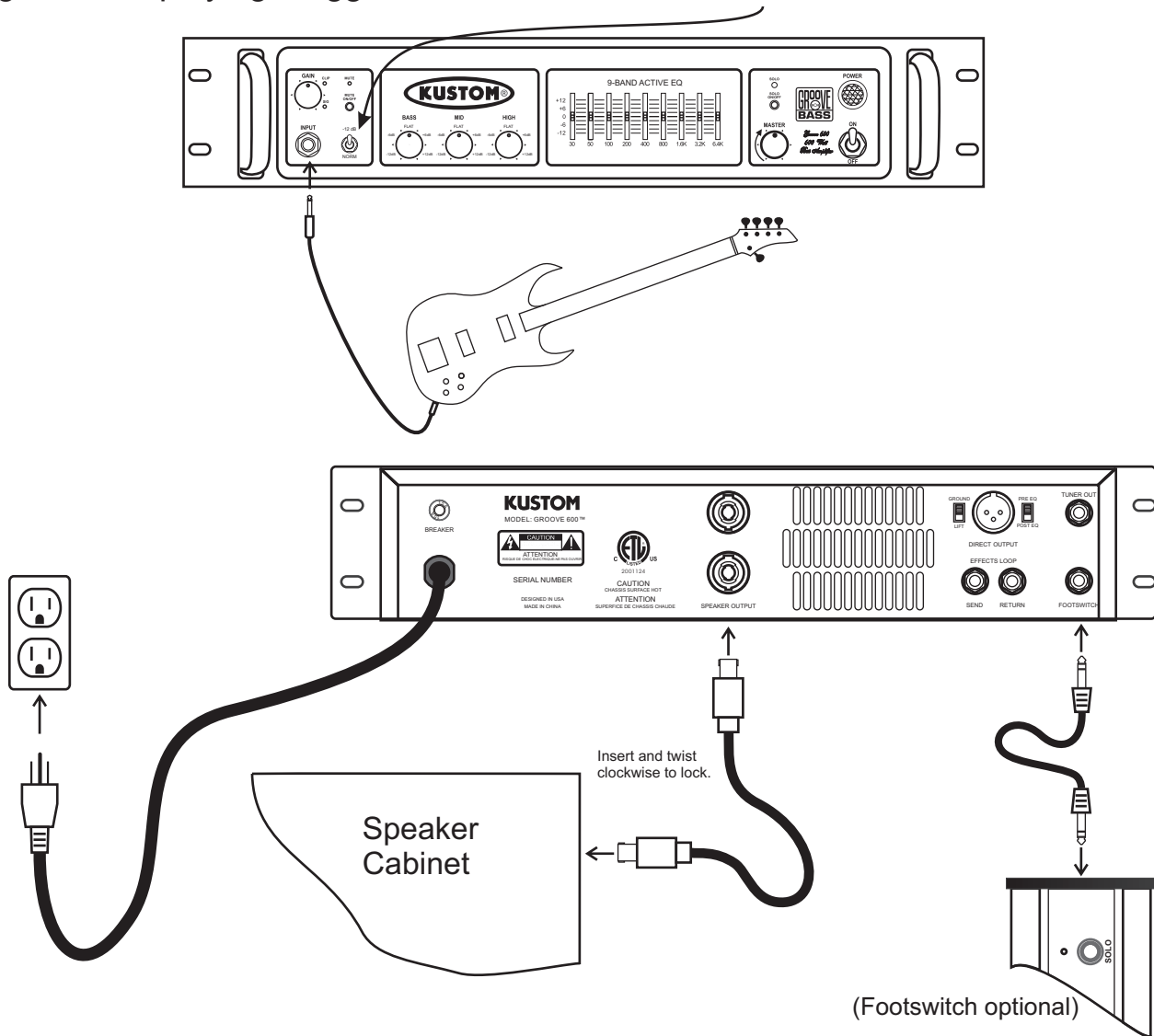

- ③ Turn on the **Power Switch**. Play an open string and adjust the **Gain Control** until the Green **Signal Indicator** lights regularly. Turn up **Master Volume Control** slowly to desired level, and start playing.

# Front Panel

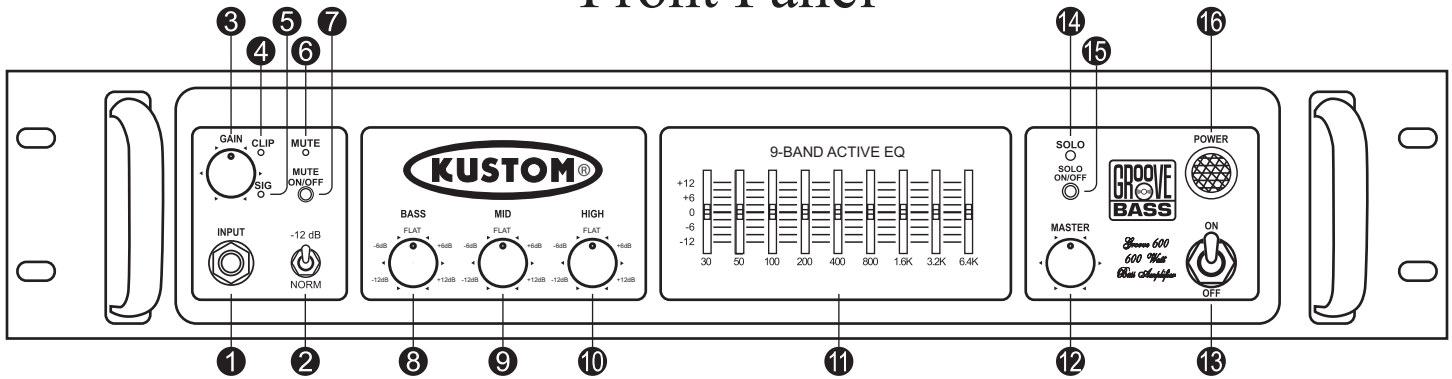

- 1 Input Jack:**  
This is a 1/4" 2-conductor input jack for plugging in your instrument using a shielded instrument cable. It is intended for bass guitar but will accept other instruments and line level signals as well.
- 2 NORM/-12 dB Switch**  
Set this switch to -12 dB when using an active bass guitar or line level signal. Setting to -12 dB will lower the input gain by 12 dB.
- 3 Gain Control:**  
Controls the amount of input to the preamp. Adjust so **SIG** indicator illuminates when notes are played.
- 4 Clip Indicator:**  
Indicates when the input signal has reached maximum level. If indicator illuminates when notes are played, set **NORM/-12 dB** switch to -12 dB and/or turn down **GAIN** control.
- 5 Signal Indicator:**  
Indicates when sufficient signal is applied to the preamp. Adjust **GAIN** control so indicator illuminates when notes are played.
- 6 Mute Indicator:**  
This red LED will blink indicating all outputs are muted except for the **TUNER OUT** (rear panel #23). Muting can be done by either depressing the **MUTE ON/OFF** switch on the front panel or by pressing **MUTE** on the footswitch.
- 7 Mute On/Off Switch:**  
When this switch is depressed, all outputs are muted except for the **TUNER OUT** (rear panel #23). **Note:** Using footswitch overrides this switch.
- 8 Bass Control:**  
Controls the amount of low frequency in the signal. This control is centered at 65 Hz.
- 9 Mid Control:**  
Controls the amount of midrange frequency in the signal. This control is centered at 500 Hz.
- 10 High Control:**  
Controls the amount of high frequency in the signal. This control is centered at 3 kHz.
- 11 Graphic Equalizer Section:**  
This 9-band graphic equalizer is used to adjust the sound to the room acoustics. It may also be used to finely adjust sound to taste.
- 12 Master Volume Control:**  
Controls the overall output of the amplifier. Use in conjunction with the **GAIN** control to obtain desired speaker output.
- 13 Power Switch:**  
Turns AC power on and off. **Note:** When power is first applied, there is a slight delay before sound is heard through the speakers.
- 14 Solo Indicator:**  
This blue LED is lit when the **SOLO** mode has been activated.
- 15 Solo On/Off Switch:** This switch when depressed, activates **SOLO** mode. When active, the signal to the power amp will be boosted by 6dB.
- 16 Power Jewel:**  
Indicates when AC power is applied to the amplifier.



# Rear Panel

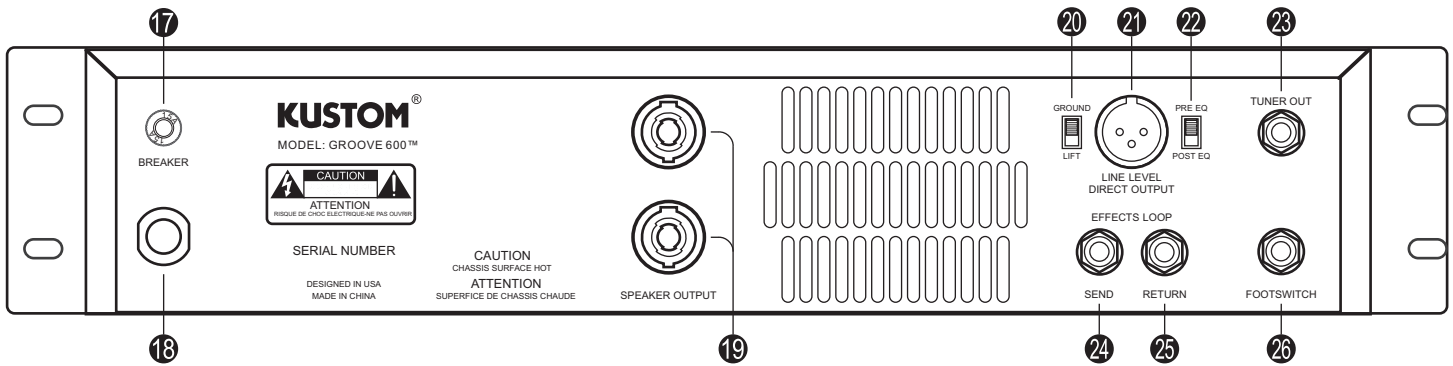

## 17 Circuit Breaker:

This circuit breaker will trip when too much current is applied to the amplifier. To reset: Turn off **POWER** switch, allow to cool for a few minutes, then press circuit breaker button, and turn the **POWER** switch on. Note: If the Circuit Breaker trips repeatedly when AC power is applied, take the amplifier to an authorized service center for repair.

## 18 Power Cord:

This supplies AC power to the amplifier. If the cord becomes damaged, take the amplifier to an authorized service center for repair.

## 19 Speaker Outputs:

Use these jacks to connect the amplifier to speaker cabinets using heavy duty Speakon® speaker cables. These jacks are connected together internally. See **Amplifier Loading Chart** (Page 8) for speaker cabinet loading information. **Note:** To prevent overheating and possible loss of signal, do not connect a load lower than 2 ohms. Be sure power is off before making any speaker connections. To connect a cable: Align tab on speaker cable connector slot. Insert and twist one quarter turn clockwise to lock. To remove a cable: Pull back release button on cable connector, twist connector counter clockwise one quarter turn, and pull out connector.

## 20 Ground Lift Switch:

Activating this switch removes the ground connection on the **DIRECT OUTPUT** Jack (#21). Activate this switch, if necessary to eliminate hum.

## 21 Direct Output Jack:

This is a line level output used to connect the amplifier to another device, such as a mixer or recorder.

## 22 Pre EQ/Post EQ Switch:

When set to Pre EQ, the **DIRECT OUTPUT** signal will be unaltered by the EQ sections of the preamp. When set to Post EQ, the **DIRECT OUTPUT** signal will reflect the entire sound (including EQ settings) of the preamp. **Note:** The **MASTER** volume Control (front panel #12) and **SOLO ON/OFF** switch (front panel #15) have no effect on the **DIRECT OUTPUT** signal.

## 23 Tuner Out Jack:

Use this jack to connect to a tuner or other line level device. This jack is always active and is a pre-gain output.

## 24 Effects Send Jack:

Use this jack to connect to the input of an external effects processor. This jack can also be used as a preamp out.

## 25 Effects Return Jack:

Use this jack to connect to the output of an external effects processor. This jack can also be used as a power amp in. The preamp output signal is disconnected from the power amp when using this jack.

## 26 Footswitch Jack:

This 3-conductor 1/4" jack is for connecting a footswitch (sold separately) to the amplifier. The footswitch will then control the Mute and Solo features. Using this jack overrides the front panel **MUTE** and **SOLO** switches.

# Speaker Connection Diagram

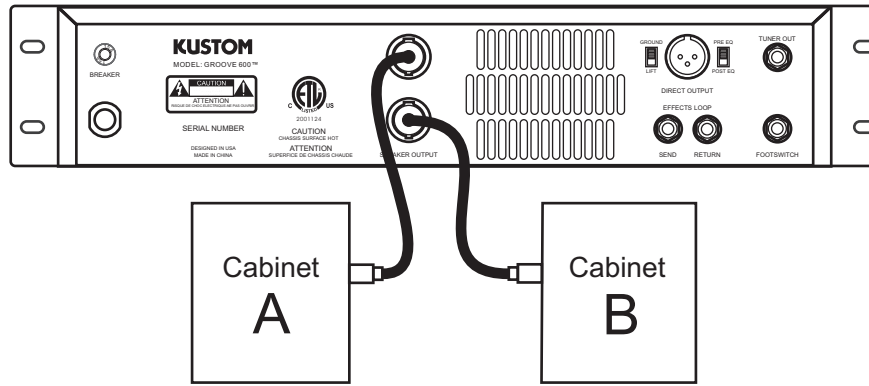

## Amplifier Loading Chart

Speaker cabinet loads (ohms) applied to the amplifier		Cabinet A's Impedance (ohms)								
		open	16	8	5.33	4	3.20	2.67	2	
Cabinet B's Impedance	open	open	16	8	5.33	4	3.2	2.67	2	
	16	16	8.00	5.33	4.00	3.20	2.67	2.29	1.78	
	8	8	5.33	4.00	3.20	2.67	2.29	2.00	1.60	
	5.33	5.33	4.00	3.20	2.67	2.29	2.00	1.78	1.45	
	4	4	3.20	2.67	2.29	2.00	1.78	1.60	1.33	
	3.20	3.2	2.67	2.29	2.00	1.78	1.60	1.46	1.23	
	2.67	2.67	2.29	2.00	1.78	1.60	1.46	1.34	1.14	
2	2	1.78	1.60	1.45	1.33	1.23	1.14	1.00		
		<b>Total load on amplifier</b> Note: To prevent overheating and possible loss of signal, do not use any combination of cabinets that results in a box that is shaded.								

This chart can help you determine what load (ohms) is present on the amplifier when using multiple cabinets.

- To use this chart with two cabinets (A and B), find cabinet A's impedance (ohms) column and cabinet B's impedance row on the chart. The total load on the amplifier is shown in the box where they meet. For example: If cabinet A's impedance is 8 ohms and cabinet B's impedance is 4 ohms, the total load on the amplifier would be 2.67 ohms.

- To use this chart with three or more cabinets, find the total load for two cabinets and then use the result for cabinet A's impedance column. The third cabinet will then be used for cabinet B's impedance row on the chart. Find the total load on the amplifier and repeat if more cabinets are used. For example (using 3 cabinets): If the first cabinet (cabinet A) has an impedance of 16 ohms and the second (cabinet B) has an impedance of 8 ohms, the total load would be 5.33 ohms. Using this load (5.33) as cabinet A's impedance and a third cabinet's (new cabinet B) impedance of 4 ohms, you would find that the total load on the amplifier is 2.29 ohms. **Note:** It is not recommended to use any combination of cabinets that has a resulting load in a shaded area of the chart.

## Alternate Connection Diagrams

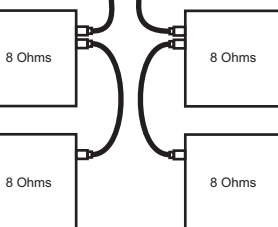

Total Load On Amplifier = 2 Ohms

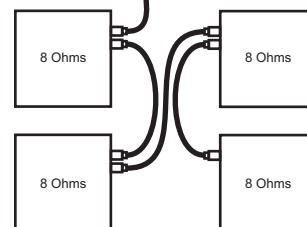

Total Load On Amplifier = 2 Ohms

Note: Some efficiency is reduced due to line loss using this method



# GROOVE 600™ Specifications

<b>Model</b>	Groove 600HD	Bass guitar amplifier
<b>Input Impedance</b>	200K Ohm	
<b>Output Power</b>	275 Watts	8 Ohms @ 1% THD
	450 Watts	4 Ohms @ 1% THD
	600 Watts	2 Ohms @ 1% THD
<b>Frequency Response</b>	20HZ-20kHz	Actual response is tailored to speakers for accurate acoustical response using a bass guitar as input.
<b>Hum &amp; Noise</b>	-60dB	Residual Noise, all level controls 0% (minimum)
<b>System Gain</b>	27dB	Preamp output
	15dB	Preamp output, Gain switch set to -12dB
	25dB	Tuner output
	27dB	Direct output
	29dB	Power amp gain
All measurements taken with 1 KHz input signal, Tone controls flat, Gain and Volume Maximum. Measured at effects send output jacks on rear unless noted.		
<b>Amplifier Type</b>	Class B	Discrete device Class B amplifier
<b>Footswitch</b>	KAC-GFS100 recommended, but any non-momentary two-button foot switch can be used. Use any standard tip-ring-sleeve 1/4" cable	
<b>Power Requirements</b>	USA/Canada	120VAC/60Hz, 800W nominal
	Europe	230VAC/50Hz, 800W nominal
	UK	230VAC/50Hz, 800W nominal
	Australia	240VAC/50Hz, 800W nominal
	Japan	100VAC/50-60Hz, 800W nominal
<b>Dimensions</b>	mm/kg	89 (Height) x 483 (Width) x 390 (Depth), 12 kg
	Inches/Pounds	3.5 (Height) x 19 (Width) x 15.5 (Depth), 26 lbs

## Rack Mounting Instructions

The GROOVE 600™ was designed to mount into a standard 2-space rack. When mounting, use 4 screws to secure the amplifier to the rack. When using only one amplifier, use the bottom 2 spaces in the rack. However, if more than one amplifier is used, leave one space open between the amplifiers to ensure proper ventilation (shown below).

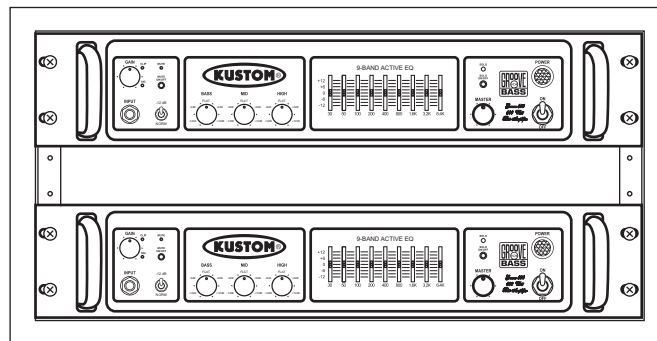

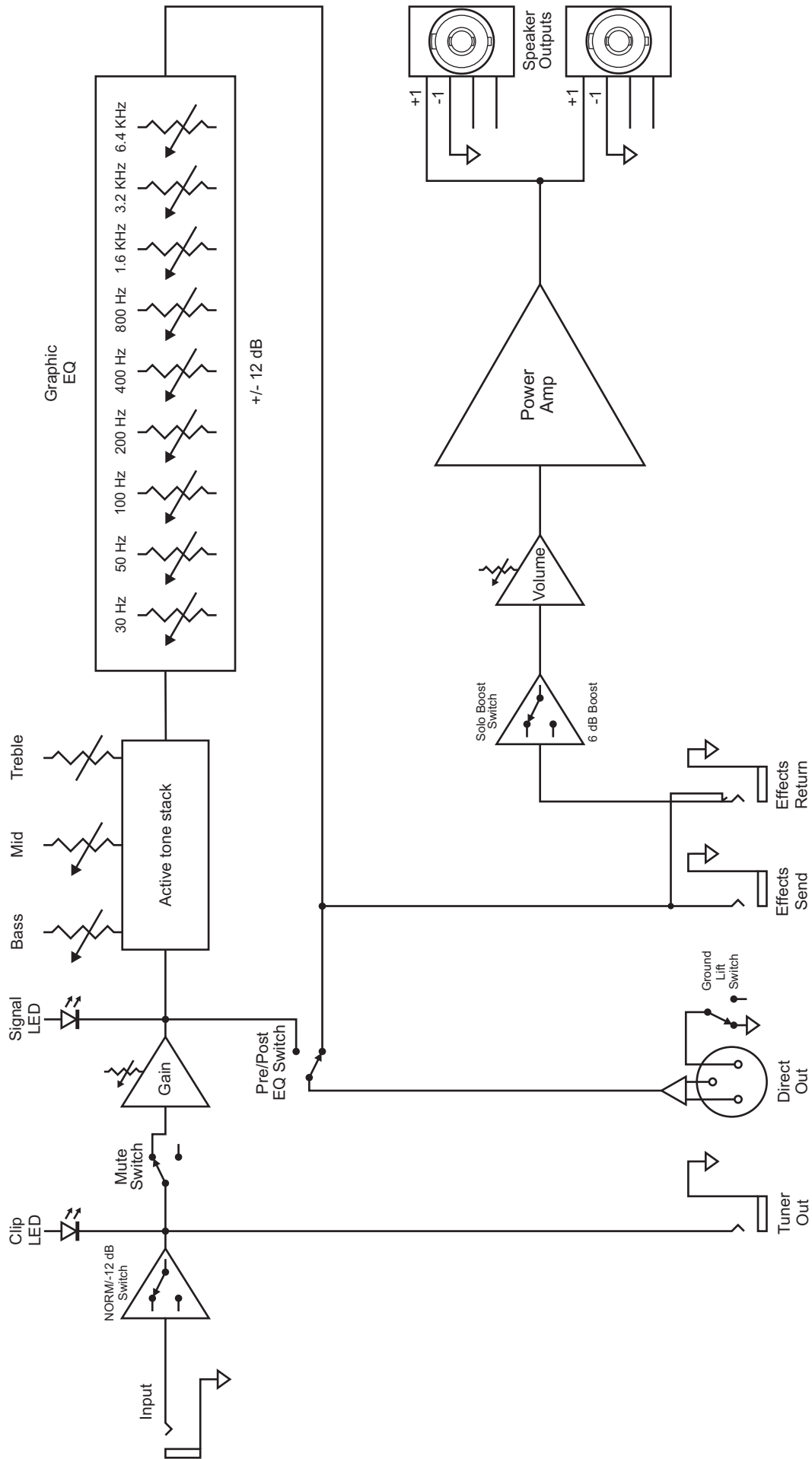

# GROOVE 600™ Signal Flow Diagram

# EC Declaration of Conformity

We: Kustom Musical Amplification Inc.  
PO. Box 568  
Hebron, Ky 41048-0568  
Tel: 1-859-817-7100 Fax: 1-859-817-7150

Declare that the product

Product name: Kustom

Product model number: GROOVE 600HD

to which this declaration relates is in conformity with the following standards;

EN55013 (A12) : 1995	Limits and methods of measurement of radio disturbance characteristics of broadcast receivers and associated equipment.
EN55020: 1995	Electromagnetic immunity of broadcast receivers and associated equipment.
EN61000-3-2: 1995	Limits for harmonic current emissions (equipment input current $\leq$ 16A per phase).
EN61000-3-3: 1995	Limitation of voltage fluctuations and flicker in low voltage supply systems for equipment with rated currents $\leq$ 16A.
EN55103-1: 1995	Electromagnetic Compatibility - Product family standard for Audio, Video Audio-visual and entertainment Lighting Control Apparatus.
EN60065: 1994	Safety requirements for main operated electronic and related apparatus for household and similar general use.

Following the provisions of EU Council Directive(s): 72/73 EEC and 89/336/EEC.

We the undersigned, hereby declare that the equipment specified above conforms to the aforementioned directive(s).

Name of authorized person: James Brown, VP Engineering

Signature:  Date: 15 DECEMBER 2006

Kustom Amplification Inc.  
PO. Box 568  
Hebron, Ky 41048-0568  
Tel: 1-859-817-7100 Fax: 1-859-817-7150

**KUSTOM**<sup>®</sup> Kustom Amplification Inc., PO BOX 568, Hebron, KY • USA  
888-4-KUSTOM (888-458-7866) Web: [www.kustom.com](http://www.kustom.com)



## Free Manuals Download Website

<http://myh66.com>

<http://usermanuals.us>

<http://www.somanuals.com>

<http://www.4manuals.cc>

<http://www.manual-lib.com>

<http://www.404manual.com>

<http://www.luxmanual.com>

<http://aubethermostatmanual.com>

Golf course search by state

<http://golfingnear.com>

Email search by domain

<http://emailbydomain.com>

Auto manuals search

<http://auto.somanuals.com>

TV manuals search

<http://tv.somanuals.com>