

# Operator's Manual

RC35120 RCM35120

Rotary Cutter

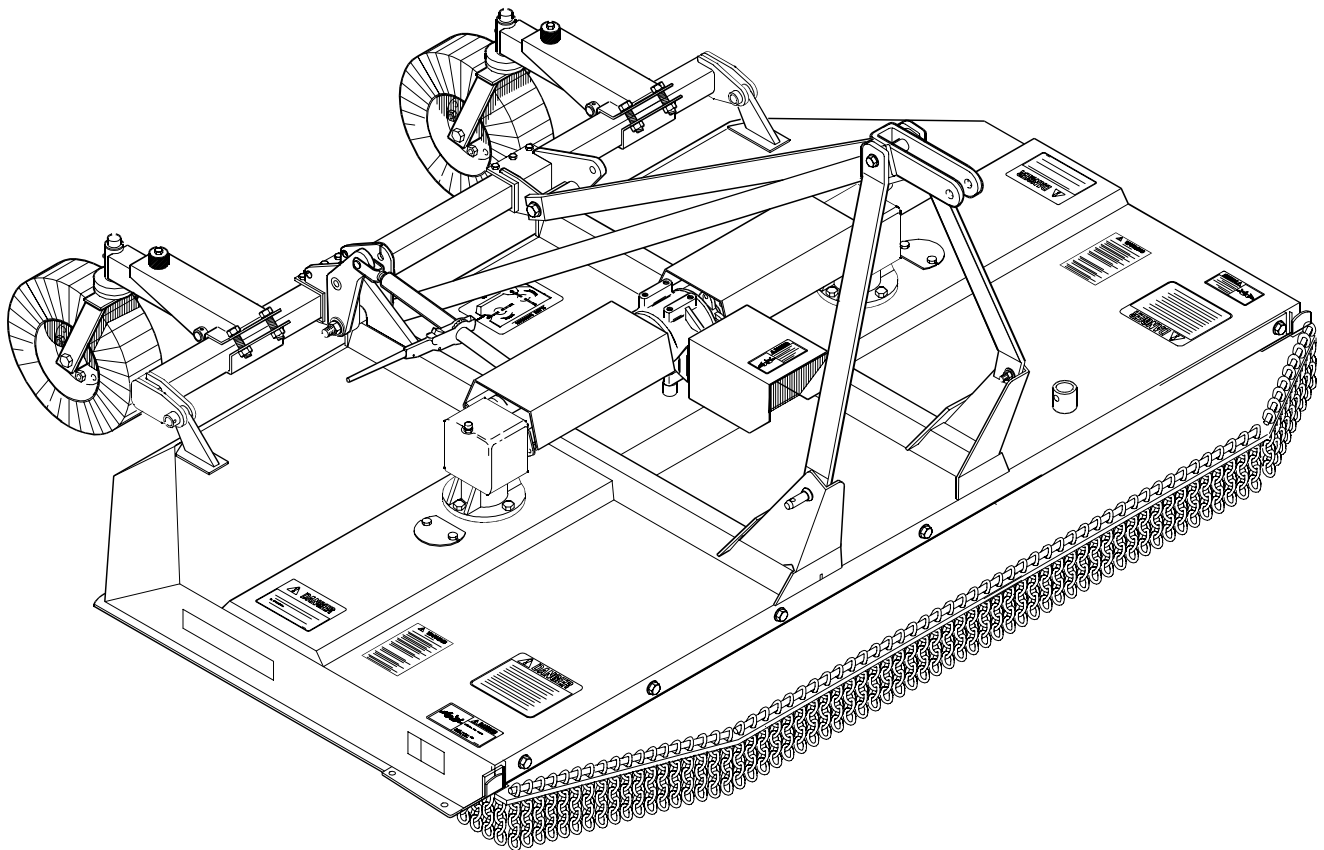

10438

*Cover photo may show optional equipment not supplied with standard unit.*



Read the Operator's manual entirely. When you see this symbol, the subsequent instructions and warnings are serious - follow without exception. Your life and the lives of others depend on it!

© Copyright 2000 Printed 11/16/00



312-301M

## Table of Contents

# Table of Contents

<b>Important Safety Information</b> . . . . .	<b>1</b>	<b>Section 3 Adjustments</b> . . . . .	<b>16</b>
Safety Notations . . . . .	1	Lift-Type Cutting Height . . . . .	16
Safety Rules . . . . .	1	Pull-Type Cutting Height . . . . .	16
Safety Labels . . . . .	2	Deck Attitude Adjustment . . . . .	16
<b>Introduction</b> . . . . .	<b>6</b>	<b>Section 4 Troubleshooting</b> . . . . .	<b>17</b>
Using This Manual . . . . .	6	<b>Section 5 Maintenance and Lubrication</b> . . . . .	<b>19</b>
Terminology: . . . . .	6	Maintenance . . . . .	19
Definitions: . . . . .	6	Service Cutting Blades . . . . .	19
Owner Assistance . . . . .	6	Skid Shoe Service & Replacement . . . . .	19
<b>Section 1 Assembly and Setup</b> . . . . .	<b>7</b>	Flex Couplers . . . . .	20
Tractor Requirements . . . . .	7	Clutch Run-In . . . . .	20
Lift-Type Cutter . . . . .	7	Storage . . . . .	20
Hitch & Axle Assembly . . . . .	7	Lubrication . . . . .	20
Tailwheel . . . . .	8	Pivoting Upper Hitch . . . . .	20
Pull-Type Cutter . . . . .	9	Lift-Type Tailwheel Spindle Hub . . . . .	20
Tongue . . . . .	9	Lift-Type Tailwheel Hub . . . . .	21
Rear Axle . . . . .	10	Pull-Type Tailwheel Hub . . . . .	21
Leveling Rod . . . . .	10	Ratchet Jack . . . . .	21
Driveline Installation . . . . .	11	Driveline U-Joints . . . . .	21
Lift-Type Cutter . . . . .	11	Driveline . . . . .	22
Pull-Type Cutter . . . . .	11	Gearbox . . . . .	22
Safety Guards . . . . .	11	T-Box . . . . .	22
Tractor Hook-Up . . . . .	11	4-Plate Slip Clutch . . . . .	23
Lift-Type Cutter . . . . .	11	Disassembly . . . . .	23
Pull-Type Cutter . . . . .	13	Assembly . . . . .	23
<b>Section 2 Operating Instructions</b> . . . . .	<b>14</b>	<b>Section 6 Specifications and Capacities</b> . . . . .	<b>24</b>
Transporting . . . . .	14	<b>Section 7 Appendix</b> . . . . .	<b>25</b>
Operating Check List . . . . .	14	Torque Values Chart for Common Bolt Sizes . . . . .	25
Cutting Instructions . . . . .	14		

© Copyright 2000 All rights Reserved

Land Pride provides this publication "as is" without warranty of any kind, either expressed or implied. While every precaution has been taken in the preparation of this manual, Land Pride assumes no responsibility for errors or omissions. Neither is any liability assumed for damages resulting from the use of the information contained herein. Land Pride reserves the right to revise and improve its products as it sees fit. This publication describes the state of this product at the time of its publication, and may not reflect the product in the future. The illustrations in this manual are not intended for safe and proper assembly or disassembly of equipment. The illustrations are intended for ordering parts only.

Land Pride is registered trademark.

All other brands and product names are trademarks or registered trademarks of their respective holders.

Printed in the United States of America.

# Important Safety Information

For your safety and to develop a better understanding of your equipment, thoroughly read the Operator's Sections of this manual before operation.

## Safety Notations

The SAFETY ALERT SYMBOL indicates that there is a potential hazard to personal safety involved and extra safety precautions must be taken. When you see this symbol, be alert and carefully read the message that follows it. In addition to design and configuration of equipment; hazard control and accident prevention are dependent upon the awareness, concern, prudence and proper training of personnel involved in the operation, transport, maintenance and storage of equipment.

**Watch for the following Safety Notations throughout your Operator's Manual:**



### **DANGER!**

Indicates an imminently hazardous situation which, if not avoided, **will** result in death or serious injury. This signal word is limited to the most extreme situations.



### **WARNING!**

Indicates a potentially hazardous situation which, if not avoided, **could** result in death or serious injury.



### **CAUTION!**

Indicates a potentially hazardous situation which, if not avoided, **may** result in minor or moderate injury. It may also be used to alert against unsafe practices

## Safety Rules

**These rules and instructions must be reviewed at least annually by all operators!**

Most accidents are the result of negligence and carelessness, caused by failure of the operator to follow safety precautions. Even though your implement is designed with many built-in safety features, the following precautions are mandatory to prevent such accidents.

Make sure everyone that uses this machine has read the Operator's Manual and understands how to operate it safely.

This Operator's Manual is considered a part of the implement and should remain so when loaned or sold.

### **Prior To Operation**

1. Do not allow anyone to operate this machine who has not been properly trained in its safe operation.
2. Wear proper eye protection to prevent injury from flying objects.
3. To prevent personal injury caused by thrown objects, the use of front safety shields is strongly recommended.
4. Do not let children operate the implement.
5. Never allow passengers.
6. Do not leave the tractor or the implement unattended with the engine running.
7. Before cutting, clear the area of objects and debris that could become entangled in the blades or thrown from the cutter.

### **During Operation**

1. Never operate the cutter near people and do not stand near the cutter while blades are in motion.
2. After striking an object, disengage PTO, shut off tractor and inspect for damage before continuing.
3. Do not operate the cutter in reverse unless necessary. Debris may be thrown from the front of the cutter; therefore, increasing the risk of injury to the operator.
4. Check the cutter periodically for loose hardware and tighten if necessary.
5. Never operate the cutter while in the raised transport position.
6. Disengage the PTO when raised for transport or backing up.
7. Travel slowly over rough terrain and be alert to holes and gullies.
8. Use warning flags or approved warning lights at night and during other periods of poor visibility. Do your best to prevent highway accidents.
9. Be alert to traffic when crossing or cutting near roadways. Always maintain complete control of the machine. Know your state and local laws concerning highway safety and regulations. Comply with these laws when transporting machinery.
10. Keep PTO shielding in place and in good condition. Do not operate cutter with shields missing.
11. Always use proper PTO speed or machine damage may result.
12. In order to maintain steering control, add ballast to tractor. To determine the amount of ballast required refer to your tractor operator's manual.

### **During Maintenance**

1. Before performing maintenance, disconnect PTO driveline and securely block cutter on safe supporting stands. Do not position stands under axle or wheel supports.

## Important Safety Information

### Safety Labels

Your implement comes equipped with all safety labels in place. They were designed to help you safely operate your implement.

2. Read and follow label directions.
3. Keep all safety labels clean and legible.
4. Replace all damaged or missing labels.
5. Some new equipment installed during repair require safety labels to be affixed to the replaced component as specified

- by the manufacturer. When ordering new components make sure the correct safety labels are included in the request. To order new labels go to your Land Pride dealer.
6. Refer to this section for proper label placement. To install new labels:
    - a. Clean the area the label is to be placed.
    - b. Peel backing from label. Press firmly on surface being careful not to cause air bubbles under label.

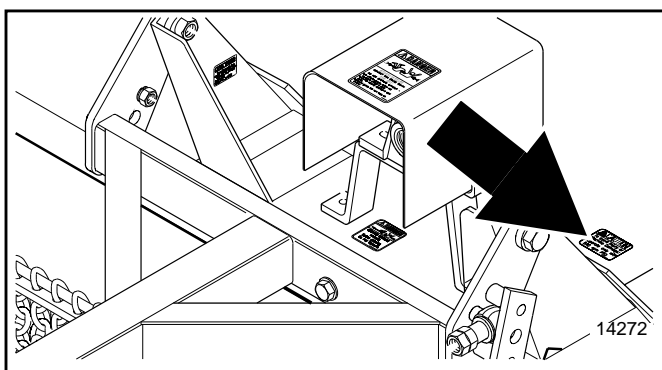

**818-130C**  
Caution 540 RPM

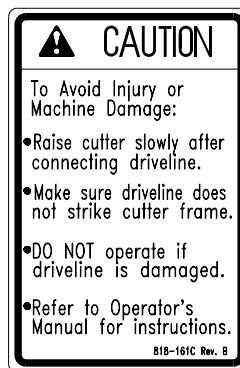
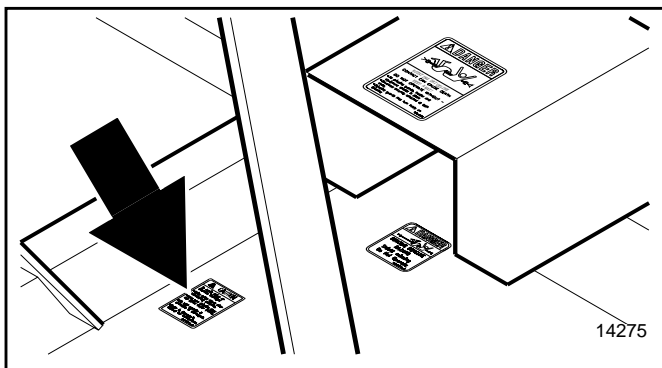

**818-161C**  
Caution Rotary Cutter  
General Safety

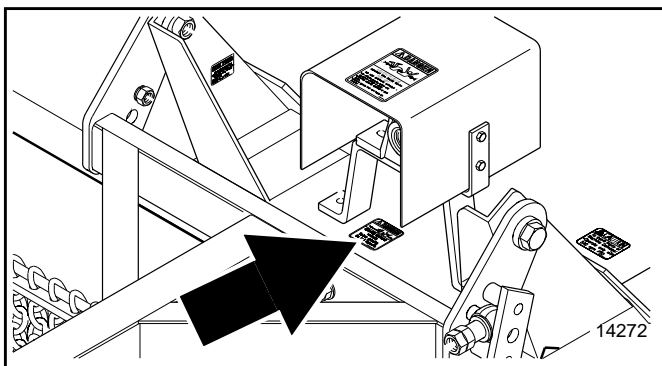

**818-187C**  
Danger PTO Shield

### Important Safety Information

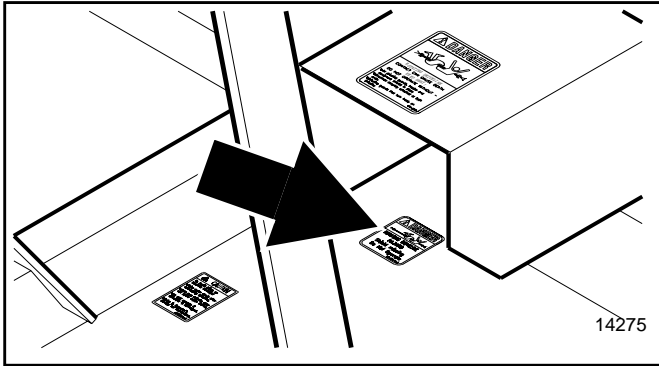

**818-187C**  
Danger PTO Shield

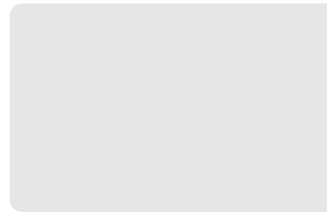
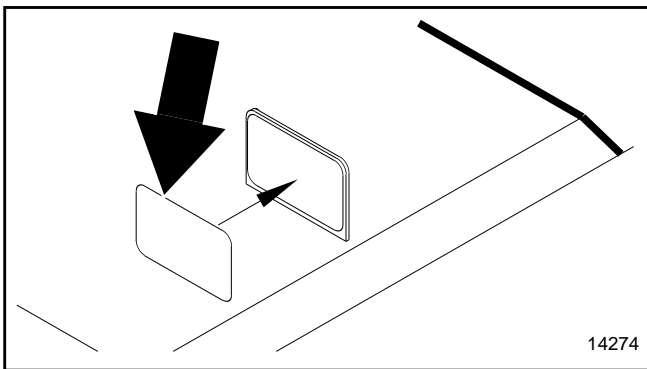

**818-229C**  
Amber Reflector

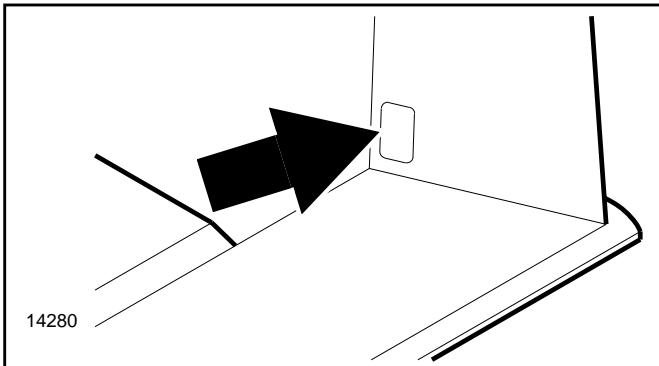

**818-230C**  
Red Reflector

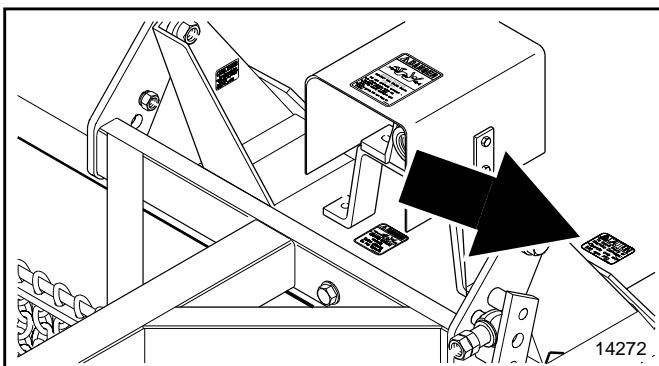

**818-240C**  
Caution 1000 RPM

**Important Safety Information**

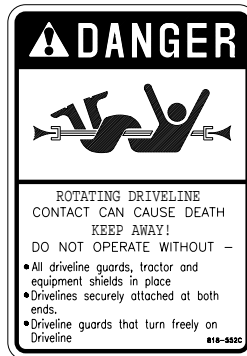
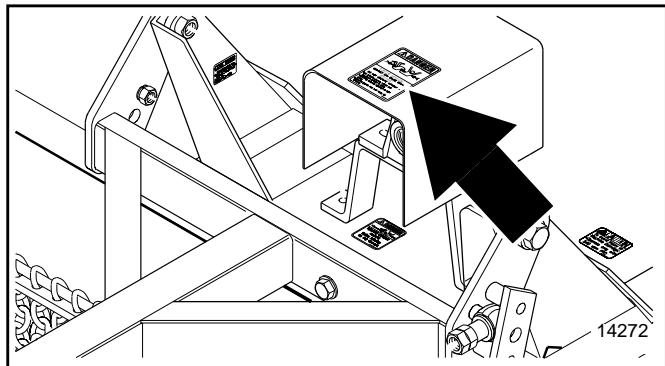

**818-552C**  
Danger PTO Driveline

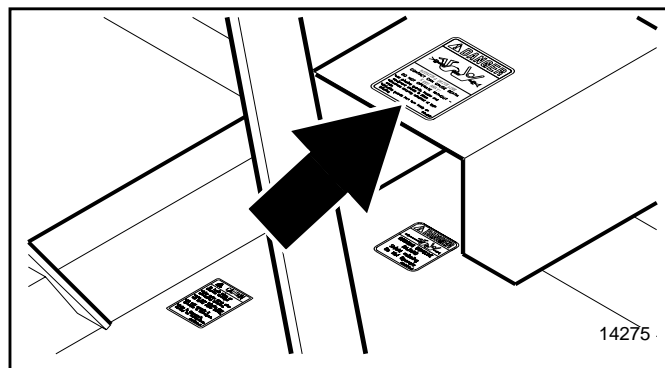

**818-552C**  
Danger PTO Driveline

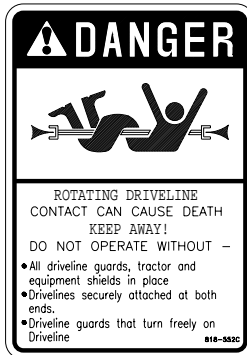
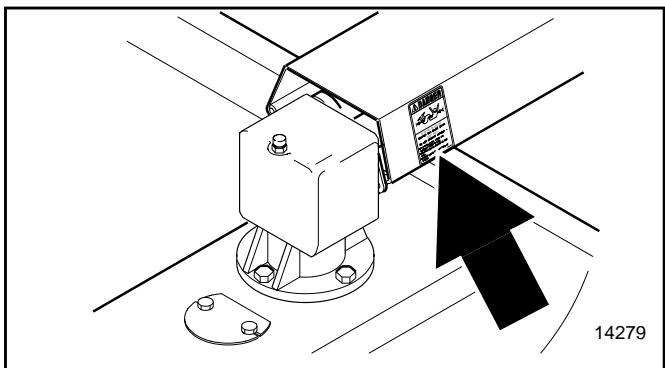

**818-552C**  
Danger PTO Driveline

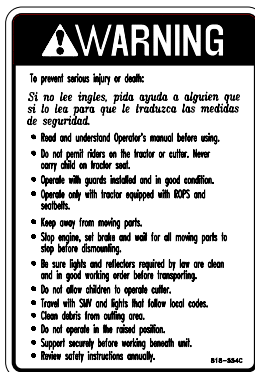
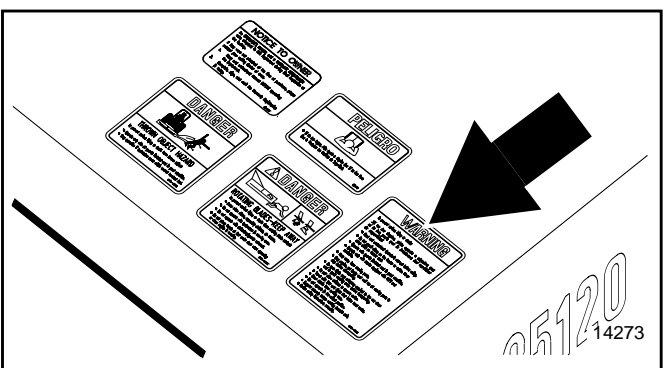

**818-554C**  
Warning General  
Cutter Safety

# Important Safety Information

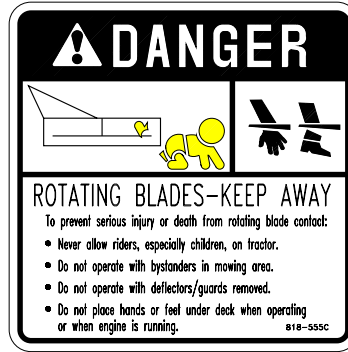
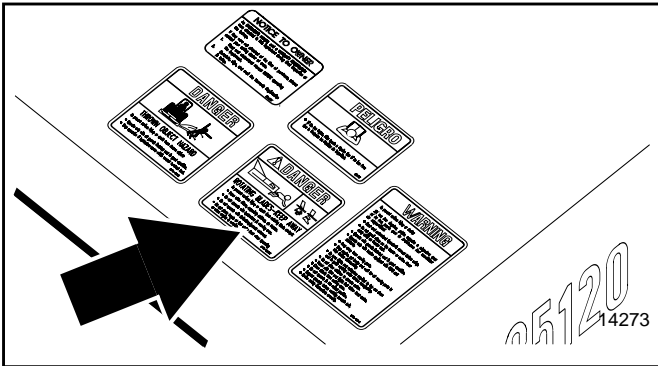

**818-555C**  
Danger Rotating Blade

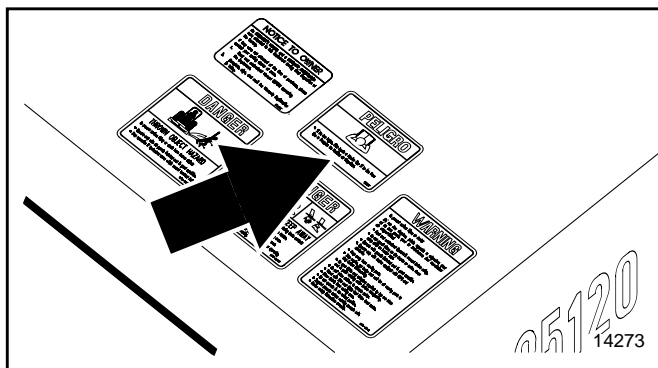

**818-556C**  
Danger Thrown Object

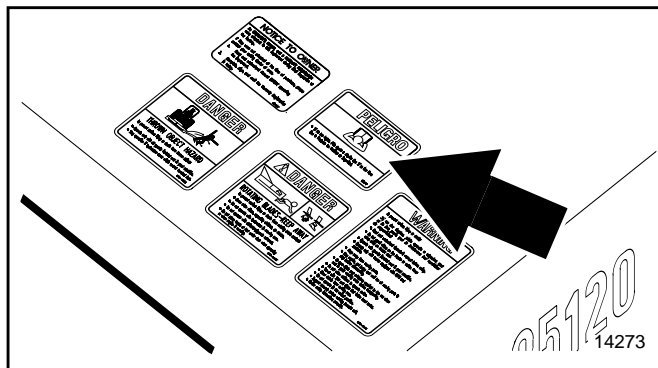

**818-557C**  
Notice To Owner

## Introduction

# Introduction

Land Pride welcomes you to the growing family of new product owners. This implement has been designed with care and built by skilled workers using quality materials. Proper assembly, maintenance, and safe operating practices will help you get years of satisfactory use from the machine.

## Using This Manual

This Operator's Section is designed to help familiarize you with safety, assembly, operation, adjustments, troubleshooting, and maintenance. Read this manual and follow the recommendations to help ensure safe and efficient operation.

The warranty sheet should be filled out by the owner and dealer at the time of purchase. After completion give the dealer the white copy and send the pink copy to Great Plains. Keep your copy in the manual for use when corresponding with the dealer.

To order a new Operator or Parts Manual contact your authorized dealer or write to the address listed below in the *Owner Assistance* paragraph. Include the model and serial numbers of your unit.

The information contained within this manual was current at the time of printing. Some parts may change slightly to assure you of the best performance.

### Terminology:

"Right" or "Left" as used in this manual is determined by facing the direction the machine will travel while in use unless otherwise stated.

### Definitions:

**NOTE:** A special point of information related to it's preceding topic. The author's intention is that you read and note this information before continuing.

**IMPORTANT:** Information, related to it's proceeding topic, that the author feels would be of use.

## Owner Assistance

If customer service or repair parts are required contact your local Land Pride dealer. He has trained personnel, repair parts, and the equipment needed to service your implement.

These parts have been specially designed and should

only be replaced with genuine Land Pride parts.

### Serial Number Plate

Refer to the Figure 1 for the location of your serial number plate.

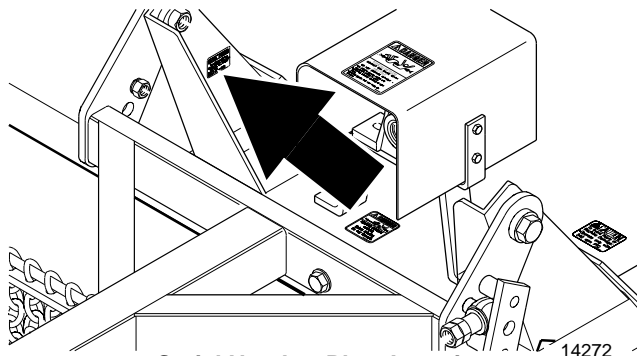

**Serial Number Plate Location**  
**Figure 1**

For prompt service always use the serial number and model number when ordering parts from your Land Pride Dealer. Be sure to include your serial and model numbers in correspondence also.

Your dealer wants you to be satisfied with your new machine. If for any reason you do not understand any part of this manual or are not satisfied with the service received, the following actions are suggested:

1. Discuss the matter with your dealership Service Manager make sure he is aware of any problems you may have and that he has had the opportunity to assist you.
2. If you are still not satisfied, seek out the Owner or General Manager of the dealership, explain the problem and request assistance.
3. For further assistance write to:

## Product Support

### Land Pride, Service Department

1525 East North Street

P.O. Box 5060

Salina, Ks. 67402-5060



## Section 1 Assembly and Setup

### Tractor Requirements

The lift-type cutter is designed with a category II hitch. Both Lift and Pull-Type Cutters are designed for tractors with a minimum PTO horsepower rating of 50 HP and maximum of 120 HP. Adequate front end weight is required on tractors for use with lift-type cutter.

### Lift-Type Cutter

Refer to Figure 1-1:

#### Hitch & Axle Assembly

NOTE: Do not tighten hardware until assembly is complete.

1. Assemble hitch straps (#1) to inside of lower hitch angles welded to cutter deck with 1 1/8" hitch pin (#2) lock washers (#3) and nuts (#4).
2. Install pivoting upper hitch (#5) to inside of hitch straps with hitch braces (#6) on the outside. Do not attach other end of hitch braces at this time. Install 1" x 6 1/2" long bolt (#7) and lock nut (#8). Do not tighten bolts at this time.
3. Attach axle assembly (#9) to rear of cutter:
  - a. Position axle as shown.
  - b. Attach axle on the right hand side of cutter with cylinder pivot lug (#10) and 1 1/2" x 1" x 1 7/8" long spacer (#11) on outboard side of pivot, and 1

1/2" x 1" x 1 1/8" long spacer (#12) and hitch brace (#6) on inboard side of pivot. Secure with a 1" x 9 1/2" long bolt (#13), flat washer (#14), and lock nut (#8).

- c. Attach axle on the left hand side of cutter with 1 1/2" x 1" x 1 1/8" long spacer (#12) on both sides of pivot attach hitch brace (#6) on inboard side of pivot. Secure with a 1" x 9" long bolt (#15), flat washer (#14), and lock nut (#8)
- d. Install outboard axle mounts (#33) to deck mounted support (#34) with pivot shaft pin (#35) and secure with 1/4" -20 x 1 1/2" long hex bolt (#36) and lock nut (#37).

NOTE: 1" bolts should be installed pointing outboard.

- e. Fasteners for hitch straps (#1) and pivoting upper hitch (#5) can now be tightened. Do not over tighten 1" x 6 1/2" long upper hitch bolt (#7). Upper hitch must be free to pivot.
4. If cutter is equipped with ratchet height adjustment:
  - f. Install ratchet (#16) and secure with pins and clips furnished with ratchet.
5. If cutter is equipped with hydraulic height adjustment:
  - g. Install 3 1/2" x 8" hydraulic cylinder (#17) and secure with 1" pins and clips furnished with cylinder.

## Section 1 Assembly and Setup

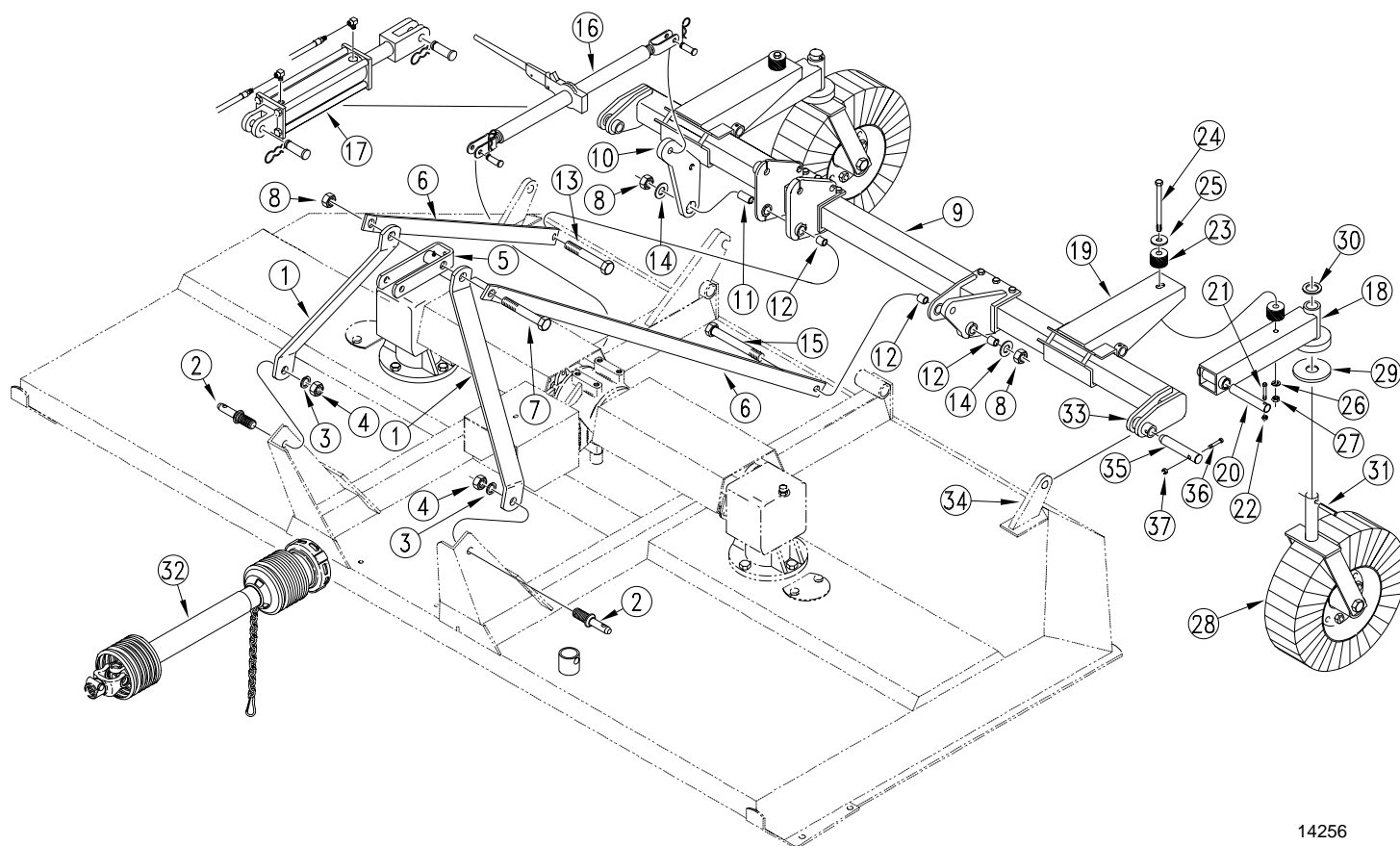

14256

**Hitch & Axle Assembly**  
Figure 1-1

### Tailwheel

#### Refer back to Figure 1-1:

1. Attach caster arm weldment (#18) to axle arm (#19) with 1" pin (#20) secure with 5/16" x 2" long bolt (#21) and lock nut (#22).
2. Install rubber bumpers (#23) one on top side of axle arm mount and one below as shown and secure with 1/2" x 8" long bolt (#24), rubber stop washer (#25), flat washer (#26), and lock nut (#27). Tighten lock nut until rubber bumper compresses to 1 3/4" as shown in Figure 1-2.
3. Attach tailwheel yoke spindle (#28) to caster arm weldment (#18) and secure with washer (#29) on bottom and washer (#30) on top and spiral roll pin (#31).

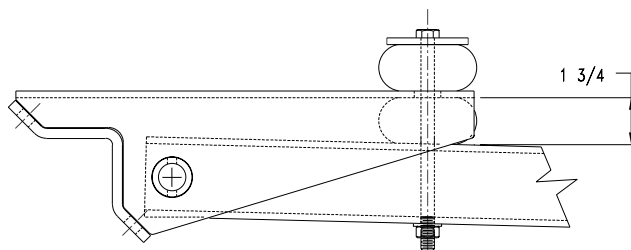

10440

**Rubber Bumper Tightening Dimensions**  
Figure 1-2

**Section 1 Assembly and Setup**

**Pull-Type Cutter**

**Tongue**

**Refer to Figure 1-3:**

1. Position tongue (#1) in front of cutter as shown. Block tongue in or near a horizontal position.
2. Assemble tongue to lower hitch plates welded to cutter deck with the 1 5/8" x 1 1/8" x 2" long spacers (#2), 1 1/8" x 4" long bolts (#3), and lock nuts (#17).
3. Attach safety chain (#4) to tongue (#1) using two 1" USS flat washers (#5) and 1" nylon lock nut (#6).
4. Install the hydraulic hose loop (#7) on the deck behind the right hand lower hitch plate using a 3/8" x 3/4" long bolt (#8), lock washer (#9), and flat washers (#10).
5. Install jack (#11) to tongue and secure with pin (#12).

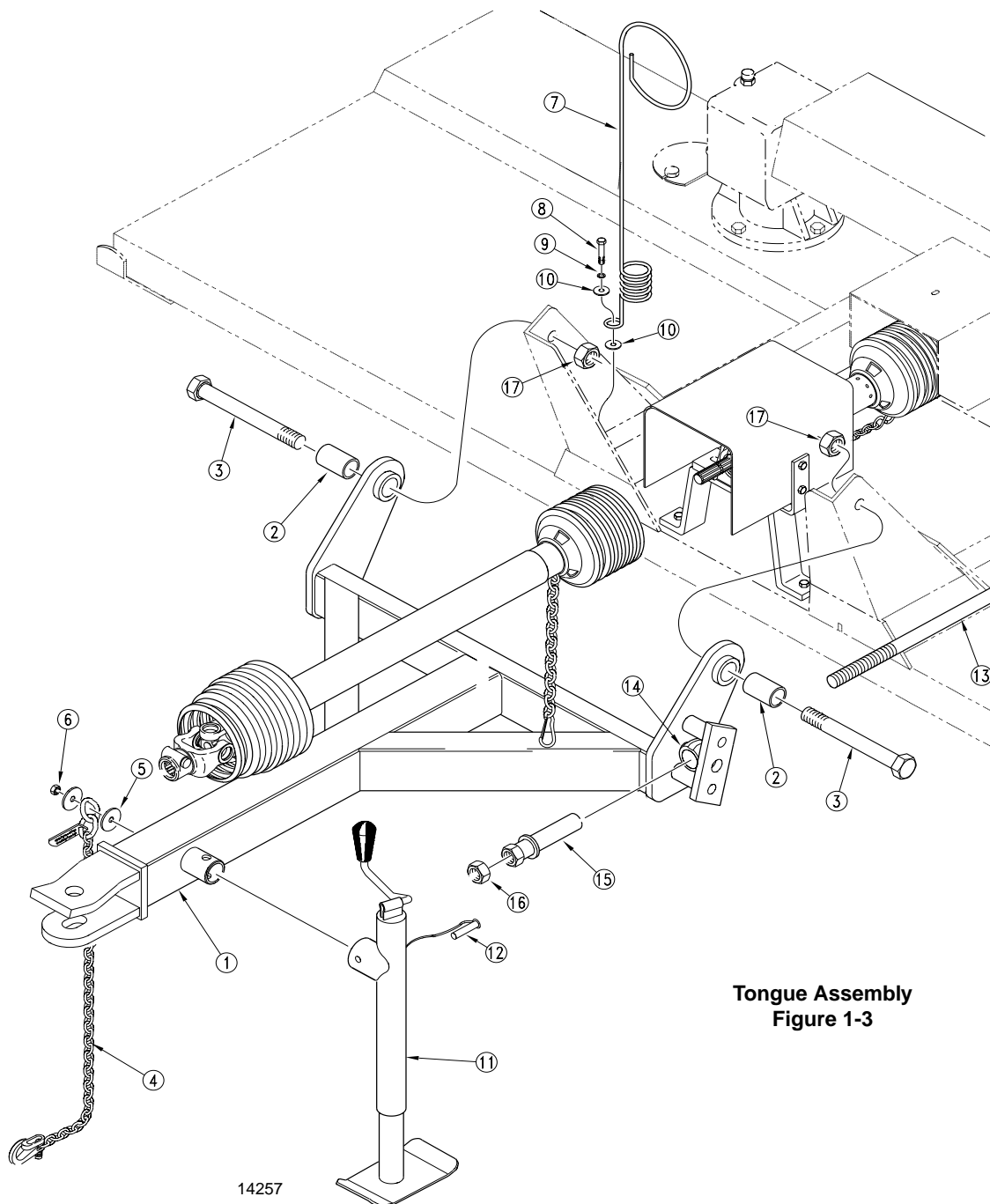

**Tongue Assembly  
Figure 1-3**

14257

## Section 1 Assembly and Setup

### Rear Axle

#### Refer to Figure 1-4:

1. Attach axle assembly (#1) to rear of cutter:
  - h. Position axle as shown.
  - i. Attach axle on the right hand side of cutter with cylinder pivot lug (#2) and 1 1/2" x 1 7/8" long spacer (#3) on outboard side of pivot, and 1 1/2" x 1" x 1 1/8" long spacer (#4) on inboard side of pivot. Secure with a 1" x 9" long bolt (#5), flat washer (#6), and lock nut (#7).
  - j. Attach axle on left hand side of cutter with 1 1/2" x 1" x 1 1/8" spacer (#4) on both sides of pivot. Secure with a 1" x 8 1/2" long bolt (#8), flat washer (#16), and lock nut (#7).
  - k. Install outboard axle mounts (#26) to deck mounted supports (#27) with pivot shaft pin (#23) and secure with 1/4" -20 x 1 1/2" long hex bolt (#25) and lock nut (#24).

NOTE: 1" bolts should be installed pointing outboard.

2. Install 3 1/2" x 8" hydraulic cylinder (#9) and secure with 1" pins and clips furnished with cylinder.
3. Route hoses (#10) through hydraulic hose loop (#7) Refer back to Figure 1-3.

### Tailwheel

#### Refer to Figure 1-4:

1. Attach axle arm weldment (#11) to axle arm mount with 1" pin (#12) and secure with 5/16" x 2" long bolt (#16) and lock nut (#14).

NOTE: Axle arms can be installed with wheels to the inboard or outboard side.

2. Install rubber bumpers (#15) one on top side of axle arm mount and one below and secure with 1/2" x 8" long bolt (#16), rubber stop washer (#17), flat washer (#19), and lock nut (#18). Tighten lock nut until rubber bumper compresses to 1 3/4". Refer to Figure 1-2.
3. Attach wheels with tires mounted (#20) or 15" rims (not shown) to hubs (#21) with 1/2" -20 x 1 1/8" long flange bolts (#22).

### Leveling Rod

#### Refer back to Figure 1-3:

NOTE: The leveling rod is to be installed on the left hand side of the cutter.

1. Insert leveling rod (#13) through trunnion (#14).
2. Screw leveling tube (#5) over leveling rod (#13) and secure with 1" jam nut (#16).
3. Refer to Figure 1-4, attach clevis end (#28) of leveling rod to lug (#29) tailwheel axle with 1" x 2" clevis pin (#30) and secure with hair pin clips (#31).

NOTE: The leveling rod should be adjusted to level the cutter after attaching cutter to tractor.

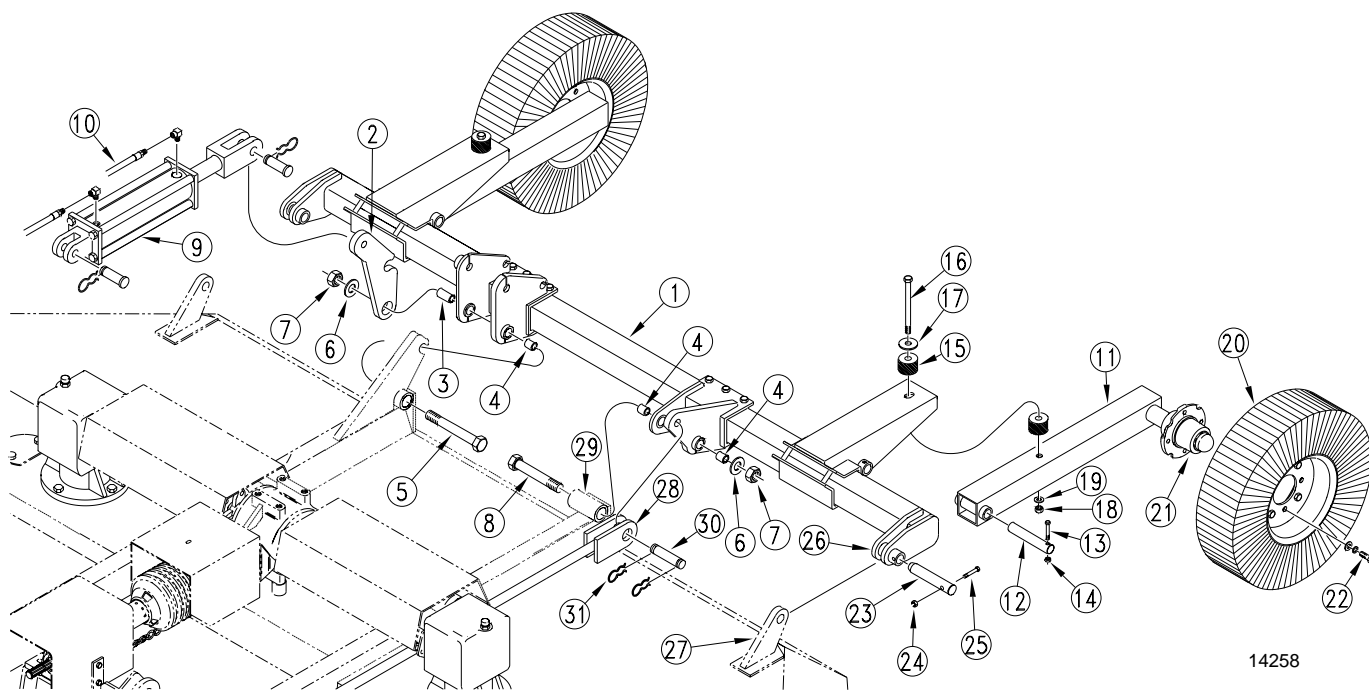

Pull-Type Tailwheel & Rear Axle Assembly  
Figure 1-4

## Section 1 Assembly and Setup

Safety Guards Assembly  
Figure 1-5

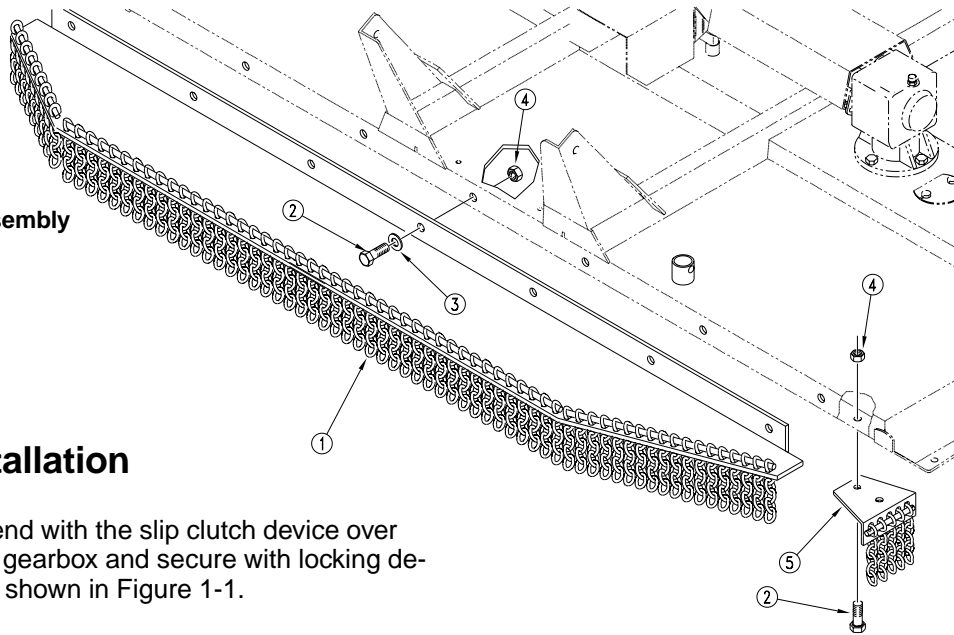

14259

## Driveline Installation

### Lift-Type Cutter

Slide the driveline end with the slip clutch device over splined shaft of the gearbox and secure with locking device of driveline, as shown in Figure 1-1.

### Pull-Type Cutter

Attach constant velocity driveline to stub shaft on jackshaft driveline and secure with locking device of PTO shaft, as shown in Figure 1-3.



## DANGER!

Rotary cutters have the ability to discharge objects at high speeds; therefore, the use of front safety shields is strongly recommended when cutting along highways or in an area where people may be present.

## Safety Guards

Refer to Figure 1-5:

1. Install chain guard (#1) to cutter front angle using 1/2" x 1 1/2" long hex bolts (#2), flat washers (#3), & nuts (#4).
2. Install side chain mounts (#5) to underside of front angle using 1/2" x 1 1/2" long hex bolts (#2) and nuts (#3).

2. Align lower link arms of tractor to hitch pins on cutter. Insert lower hitch pins into lower ball swivels on tractor and secure with lynch pins (furnished by the customer).
3. Adjust and attach tractor top link to pivoting upper hitch on cutter with pin supplied. Secure with hair pin cotter.
4. If the cutter is equipped with optional hydraulic height adjustment, connect cylinder hoses to tractor remote outlets.
5. Adjust tractor top link until upper hitch pin is aligned vertically with lower hitch pins, refer to Figure 1-7.

## Tractor Hook-Up

Refer to Figure 1-6:

### Lift-Type Cutter

1. Be certain that tractor draw bar will not interfere. Move draw bar ahead, aside or remove if required. Draw bar should also be checked for clearance when unit is being raised for the first time.

Lift-Type Tractor Hook-Up  
Figure 1-6

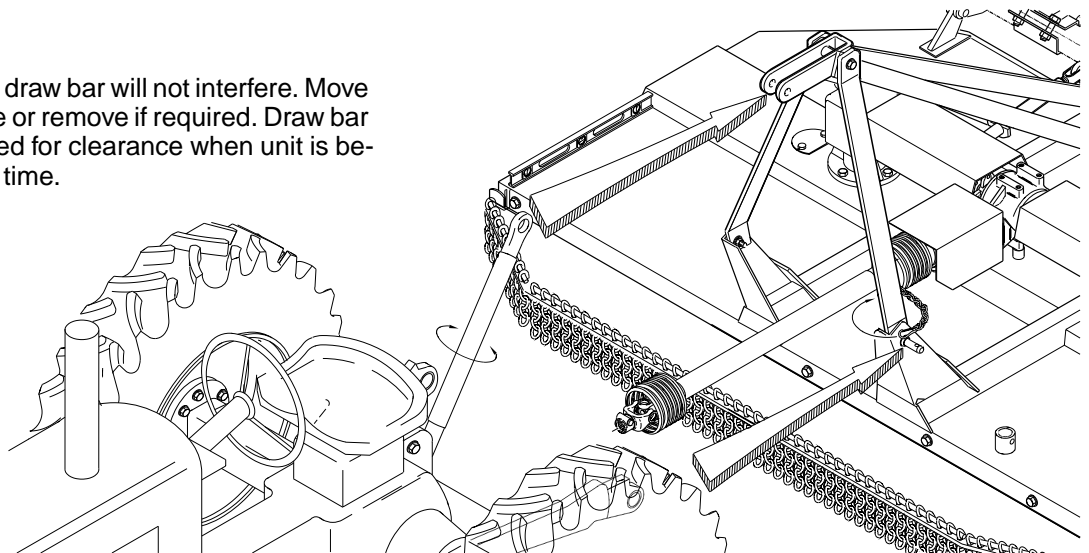

14261

## Section 1 Assembly and Setup

NOTE: Chain should be attached to PTO at implement end of shaft.

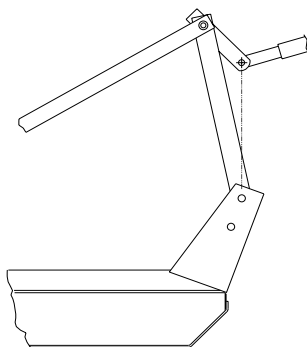

**Top Link Alignment**  
Figure 1-7

11420

6. Slide PTO shaft over the tractor's splined PTO shaft and secure with locking device of PTO shaft.
7. Secure chain on PTO to hitch brace on cutter to restrict outer shield of PTO from rotating.
8. PTO shaft should now be moved back and forth to insure that it is secured to the shafts of the tractor and cutter gearbox.

### Refer to Figure 1-8:

9. Should the PTO shaft require shortening:
  - a. Hold the half shafts next to each other in the shortest working position and mark them.
  - b. Shorten inner and outer guard tubes equally.
  - c. Shorten inner and outer sliding profiles by the same length as the guard tubes.
  - d. Proper overlap is a minimum of one-half the length of each tube, with both tubes being of equal length.
  - e. Round off all sharp edges and remove burrs. Grease sliding profiles.

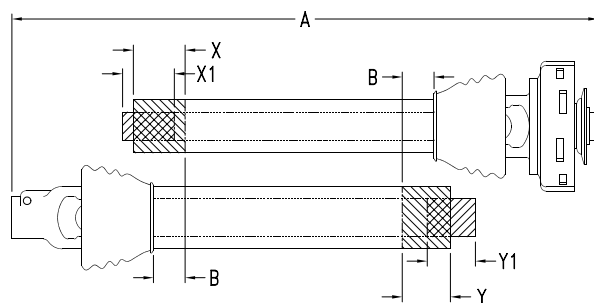

**Shortening PTO Shafts**  
Figure 1-8

13588

### Refer to Figure 1-9:

9. If check chain kit is purchased, assemble to cutter.

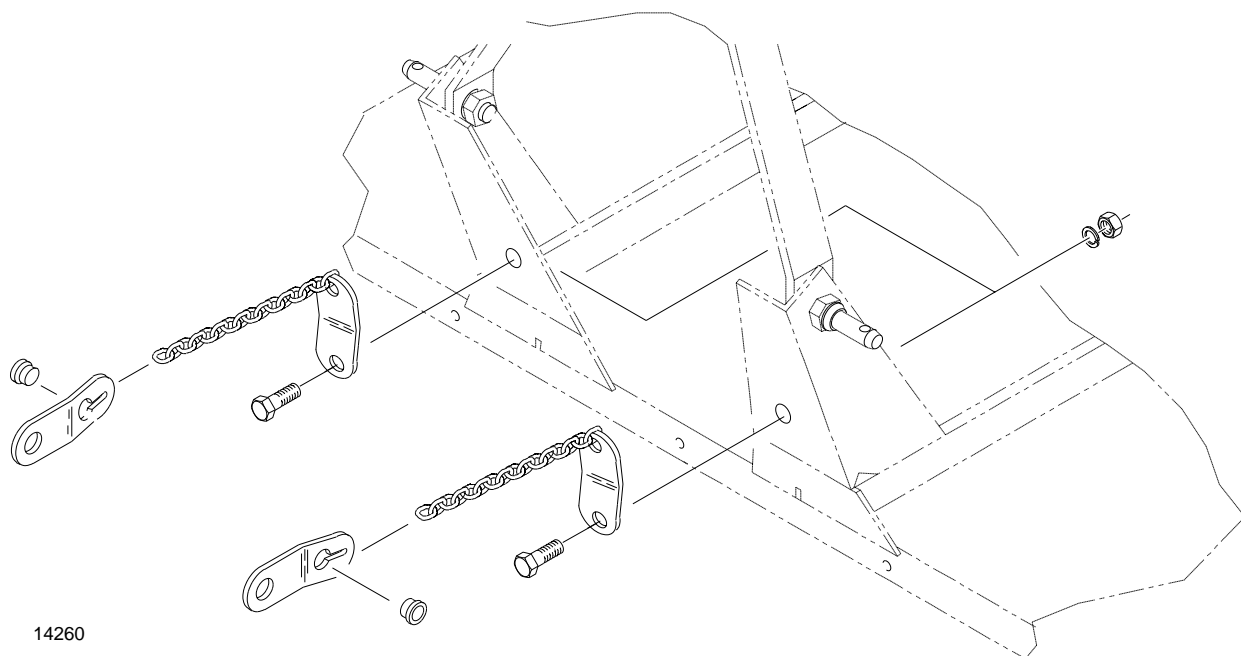

14260

**Check Chain Assembly**  
Figure 1-9

## Section 1 Assembly and Setup

### Pull-Type Cutter

#### Refer to Figure 1-10:

1. Back off leveling rod jam nut, (#16) and leveling tube nut (#15) on leveling rod.
2. Raise tongue off the ground manually and support tongue with screw jack.
3. Back the tractor up to the tongue until holes in drawbar and cutter hitch are aligned.
4. Attach cutter with 1 1/4" hitch pin and secure with lock pin. Always use a pin that contains a safety locking device to prevent it from falling out.
5. Place tongue jack in a horizontal position on the jack mount located on the left front of cutter deck.
6. Tighten leveling tube nut until it bottoms out on trunnion. Turn nut additional 2 or 3 turns and tighten jam nut.
7. Connect cylinder hoses to tractor remote outlets.
8. Attach safety chain on tongue hitch to tractor and lock hook securely on chain. Adjust chain length to remove all slack except what is necessary to permit turning of the cutter.
9. Slide PTO shaft over tractor's splined shaft and secure with locking device of PTO shaft.

10. Secure chain on PTO around cutter tongue to restrict outer shield of PTO from rotating. Leave adequate length of chain loose for turning.

**NOTE:** Chain should be attached to PTO at implement end of shaft.

11. PTO should now be moved back and forth to insure that it is secured on the shaft of the tractor and stub shaft on the cutter.
12. Should the PTO shaft require shortening:

#### Refer back to Figure 1-8:

- a. Hold the shafts next to each other in the shortest working position and mark them.
- b. Shorten inner and outer guard tubes equally.
- c. Shorten inner and outer sliding profiles by the same length as the guard tubes.
- d. Proper overlap is a minimum of one-half the length of each tube, with both tubes being of equal length.
- e. Round off all sharp edges and remove burrs. Grease sliding profiles.

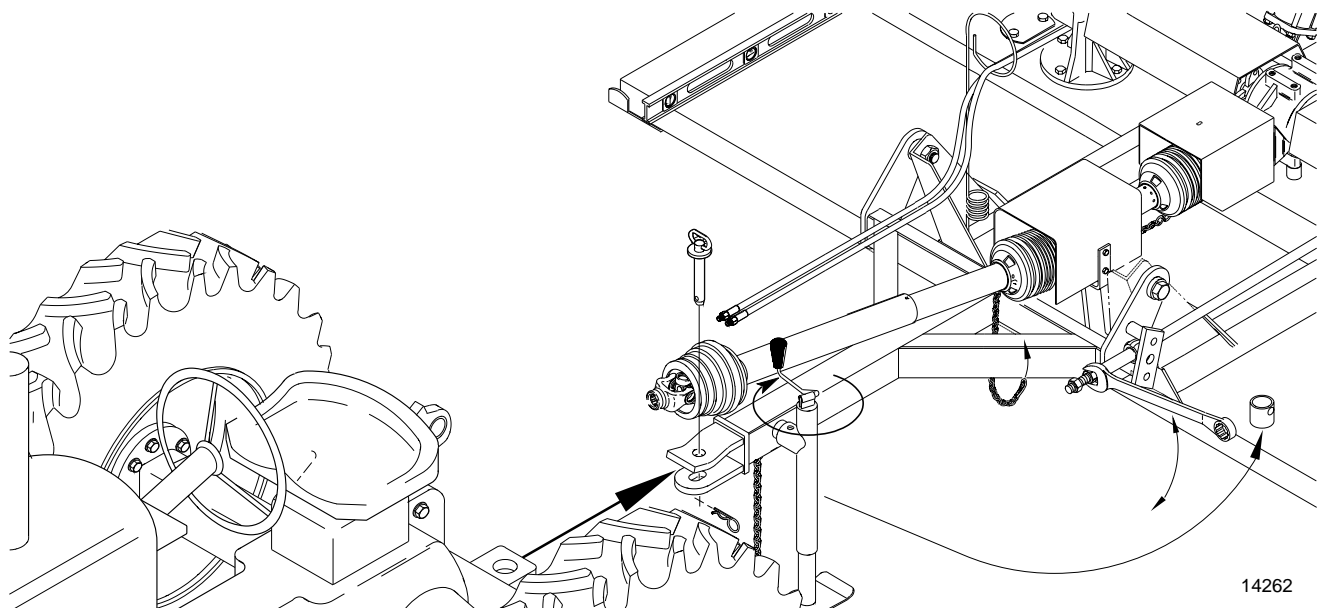

**Pull-Type Tractor Hook-Up**  
**Figure 1-10**

## Section 2 Operating Instructions

### Section 2 Operating Instructions

#### Transporting

##### **CAUTION!**

When traveling on public roads whether at night or during the day, use accessory lights and devices for adequate warning to operator's of other vehicles. Comply with all Federal, State and Local laws.

##### **CAUTION!**

Always disengage tractor PTO before transporting cutter to avoid injury from thrown objects or blade contact.

1. On a lift-type cutter, when raising to transport position, be certain that PTO shaft does not contact tractor or cutter.
2. Refer to Figure 2-1. The pull-type cutter is equipped with a transport lock pin. Remove pin and hair pin cotter from storage position and install in locking position before transporting.

NOTE: Hydraulic cylinder may be removed if necessary when transport lock pin is in lock position.

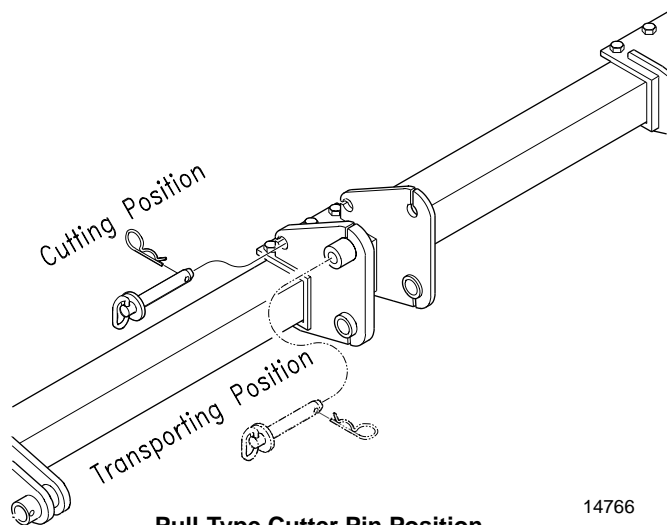

**Pull-Type Cutter Pin Position**  
Figure 2-1

3. Reduce tractor ground speed when turning; be sure tractor wheel does not contact cutter when turning. Leave clearance so cutter does not contact obstacles such as buildings, trees or fences.
4. The cutter should be transported no faster than 15 mph when equipped with laminated tires, and 20 mph when equipped with pneumatic tires.
5. When traveling on roadways, transport in such a way that faster moving vehicles may pass you safely.

##### **CAUTION!**

The cutter is 10' 8" wide and care should be taken when encountering oncoming traffic and roadside obstructions.

#### Operating Check List

In addition to design and configuration of equipment; hazard control and accident prevention are dependent upon the awareness, concern, prudence and proper training involved in their operation, transport, maintenance and storage of equipment. Before beginning to cut the following inspection should be performed.

Check	Reference
<input type="checkbox"/> "Safety Rules" in this Manual.	Page 1
<input type="checkbox"/> Check oil level in gearboxes.	Section 5 Page 22
<input type="checkbox"/> Check that all plugs in gearbox have been replaced properly.	Section 5 Page 22
<input type="checkbox"/> Be sure nuts and bolts are tight.	Section 1
<input type="checkbox"/> Be certain all guards and shields are in place.	Section 1 Page 11
<input type="checkbox"/> Lubricate the cutter as needed. Refer to "Maintenance and Lubrication".	Section 5 Page 19

##### **CAUTION!**

To prevent personal injury caused by thrown objects, the use of front & rear safety guards is strongly recommended! To avoid injury or death from entanglement in rotating drivelines, the drive gearbox shields must be in place and secure when operating.

##### **DANGER!**

Rotary cutters have the ability to discharge objects at high speeds; therefore, the use of front & rear safety shields is strongly recommended when cutting along highways or in an area where people may be present.

#### Cutting Instructions

1. Your cutter is equipped with free swinging cutting blades to reduce shock loads to the cutter if striking obstacles.
2. Start the machine slowly; do not use full throttle. Allow 10 seconds for cutter blades to become aligned properly before going to full power.
3. The ground speed depends on two things; the density of the material to be cut, and the size of the tractor. Never run fast enough to overload the tractor.
4. It is important to maintain 540 RPM PTO or 1000 RPM speed. Loss of PTO speed will allow the blades to hinge back and result in ragged, uneven cutting.



## Section 2 Operating Instructions

---

5. This cutter was designed to cut grass and light brush in right-of-ways, pastures and for shredding row crop residues.



### **CAUTION!**

*Damage may occur if exceeding the cutting capacity of the cutter!*



### **CAUTION!**

*Do not over speed PTO or machine damage may result. This cutter (RC35120) designed to be used only with a tractor having a 540 RPM rear PTO. The RCM35120 is designed to be used with a tractor having a 1000 RPM PTO.*

## Section 3 Adjustments

### Section 3 Adjustments

#### Lift-Type Cutting Height

Refer to Figure 3-1:



#### CAUTION!

Engage parking brake, shut off tractor, remove key and disengage PTO before making any height adjustments!

1. Lower cutter onto safely supported blocks to desired cutting height. Be certain cutter is level.
2. If cutter is equipped with optional hydraulic height adjustment, connect cylinder hoses to tractor remote outlets.
3. Adjust the cutting height using ratchet jack or hydraulically if equipped with hydraulic cylinder.

4. Adjust the tractor's lower 3-point hitch arms to level cutter left to right. Set tractor 3-point depth stop when cutter is level to maintain a consistent mowing weight.

#### Pull-Type Cutting Height

1. The cutting height can be adjusted by extending or retracting the hydraulic cylinder to the desired cutting height.

Lift-Type Cutting Height Adjustment  
Figure 3-1

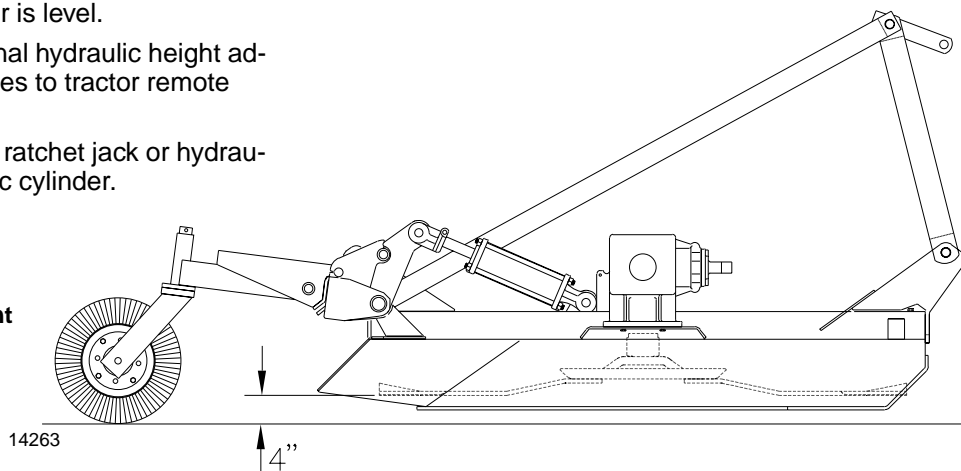

2. Once the cutter has been leveled, it will remain level regardless of change in cutting height unless tractor drawbar height or tailwheel size is changed.
3. Should the cutter require additional leveling adjustment:
  - a. Turn nut on leveling tube counterclockwise to lower front of cutter and clockwise to raise front of cutter.
  - b. Secure with jam nut.

#### Deck Attitude Adjustment

Refer to Figure 3-2:

This adjustment is very important. With the deck positioned at this attitude, the blades will be cutting material only at the front of the cutter. If the deck is level, or the rear of the cutter is lower than the front, the blades are subject to continuous material flow which results in additional blade wear and horsepower loss as well as more frequent blade sharpening.

Deck Attitude Adjustment  
Figure 3-2

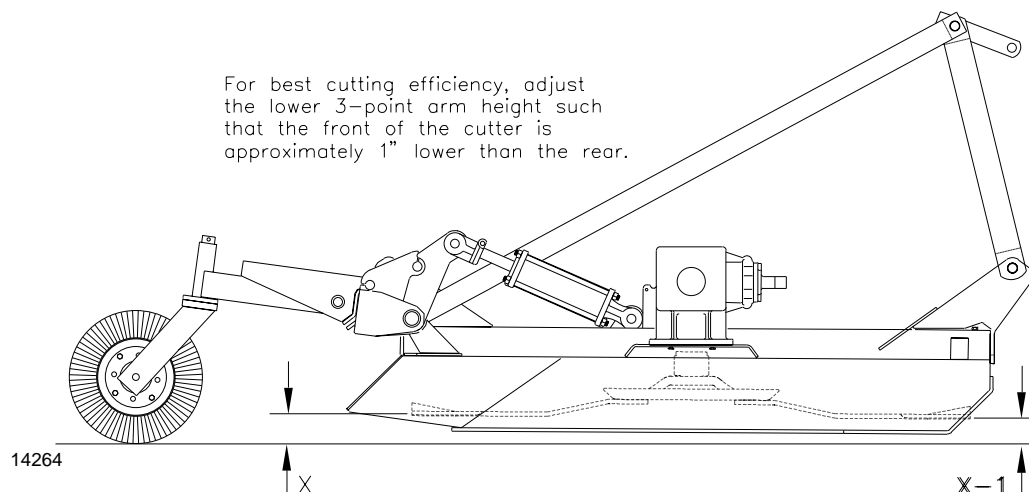

## Section 4 Troubleshooting

Problem	Cause	Solution
<b>Oil seal leaking</b>	Gearbox overfilled	Drain to side plug hole.
	Seals damaged	Replace seals
	Grass or wire wrapped on shaft in seal area	check seal areas daily
<b>Driveline yoke or cross failing</b>	Shock load	Avoid hitting solid objects
	Needs lubrication	Lubricate every 8 hours.
<b>Driveline clutch slipping</b>	Scalping the ground	Raise cutting height
	Cutting too fast	Reduce travel speed
	PTO being engaged too fast at high engine rpm	Slowly engage PTO at low engine rpm
	Cutting over solid objects	Avoid solid objects
<b>Bent Driveline (NOTE: driveline should be repaired or replaced if bent)</b>	Contacting frame	Reduce lift height in transport position
	Contacting drawbar	Reposition drawbar
	Bottoming out	Shorten driveline
<b>Driveline telescoping tube failing</b>	Shock load	Avoid hitting solid objects
<b>Driveline telescoping tube wearing</b>	Needs lubrication	Lubricate every 50 hours
<b>Blades wearing excessively</b>	Cutting on sandy ground	Raise cutting height
	Contacting ground frequently	Raise cutting height
<b>Blades breaking</b>	Hitting solid objects	Avoid hitting solid objects
	Blades hitting each other	Blade carriers need to be timed
<b>Blades coming loose</b>	Blades not tightened properly	Tighten blade hardware (refer to "Servicing Cutter Blades" on page 16.
<b>Blade carrier becomes loose</b>	Running loose in the past	Replace gearbox output shaft and blade carrier
	Blade carrier hardware not tight enough	Tighten to specified torque
<b>Blade bolt holes worn</b>	Blade hardware running loose	Replace blades and blade bolts if worn
<b>Blade carrier bent</b>	Hitting solid objects	Avoid hitting solid objects and replace blade carrier
<b>Excessive side skid wear</b>	Cutting height not level	Adjust cutter height
	Soil abrasive	Adjust cutter height
	Cutting too low	Adjust cutter height
<b>Tail wheel support failing</b>	Lowering too fast	Adjust rate of drop
	Hitting objects when turning	Reduce speed on turns

## Section 4 Troubleshooting

---

Problem	Cause	Solution
Excessive vibration	Driveline bent	Replace driveline
	Blades loose	Tighten blade bolts
	Blade carrier bent	Replace blade carrier
	Blade broken	Replace blade
	Blade will not swing	Remove and inspect blade
	Blades have unequal weight	Replace both blades
	Blades locked together	Unlock blades

## Section 5 Maintenance and Lubrication

### Maintenance

Proper servicing and adjustment is the key to the long life of any farm implement. With careful and systematic inspection, you can avoid costly maintenance, time and repair.

After using your Rotary Cutter for several hours, check all bolts to be sure they are tight.

Replace any worn, damaged or illegible safety decals by obtaining new decals from your Land Pride Dealer.

### Service Cutting Blades

- Both blades on each dishpan should be sharpened at the same angle as the original cutting edge and must be replaced or reground at the same time to maintain proper balance in the cutting unit.

NOTE: Replace blades with genuine Land Pride parts only.

NOTE: Care should be taken in order not to remove any more material than necessary when sharpening blades.

- Both blades on each dishpan should weigh the same after sharpening.
- When replacing or sharpening the cutter blades, examine bolts for excessive wear and replace if necessary. To replace blades:
  - Order blade bolt Land Pride part # 802-277C, clockwise blade part # 820-076C, and counter-clockwise blade part # 820-075C.
  - Torque blade bolt lock nut to 450 ft. pounds. An extended cheater bar may be required to achieve proper torque.
  - Carefully check the cutting edges of the blades in relation to the blade carrier rotation, below to insure correct blade placement.
- Blade dishpan replacement:

#### Refer to Figure 5-1:

- Blades must be indexed 90° to one another to prevent blade collision.
- Dishpan nut on gearbox output shafts should be torqued to 450 ft. pounds and cotter pin installed in nut with legs bent around.

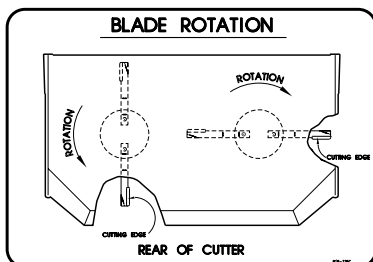

Blade Rotation  
Figure 5-1

### CAUTION!

Engage parking brake, disengage PTO, shut off tractor, and remove key before making any of the following adjustments.

### Skid Shoe Service & Replacement

- Check skid runners and skid shoes for wear and replace if necessary. Order skid shoe Land Pride part # 312-175D or 312-079A (1 set with hardware).

### WARNING!

Excessive wear on skids may cause inadequate operation of cutter and create a safety hazard!

- Plow bolts should be checked for wear and replaced if necessary. Order Land Pride part # 802-020C.

#### Refer to Figure 5-2:

- To replace skid shoes:
  - Remove existing skid shoes.
  - Attach skid shoe to cutter, using four 3/8" plow bolts, flat washers and lock nuts.
  - Repeat on opposite side of cutter.

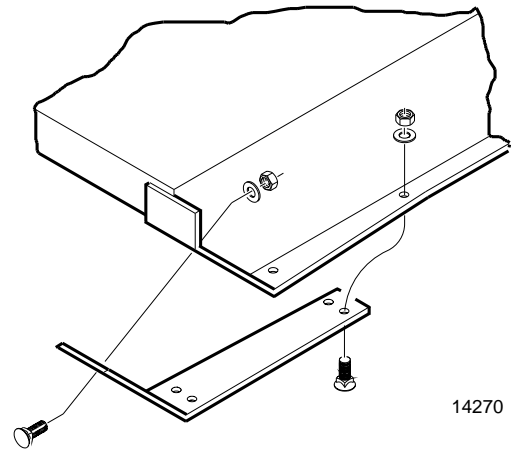

Skid Shoe Replacement  
Figure 5-2

### Flex Couplers

#### Refer to Figure 5-3:

- Disks (#1) and beaded washers (#2) should be replaced if disassembling flex coupler shaft.
- When replacing disks; bolts (#3) and nuts (#4) should be tightened evenly with nuts torqued 35 to 40 ft. pounds. Beaded washers (#4) should be imbedded

## Section 5 Maintenance and Lubrication

halfway into disks.

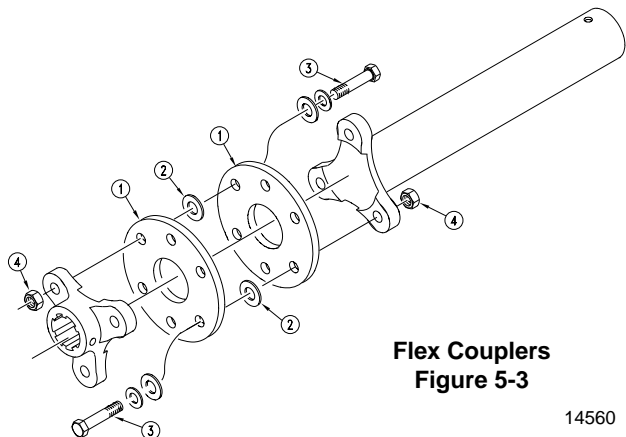

**Flex Couplers**  
Figure 5-3

14560

### Clutch Run-In

Refer to Figure 5-4:

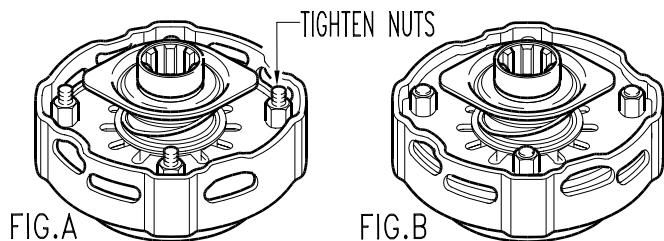

**Clutch Run-In**  
Figure 5-4

10103

The clutch should slip during operation to protect the cutter from excessive loads.

Prior to initial operation and after long periods of inactivity, the Friction Clutch should be "run-in".

1. Tighten all 4 nuts uniformly until the spring load is low enough that the clutch slips freely with the PTO engaged.
2. Turn nuts fully back. Clutch is ready for use.

### Storage

At the end of the working season or when the cutter will not be used for a long period, it is good practice to clean off any dirt or grease that may have accumulated on the cutter and any of the moving parts.

1. Clean the Rotary Cutter as necessary.
2. Check the blades for wear and replace if necessary.
3. Inspect the cutter for loose, damaged or worn parts and adjust or replace as needed.
4. Lubricate as noted in "Lubrication", below.
5. Store the Rotary Cutter inside if possible for longer Rotary Cutter life.
6. Repaint parts where paint is worn or scratched to prevent rust. Ask your dealer for Aerosol Land Pride Beige touch-up paint #821-011C.

## Lubrication

<b>Lubrication Legend</b>	Multipurpose spray lube	Multipurpose grease lube	Multipurpose oil lube	Intervals at which lubrication is required

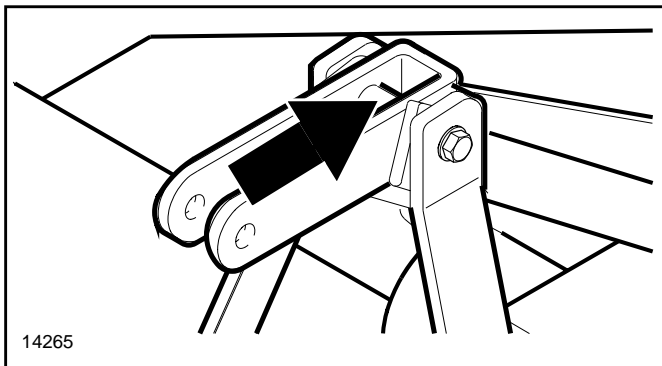

14265

--	--

### Pivoting Upper Hitch

Type of Lubrication: Multipurpose Grease  
Quantity = 6 pumps

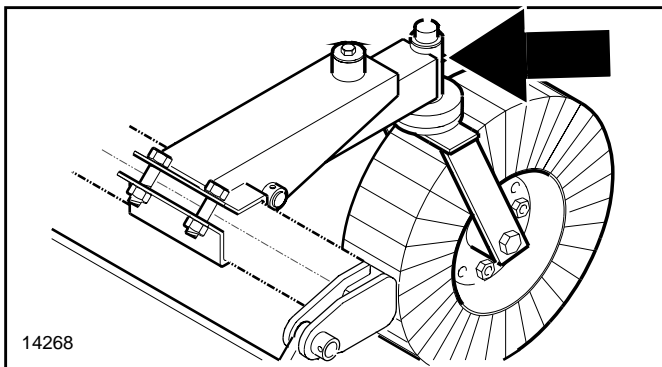

14268

--	--

### Lift-Type Tailwheel Spindle Hub

Type of Lubrication: Multipurpose Grease  
Quantity = 6 pumps

**Section 5 Maintenance and Lubrication**

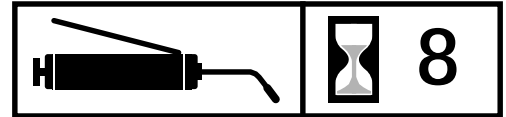
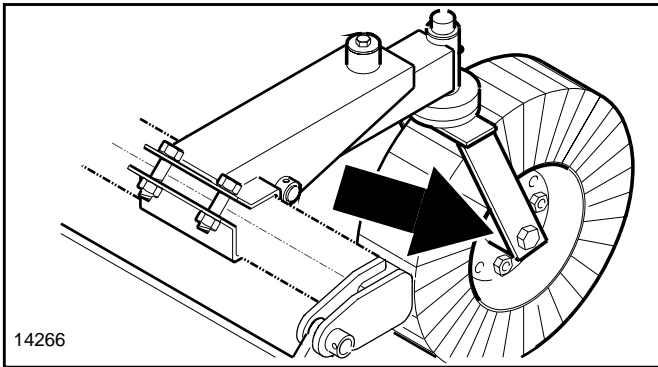

**Lift-Type Tailwheel Hub**

The tailwheel hub is equipped with a relief hole located directly opposite the grease fitting. The relief hole releases pressure from inside the hub casting when it is greased. The hub should be greased until grease purges from the relief hole.

Type of Lubrication: Multipurpose Grease

Quantity = Until grease purges from the relief hole

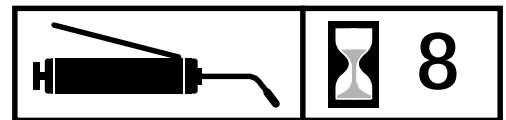
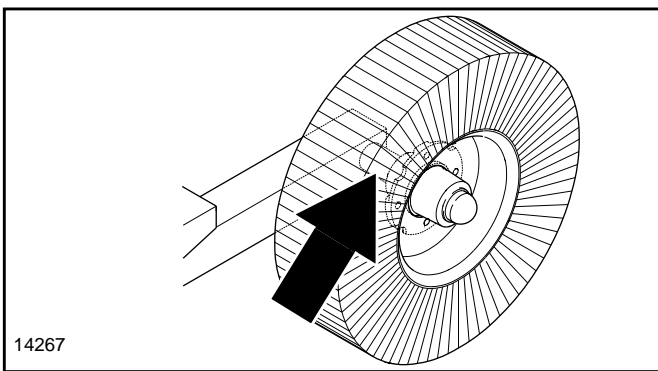

**Pull-Type Tailwheel Hub**

The tailwheel hub is equipped with a relief hole located directly opposite the grease fitting. The relief hole releases pressure from inside the hub casting when it is greased. The hub should be greased until grease purges from the relief hole.

Type of Lubrication: Multipurpose Grease

Quantity = Until grease purges from the relief hole

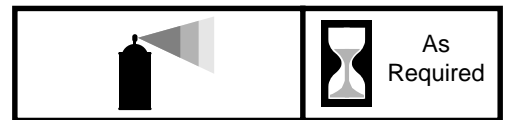
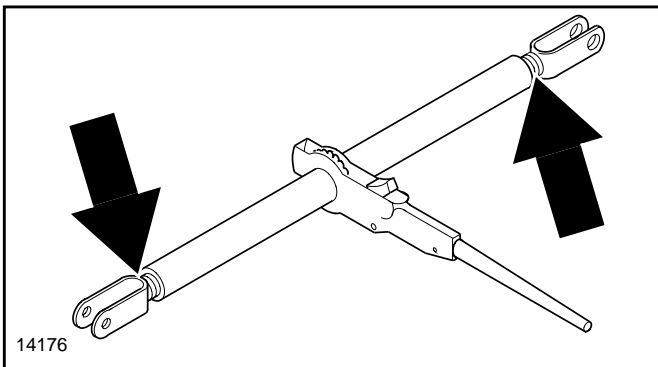

**Ratchet Jack**

Type of Lubrication: Multi-Purpose

Quantity = As required

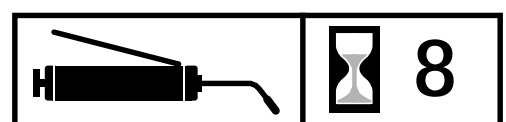
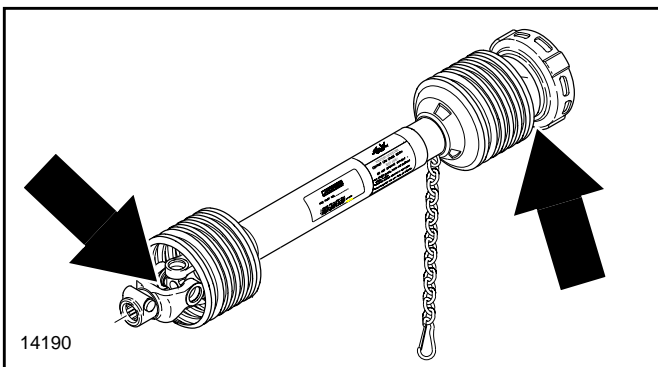

**Driveline U-Joints**

Type of Lubrication: Multipurpose Grease

Quantity = 6 pumps

**Section 5 Maintenance and Lubrication**

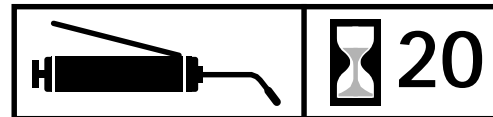
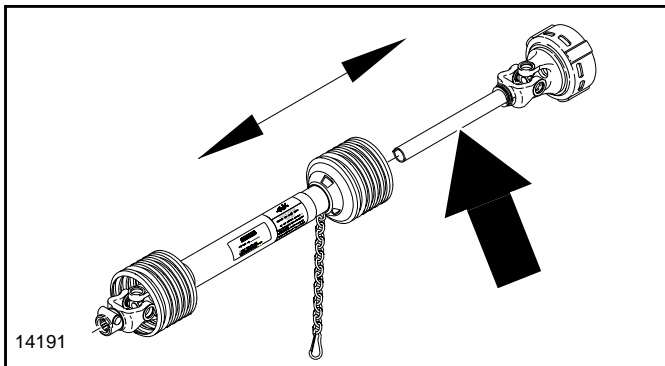

**Driveline**

Disconnect driveline from the tractor and slide apart

Quantity = Clean & coat the inner tube of the driveline with a light film of grease and then reassemble

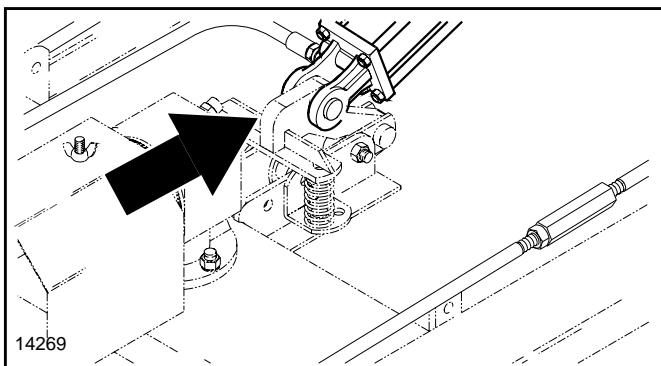

**Gearbox**

Check oil level in the gearbox by removing the side plug in the gearbox case. If the oil level is low, remove the top plug in the gearbox case and fill with EP90 oil until oil flows from the side port of gearbox case. Reinstall plugs and tighten.

NOTE: Do not overfill! Cutter should be level when checking oil.

Type of Lubrication: EP90 Oil

Quantity = fill until oil flows from the side port of gearbox case.

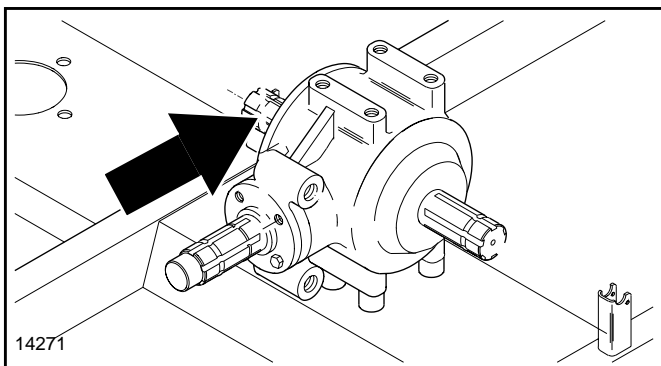

**T-Box**

Check oil level in the t-box by removing the side plug in the t-box case. If the oil level is low, remove the top plug in the t-box case and fill with EP90 oil until oil flows from the side port of t-box case. Reinstall plugs and tighten.

NOTE: Do not overfill! Cutter should be level when checking oil.

Type of Lubrication: EP90 Oil

Quantity = fill until oil flows from the side port of t-box case.



**Section 5 Maintenance and Lubrication**

**4-Plate Slip Clutch**

NOTE: Before proceeding, secure the clutch firmly in a vise or other clamping device to prevent injury.

**Disassembly**

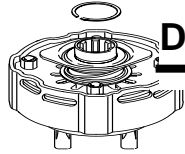

◀ **Step 1**  
Remove snap ring.

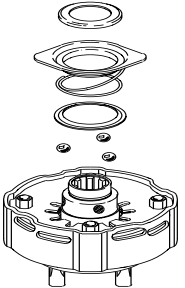

◀ **Step 2**  
Remove backup ring, lock collar, compression spring, bottom backup ring, and balls.

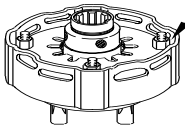

◀ **Step 3**  
Tighten the four hex nuts uniformly until the clutch pack and hub are loose.

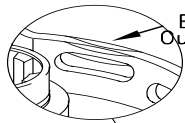

◀ **Step 4**  
Bend all four retaining lugs out on the edge of the clutch housing.

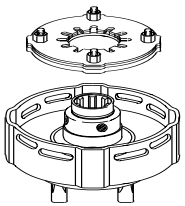

◀ **Step 5**  
Remove the thrust plate with the Belleville Springs and lug rings to access friction disks and hub for inspection or service.

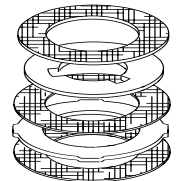

◀ **Step 6**  
Inspect friction disks and hub.

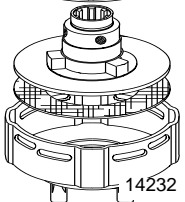

14232

**Assembly**

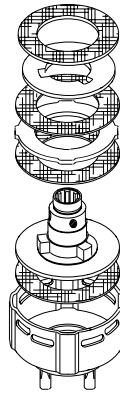

◀ **Step 1**  
Place the hub and friction disks into the housing.

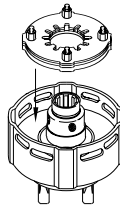

◀ **Step 2**  
Compress the Belleville Springs to the pressure plate by tightening the four hex nuts and then placing the assembly into the clutch housing.

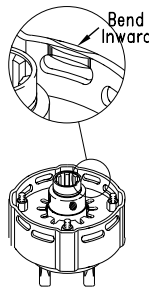

◀ **Step 3**  
Bend the retaining lugs inward over the Belleville Spring edges to secure the spring before backing the four hex nuts off.

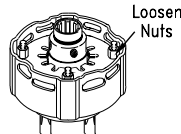

◀ **Step 4**  
With the lugs bent in, loosen the four hex nuts completely to the end of the threaded studs.

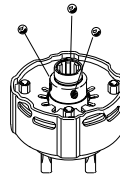

◀ **Step 5**  
Insert greased balls.

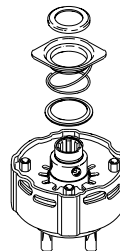

◀ **Step 6**  
Install bottom backup ring, compression spring, lock collar, and top backup ring.

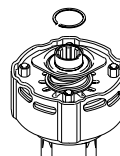

◀ **Step 7**  
Install snap ring.

14233

## Section 6 Specifications and Capacities

### Section 6 Specifications and Capacities

<b>Model</b>	RC35120 & RCM35120
<b>Cutting Width</b>	120"
<b>Overall Width</b>	128"
<b>Cutting Height</b>	2" - 14"
<b>Overall Length (Including Tailwheel)</b>	Lift-Type 106" Pull-Type 165"
<b>Weight</b>	Lift-Type - 2116# Pull-Type - 2300#
<b>Blade Tip Speed</b>	540 RPM PTO: 12,800 FPM / 788 RPM / 145 MPH 1,000 RPM PTO: 13,417 FPM / 826 RPM / 152 MPH
<b>T-box</b>	540 Or 1,000 RPM PTO Driven 1:1 Ratio Beveled Gears Cast Iron Housing 100 HP
<b>Wing Boxes</b>	540 RPM PTO Driven 1:1.46 Speed-Up 1,000 RPM PTO Driven 1.21:1 Reduction Beveled Gears Cast Iron Housing 80 HP
<b>Recommended Tractor PTO HP</b>	Lift-Type - 60 - 120 Pull-Type - 50 - 120
<b>Hitch</b>	Lift-Type - Category II 3-Point Pull-Type - Self Leveling
<b>Deck Material Thickness</b>	3/16"
<b>Deck Height (Bottom of Deck to Bottom of Skid Shoe)</b>	8 1/2"
<b>Blades (4) (2 per carrier)</b>	1/2" x 4" Heat Treated Alloy Steel Free-Swinging Suction Blades
<b>Blade Holders</b>	Round Pan 3/16" x 21 1/2"
<b>Drive Shaft</b>	ASAE Category 4
<b>Slip Protection</b>	4 Plate Slip Clutch on T-Box Rubber Flex Coupler to Wing Boxes
<b>Tailwheel</b>	Lift-Type - 4.00 x 8 x 15 1/4 Laminated Tires Pull-Type - 6.00 x 9 x 21 Laminated or 5 x 15 Rim
<b>Gauge Wheel Shock Load Protection</b>	Four Shock Absorbing Rubber Bumpers

# Section 7 Appendix

## Torque Values Chart for Common Bolt Sizes

Bolt Size (Inches)	Bolt Head Identification						Bolt Size (Metric)	Bolt Head Identification					
	Grade 2		Grade 5		Grade 8			5.8		8.8		10.9	
	N · m <sup>2</sup>	ft-lb <sup>3</sup>	N · m	ft-lb	N · m	ft-lb		N · m	ft-lb	N · m	ft-lb	N · m	ft-lb
1/4" - 20	7.4	5.6	11	8	16	12	M 5 X 0.8	4	3	6	5	9	7
1/4" - 28	8.5	6	13	10	18	14	M 6 X 1	7	5	11	8	15	11
5/16" - 18	15	11	24	17	33	25	M 8 X 1.25	17	12	26	19	36	27
5/16" - 24	17	13	26	19	37	27	M 8 X 1	18	13	28	21	39	29
3/8" - 16	27	20	42	31	59	44	M10 X 1.5	33	24	52	39	72	53
3/8" - 24	31	22	47	35	67	49	M10 X 0.75	39	29	61	45	85	62
7/16" - 14	43	32	67	49	95	70	M12 X 1.75	58	42	91	67	125	93
7/16" - 20	49	36	75	55	105	78	M12 X 1.5	60	44	95	70	130	97
1/2" - 13	66	49	105	76	145	105	M12 X 1	90	66	105	77	145	105
1/2" - 20	75	55	115	85	165	120	M14 X 2	92	68	145	105	200	150
9/16" - 12	95	70	150	110	210	155	M14 X 1.5	99	73	155	115	215	160
9/16" - 18	105	79	165	120	235	170	M16 X 2	145	105	225	165	315	230
5/8" - 11	130	97	205	150	285	210	M16 X 1.5	155	115	240	180	335	245
5/8" - 18	150	110	230	170	325	240	M18 X 2.5	195	145	310	230	405	300
3/4" - 10	235	170	360	265	510	375	M18 X 1.5	220	165	350	260	485	355
3/4" - 16	260	190	405	295	570	420	M20 X 2.5	280	205	440	325	610	450
7/8" - 9	225	165	585	430	820	605	M20 X 1.5	310	230	650	480	900	665
7/8" - 14	250	185	640	475	905	670	M24 X 3	480	355	760	560	1050	780
1" - 8	340	250	875	645	1230	910	M24 X 2	525	390	830	610	1150	845
1" - 12	370	275	955	705	1350	995	M30 X 3.5	960	705	1510	1120	2100	1550
1-1/8" - 7	480	355	1080	795	1750	1290	M30 X 2	1060	785	1680	1240	2320	1710
1 1/8" - 12	540	395	1210	890	1960	1440	M36 X 3.5	1730	1270	2650	1950	3660	2700
1 1/4" - 7	680	500	1520	1120	2460	1820	M36 X 2	1880	1380	2960	2190	4100	3220
1 1/4" - 12	750	555	1680	1240	2730	2010							
1 3/8" - 6	890	655	1990	1470	3230	2380							
1 3/8" - 12	1010	745	2270	1670	3680	2710							
1 1/2" - 6	1180	870	2640	1950	4290	3160							
1 1/2" - 12	1330	980	2970	2190	4820	3560							

<sup>1</sup> in-tpi = nominal thread dia .in inches-threads per inch

<sup>2</sup> N · m = newton-meters

<sup>3</sup> ft-lb= foot pounds

<sup>4</sup> mm x pitch = nominal thread dia. in millimeters x thread pitch

Torque tolerance + 0%, -15% of torquing values. Unless otherwise specified use torque values listed above.



## Warranty

**Land Pride** warrants to the original purchaser that this Land Pride product will be free from defects in material and workmanship for a period of one year, from the date of delivery to the end user, when used as intended and under normal service and conditions for personal use; and 6 months for municipalities, golf courses, sod farms and rental purposes. All Multi-spindle Rotary Cutters carry a 3 year gearbox warranty, all Post Hole Digger gearboxes carry a 5 year warranty. This Warranty is limited to the replacement of any defective part by Land Pride and the installation by the dealer of any such replacement part and does not cover common wear items such as blades, belts, tines, etc. Land Pride reserves the right to inspect any equipment or parts which are claimed to have been defective in material or workmanship.

This Warranty does not apply to any part or product which in Land Pride's judgement shall have been misused or damaged by accident or lack of normal maintenance or care, or which has been repaired or altered in a way which adversely affects its performance or reliability, or which has been used for a purpose for which the product is not designed. Misuse also specifically includes failure to properly maintain oil levels, grease points and driveline shafts.

Claims under this Warranty must be made to the dealer which originally sold the product and all warranty adjustments must be made through such dealer. Land Pride reserves the right to make changes in materials or design of the product at any time without notice.

This Warranty shall not be interpreted to render Land Pride liable for damages of any kind, direct, consequential, or contingent, to property. Furthermore, Land Pride shall not be liable for damages resulting from any cause beyond its reasonable control. This Warranty does not extend to loss of crops, losses caused by harvest delays or any expense or loss for labor, supplies, rental machinery or for any other reason.

**No other warranty of any kind whatsoever, express or implied, is made with respect to this sale; and all implied warranties of merchantability and fitness for a particular purpose which exceed the obligations set forth in this written warranty are hereby disclaimed and excluded from this sale.**

This Warranty is not valid unless registered with Land Pride within 10 days from the date of delivery to the end user.

---

**Great Plains Manufacturing, Inc.**

Corporate Office: PO. Box 5060  
Salina, Kansas 67402-5060 USA

## Free Manuals Download Website

<http://myh66.com>

<http://usermanuals.us>

<http://www.somanuals.com>

<http://www.4manuals.cc>

<http://www.manual-lib.com>

<http://www.404manual.com>

<http://www.luxmanual.com>

<http://aubethermostatmanual.com>

Golf course search by state

<http://golfingnear.com>

Email search by domain

<http://emailbydomain.com>

Auto manuals search

<http://auto.somanuals.com>

TV manuals search

<http://tv.somanuals.com>