

**All Flex Mowers**

**AFM4214 Series**

Description	Specification / Capacity	Description	Specification / Capacity
Discharge Type	Rear		
Cutting Width	14'-0"	Blade Drive Belt	1 B-Section
Overall Width	14'-3"	Drive Belt Tension	Spring Loaded Idler with Overcenter Release
Transport Height	7'-7 1/2"	Blade Bearing	Sealed Ball Bearings
Transport Width	6' - 8"	Blades 3 Each Per Deck	Low Lift (5/16" x 2 1/2" x 20 29/32") Optional Blades: Medium Lift, High Lift & Mulching
Overall Length	14'-10" Mowing Position 12'-11" Transport Position	Blade Overlap	1 1/4"
Machine Weight	W/15" tires = 3,000 lbs. W/18" tires = 3,150 lbs.	Blade Spindle Speed	3,362 R.P.M.
Tractor Horsepower	Minimum 40 HP / Maximum 70 HP	Blade Tip Speed	18,396 F.P.M.
Hitch	Pull Type with Adjustable Clevis and Safety Tow Chain	Deck Tires	10 each, Air tires with Sealant 18 x 9.5 or 15 x 6.6
Tongue Support	2,200 lb. Capacity Screw Jack	Deck Wheel Spindles	1 1/4" w/Nylon Bushings
Gearbox Support	3/8" Steel Channel	Transport Tires	2 each, 23 x 10.5 with Sealant
Gearboxes	540 RPM (1)-Splitter & (3)-Wing	Transport Locks	Automatic with Pull Rope Release
Main Driveline (1)	Cat. IV Constant Velocity with Slip Clutch when wings are conventional	Wing Deck Flex	23 Degrees Left To Right 22 Degrees Front To Back
Deck Drivelines (3)	Cat. II with or without Slip Clutch	Center Deck Flex	10 Degrees Left To Right 22 Degrees Front To Back
Cutting Height	3/4" to 5 1/4" (In 1/4" increments)	Hydraulic Outlets	1 Set Required
Deck Size & Quantity	3 each / 60"	Deck Cylinders	Dual Acting
Deck Overlap	6"	Gauge Wheel Arms	1/4" Wall Square Tubing
Deck Thickness	3/16"	Turning Radius	Zero Turning Radius
Anti-Scalp Roller	Front Center and Outside Deck Corners	Mowing Capacity @ 2 mph @ 4 mph @ 6 mph	3.39 Acres Per Hour 6.78 Acres Per Hour 10.17 Acres Per Hour

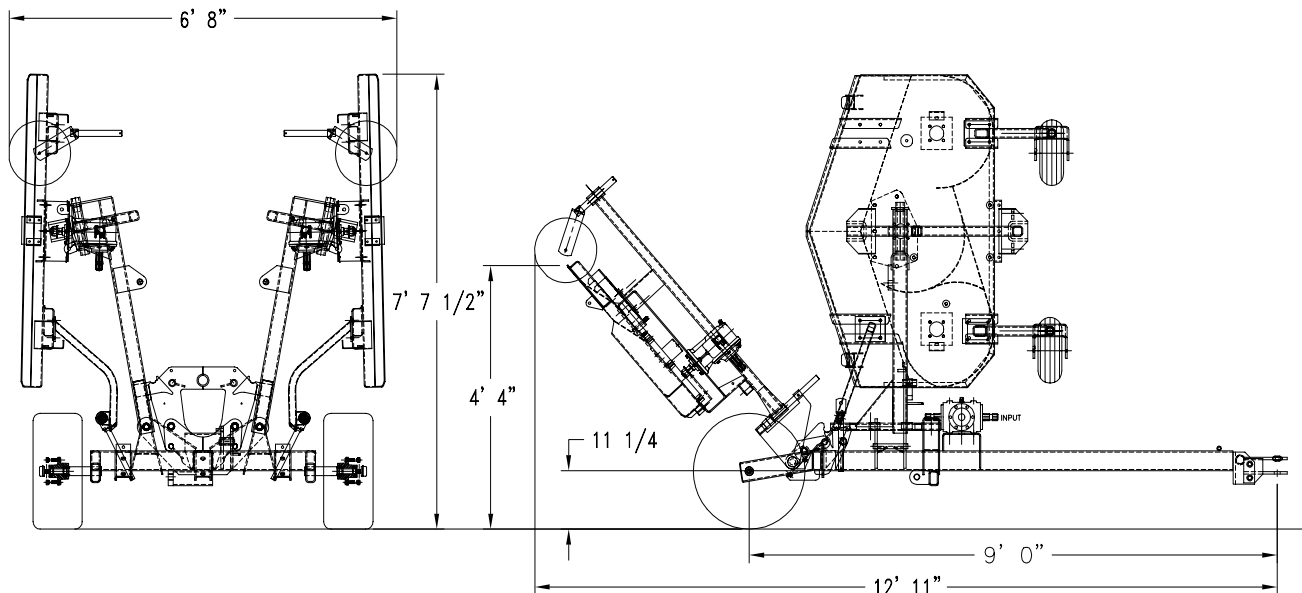

*Designs, specifications, features and i*

**Model 4214 Specification Drawing**

**e.**

14043

All Flex Mowers

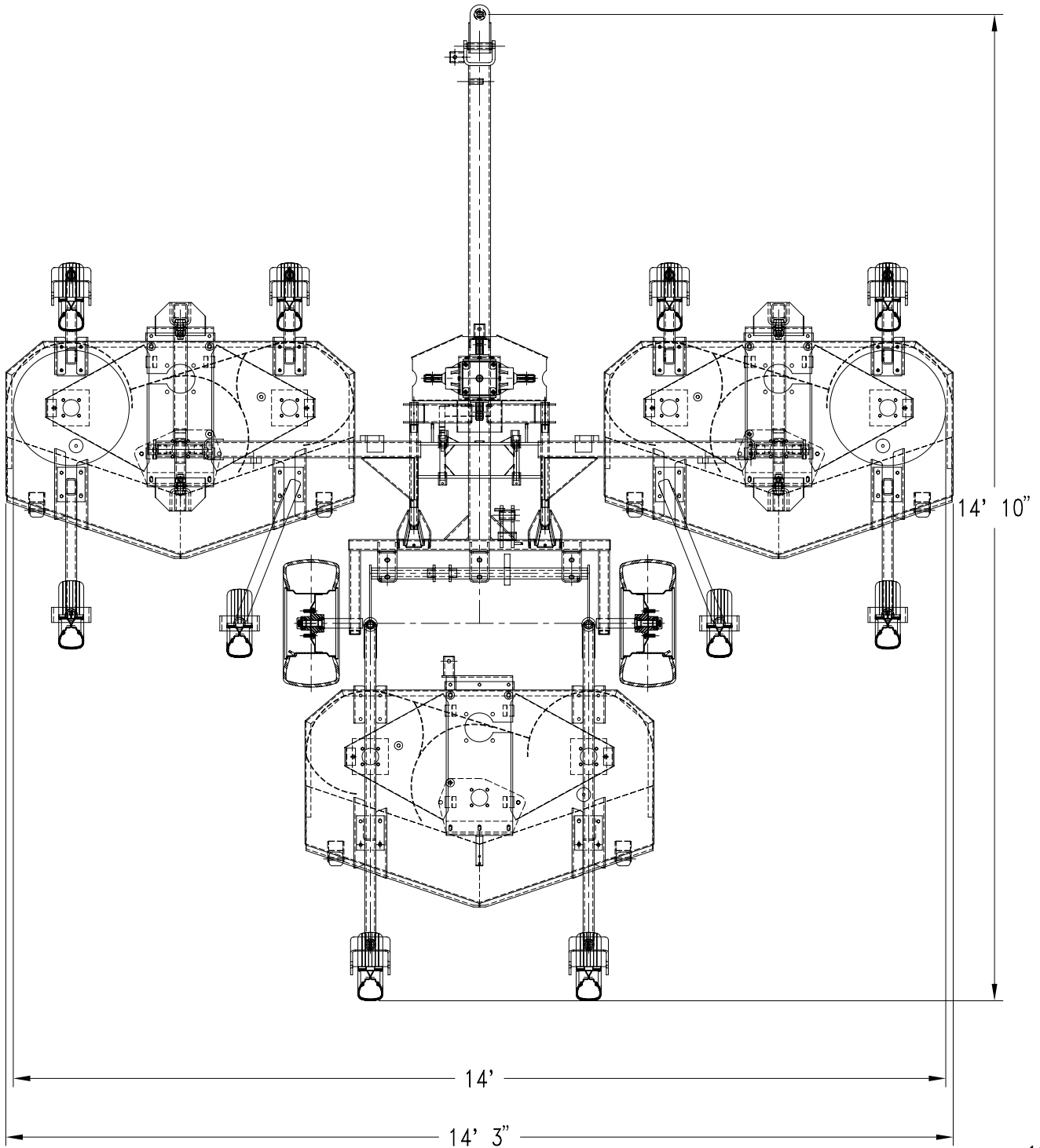

Model 4214 Specification Drawing

Designs, specifications, features and information are subject to change without notice.

## All Flex Mowers

### AFM4216 Series

Description	Specification / Capacity	Description	Specification / Capacity
Discharge Type	Rear		
Cutting Width	16'- 8"	Blade Drive Belt	1 B-Section
Overall Width	16' -10"	Drive Belt Tension	Spring Loaded Idler with Overcenter Release
Transport Height	8' -10"	Blade Bearing	Sealed Ball Bearings
Transport Width	6'- 8" With Lock Pins Installed	Blades 3 Each Per Deck	Low Lift (5/16" x 2 1/2" x 25") Optional Blades: Medium Lift, High Lift & Mulching
Overall Length	15'-0" Mowing Position 13'-4" Transport Position	Blade Overlap	1 1/4"
Machine Weight	W/15" tires = 3,315 lbs. W/18" tires = 3,465 lbs.	Blade Spindle Speed	2,302 R.P.M.
Tractor Horsepower	Minimum 40 HP / Maximum 70 HP	Blade Tip Speed	18,340 F.P.M.
Hitch	Pull Type with Adjustable Clevis and Safety Tow Chain	Deck Tires	10 each, Air tires with Sealant 18 x 9.5 or 15 x 6.6
Tongue Support	2,200 lb. Capacity Screw Jack	Deck Wheel Spindles	1 1/4" w/Nylon Bushings
Gearbox Support	3/8" Steel Channel	Transport Tires	2 each, 23 x 10.5 with Sealant
Gearboxes	540 RPM (1)-Splitter & (3)-Wing	Transport Locks	Automatic with Pull Rope Release
Main Driveline (1)	Cat. IV Constant Velocity with Slip Clutch when wings are conventional	Wing Deck Flex	23 Degrees Left To Right 22 Degrees Front To Back
Deck Drivelines (3)	Cat. II with or without Slip Clutch	Center Deck Flex	10 Degrees Left To Right 22 Degrees Front To Back
Cutting Height	3/4" to 5 1/4" (In 1/4" increments)	Hydraulic Outlets	1 Set Required
Deck Size & Quantity	3 each / 72"	Deck Cylinders	Dual Acting
Deck Overlap	8"	Gauge Wheel Arms	1/4" Wall Square Tubing
Deck Thickness	3/16"	Turning Radius	Zero Turning Radius
Anti-Scalp Roller	Front Center and Outside Deck Corners	Mowing Capacity @ 2 mph @ 4 mph @ 6 mph	4.0 Acres Per Hour 8.1 Acres Per Hour 12.1 Acres Per Hour

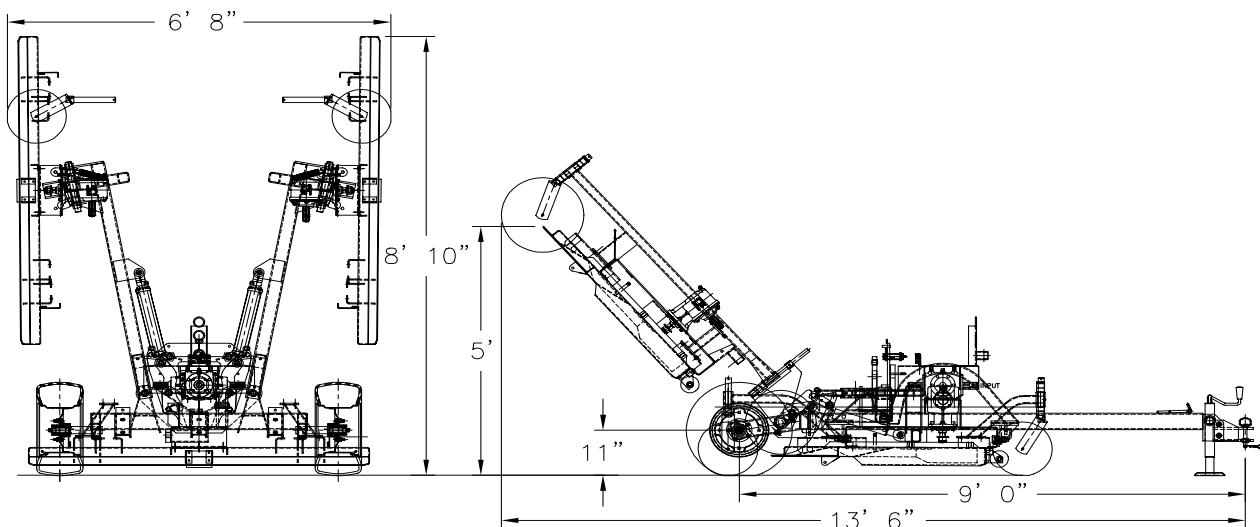

Model 4216 Specification Drawing

Designs, specifications, features and information are subject to change without notice.

17853

All Flex Mowers

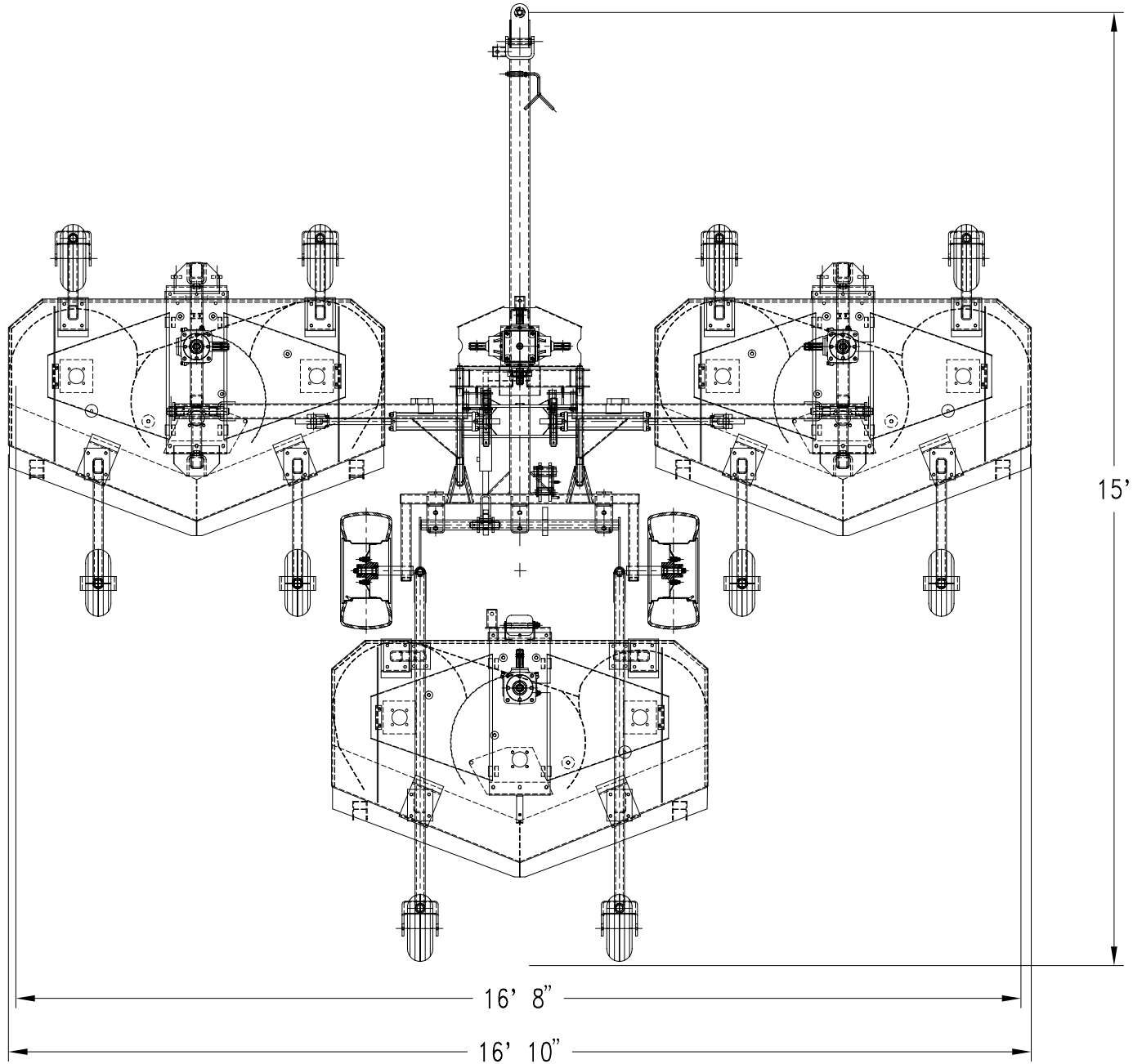

Model 4216 Specification Drawing

13665

Designs, specifications, features and information are subject to change without notice.

## Free Manuals Download Website

<http://myh66.com>

<http://usermanuals.us>

<http://www.somanuals.com>

<http://www.4manuals.cc>

<http://www.manual-lib.com>

<http://www.404manual.com>

<http://www.luxmanual.com>

<http://aubethermostatmanual.com>

Golf course search by state

<http://golfingnear.com>

Email search by domain

<http://emailbydomain.com>

Auto manuals search

<http://auto.somanuals.com>

TV manuals search

<http://tv.somanuals.com>