

Rotary Tillers

RTA10 & RTA15 Series

RTA1042, RTA1050 & RTA1058

RTA1550 & RTA1558

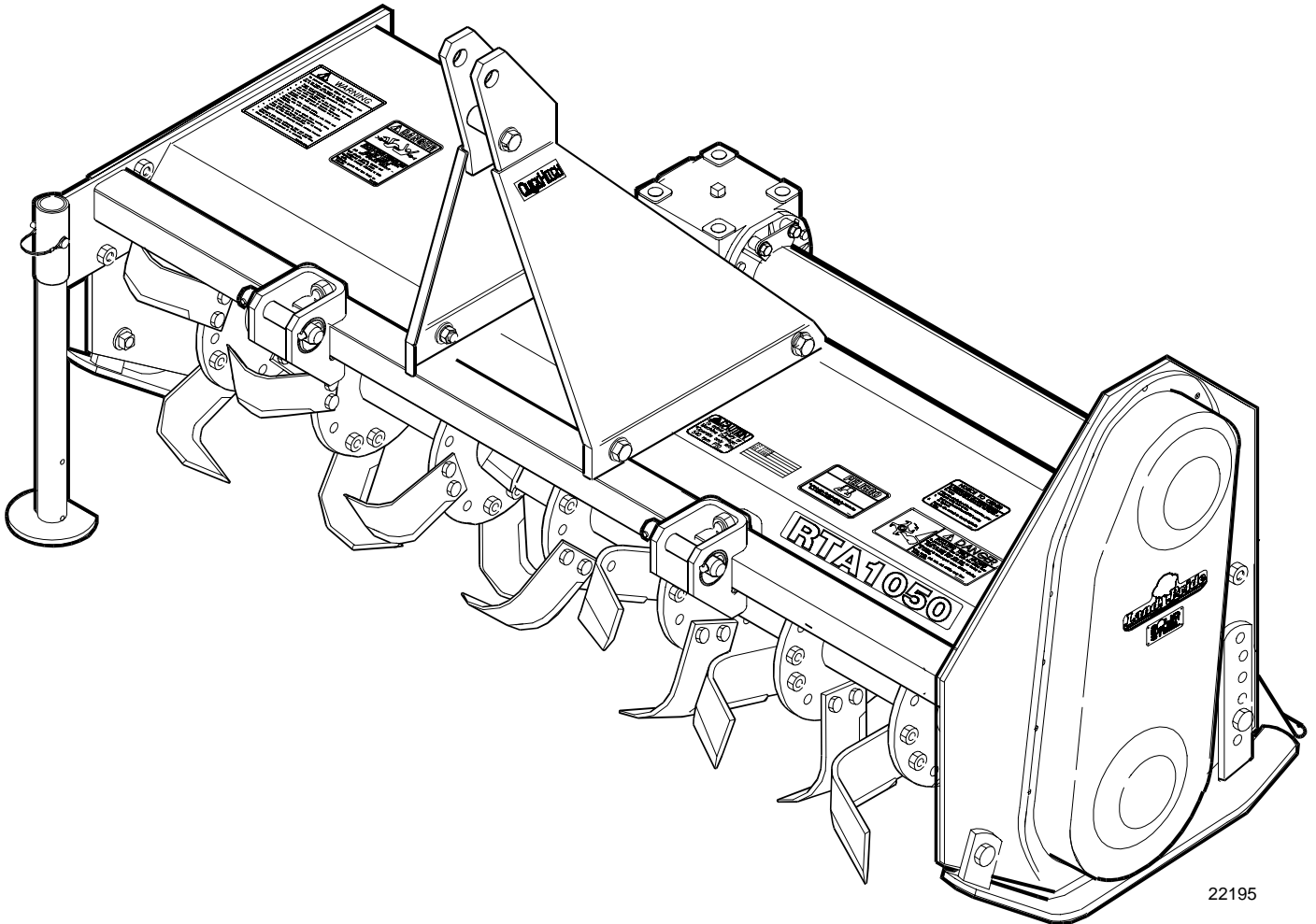

22195

311-252M Operator's Manual



Read the Operator's manual entirely. When you see this symbol, the subsequent instructions and warnings are serious - follow without exception. Your life and the lives of others depend on it!

© Copyright 2008 Printed 10/13/08

Cover photo may show optional equipment not supplied with standard unit.



Important Safety Information	1	Section 4 Maintenance and Lubrication .17	
Safety at All Times	1	Maintenance	17
Look For The Safety Alert Symbol	1	Tine Replacement	17
Safety Labels	4	Driveline Protection	17
Introduction	7	Clutches With 4 Adjusting Nuts	17
Application	7	Clutch Run-In	17
Using This Manual	7	Clutch Disassembly & Assembly	18
Owner Assistance	7	Clutches With 8 Hex Socket Bolts	19
Section 1 Assembly and Set-Up	8	Clutch Run-In	19
Tractor Requirements	8	Clutch Disassembly & Assembly	19
Hitch, Driveline Guard & Rear Chain	8	Shearbolt Protection	19
Leg Stand Assembly	9	Storage	20
Tractor Hook-Up	9	Lubrication	21
Driveline Installation	10	Driveline U-Joint	21
Checking Driveline Minimum Length	10	Driveline Shaft	21
Checking Driveline Maximum Length	11	Chaincase	21
Section 2 Operating	12	Bearing On Right End Of Rotor Shaft	22
General Notes for Field Operations	12	Side Plug Gearbox	22
Operating Check List	12	Top Plug Gearbox (10 Series)	22
Transporting	12	Top Plug Gearbox (15 Series)	22
Parking	13	Section 5 Specifications and Capacities 23	
Operating Instructions	13	RTA10 Series Rotary Tiller	23
Section 3 Adjustments	14	RTA15 Series Rotary Tiller	23
RTA10 Tiller Hitch Offset	14	Section 6 Features and Benefits	24
RTA15 Tiller Hitch Sideshift	14	RTA10 Series Rotary Tiller	24
Drive Chain	15	RTA15 Series Rotary Tiller	25
Rear Deflector	15	Section 7 Troubleshooting	26
Skid Shoe	16	Section 8 Appendix	27
		Torque Values Chart	27
		Notes	28
		Warranty	29

© Copyright 2008 All rights Reserved

Land Pride provides this publication "as is" without warranty of any kind, either expressed or implied. While every precaution has been taken in the preparation of this manual, Land Pride assumes no responsibility for errors or omissions. Neither is any liability assumed for damages resulting from the use of the information contained herein. Land Pride reserves the right to revise and improve its products as it sees fit. This publication describes the state of this product at the time of its publication, and may not reflect the product in the future. The illustrations in this manual are not intended for safe and proper assembly or disassembly of equipment. The illustrations are intended for ordering parts only.

Land Pride is a registered trademark.

All other brands and product names are trademarks or registered trademarks of their respective holders.

Printed in the United States of America.

Important Safety Information

These are common practices that may or may not be applicable to the products described in this manual.

Safety at All Times

Thoroughly read and understand the instructions given in this manual before operation. Refer to the "Safety Label" section, read all instructions noted on them.

Do not allow anyone to operate this equipment who has not fully read and comprehended this manual and who has not been properly trained in the safe operation of the equipment.

- ▲ Operator should be familiar with all functions of the unit.
- ▲ Operate implement from the driver's seat only.
- ▲ Make sure all guards and shields are in place and secured before operating the implement.
- ▲ Do not leave tractor or implement unattended with engine running.
- ▲ Dismounting from a moving tractor could cause serious injury or death.
- ▲ Do not stand between the tractor and implement during hitching.
- ▲ Keep hands, feet, and clothing away from power-driven parts.
- ▲ Wear snug fitting clothing to avoid entanglement with moving parts.
- ▲ Watch out for wires, trees, etc., when raising implement. Make sure all persons are clear of working area.
- ▲ Turning tractor too tight may cause implement to ride up on wheels. This could result in injury or equipment damage.

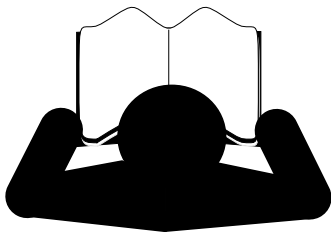

Look For The Safety Alert Symbol

The SAFETY ALERT SYMBOL indicates there is a potential hazard to personal safety involved and extra safety precaution must be taken. When you see this symbol, be alert and carefully read the message that follows it. In addition to design and configuration of equipment, hazard control and accident prevention are dependent upon the awareness, concern, prudence and proper training of personnel involved in the operation, transport, maintenance and storage of equipment.

Be Aware of Signal Words

A Signal word designates a degree or level of hazard seriousness. The signal words are:

DANGER

Indicates an imminently hazardous situation which, if not avoided, will result in death or serious injury. This signal word is limited to the most extreme situations, typically for machine components that, for functional purposes, cannot be guarded.

WARNING

Indicates a potentially hazardous situation which, if not avoided, could result in death or serious injury, and includes hazards that are exposed when guards are removed. It may also be used to alert against unsafe practices.

CAUTION

Indicates a potentially hazardous situation which, if not avoided, may result in minor or moderate injury. It may also be used to alert against unsafe practices.

For Your Protection

- ▲ Thoroughly read and understand the "Safety Label" section, read all instructions noted on them.

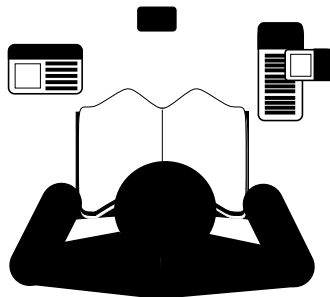

Shutdown and Storage

- ▲ Lower machine to ground, put tractor in park, turn off engine, and remove the key.
- ▲ Detach and store implements in a area where children normally do not play. Secure implement by using blocks and supports.

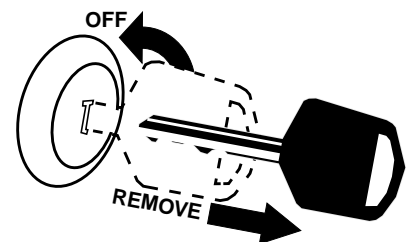

Important Safety Information

These are common practices that may or may not be applicable to the products described in this manual.

Use Safety Lights and Devices

- ▲ Slow moving tractors, self-propelled equipment, and towed implements can create a hazard when driven on public roads. They are difficult to see, especially at night.
- ▲ Flashing warning lights and turn signals are recommended whenever driving on public roads. Use lights and devices provided with implement.

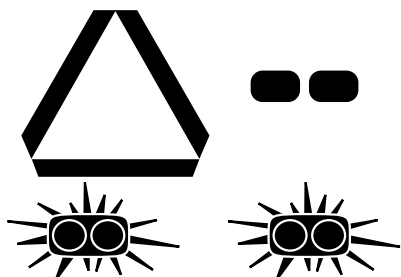

Transport Machinery Safely

- ▲ Comply with state and local laws.
- ▲ Maximum transport speed for implement is 20 mph. **DO NOT EXCEED.** Never travel at a speed which does not allow adequate control of steering and stopping. Some rough terrain require a slower speed.
- ▲ Sudden braking can cause a towed load to swerve and upset.

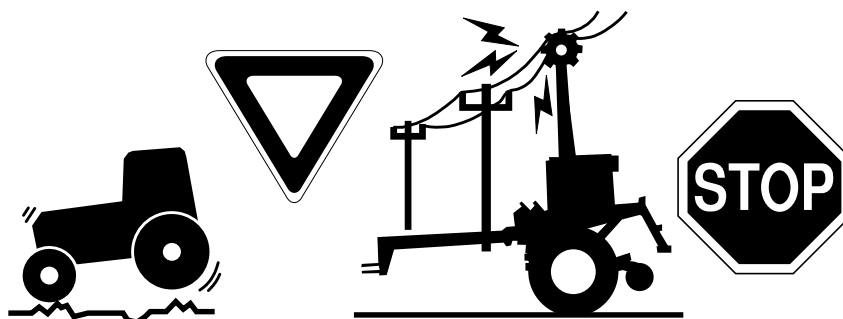

Reduce speed if towed load is not equipped with brakes.

- ▲ Use the following maximum speed - tow load weight ratios as a guideline:

20 mph when weight is less than or equal to the weight of tractor.

10 mph when weight is double the weight of tractor.

- ▲ **IMPORTANT:** Do not tow a load that is more than double the weight of tractor.

Practice Safe Maintenance

- ▲ Understand procedure before doing work. Use proper tools and equipment, refer to Operator's Manual for additional information.
- ▲ Work in a clean dry area.
- ▲ Lower the implement to the ground, put tractor in park, turn off engine, and remove key before performing maintenance.

- ▲ Allow implement to cool completely.
- ▲ Do not grease or oil implement while it is in operation.
- ▲ Inspect all parts. Make sure parts are in good condition & installed properly.
- ▲ Remove buildup of grease, oil or debris.
- ▲ Remove all tools and unused parts from implement before operation.



Keep Riders Off Machinery

- ▲ Riders obstruct the operator's view, they could be struck by foreign objects or thrown from the machine.
- ▲ Never allow children to operate equipment.

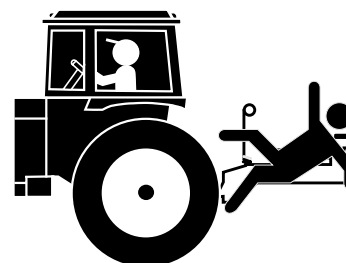

Important Safety Information

These are common practices that may or may not be applicable to the products described in this manual.

Prepare for Emergencies

- ▲ Be prepared if a fire starts.
- ▲ Keep a first aid kit and fire extinguisher handy.
- ▲ Keep emergency numbers for doctor, ambulance, hospital and fire department near phone.

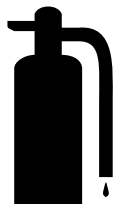
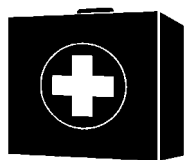
**Wear Protective Equipment**

- ▲ Protective clothing and equipment should be worn.
- ▲ Wear clothing and equipment appropriate for the job. Avoid loose fitting clothing.
- ▲ Prolonged exposure to loud noise can cause hearing impairment or hearing loss. Wear suitable hearing protection such as earmuffs or earplugs.
- ▲ Operating equipment safely requires the full attention of the operator. Avoid wearing radio headphones while operating machinery.

**Avoid High Pressure Fluids Hazard**

- ▲ Escaping fluid under pressure can penetrate the skin causing serious injury.
- ▲ Avoid the hazard by relieving pressure before disconnecting hydraulic lines or performing work on the system.
- ▲ Make sure all hydraulic fluid connections are tight and all hydraulic hoses and lines are in good condition before applying pressure to the system.
- ▲ Use a piece of paper or cardboard, NOT BODY PARTS, to check for suspected leaks.
- ▲ Wear protective gloves and safety glasses or goggles when working with hydraulic systems.
- ▲ If an accident occurs, see a doctor immediately. Any fluid injected into the skin must be treated within a few hours or gangrene may result.

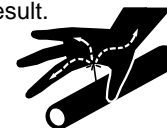

Important Safety Information

Safety Labels

1. Your tiller comes equipped with all safety labels in place. They were designed to help you safely operate your mower. Read and follow their directions.
2. Keep all safety labels clean and legible.
3. Replace all damaged or missing labels. To order new labels go to your nearest Land Pride dealer.
4. Some new equipment installed during repair requires safety labels to be affixed to the replaced component as specified by Land Pride. When ordering new components make sure the correct safety labels are included in the request.

5. Refer to this section for proper label placement. To install new labels:
 - a. Clean the area the label is to be placed.
 - b. Spray soapy water on the surface where the label is to be placed.
 - c. Peel backing from label. Press firmly onto the surface.
 - d. Squeeze out air bubbles with the edge of a credit card.

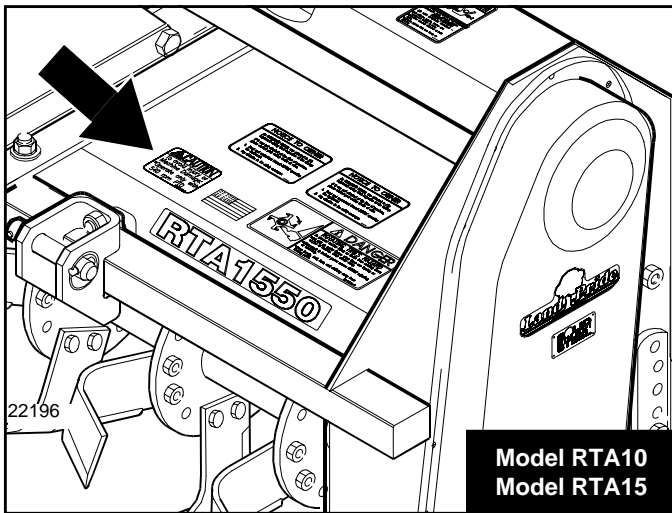

818-130C

Operate only w/540 rpm PTO

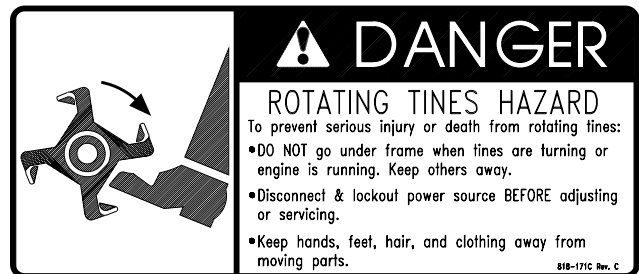
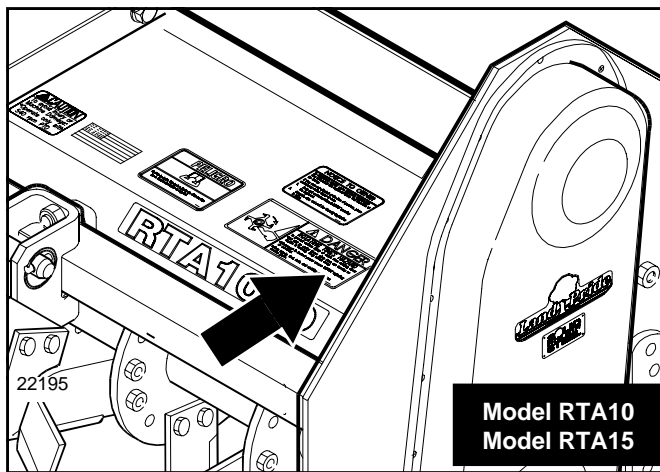

818-171C

Rotating Tines Hazard!

Important Safety Information

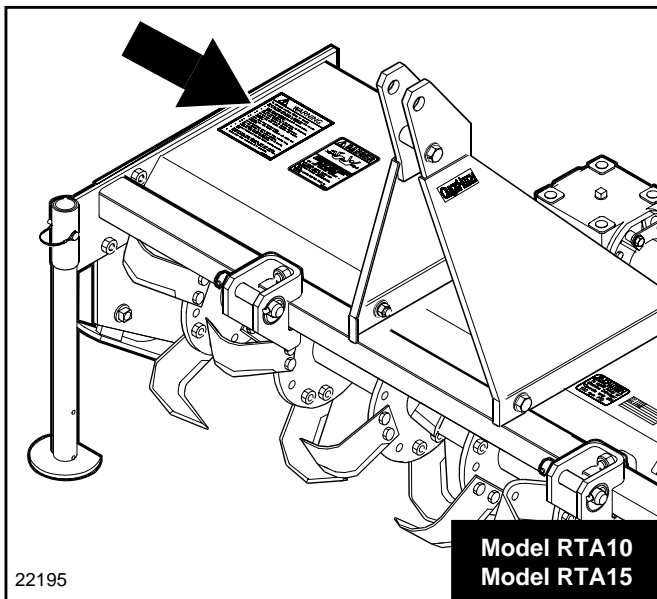
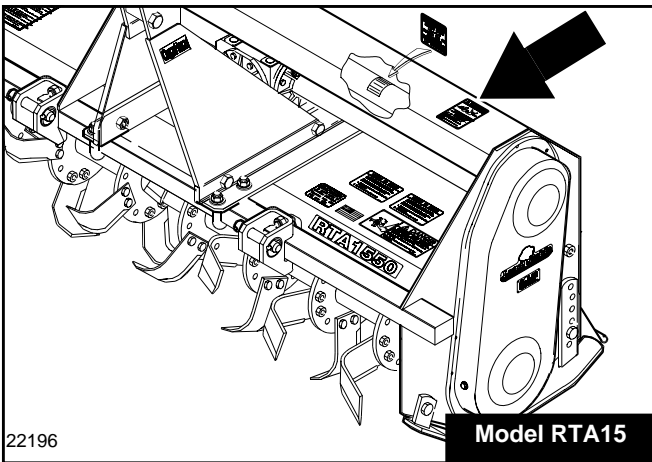
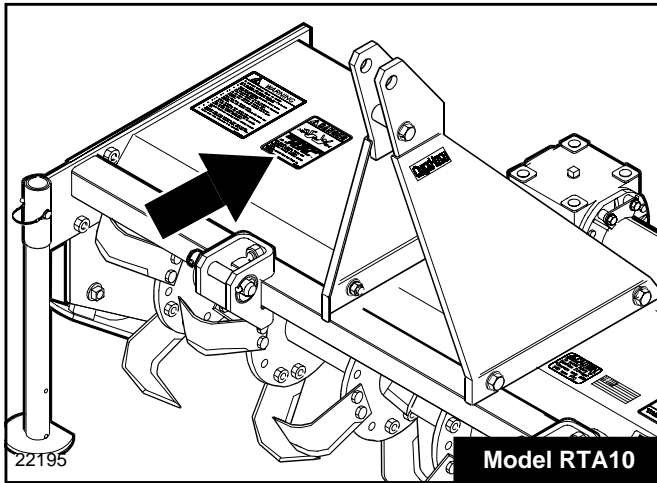

! DANGER

**ROTATING DRIVELINE
CONTACT CAN CAUSE DEATH
KEEP AWAY!**

DO NOT OPERATE WITHOUT –

- All driveline guards, tractor and equipment shields in place
- Drivelines securely attached at both ends.
- Driveline guards that turn freely on Driveline

818-552C

818-552C

Rotating Driveline Hazard - Keep Away!

! WARNING

To prevent serious injury or death:

- * Read and understand Operator's Manual before using. Review annually.
- * Do not permit riders on the tractor or implement. Never carry children on tractor seat.
- * Do not allow children to operate implement.
- * Operate only with guards installed and in good condition.
- * Keep away from moving parts.
- * Operate only with tractor equipped with ROPS and seatbelts.
- * Before operating, clear debris from working area.
- * Do not operate in the raised position.
- * Stop engine, set brake and wait for all moving parts to stop before dismounting.
- * Support implement securely before working beneath unit.
- * Transport with clean reflectors, SMV and working lights as required by federal, state, and local laws.
- * Stand clear when implement is in operation.

Si no lee ingles, pida ayuda a alguien que si lo lea para que le traduzca las medidas de seguridad.

818-858C REV.B

818-858C

General Safety Instructions

Important Safety Information

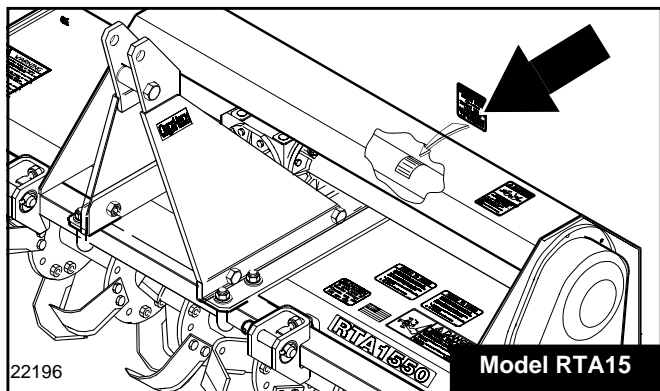
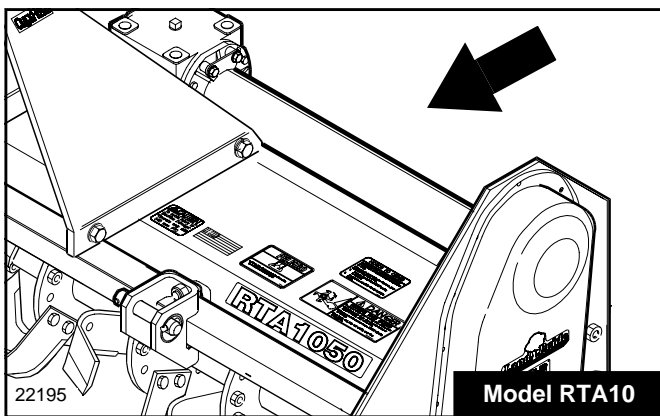

818-543C

Guard Missing - Do Not operate.

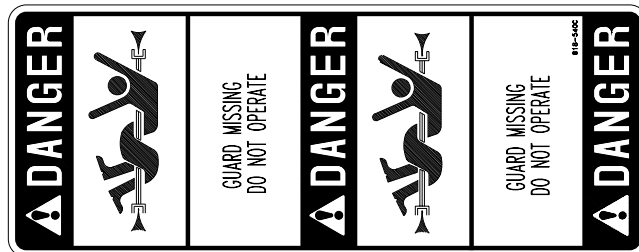
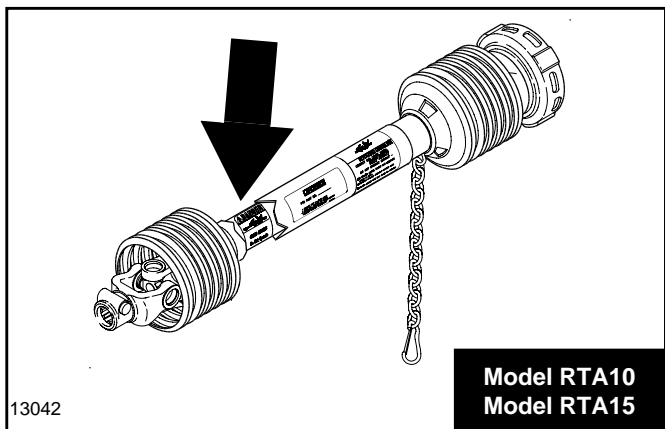

818-540C

Shield missing - Do Not operate.

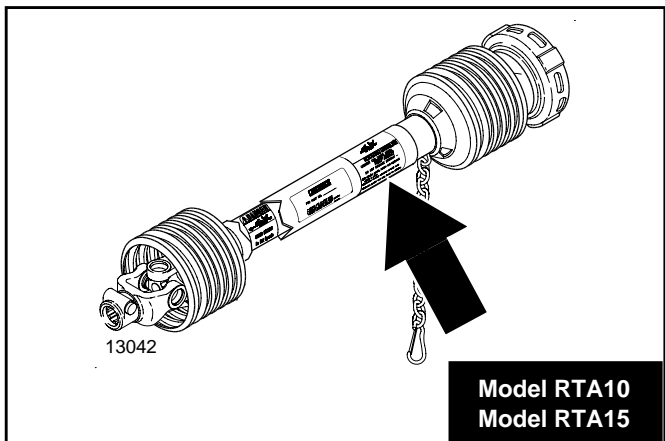

818-552C

Rotating Driveline Hazard - Keep Away!

Introduction

Land Pride welcomes you to the growing family of new product owners.

This rotary tiller has been designed with care and built by skilled workers using quality materials. Proper assembly, maintenance, and safe operating practices will help you get years of satisfactory use from the machine.

Application

The RTA10 and RTA15 Series Rotary Tillers are designed and built by Land Pride to till the soil for seedbed or planting preparation. Both models are adapted for three-point hitch Category 1 mounting. The RTA10 has a 17-25 horsepower tractor requirement, while the RTA15 has a 17-35 horsepower requirement. These Land Pride Tillers have uses and applications in landscaping, nurseries, gardens, and light commercial use. See “**Features and Benefits**”, “**Section 6**” for additional information.

Using This Manual

- This Operator’s Manual is designed to help familiarize you with safety, assembly, operation, adjustments, troubleshooting, and maintenance. Read this manual and follow the recommendations to help ensure safe and efficient operation.
- The information contained within this manual was current at the time of printing. Some parts may change slightly to assure you of the best performance.
- To order a new Operator’s or Parts Manual contact your authorized dealer. Manuals can also be downloaded, free-of-charge from our website at www.landpride.com or printed from the Land Pride Service & Support Center by your dealer.

Terminology

“Right” or “Left” as used in this manual is determined by facing forward in the direction the machine will operate while in use unless otherwise stated.

Definitions

NOTE: A special point of information that the operator must be aware of before continuing.

IMPORTANT: A special point of information related to its preceding topic. Land Pride’s intention is that this information should be read and noted before continuing.

Owner Assistance

The Warranty Registration card should be filled out by the dealer at the time of purchase. This information is necessary to provide you with quality customer service.

If customer service or repair parts are required contact a Land Pride dealer. A dealer has trained personnel, repair parts and equipment needed to service the tiller.

The parts on your Rotary Tiller have been specially designed and should only be replaced with genuine Land Pride parts. Therefore, should your tiller require replacement parts go to your Land Pride Dealer.

Serial Number Plate

For prompt service always use the serial number and model number when ordering parts from your Land Pride dealer. Be sure to include your serial and model numbers in correspondence also. Refer to Figure 1 for the location of your serial number plate.

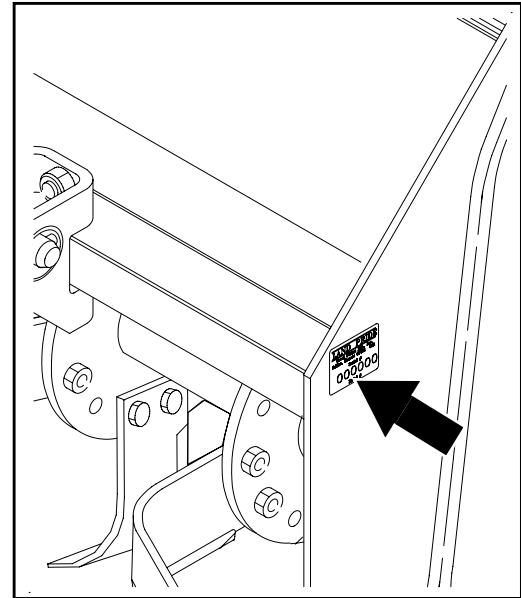

Serial Number Plate Location

Figure 1

Further Assistance

Your dealer wants you to be satisfied with your new Rotary Tiller. If for any reason you do not understand any part of this manual or are not satisfied with the service received, the following actions are suggested:

1. Discuss the matter with your dealership service manager making sure he is aware of any problems you may have and that he has had the opportunity to assist you.
2. If you are still not satisfied, seek out the owner or general manager of the dealership, explain the problem and request assistance.
3. For further assistance write to:

Land Pride Service Department
1525 East North Street
 P.O. Box 5060
 Salina, Ks. 67402-5060

E-mail address
lp servicedept@landpride.com

Section 1 Assembly and Set-Up

CAUTION

To avoid bodily injury caused by accidental falling of tiller, securely support tiller on safe supporting stands or blocks!

This unit is shipped almost completely assembled. Carefully follow instructions for final assembly.

Before attempting assembly check the following items. Having all the needed parts and equipment readily at hand will speed up your assembly task and will make the job as safe as possible.

- Check for fasteners and pins that were shipped with the tiller. All hardware coming from the factory has been installed in the location where it will be used. If a part or fastener is temporarily removed for assembly reasons, remember where it goes. Keep the parts separated.
- Have a fork lift or loader along with chains and safety stands that are sized for the job ready for the assembly task.
- Have a minimum of 2 people at hand during assembly.
- Check to see that all nuts are tightened.

NOTE: For correct torque values, refer to "Torque Values Chart" on page 27.

Tractor Requirements

This tiller is designed with a 3-point category I hitch. Horse power rating of the tractor should not exceed 25 PTO horsepower for the 10 Series Rotary Tiller and not to exceed 35 PTO horsepower for the 15 Series.

CAUTION

Do not over speed PTO or machine damage may result. This tiller is designed to be used with a tractor using a 540 rpm rear PTO.

NOTE: In order to maintain steering control, ballast may have to be added to your tractor. To determine whether or not to add ballast, refer to your tractor operator's manual.

Hitch, Driveline Guard & Rear Chain

Refer to Figure 1-1:

1. Install top 3-point hitch plates (#6 & #7) outside of gearbox mounting frame with 5/8" x 1 1/2" bolts (#3), 5/8" lockwashers (#4), and 5/8" nuts (#5). Do not tighten hardware at this time.
2. Install spacer (#9) between upper 3-point hitch plates (#6 & #7) with 5/8" x 3 1/2" long bolt (#8).
3. Securely tighten all bolts to the correct torque.

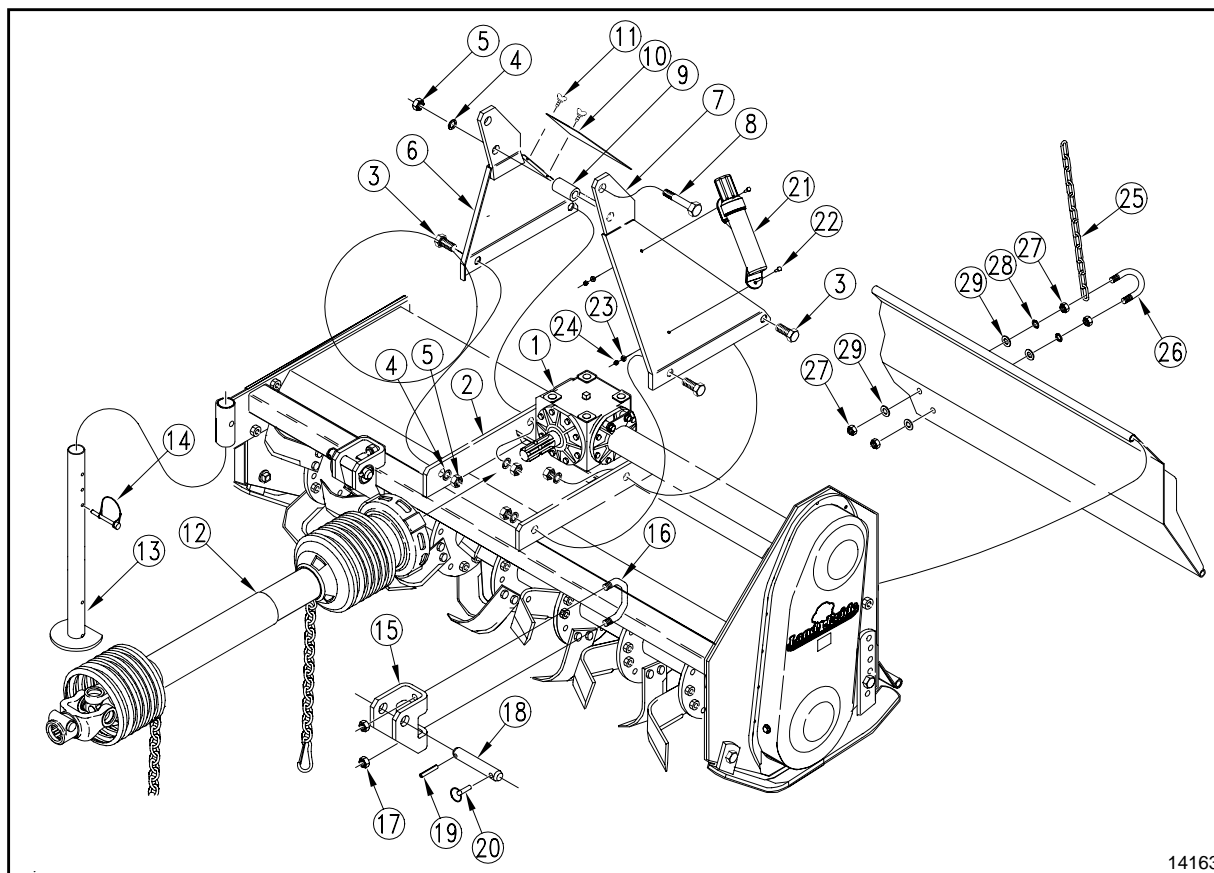

14163

**Assembly Illustration
Figure 1-1**

Section 1 Assembly and Set-Up

- Install driveline guard (#10) to the top of the 3-point hitch plates with four 1/4" wing screws (#11).

NOTE: Remove driveline guard for easier access to the driveline at the gearbox.

- Mount left hand clevis (#15) over square tube as shown. Make certain longer chamfer is positioned on the bottom.
- Locate u-bolt (#16) behind the square tube and insert through clevis (#15) holes as shown.
- Secure with 1/2"-13 hex nylock nuts (#17). Do not tighten nuts at this time.
- Drive 1/4" x 1 3/4" rollpin into pin (#19) into 1/4" hole into lower hitch pin (#18).
- Insert lower hitch pin into clevis and secure with linch pin (#20).
- Repeat step 5 through 9 for the right hand clevis.
- Position clevis 26 7/8" apart from inside of clevis plate to inside of clevis plate and center off the gearbox input shaft. When offsetting tiller to the right, see "RTA10 Tiller Hitch Offset" or "RTA15 Tiller Hitch Sideshift" on page 14.
- Tighten 1/2" nuts (#17) to the correct torque.
- Install manual tube (#21) to hitch plate (#7) with two 1/4"-20 x 1 GR5 hex head cap screws (#22), SAE flat washers (#23) and hex nylock nut (#24).
- Tighten 1/4" cap screws (#22) to the correct torque.
- Insert u-bolt (#26) through chain (#25).
- Install two 3/8" nuts (#27), two lock washers (#28) and flat washers (#29) onto the u-bolt an equal distance from the end.
- Insert u-bolt through deflector shield and secure with tow 3/8" flat washers (#29) and hex nuts (#27). Tighten nuts to the correct torque.
- Attach opposite end of chain to slot in tiller frame above.

Leg Stand Assembly

Refer to Figure 1-1:

- Insert leg stand (#13) into leg stand holder on the end of the tiller frame.
- Adjust to the desired height and pin with 1/4" x 1 3/4" long wire lock pin (#14).

IMPORTANT: The three upper holes are used for parking the tiller and the bottom hole is used when the tiller is in use.

Tractor Hook-Up

Refer to Figure 1-2:

- When using tractors with multi-speed PTO, be certain PTO is set for 540 rpm.
- Back tractor up to tiller until lower 3-Point links are aligned with hitch clevises on tiller.
- Secure the tractor's 3-Point lower links to the lower hitch clevises using 7/8" diameter hitch pins.
- Secure the tractor's top link to the tiller top hitch using a 3/4" diameter hitch pin (supplied by customer). Adjust tractor top link in order to level the tiller.
- Adjust the tractor's 3-Point hitch lift height so that the tiller tines are not lifted more than 14 inches off the ground to prevent damage to the driveline u-joints.



WARNING

Lifting unit more than 14" high while PTO is engaged may damage driveline components.

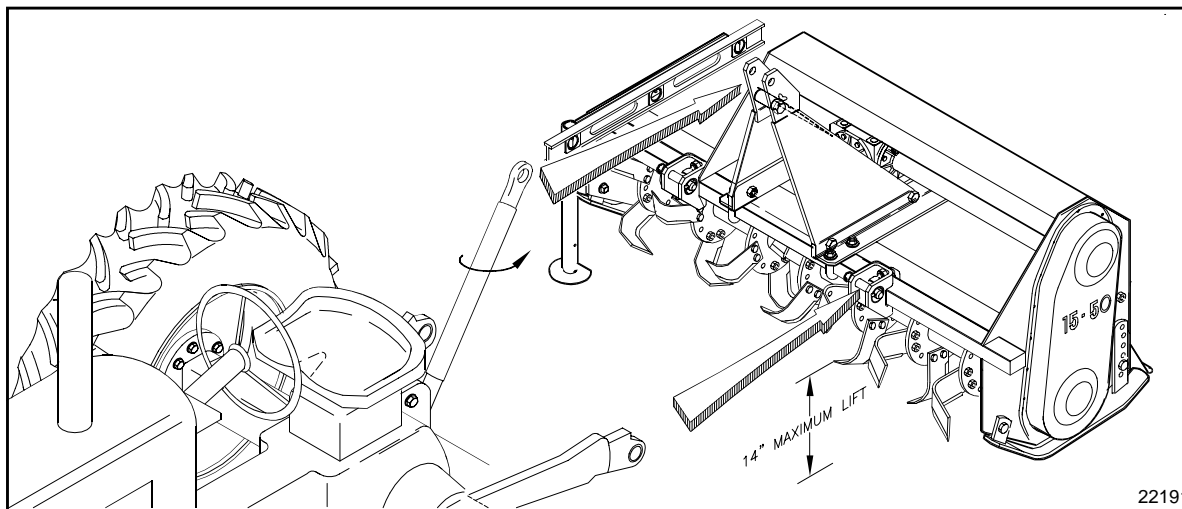

22191

Tractor Hook-Up
Figure 1-2

Section 1 Assembly and Set-Up

Driveline Installation

Refer to Figure 1-3, Figure 1-4 and Figure 1-5:

The tiller driveline is coupled to the tractor and implement shafts with either push pin couplers, pull collar couplers or a combination of both and with either a shear bolt or slip clutch on one end for protection from shock loads.

Always engage the PTO at low engine rpm to minimize start-up torque on the driveline. **Drivelines with friction clutches must go through a "run-in" operation prior to initial use and after long periods of inactivity.** See "Section 4 Maintenance and Lubrication" on page 17 for a detailed description of maintaining the driveline.

CAUTION

Tractor PTO shield and all tiller guards must be in place at all times during operation!

IMPORTANT: Always check driveline maximum and minimum length during initial setup, when connecting to a different tractor and when alternating between using a quick hitch and a standard 3-point hitch. More than one driveline may be required to fit all applications.

IMPORTANT: It is necessary to aligning the tractor's PTO shaft level with tiller's PTO shaft when checking to see if the driveline's minimum length is correct. Too long a driveline can damage the tractor, gearbox and driveline.

Checking Driveline Minimum Length

Refer to Figure 1-1 on page 8:

1. Start tractor and slowly engage tractor's hydraulic 3-point to lift the lower arms until the Rotary Tiller's driveline shaft is approximately level with tractor's PTO shaft.
2. Slide the slip clutch or shear bolt yoke end of driveline (#12) over the splined input shaft of gearbox (#1). Secure with driveline yoke locking device.

IMPORTANT: For easier access to gearbox input shaft, remove driveline guard (#10).

3. Slide the opposite driveline yoke end over the tractor's splined driveline shaft. Secure with driveline yoke locking device. Skip to step 4 if driveline fits between tractor and implement.

Refer to Figure 1-6 on page 11:

4. The driveline will require shortening if it is too long to fit between the tractor and tiller gearbox. Shorten driveline as follows:
 - a. Raise 3-point lower arms until tiller and tractor PTO shafts are approximately level with each other. Securely block Rotary Tiller frame in this position. Set tractor in park, shut tractor engine off, set park brake and remove switch key.

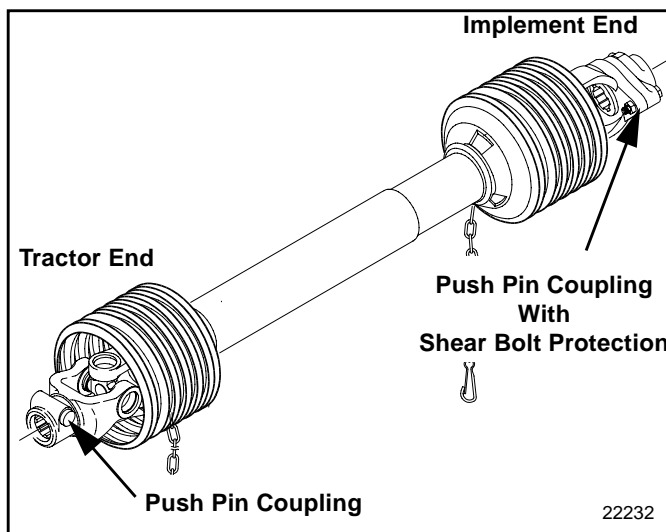

Figure 1-3

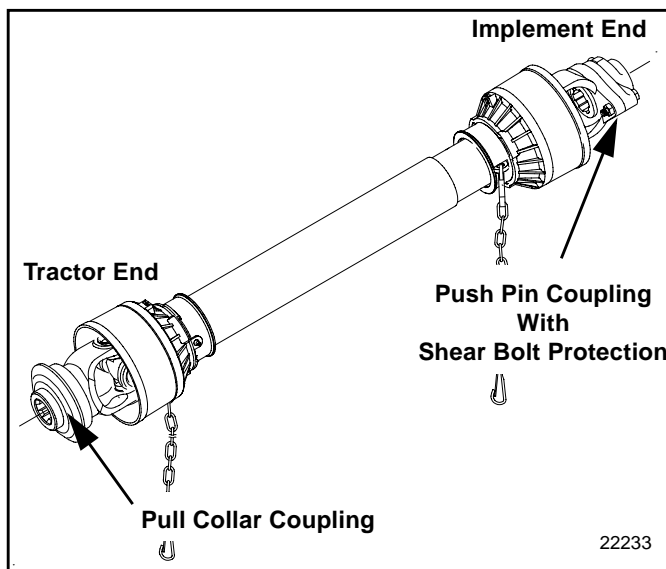

Figure 1-4

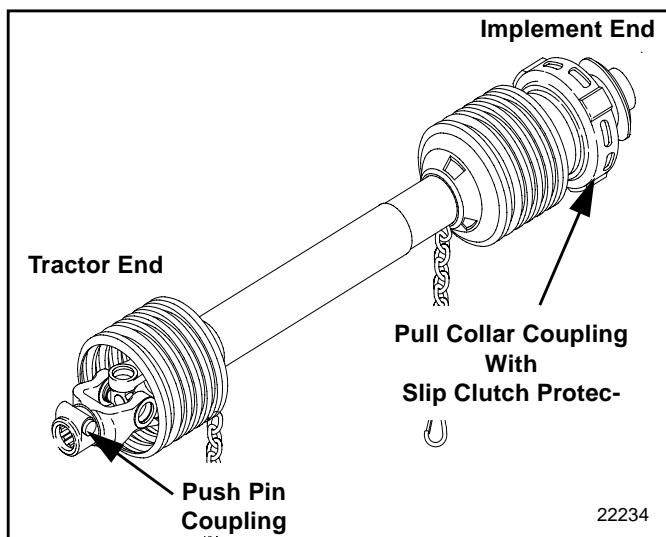
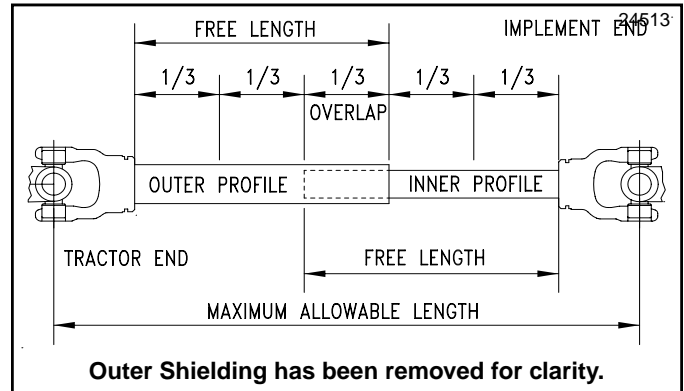

Figure 1-5

Section 1 Assembly and Set-Up

- b. Pull driveline apart into two sections as shown in Figure 1-6. Attach the outer driveline universal joint to the tractor shaft and inner driveline universal joint to the tiller gearbox shaft. Pull on each driveline section to be sure the universal joints are secured to the shafts.
 - c. Hold driveline sections parallel to each other to determine if they are too long. The inner and outer shields on each section should end approximately 1" short of reaching the universal joint shield on the adjacent section (see "B" dimension). If they are too long, measure 1" ("B" dimension) back from the universal joint shield and make a mark at this location on the inner and outer driveline shields.
 - d. Cut off inner shield at the mark ("X" dimension). Cut the same amount off the inner shaft ("X1" dimension). Repeat cut off procedure ("Y" & "Y1" dimensions) to the outer driveline half.
 - e. Remove all burrs and cuttings.
3. Attach inner driveline yoke end to the tiller gearbox input shaft.
 4. Attach outer driveline yoke end to the tractor's PTO shaft.
 5. The driveline should now be moved back and forth to insure that both ends are secured to the tractor and Rotary Tiller PTO shafts. Reattach any end that is loose.



Driveline Maximum Length
Figure 1-7

IMPORTANT: A small chain is supplied with the driveline. This chain must be attached to the inner driveline shield and to the tiller to restrict shield rotation.

6. Hook driveline safety chain in the hole in the inner driveline guard. Attach the other end to the tiller's main frame.
7. Start tractor and raise tiller just enough to remove blocks used to support the tiller frame in step 3a on page 10.
8. Slowly engage tractor's hydraulic 3-point to lower the Rotary Tiller. Check for sufficient drawbar clearance. Move drawbar ahead, aside or remove if required.
9. Raise and lower implement to find maximum extended driveline length. Check to make certain that the driveline overall length does not extend beyond the maximum recorded length in step 2.

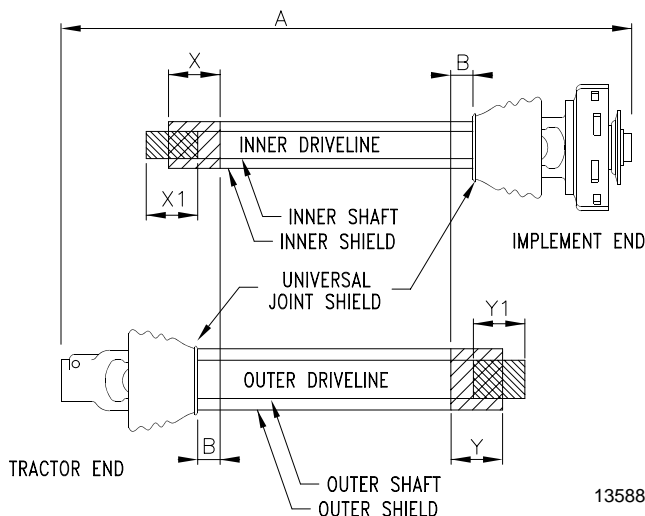

Shortening the driveline
Figure 1-6

Checking Driveline Maximum Length

Make sure you have gone through the steps in "Checking Driveline Minimum Length" on page 10 before checking maximum length.

Refer to Figure 1-7:

The driveline maximum length must, when fully extended, have a minimum overlap of the profile tubes by not less than 1/3 the free length with both inner and outer profile tubes being of equal length.

1. Apply multi-purpose grease to the inside of the outer shaft and reassemble the driveline.
2. Assemble the two driveline profiles together with just 1/3 overlapping of the profile tubes as shown in Figure 1-7. Measure and record this overall length for checking driveline length in step 9 below.

Section 2 Operating

General Notes for Field Operations

Before beginning to till, the following inspection should be performed:

1. Check oil level in gearbox and chaincase. Refer to the *Lubrication* portion of the “**Maintenance and Lubrication**” section on page 21.
2. Check that all plugs have been replaced properly in the gearbox and chaincase.
3. Check drive chain tension. Refer to the *Drive Chain* portion of the “**Adjustments**” section on page 15.
4. Be sure all tiller tines, bolts and nuts are tight.
5. Be certain all guards and shields are in place and secure.
6. Grease PTO shaft and all other grease fittings. Refer to the *Lubrication* portion of the “**Maintenance and Lubrication**” section on page 21.
7. Clear the area to be tilled of rocks, branches and other foreign objects.
8. Tall grass and weeds should be mowed before tilling.
9. Operate with 540 rpm PTO tractor.
10. At first begin tilling at a slow forward speed and shift up as ground conditions warrant.
11. Tiller should be operated with the tiller deck level to the ground.
12. Tiller tines will cut better at a faster rotor speed than at reduced throttle.
13. Do not engage PTO at full throttle.
14. Tilling should not be done in wet conditions as soil will stick to tines.
15. After tilling the first 50 feet, stop and check to see that the tiller is adjusted properly.
16. Do not make turns or attempt to back up while tiller is in the ground. See important note below.

IMPORTANT: Turning or backing up with rotary tines in the ground will damage the tiller.

17. Do not engage PTO with machine in the fully raised or lowered position.
18. Periodically check for foreign objects wrapped around the rotor shaft and remove them after disengaging PTO, turning off tractor, and removing ignition key.

Operating Check List

In addition to design and configuration of equipment, hazard control and accident prevention are dependent upon the awareness, concern, prudence and proper training involved in its operation, transport, maintenance and storage of equipment. Before beginning operation the following inspections should be performed.

<input type="checkbox"/>	Read and follow the “ Important Safety Information ” section on starting on page 1 carefully.
<input type="checkbox"/>	Read all of <i>Tractor Hookup</i> in the “ Assembly and Setup ” section on page 9.
<input type="checkbox"/>	Read all of the “ Operating Instructions ” section on page 12.
<input type="checkbox"/>	Lubricate the tiller as needed. Refer to the <i>Lubrication</i> portion of the “ Maintenance and Lubrication ” section on page 17.
<input type="checkbox"/>	Check the tiller initially and periodically for loose bolts & pins, using the <i>Torque Values Chart</i> in the “ Appendix ” section on page 27.
<input type="checkbox"/>	Make sure all guards and shields are in place.
<input type="checkbox"/>	Check initially and periodically for loose bolts, pins, and chains.

Transporting



CAUTION

When traveling on public roads whether at night or during the day, use accessory light and devices for adequate warning to operators of other vehicles. Comply with all federal, state and local laws.

IMPORTANT: Always disengage the driveline before raising the tiller to transport position.

1. When raising the tiller to the transport position, be sure that the driveline does not contact tractor or tiller. Adjust the tractor’s 3-point hitch lift height so that the tiller tines are not lifted more than 14 inches off the ground to prevent damage to the driveline.
2. Be sure to reduce tractor ground speed when turning, and leave enough clearance so the tiller does not contact obstacles such as buildings, trees or fences.
3. Select a safe ground travel speed when transporting from one area to another. When traveling on roadways, transport in such a way that faster moving vehicles may pass you safely.
4. When traveling over rough or hilly terrain, shift tractor to a lower gear.

Section 2 Operating

Parking

The following steps should be done when preparing to store the tiller or unhitch it from the tractor. See also *Storage* in the “**Maintenance and Lubrication**” section on page 20 for additional information on long term storage of your tiller.

1. Park the tiller on a level, solid area.
2. Shut off tractor engine and engage parking brake.
3. Set parking stand to desired height to maintain tiller in proper height for re-hook-up and install pin to lock in place.
4. Unhitch from tractor.
5. See *Storage* in the “Maintenance and Lubrication” section on page 20 if tiller is not going to be used for an extended period of time.

Operating Instructions

Before using your Land Pride RTA10 or RTA15 Series Rotary Tiller, you should have completely read the Operator’s Manual, properly attached the Tiller to the tractor, cut the driveline to proper length, Run-in the clutch, and gone through the Operating Checklist. If you have missed any of these steps, please complete them before proceeding.

Now that you have properly prepared yourself and your tiller, it’s time to do some tilling. Carefully drive the tractor to the site where you intend to till. **You should have already cleaned this site of any large limbs, rocks, trash, metal or other debris.** Best results will be achieved if you have mounted your tiller offset to the right far enough to cover the tread of your right tractor wheel. Line the tractor up just to the right of center on your tillage plot. You will be working from the center out and always turning to the right to line up for your next pass.

Lower the tiller half way to the ground and reduce your tractor engine speed to about one quarter throttle. Engage the PTO and gradually increase the engine speed until you reach full PTO speed of 540 rpm. Lower the Tiller to the ground and simultaneously commence forward travel of approximately 2 mph. Do not make turns or attempt to back up while tiller is in the ground. See important note below.

IMPORTANT: Turning or backing up with rotary tines in the ground will damage the tiller.

Travel about 50 ft. and then stop to check your results. When stopping, remember to lift the tiller out of the ground, stop the tractor, reduce engine speed, disengage the PTO, set the park brake, shut off the tractor, and remove the keys. If you are tilling too shallow or too deep, adjust the skid shoes accordingly. If the soil texture is too coarse, lower the leveling door and reduce your ground speed. If the soil texture is too fine, you will need to raise your leveling door and increase your ground speed. For any other problem conditions that may arise, you will want to refer to the Troubleshooting section on page 26.

When you are done tilling for the day, make sure you use proper tractor shut down procedures before you get off of the tractor. If you are detaching your tiller, make sure you park it on a dry and level surface leaving it clean and ready for the next use. When you put your tiller up for the season, make sure you refer to the Storage Directions on page 20.

With a little practice and a few adjustments, you will soon be achieving the results you want with your Land Pride Rotary Tiller. See “**Features and Benefits**” Section 6 or “**Specifications and Capacities**” Section 5 for additional information and performance enhancing options.

Section 3 Adjustments

RTA10 Tiller Hitch Offset

Refer to Figure 3-1:

By shifting the lower hitch clevises (#1) to the side, a limited amount of offset can be obtained.

CAUTION

After offsetting check to see that the PTO shaft clears all shields on the tiller, tractor and the tiller hitch. If not, decrease the offset until clearance is obtained.

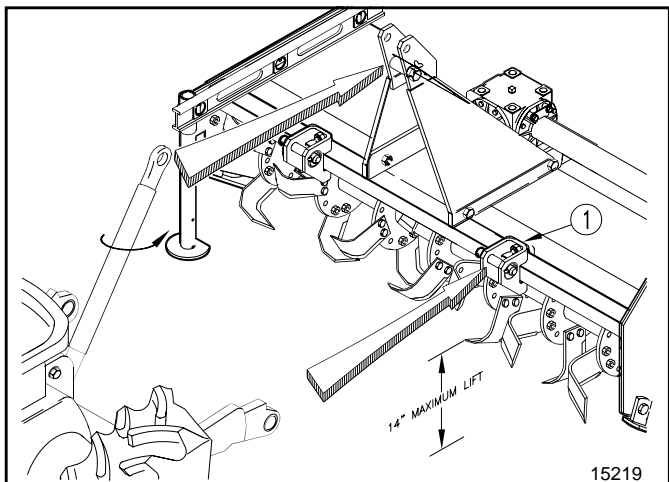

RTA Tiller Hitch Offset
Figure 3-1

RTA15 Tiller Hitch Sideshift

Refer to Figure 3-2:

The three point and gearbox can be sideshifted to the left of tiller center for various working conditions.

CAUTION

After sideshifting check to see that the PTO shaft clears all shields on the tiller, tractor and the tiller hitch. If not, decrease the sideshift until clearance is obtained.

6. Loosen the two u-bolts (#2) which hold the top hitch/gearbox frame (#1) to the front tube.
7. Loosen the two bolts (#3) which hold the top hitch/gearbox frame (#1) to the rear of the tiller.
8. Loosen the two u-bolts (#4) which hold the lower hitch clevises (#5) to the front tube.
9. Slide the top hitch/gearbox assembly to the desired location.
10. Re-center the lower hitch clevises with respect to the gearbox.

NOTE: For maximum offset, the left lower hitch clevis can be located on the left hand side of the left end plate.

Retighten all bolts and nuts referring to the *Torque Values Chart* in the "Appendix" section on page 27.

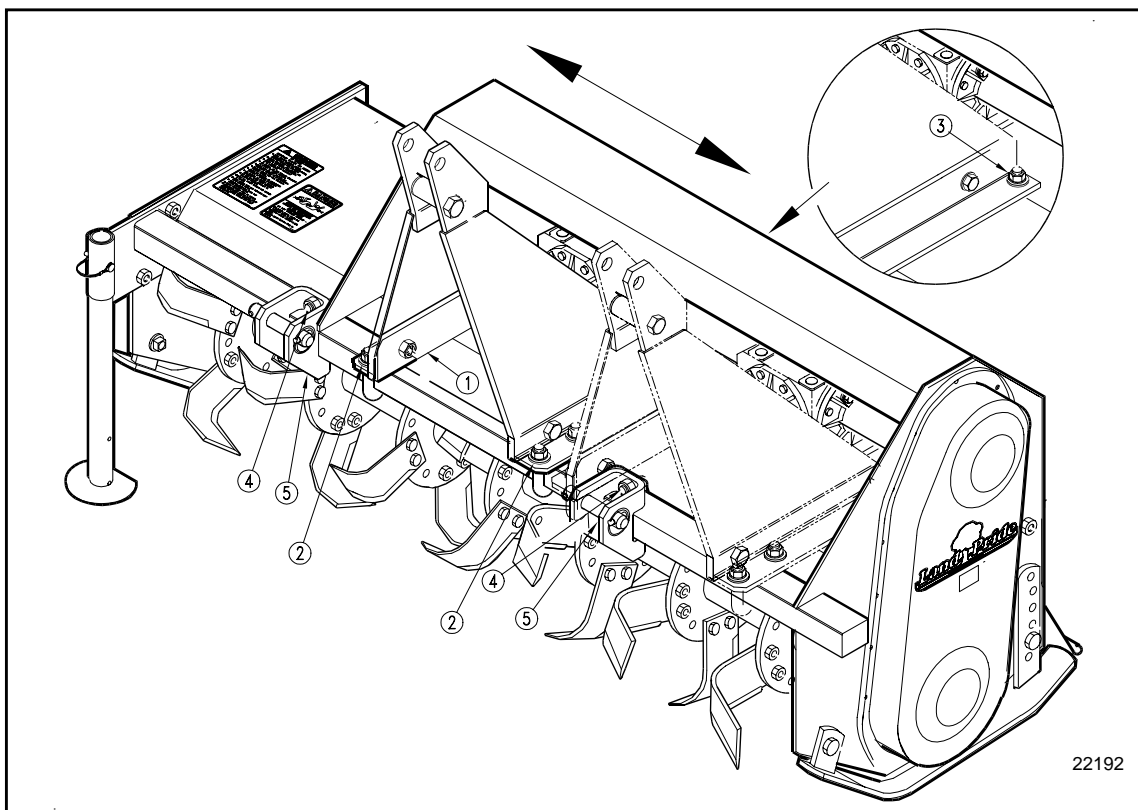

RTA15 Tiller Hitch Sideshift
Figure 3-2

Section 3 Adjustments

Drive Chain

Refer to Figure 3-3:

The tension on the drive chain can be easily adjusted by using the chain tightener stud. Should backlash occur, loosen the nut and torque the stud clockwise to 20 - 30 foot pounds and tighten nut to 400 foot pounds.

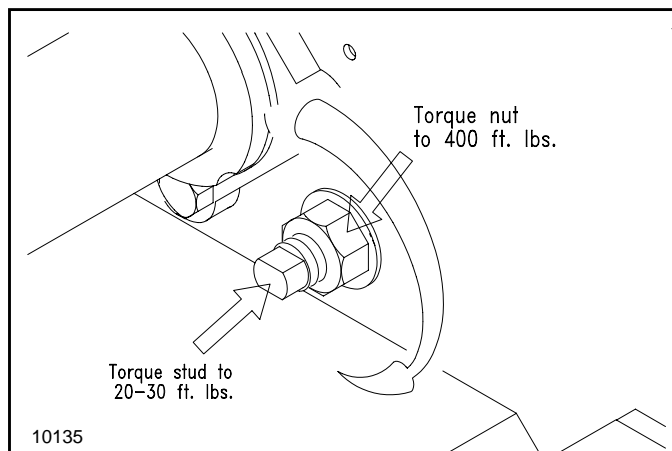

Chain Tightener
Figure 3-3

Rear Deflector

Refer to Figure 3-4:

The rear deflector can be adjusted closer to the ground to produce a fine soil texture or can be raised to produce a coarse soil texture by adjusting the chain length (#1) on the rear deflector.

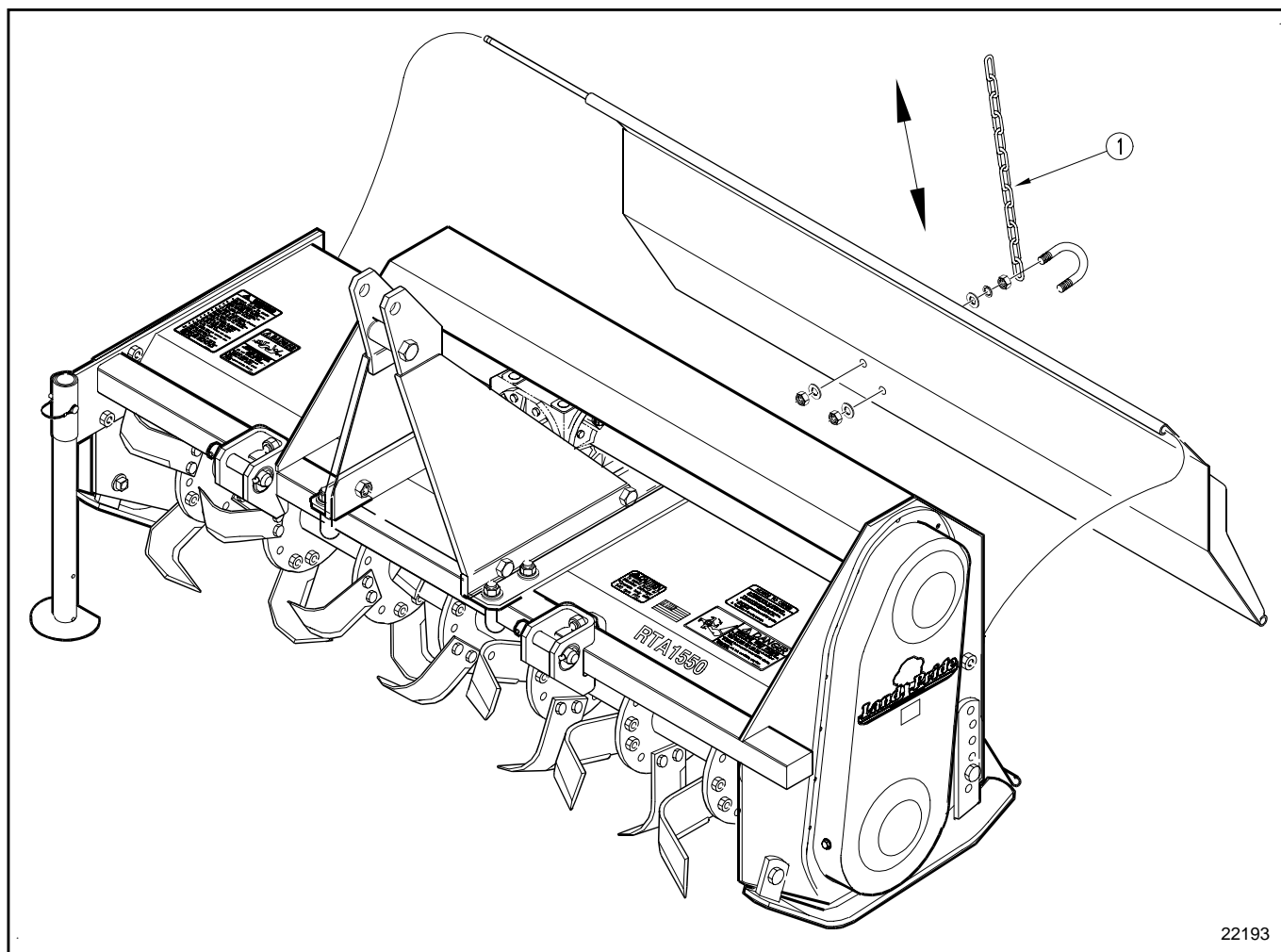

Rear Deflector
Figure 3-4

Section 3 Adjustments

Skid Shoe

Refer to Figure 3-5:

The skid shoes can be raised or lowered for the desired tilling depth by:

1. Raise tiller off the ground and properly support.
2. Loosen pivot bolt (#1) on front of shoe.

3. Remove adjusting bolt (#2) on rear of shoe.
4. Adjust skid (#3) shoe to desired location.
5. Install adjusting bolt, and tighten both the adjusting bolt and the pivot bolt.

IMPORTANT: Be sure both skid shoes are adjusted the same.

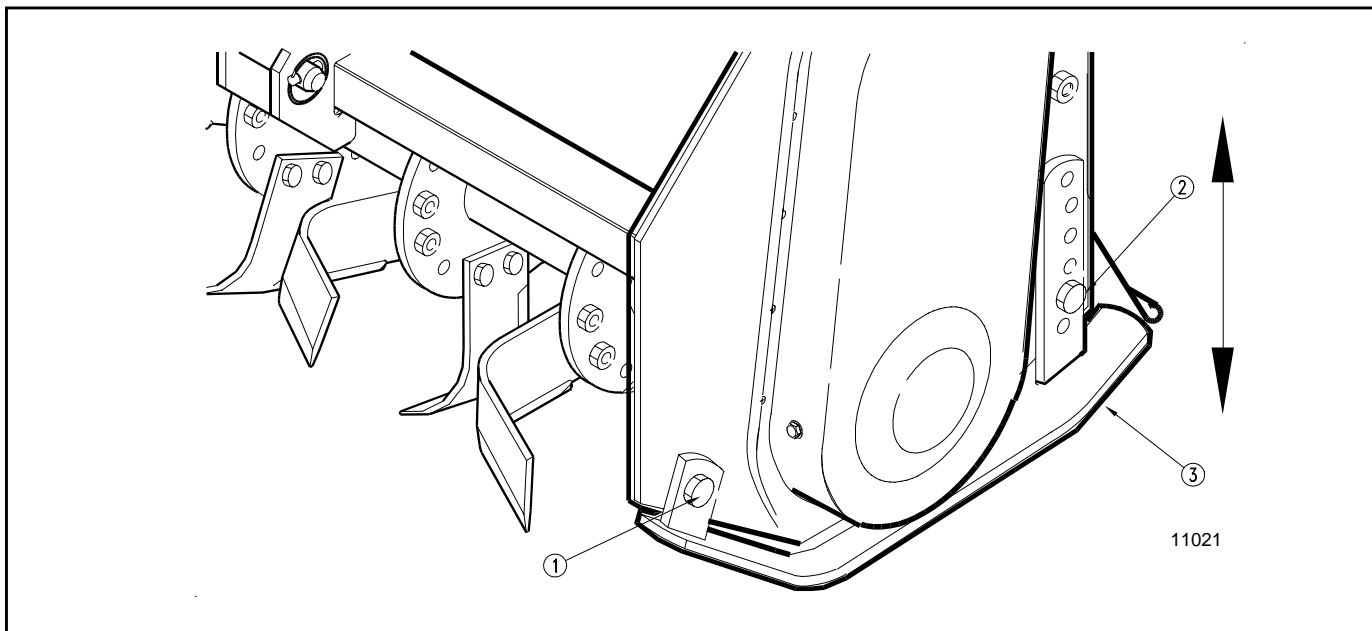

Skid Shoe Adjustment
Figure 3-5

Section 4 Maintenance and Lubrication

Maintenance



CAUTION

For safety reasons, each maintenance operation must be performed with the tractor's PTO disengaged, the Tiller lowered completely to the ground or on safely supported blocking, tractor engine shut off and ignition key removed.

Proper servicing and adjustment is the key to the long life of any farm implement. With careful and systematic inspection, you can avoid costly maintenance, time and repair.

After using your tiller for several hours, check all bolts to be sure they are tight.

Replace any worn, damaged or illegible safety labels by obtaining new labels from your Land Pride Dealer.

Tine Replacement

Refer to Figure 4-1:

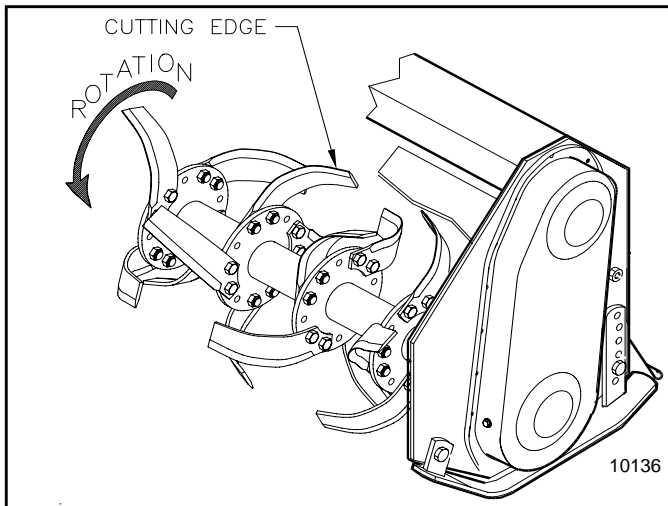

Tine Replacement
Figure 4-1

IMPORTANT: Always install tine with cutting edge facing direction of rotor shaft rotation. When ordering replacement tines, be sure to order both right and left hand tines.

6. Remove 2 cap screws and fasteners from tine to be replaced. Remove tine.
7. Install new tine on side of attaching flange as shown.
8. Replace 2 cap screws and fasteners and tighten nuts to proper torque. See *The Torque Values Chart* in the "Appendix" section on page 27.

IMPORTANT: Replace tines with genuine Land Pride tines only.



WARNING

Worn tines may be very sharp!

Driveline Protection

Tiller drive components are protected from shock loads with a friction clutch or a shear bolt. The clutch must be capable of slippage during operation to protect the gearbox, driveline and other drive train parts. Shear bolt protection is discussed on page 19.

Friction clutches should be "run-in" prior to initial operation and after long periods of inactivity to remove any oxidation that may have accumulated on the friction surfaces. Repeat "run-in" instructions at the beginning of each season and when moisture and/or condensation seizes the inner friction plates.

Refer to Figure 4-2 below and Figure 4-3 on page 19 to determine which friction clutch your tiller has. Follow run-in, disassembly and assembly instructions for your specific clutch.

Clutches With 4 Adjusting Nuts

Clutch Run-In

Refer to Figure 4-2 (View - A):

1. Using a pencil or other marker, scribe a line across the exposed edges of the clutch plates and friction disks.
2. Tighten all 4 nuts uniformly until spring load is low enough that the clutch slips freely with PTO engaged.

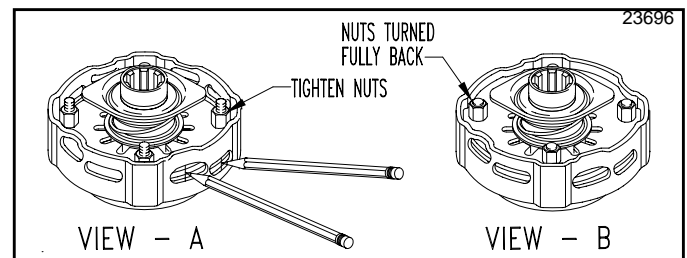

Clutches With 4 Adjusting Nuts
Figure 4-2

3. Start tractor and engage PTO for 2-3 seconds to permit slippage of clutch surfaces. Disengage PTO, then re-engage a second time for 2-3 seconds. Disengage PTO, shut off tractor and remove key. Wait for all components to stop before dismounting from tractor.
4. Inspect clutch and ensure that the scribed markings made on the clutch plates have changed position. Slippage has not occurred if any two marks on the friction disk and plate are still aligned. A clutch that has not slipped must be disassembled to separate the friction disk plates. See "Clutch Disassembly & Assembly" on page 18.

Refer to Figure 4-2 (View - B):

5. Turn all 4 nuts fully back if no two marks on the friction disk and plate are still aligned. Clutch is ready for use.
6. The clutch should be checked during first hour of cutting and periodically each week. An additional set of scribe marks can be added to check for slippage.

Section 4 Maintenance and Lubrication

Clutch Disassembly & Assembly

If clutch run-in procedure indicates that one or more of the friction disks did not slip, then the clutch must be disassembled to separate the friction disks.

NOTE: Before proceeding, secure clutch firmly in a vise or other clamping device to prevent injury.

2-Plate Disassembly

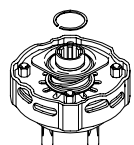

◀ **Step 1**
Remove snap ring.

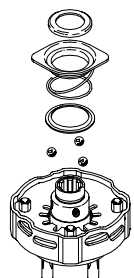

◀ **Step 2**
Remove backup ring, lock collar, compression spring, bottom backup ring, and balls.

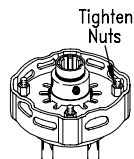

◀ **Step 3**
Tighten the four hex nuts uniformly until the clutch pack and hub are loose.

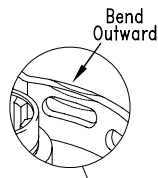

◀ **Step 4**
Bend all four retaining lugs out on edge of clutch housing.

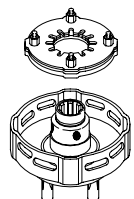

◀ **Step 5**
Remove thrust plate with Belleville Springs and lug rings to access friction disks and hub for inspection or service.

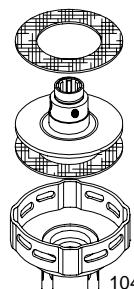

◀ **Step 6**
Inspect friction disks and hub.

10435

2-Plate Assembly

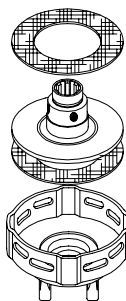

◀ **Step 1**
Place hub and friction disks into the housing.

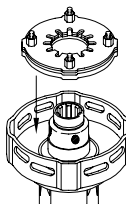

◀ **Step 2**
Compress Belleville Springs to the pressure plate by tightening the four hex nuts and then placing the assembly into the clutch housing.

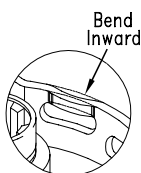

◀ **Step 3**
Bend retaining lugs inward over the Belleville Spring edges to secure the spring before backing the four hex nuts off.

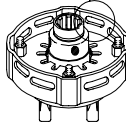

◀ **Step 4**
With lugs bent in, loosen the four hex nuts completely to the end of the threaded studs.

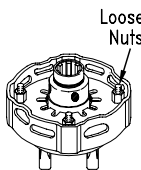

◀ **Step 5**
Insert greased balls.

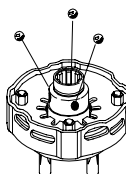

◀ **Step 6**
Install bottom backup ring, compression spring, lock collar, and top backup ring.

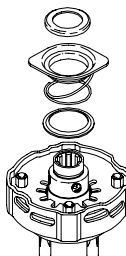

◀ **Step 7**
Install snap ring.

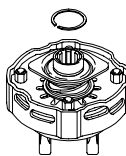

10449

Section 4 Maintenance and Lubrication

Clutches With 8 Hex Socket Bolts

Clutch Run-In

Refer to Figure 4-3 on page 19:

1. Loosen counterclockwise all 8 hex head socket bolts uniformly 6 full turns.
2. Cycle clutch on and off 5 or 6 times (15 seconds on and 15 seconds off) with the engine operating at half throttle. Disengage driveline, shut off tractor and remove key. Wait for all components to stop before dismantling from tractor.
3. Tighten hex head socket bolts fully back. Clutch is ready for use
4. The clutch should be checked during the first hour of cutting and periodically each week.

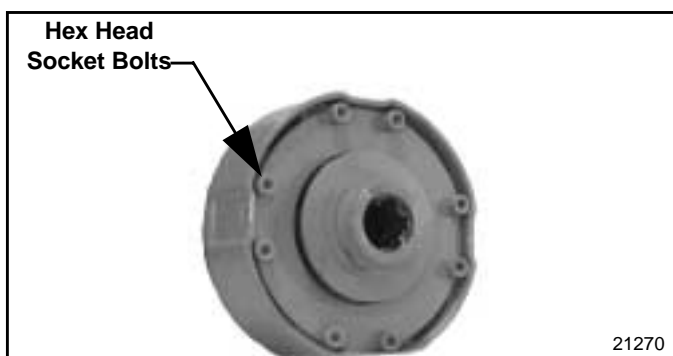

Clutch Run-In With 8- Hex Head Socket Bolts
Figure 4-3

Clutch Disassembly & Assembly

Refer to Figure 4-4 on page 19:

If clutch run-in procedure above indicated that one or more friction disks did not slip, then the clutch must be disassembled into separate friction disks.

1. Rotate 8 hex head socket bolts (#4) all the way out to free stop flange (#5).
2. Record position of the lips (up or down) on stop flange (#5) and then rotate flange and remove it.
3. Remove the following inner components:
 - a. Spring kit (#6)
 - b. Pressure flange (#7)
 - c. 1st Friction Disc (#8)
 - d. Hub with flange and pull collar (#2 & #3)
 - e. 2nd Friction disc (#8)
 - f. Bearing (#9)
4. Inspect all components and replace to their original position. Make certain stop flange (#5) is replaced with its flanges down as shown.
5. Fully tighten all 8 hex head socket bolts (#4).

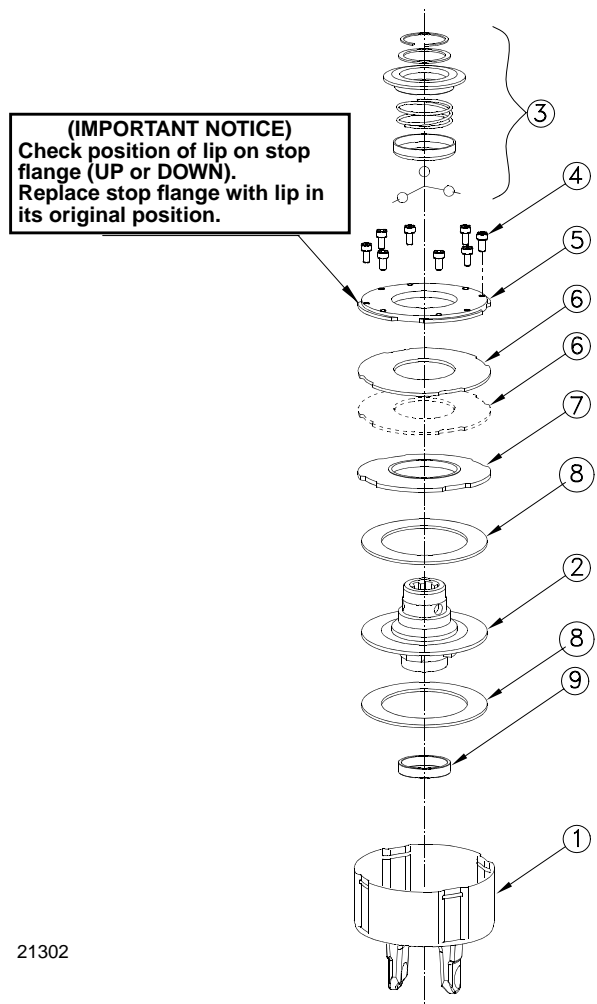

21302

Clutch Assembly
Figure 4-4

Shearbolt Protection

Avoid shear bolt breakage by making sure the tiller is out of the ground before engaging PTO and by engaging PTO slowly at low engine rpm. Increase engine speed to 540 RPM only after tines are rotating.

IMPORTANT: Replace damaged shear bolts with original Land Pride equipment from your Land Pride Dealer.

See table below for correct shear bolt and nut part numbers. Torque shear bolt nuts to 7-9 ft- lbs.

Shear Bolt and Lock Nut Part Numbers	
Part No.	Part Description
RTA10	
802-683C	M8 x 45 GR 8.8
803-278C	M8 Lock Nut (Torque nut to 7-9 ft. lbs.)
RTA15	
802-115C	5/16"-18 x 2 GR 5 bolt.
803-011C	5/16"-18 Lock Nut (Torque nut to 7-9 ft. lbs.)

Section 4 Maintenance and Lubrication

Storage



CAUTION

Engage parking brake, disengage PTO, shut off tractor, and remove key before making any of the following adjustments.

At the end of the working season or when the tiller will not be used for a long period, it is good practice to clean off any dirt or grease that may have accumulated on any of the moving parts.

Check the tines for wear and replace if necessary. See *Tine Replacement* in this section.

Inspect the tiller for loose, damaged or worn parts and adjust or replace if needed.

Lubricate as noted in *Lubrication* in this section.

Repaint parts where paint is worn or scratched to prevent rust.

Drain gearbox and chaincase oil. Drain oil in gearbox by removing the bottom drain plug, or right hand cap. Drain oil in chaincase by removing the bottom plug and tipping tiller backwards. Be sure to refill gearbox and chaincase at this time.





Store tiller in a clean, dry place.

Inspect the tiller for loose, damaged or worn parts and adjust or replace if needed.



Section 4 Maintenance and Lubrication

Lubrication

Lubrication Legend

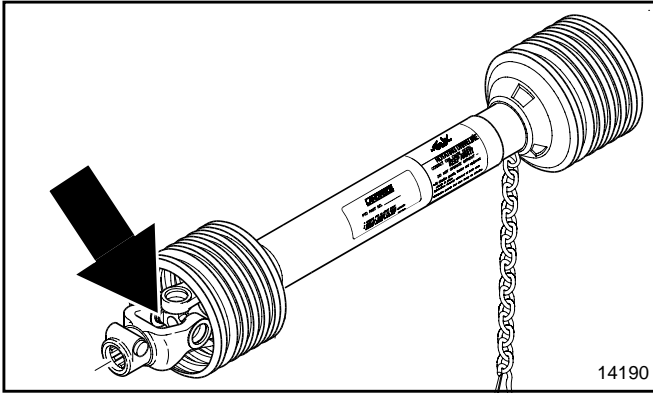
 Multi-purpose spray lube	 Multi-purpose grease lube	 Multi-purpose oil lube	 20 Intervals in hours at which lubrication is required.
------------------------------------------------------------------------------------------------------------	-------------------------------------------------------------------------------------------------------------	-----------------------------------------------------------------------------------------------------------	------------------------------------------------------------------------------------------------------------------------------------------------



	 8 Hrs
-------------------------------------------------------------------------------------	----------------------------------------------------------------------------------------------



Driveline U-Joint

Coat driveline u-joint with grease every 8 hours of operation

Type of grease = Multi-Purpose

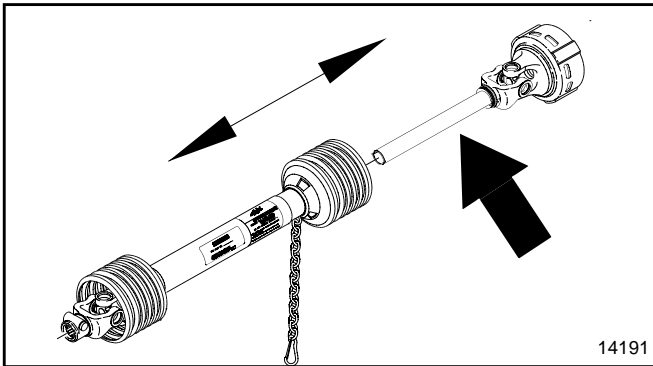
Quantity = Coat Generously



	 20 Hrs
--------------------------------------------------------------------------------------	------------------------------------------------------------------------------------------------

Driveline Shaft

Disconnect driveline shaft from the tractor and slide apart. Clean and coat the inner tube of the driveline shaft with a light film of grease and then reassemble.

Type of grease = Multi-Purpose

Quantity = Coat Generously

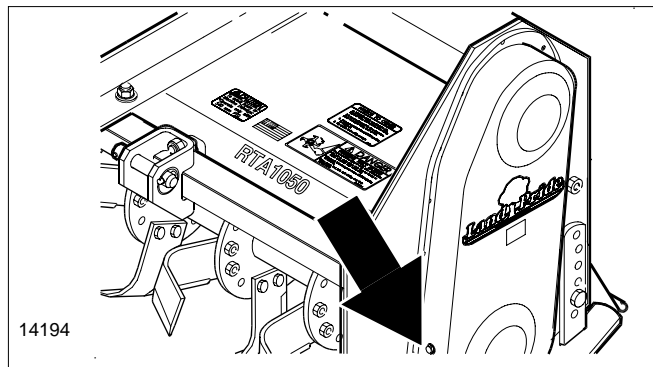

	 As Required
---------------------------------------------------------------------------------------	------------------------------------------------------------------------------------------------------

Chaincase

With tiller on level ground, check oil level in chaincase by removing lower plug. Oil should reach the plug hole. Fill if necessary with Shell Alvania EP 00 oil and retighten plug. Tiller should be level when checking.

Type = Recommended: Shell Alvania EP00 Oil

Alternate: Gear Lube 80-90W EP

Quantity = As required

Section 4 Maintenance and Lubrication

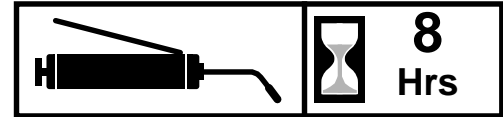
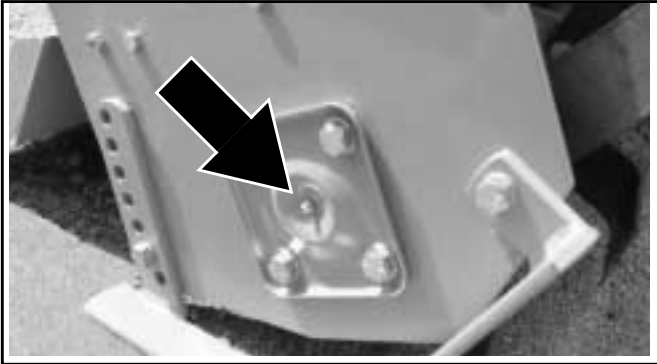

Bearing On Right End Of Rotor Shaft

Type of Lubrication: Multi-Purpose

Quantity = As Required

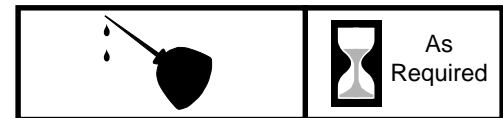
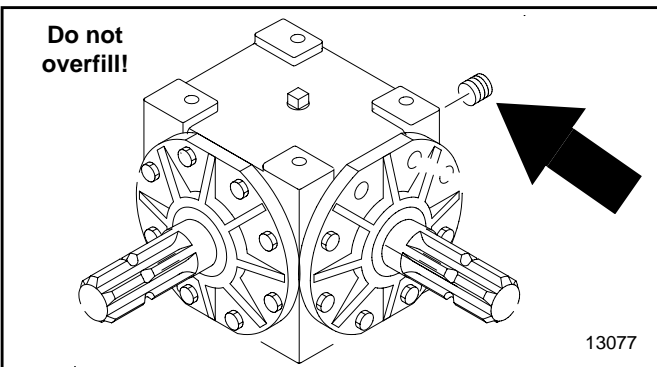

Side Plug Gearbox

Check oil every 50 hours of operation. Check the oil level in the gearbox by removing the plug in the side of the box. The oil should reach the plug hole.

Type of Lubrication: Gear Lube 80-90W EP

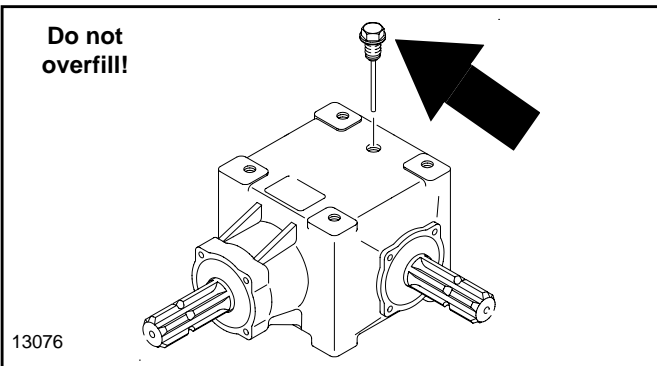

Top Plug Gearbox (10 Series)

Check oil every 50 hours of operation. Check the oil level in the gearbox by removing the dipstick in the top of the box.

Type of Lubrication: Gear Lube 80-90W EP

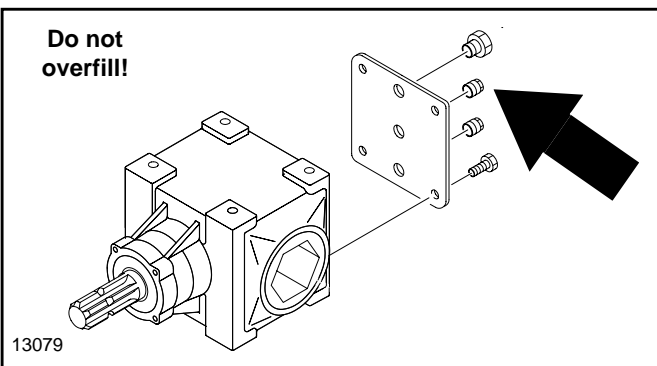

Top Plug Gearbox (15 Series)

Check oil every 50 hours of operation. Check the oil level in the gearbox by removing the center plug at the rear of the box, oil should come to bottom of center plug.

Type of Lubrication: Gear Lube 80-90W EP

Section 5 Specifications and Capacities

RTA10 Series Rotary Tiller			
	RTA1042	RTA1050	RTA1058
Width	42"	50"	58"
Overall Width	47 5/16"	55 5/16"	63 5/16"
Weight	358#	385#	415#
Number of flanges	5	6	7
Number of Tines per Flange	4	4	4
Driveline	Category II Shear bolt - standard Slip Clutch - optional		
Gearbox	25 HP input at 540rpm 1.5:1 ratio Cast iron housing, straight bevel gears		
Gearbox Lubrication	Gear Lube 80-90W EP		
Drive Chain	#80 roller chain in flowable grease bath		
Drive Chain Lubrication	Shell Alvania EP 00 or equivalent		
Sprockets	Case hardened teeth, splined bores		
Rotor Swing Diameter	15"		
Rotor Shaft Speed	225 rpm at 540 rpm PTO		
Recommended Maximum PTO HP	25 HP		
Hitch Type	Category I, offsetable, works with Land Pride Quick-Hitch (Note: Cannot be offset when using the Quick-Hitch)		

RTA15 Series Rotary Tiller		
	RTA1550	RTA1558
Width	50"	58"
Overall Width	56 1/4"	64 1/4"
Weight	412#	444#
Number of Flanges	6	7
Number of Tines per Flange	4	
Driveline	Category III Heavy Duty Shear bolt - standard Friction Clutch - optional	
Gearbox	35 HP input at 540 rpm 1.92:1 ratio Cast iron housing, straight bevel gears	
Gearbox Lubrication	Gear Lube 80-90W EP	
Drive Chain	#80 roller chain in flowable grease bath	
Drive Chain Lubrication	Shell Alvania EP 00 or equivalent	
Sprockets	Case hardened teeth, splined bores	
Rotor Swing Diameter	15"	
Rotor Shaft Speed	211 rpm at 540 rpm PTO	
Recommended Maximum PTO HP	35 HP	
Hitch Type	Category I, Sideshift capabilities, works with Land Pride Quick-Hitch (Note: Sideshift capabilities also works with Land Pride Quick-Hitch)	



RTA10 Series Rotary Tiller

Features	Benefits
5 Pack pricing	Order in pack of 5 to save money.
Working widths	42", 50", 58" to meet a wide range of applications and needs.
Gearbox Warranty	3 Years on housing, gears, seals, and bearings. Shows our confidence in the product.
Tractor HP range	17-25 HP
Fits Land Pride Quick-Hitch	Allows for quick and easy one person hook-up. Does not offset with Quick-Hitch.
Formed and reinforced rear deflector	Keeps dirt in and leaves a level finish. Forming gives deflector additional strength. Adjustable deflector allows for various finish results.
Clevis hitch	Provides additional strength and easy one person hook-up.
Adjustable lower hitches	Offset unit to cover right tire track.
Skid shoes	Control depth with seven adjustments.
6 1/2" Digging depth	For deep soil penetration.
Adjustable Parking stand	Easy hook-up and storage.
Plate steel hitch	Plate steel is stronger than flat bar type hitch
4 'C' shaped tines per flange	'C' Shaped tines require less HP to move through the ground.
Solid rotor shaft	1 3/4" Solid steel rotor shaft for strength.
15" Rotor swing diameter	For deep tilling and turning the soil over faster.
#80 Drive chain enclosed in oil bath	Heavy drive chain stretches less, and oil bath keeps wear to a minimum.
Stamped chain cover	Stamped forming gives the chain cover strength.
Fully shielded shear pin or slip-clutch driveline	Protects the gearbox and rotor shaft upon hitting obstructions. Slip-clutch saves having to replace shear-pins.
American made	Many tillers are imported. American made means better parts availability.
Double lip seal on rotor bearing	Double lip seal helps keep the dirt out and the grease in.
Offset Dimensions	42" width 16"-26" std. 13"-29" Maximum Right 23"-19" Maximum Left
	50" width 25"-25" std. 18"-32" Maximum Right 32"-18" Maximum Left
	58" width 29"-29" std. 22"-36" Maximum Right 36"-22" Maximum Left

Section 6 Features and Benefits







RTA15 Series Rotary Tiller

Features	Benefits
Working widths	50", 58" to meet specific customer needs.
Tractor HP range	17 - 35 HP
Gearbox warranty	5 Year on housing, gears, seals and bearings. Shows our confidence in the product.
Fits Land Pride Quick-Hitch	Allows for quick and easy one person hook-up. Cannot be used with offset.
Sideshift capabilities	Sideshift tiller to cover right tire track. Gearbox slides with tiller.
Sideshift dimensions 50"	25-25 Std.; 12-38 Max. right; 31-19 Max. left
Sideshift dimensions 58"	29-29 Std.; 12-46 Max. right; 35-12 Max. left
Formed and reinforced rear deflector	Forming gives deflector additional strength. Adjustable deflector allows for various finish results.
Clevis hitch	Provides additional strength and easy one person hook-up.
Skid Shoes	Control depth with various settings.
6 1/2" Digging depth	For deep soil penetration.
Adjustable Parking Stand	Easy hook-up and storage.
Plate steel hitch	Plate steel is stronger than flat bar type hitch.
4 'C' Shaped heat-treated tines per flange	'C' Shaped tines require less HP to move through the ground.
Solid rotor shaft	1 3/4" Solid steel shaft for strength.
Cat. 3 Driveline	Cat. 3 Driveline with heavy-duty shear-bolt or slip-clutch
15" Rotor swing diameter	For deep tilling and turning the soil over faster.
Double lip seal on rotor bearing	Double lip seal helps keep the dirt out and the grease in.
#80 Drive chain enclosed in oil bath	Heavy drive chain stretches less, and oil bath keeps wear to a minimum.
Stamped chain cover	Stamped forming gives the chain cover strength.
Fully shielded shear pin or slip-clutch driveline	Protects the gearbox and rotor shaft upon hitting obstructions. Slip-clutch saves having to replace shear-pins.

Problem	Cause	Solution
Machine makes intermittent clicking noise	Loose tines Gearbox tooth damaged Chain damaged	Tighten tines Replace damaged gear Replace damaged chain link
PTO vibrates	Worn universal joint Excessive trash wrapped on rotor Machine lifted too high	Replace universal joint Remove trash Lower machine and readjust tractor lift stop
Gearbox noise is noticeable and constant	May be normal on new machine Low oil level Worn gears	Allow time for break-in Add oil Replace gears
Oil leaking from gearbox	Damaged seals or gaskets Gearbox overfilled	Replace seals or gaskets Drain to proper level
Rotor will not turn	PTO not engaged Broken drive chain Driveline shearbolt sheared Friction clutch slipping	Engage PTO Repair drive chain Replace shearbolt Reduce load to tiller
Tillage depth insufficient	Tiller carried by tractor Insufficient power Skid Shoes need adjusting Worn or bent tines Tines incorrectly installed Obstacles entangled in tines and/or rotor Lower hitch clevises on tiller in wrong position	Lower tractor 3-point arms Increase tractor rpm Adjust skid shoes Replace tines Check tine placement Clear rotor and/or tines Relocate lower hitch clevises
Soil texture too coarse	Leveling door too high PTO speed too slow Ground speed too fast	Lower leveling door Increase PTO speed Decrease ground speed
Soil texture too fine	Leveling door too low Ground speed too slow	Raise leveling door Increase Ground Speed
Machine skips or leaves crop residue	Badly worn tines Friction clutch slipping Ground speed too fast for conditions	Replace worn tines Reduce load Reduce ground speed
Tines balling up with soil	Worn or bent tines Tines incorrectly installed Rear deflector too low Tractor speed too fast Soil too wet	Replace tines Install tines correctly Raise rear deflector Decrease tractor speed Wait until soil dries
Tiller bumping on ground	Obstacles entangled in tines and/or rotor Tines not installed correctly	Clear rotor and/or tines Install tines correctly



Section 8 Appendix

Torque Values Chart														
Bolt Size (Inches)	Bolt Head Identification						Bolt Size (Metric)	Bolt Head Identification						
	 Grade 2		 Grade 5		 Grade 8			 Class 5.8		 Class 8.8		 Class 10.9		
	in-tpi ¹		N · m	ft-lb ³	N · m	ft-lb		N · m	ft-lb	mm x pitch	N · m	ft-lb	N · m	ft-lb
1/4" - 20	7.4	5.6	11	8	16	12	M 5 X 0.8	4	3	6	5	9	7	
1/4" - 28	8.5	6	13	10	18	14	M 6 X 1	7	5	11	8	15	11	
5/16" - 18	15	11	24	17	33	25	M 8 X 1.25	17	12	26	19	36	27	
5/16" - 24	17	13	26	19	37	27	M 8 X 1	18	13	28	21	39	29	
3/8" - 16	27	20	42	31	59	44	M10 X 1.5	33	24	52	39	72	53	
3/8" - 24	31	22	47	35	67	49	M10 X 0.75	39	29	61	45	85	62	
7/16" - 14	43	32	67	49	95	70	M12 X 1.75	58	42	91	67	125	93	
7/16" - 20	49	36	75	55	105	78	M12 X 1.5	60	44	95	70	130	97	
1/2" - 13	66	49	105	76	145	105	M12 X 1	90	66	105	77	145	105	
1/2" - 20	75	55	115	85	165	120	M14 X 2	92	68	145	105	200	150	
9/16" - 12	95	70	150	110	210	155	M14 X 1.5	99	73	155	115	215	160	
9/16" - 18	105	79	165	120	235	170	M16 X 2	145	105	225	165	315	230	
5/8" - 11	130	97	205	150	285	210	M16 X 1.5	155	115	240	180	335	245	
5/8" - 18	150	110	230	170	325	240	M18 X 2.5	195	145	310	230	405	300	
3/4" - 10	235	170	360	265	510	375	M18 X 1.5	220	165	350	260	485	355	
3/4" - 16	260	190	405	295	570	420	M20 X 2.5	280	205	440	325	610	450	
7/8" - 9	225	165	585	430	820	605	M20 X 1.5	310	230	650	480	900	665	
7/8" - 14	250	185	640	475	905	670	M24 X 3	480	355	760	560	1050	780	
1" - 8	340	250	875	645	1230	910	M24 X 2	525	390	830	610	1150	845	
1" - 12	370	275	955	705	1350	995	M30 X 3.5	960	705	1510	1120	2100	1550	
1-1/8" - 7	480	355	1080	795	1750	1290	M30 X 2	1060	785	1680	1240	2320	1710	
1 1/8" - 12	540	395	1210	890	1960	1440	M36 X 3.5	1730	1270	2650	1950	3660	2700	
1 1/4" - 7	680	500	1520	1120	2460	1820	M36 X 2	1880	1380	2960	2190	4100	3220	
1 1/4" - 12	750	555	1680	1240	2730	2010	¹ in-tpi = nominal thread diameter in inches-threads per inch ² N · m = newton-meters ³ ft-lb= foot pounds ⁴ mm x pitch = nominal thread diameter in millimeters x thread pitch							
1 3/8" - 6	890	655	1990	1470	3230	2380								
1 3/8" - 12	1010	745	2270	1670	3680	2710								
1 1/2" - 6	1180	870	2640	1950	4290	3160								
1 1/2" - 12	1330	980	2970	2190	4820	3560								

Torque tolerance + 0%, -15% of torquing values. Unless otherwise specified use torque values listed above.

Notes

Warranty

Land Pride warrants to the original purchaser that this Land Pride product will be free from defects in material and workmanship beginning on the date of purchase by the end user according to the following schedule when used as intended and under normal service and conditions for personal use.

Overall Unit and Driveline: One year Parts and Labor

Gearbox: 5 years Parts and Labor

Tines and Driveline Friction Discs: Considered wear items

This Warranty is limited to the replacement of any defective part by Land Pride and the installation by the dealer of any such replacement part, and does not cover common wear items such as blades, belts, tines, etc. Land Pride reserves the right to inspect any equipment or parts which are claimed to have been defective in material or workmanship.

This Warranty does not apply to any part or product which in Land Pride's judgment shall have been misused or damaged by accident or lack of normal maintenance or care, or which has been repaired or altered in a way which adversely affects its performance or reliability, or which has been used for a purpose for which the product is not designed. Misuse also specifically includes failure to properly maintain oil levels, grease points, and driveline shafts.

Claims under this Warranty must be made to the dealer which originally sold the product and all warranty adjustments must be made through such dealer. Land Pride reserves the right to make changes in materials or design of the product at any time without notice.

This Warranty shall not be interpreted to render Land Pride liable for damages of any kind, direct, consequential, or contingent to property. Furthermore, Land Pride shall not be liable for damages resulting from any cause beyond its reasonable control. This Warranty does not extend to loss of crops, any expense or loss for labor, supplies, rental machinery or for any other reason.

No other warranty of any kind whatsoever, express or implied, is made with respect to this sale; and all implied warranties of merchantability and fitness for a particular purpose which exceed the obligations set forth in this written warranty are hereby disclaimed and excluded from this sale.

This Warranty is not valid unless registered with Land Pride within 30 days from the date of purchase by the end user.



Corporate Office: P.O. Box 5060
Salina, Kansas 67402-5060 USA
www.landpride.com

Free Manuals Download Website

<http://myh66.com>

<http://usermanuals.us>

<http://www.somanuals.com>

<http://www.4manuals.cc>

<http://www.manual-lib.com>

<http://www.404manual.com>

<http://www.luxmanual.com>

<http://aubethermostatmanual.com>

Golf course search by state

<http://golfingnear.com>

Email search by domain

<http://emailbydomain.com>

Auto manuals search

<http://auto.somanuals.com>

TV manuals search

<http://tv.somanuals.com>