

Lanzar®

USER'S MANUAL

vibe



AMPLIFIERS:

VIBE1801D

VIBE3200D

WWW.LANZAR.COM

TABLE OF CONTENTS

1. Contents
2. Introduction
3. Features
4. Specifications
5. Amplifier installation
- 6.7. Features and controls
- 8.9.10.11. System wiring
- 12.13. Troubleshooting

INTRODUCTION

Thank you for purchasing the Lanzar VIBE Class-D amplifier. Rest assured you have purchased a quality product designed and engineered to give you many years of uncompromised musical service. The VIBE Class-D amplifier has been designed using the latest in electronic technology available today.

This mono subwoofer amplifier is the result of advanced high speed switching technology that overcomes the less-efficient classAB design. The VIBE Class-D amplifier reflects your true appreciation for powerful bass reproduction in the mobile environment.

This amplifier is designed for low-frequency information only and it is not capable of reproducing any mid/high-frequency information.

This is due to the noise introduced into the signal by the switching speed of the power supply, which must be filtered out of the audio signal.

The power supply incorporated into VIBE amplifier is a DC to DC switching power supply designed to have adequate headroom for even the most demanding peak and dynamic range found on today's CDs and recording.

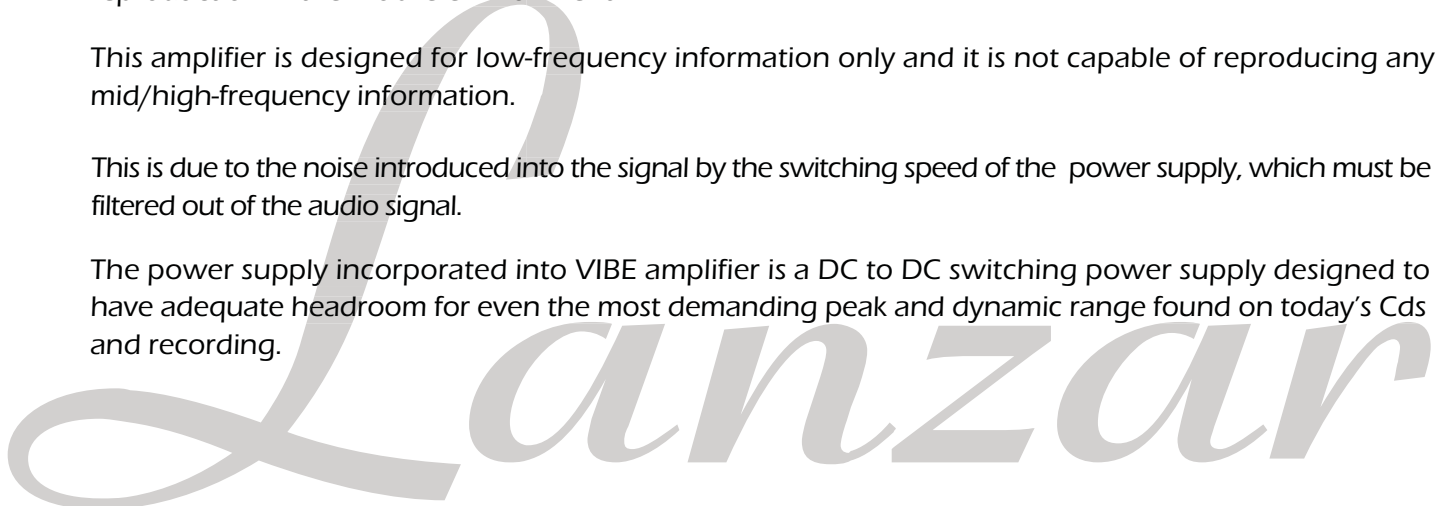

- **CLASS-D DESIGN**

Low - frequency information for subwoofer only.
High efficient power

- **POWER SUPPLIES**

Stiffly regulated PWM power supplies.
MOSFET switches maintain rated power over a wide range of battery voltages.

- **LOW PASS FILTER**

Adjustable from 50Hz to 150Hz with a slope of 24dB per octave.
This allows for the adjustment of the upper point of the frequency bandwidth and the respective subwoofer.

- **VARIABLE SUBSONIC FILTER**

Adjustable from 15Hz to 40Hz (VIBE1801D) / 10Hz -40Hz (VIBE3200D) with a slope of 24dB per octave.
This allows for the attenuation of frequencies that are mostly inaudible and cause unnecessary strain on the amplifier.

- **PROTECTION CIRCUITRY**

Protection against thermal, Overload and short circuit conditions.

- **REMOTE DASH-MOUNT GAIN CONTROL**

This amplifier come complete with a compact remote GAIN CONTROLLER which can be conveniently mounted on or under the dashboard of your car.

SPECIFICATIONS

MODEL	VIBE1801D <small>mono channel amplifier</small>	VIBE3200D <small>mono channel amplifier</small>
RMS Power, INTO 4 Ohms	1X400W	1200W
RMS Power, INTO 2 Ohms	1X800W	2200W
RMS Power, INTO 1.3 Ohms	1X900W	2400W
MAX Power, INTO 1.3 Ohms	1X1800W	3200W
BRIDGE MAX Power, INTO 2 Ohms	1X3600W	6400W
THD at 1 Watt, 4 Ohm	0.5%	0.5%
Signal-to-Noise Ratio, below rated power output	95	95
Frequency Response, at 1Watt,4 Ohm	15Hz to 150Hz	15Hz to 150Hz
Damping Factor at 20Hz, 4 Ohm	300	300
Low Pass Filter	50Hz ~ 150Hz	50Hz ~ 150Hz, 24dB/Octave
Variable Subsonic Filter	15Hz ~ 40Hz	10Hz ~ 40Hz, 24dB/Octave
Bass Boost	0+18dB	0+18dB
Phase Control	0° to 180°	0° to 180°
Input Sensitivity	200mV to 8V	200mV to 8V
Input Impedance	10K Ohm	10K Ohm
Line Output Impedance	100 Ohm	100 Ohm
Dimensions(Inches)	10.25"x2.36"x15.10"	10.25"x2.36"x21.06"
Fuse Rating	40Ax4	250A (Not Included)

1. Find a suitable location in the vehicle to mount the amplifier.
2. Make sure there is sufficient air flow around the intended mounting location.
3. Bolt the amplifier to the mounting surface.
4. Connect the power ground terminal to the nearest point on the chassis of the car. Keep this ground wire less than one meter (39") in length. Use 4 gauge wire.
5. Connect the remote terminal to the remote output of the head unit using 14 gauge.
6. Connect an empty fuse holder within 300mm (12") of the battery and 4 gauge or larger high quality cable from this fuse to the amplifier location.
7. Make sure there is no fuse in this fuse holder. Then make the connection to the "BATT" connection on the amplifier.
8. If multiple amplifiers are being used, use cables (each with its own fuse at the battery) or a #0 or a #2 cable from the fuse holder at the battery to a distribution block at or near the amplifier's location.
9. Connect all line inputs and outputs using high-quality RCA-RCA cables.
10. Insert fuse(s) at the battery fuse holder(s).
11. Recheck all connections before powering up.
12. Set all level controls to their least sensitive positions and set all crossover controls, switches, etc. to the desired frequency or position.
13. Once the system is powered up , set the volume control on the head unit to about the 2 o'clock position, and then set all the amplifiers' level controls for maximum output level.
14. Further fine tuning of the various controls may be necessary to obtain the desired results.

FEATURES AND CONTROLS

VIBE1801D

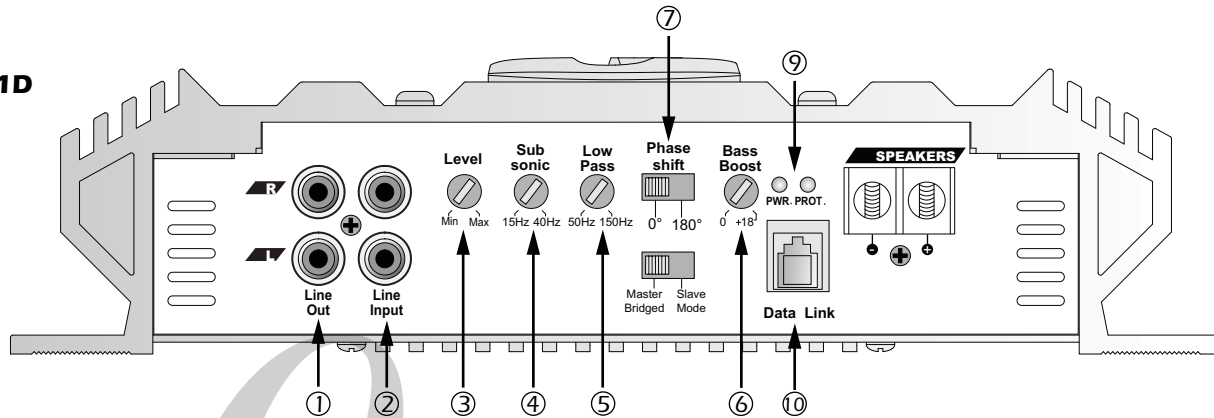

VIBE3200D

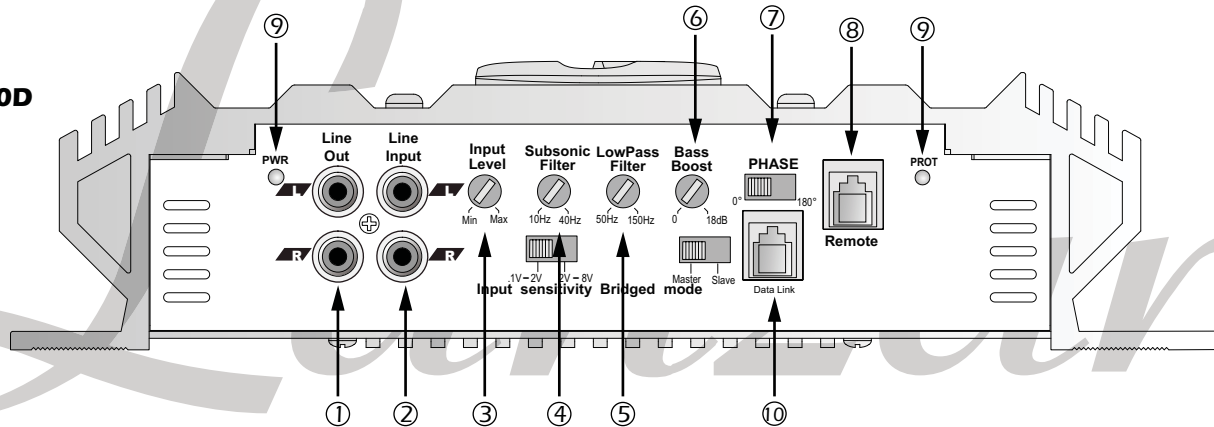

- 1. Line Out RCA Jacks** - The LINE OUT allows you to build multiple amplifier systems without having to use splitter cords to distribute the signal. Now it is simple a matter of bringing one set of RCAs into the first amplifier, then using the line out RCA jacks as the feed to the next amplifier.
- 2. Line Input RCA Jacks** - These inputs are for signal cables from the source. Always use high quality shielded RCA cables.
- 3. Input Level Controls** - Enables the matching of input levels to the output levels from the head unit(or other signal source).
- 4. Variable Subsonic Filter** - 15Hz~40Hz (VIBE1801D), 10Hz - 40Hz (VIBE3200D)
- 5. Low Pass Filter** - When Crossover Mode Selector is in Low Pass Mode, this control limits the frequencies which will be distributed to the speakers to those below the value to which this is set within the range 50Hz~ 150Hz.
- 6. Variable Bass Boost Control** - 0 ~ +18dB
- 7. Phase Shift** - Allows you to change the phase of your subwoofer from 0 to 180 degrees to help compensate for timing differences between drivers.
- 8. Bass Boost Remote Control Input**
- 9. Power & Protection Indicators**- Provide instant information on status of amplifier, including short-circuit and thermal overload alerts.
- 10. Brigde Mode**

SYSTEM WIRING

VIBE1801D

■ SIGNAL INPUT AND BYPASS OUTPUT CONNECTION

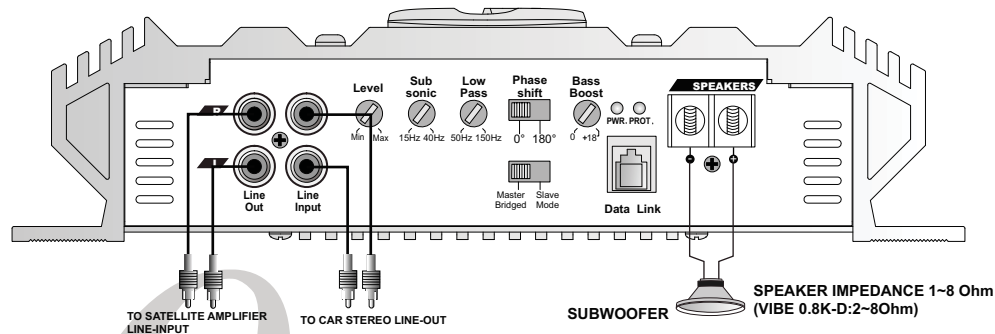

■ SPEAKER OUTPUT CONNECTION

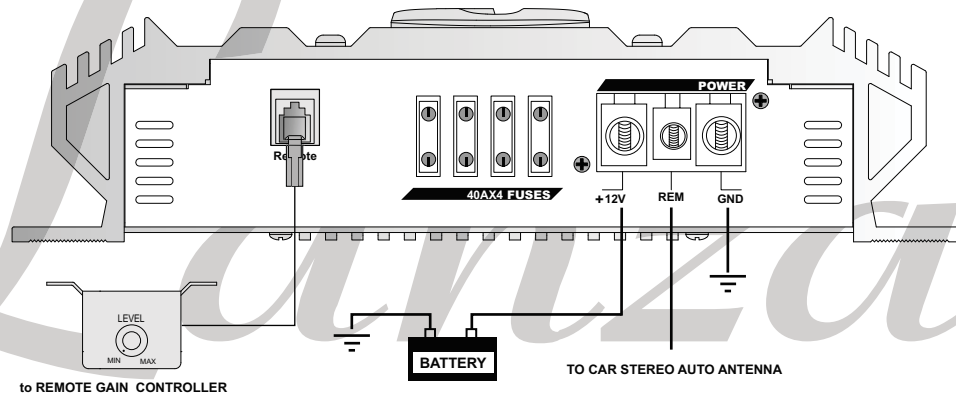

■ SIGNAL INPUT AND BYPASS OUTPUT CONNECTION

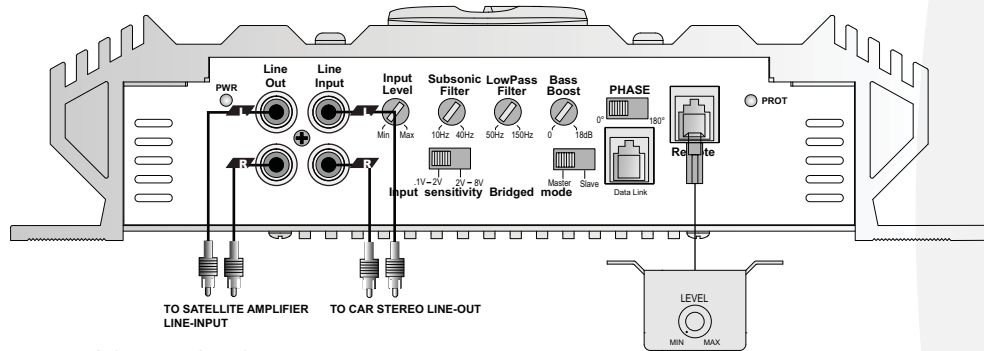

■ SPEAKER OUTPUT CONNECTION

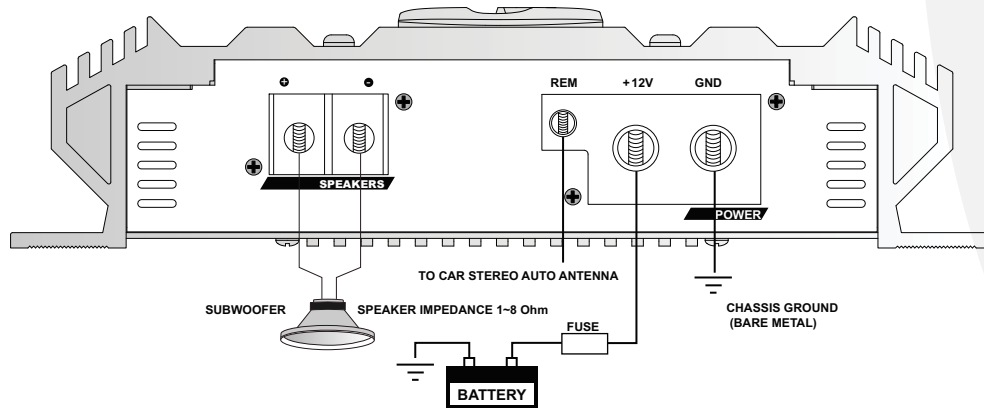

VIBE1801D

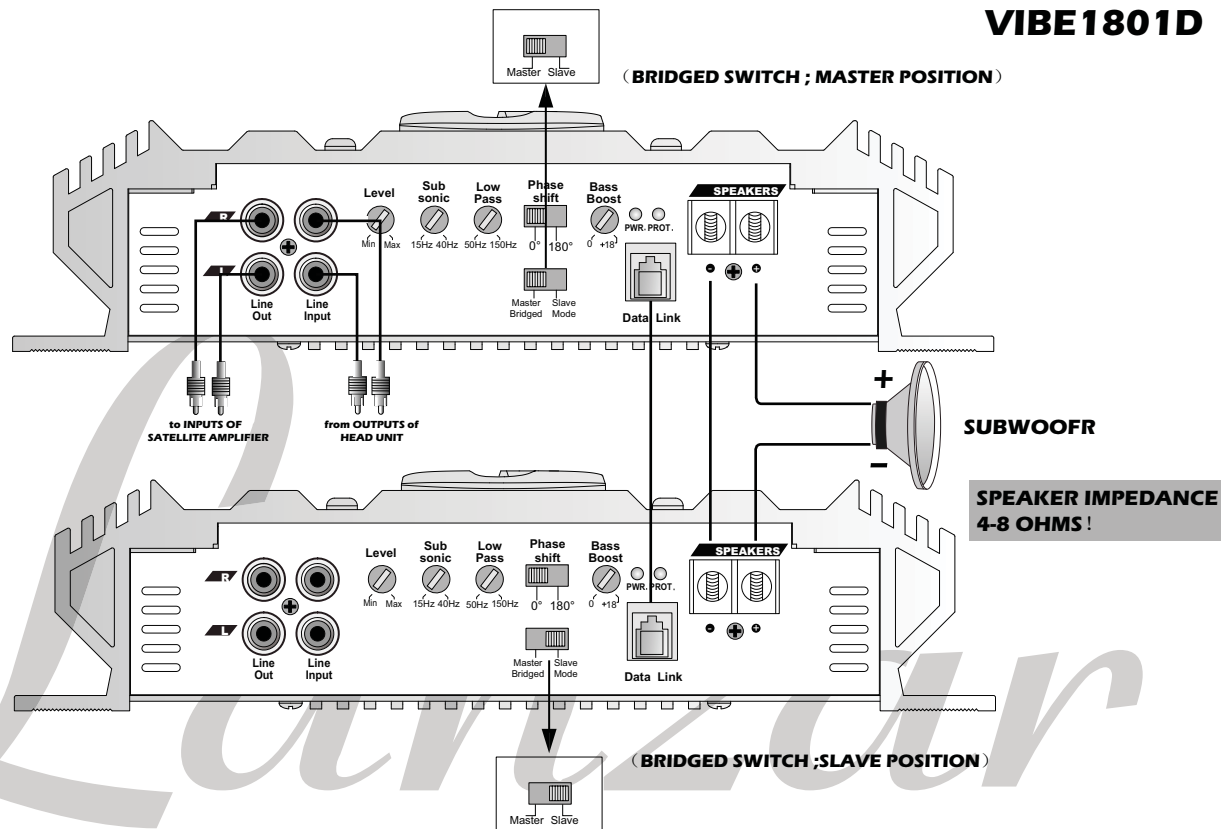

BRIDGING TWO AMPLIFIERS

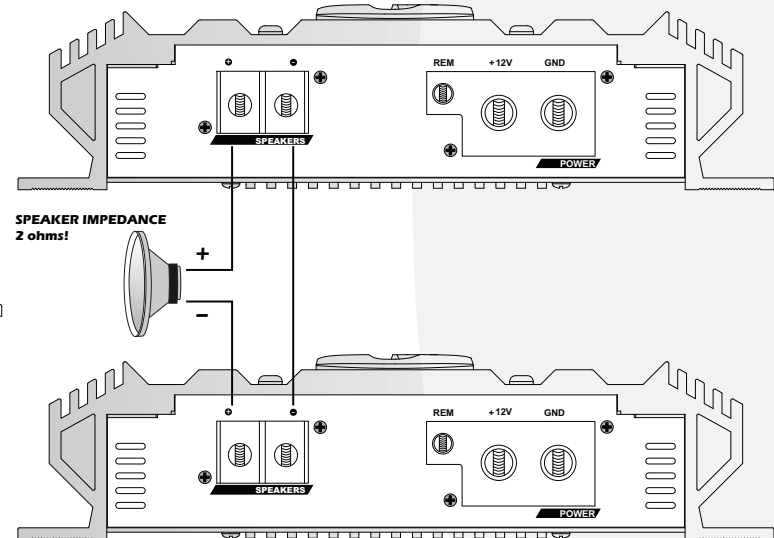
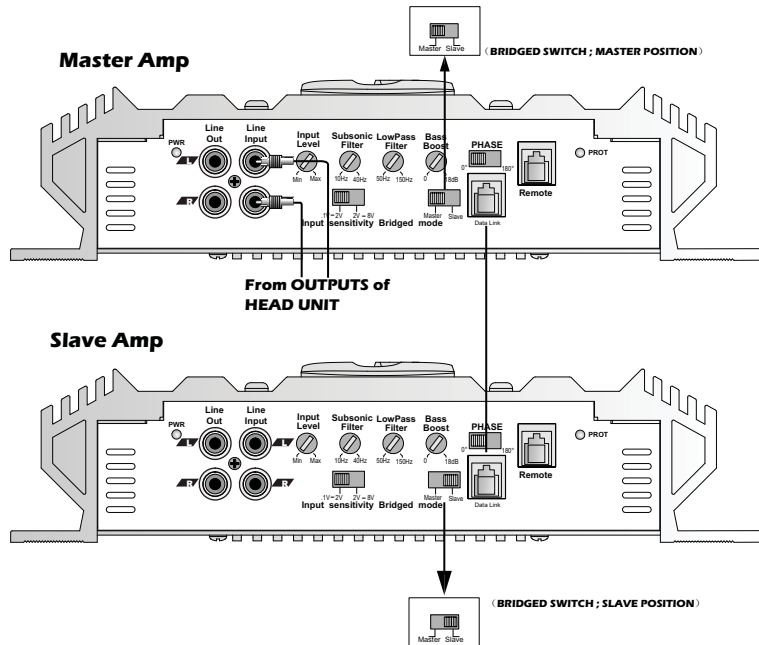

Bridging two amplifiers can be done only between two amplifiers of the same model number.

TROUBLESHOOTING

Before removing your amplifier, refer to the list below and follow the suggested procedures. Always test the speakers and their wires first.

AMPLIFIER WILL NOT POWER UP.

Check for good ground connection.

Check that remote DC terminal has at least 13.8v DC.

Check that there is battery power on the +terminal.

Check all fuses.

Check that Protection LED is not lit. If it is lit, shut off amplifier briefly and then repower it.

HIGH HISS OR ENGINE NOISE (ALTERNATOR WHINE) IN SPEAKERS.

Disconnect all RCA inputs to the amplifier(s)-if hiss / noise disappears, then plug in the component driving the amplifier and unplug its inputs. If hiss / noise disappears, go on until the faulty /noisy component is found.

It is best to set the amplifier's input level as insensitive as possible. The best subjective S/N ratio is obtainable this way. Try to drive as high a signal level from the head unit as possible.

PROTECTION LED COMES ON WHEN THE AMPLIFIER IS POWERED UP .

Check for shorts on speaker leads.

Check that the volume control on the head unit is turned down low.

Remove speaker leads, and reset the amplifier. If the Protection LED still comes on, then the amplifier is faulty.

AMPLIFIER(S) GETS VERY HOT.

Check that the minimum speaker impedance for that model is correct.

Check for speaker shorts.

Check that there is good airflow around the amplifier. In some applications, an external cooling fan may be required.

DISTORTED SOUND

Check that the Level control(s) is set to match the signal level of the head unit.

Check that all crossover frequencies have been properly set.

Check for shorts on the speaker leads.

HIGH SQUEAL NOISE FROM SPEAKERS.

This is always caused by a poorly-grounded RCA patch cord.

The logo features the word "Lanzar" in a white, cursive script font with a black outline, positioned above the word "vibe" in a large, bold, white, sans-serif font with a black outline. A thick orange swoosh curves around the text. The background is a colorful, abstract, textured pattern of blues, greens, and oranges.

Lanzar[®]
vibe

WWW.LANZAR.COM

1600 63rd Street • Brooklyn N.Y. 11204 • 718 535 - 1800 • FAX: 718 236-2400

Free Manuals Download Website

<http://myh66.com>

<http://usermanuals.us>

<http://www.somanuals.com>

<http://www.4manuals.cc>

<http://www.manual-lib.com>

<http://www.404manual.com>

<http://www.luxmanual.com>

<http://aubethermostatmanual.com>

Golf course search by state

<http://golfingnear.com>

Email search by domain

<http://emailbydomain.com>

Auto manuals search

<http://auto.somanuals.com>

TV manuals search

<http://tv.somanuals.com>