

CleanWave

18÷280 kVA

Installation and user manual

English



THE UNINTERRUPTIBLE POWER PROVIDER

MGE
UPS SYSTEMS

INDEX

1. INTRODUCTION	3
2. PRESENTATION	3
2.1. General presentation.....	3
2.2. Range.....	5
2.3. Technical specifications	6
3. SAFETY	7
3.1. Integration in housing.....	7
3.2. Cooling	7
3.3. Electrical connections	7
3.4. Access to the filter	7
4. ELECTRICAL ENGINEERING	8
4.1. Electrical schematic	8
4.2. Electrical protections	8
4.3. Wiring	8
5. INSTALLATION AND STARTING	9
5.1. Handling.....	9
5.2. Electrical connections	9
5.3. Energising	10
6. MAINTENANCE	11
7. TROUBLESHOOTING	12
8. CONTACT	12

1. INTRODUCTION

The present document is a user manual for the zero-sequenced filters CleanWave®.

It is intended to the persons responsible for the installation, the use and the maintenance of the filters. Each of these aspects is detailed in a specific chapter here under.

2. PRESENTATION

2.1. GENERAL PRESENTATION

The CleanWave® filter exists in 2 versions :

- IP00 : Basic version to be integrated by the customer.
- IP21 : "Turn-key" version integrated in its housing.

The IP00 version of the Cleanwave® filter appears as follows:

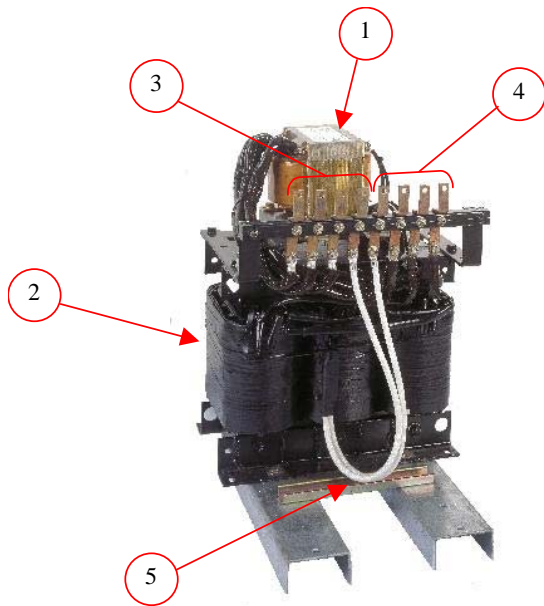

Fig. 1

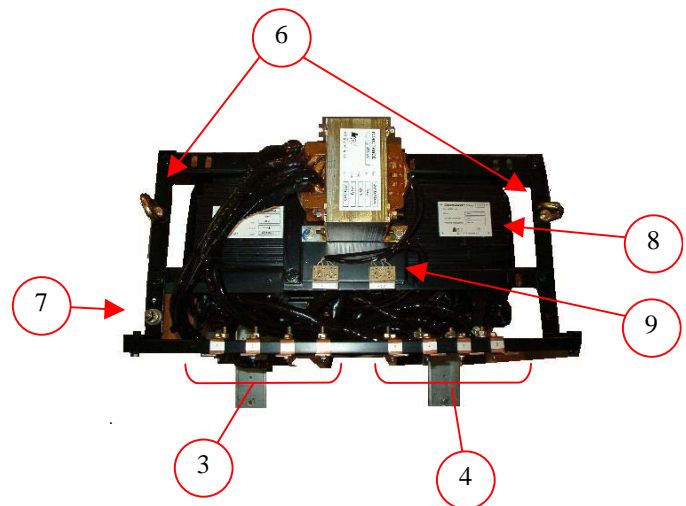

Fig. 2

1	Lo element
2	Zo element
3	Upstream (mains) terminals (1 - 4)
4	Downstream (load) terminals (5 - 8)
5	Fixation for optional current transformer for upstream and downstream neutral current measurements
6	Lifting rings
7	Earth terminal
8	Identification plate
9	Temperature switches terminals

The IP21 version of the CleanWave® filter appears as follows :

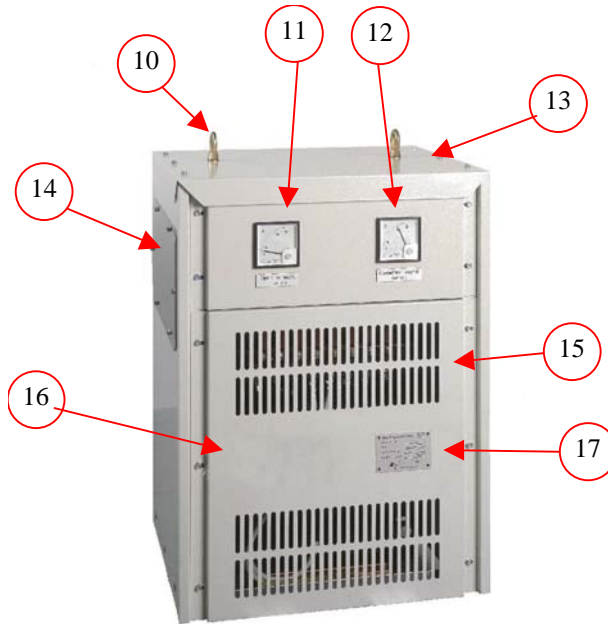

Fig. 3

10	Lifting rings
11	Upstream current display
12	Downstream current display
13	Removable top panel
14	Side panel for cabling
15	Ventilation grid
16	Removable front panel
17	Identification plate

Inside the housing, the filter is identical to the IP00 version shown on Fig. 1.

2.2. RANGE

The following table summarises the characteristics of the different products of the range (at 400V, 50/60Hz).

TYPE	Power.	I _{phase} max	I _{neutral} Max	Total losses max	Minimum sections ¹			
					Phases	Neutral (N)	Earth (PE)	(PEN ²)
	[kVA]	[A]	[A]	[W]	[mm ²]	[mm ²]	[mm ²]	[mm ²]
CleanWave-18	18	24	43	219	4	10	4	10
CleanWave-30	30	40	72	359	10	25	10	25
CleanWave-40	40	56	101	452	16	35	16	35
CleanWave-55	55	80	144	538	25	2x 25	16	2x 25
CleanWave-90	90	128	231	616	50	2x 50	25	2x 50
CleanWave-140	140	201	361	972	95	2x 95	50	2x 95
CleanWave-180	180	264	476	1212	150	2x 150	95	2x 150
CleanWave-220	220	321	577	1565	2x 95	2x 185	95	2x 185
CleanWave-280	280	401	722	1568	2x 95	2x 240	95	2x 240

Table 4

¹ According to European standards

² If common conductor for neutral and earth (PEN conductor)

2.3. TECHNICAL SPECIFICATIONS

Standards

Construction and safety :	IEC-60439-1
Conception :	IEC-60289, IEC-60727

IP rating

Unprotected :	IP00
Protected :	IP21

Electrical specifications

Frequency :	50 / 60Hz
Nominal voltage between phases :	400V +15% / -10%

Reduction ratio $\frac{I_{Neutral\ upstream}}{I_{Neutral\ downstream}}$	1:10
---	------

Ratio $\frac{I_{Neutral}}{I_{Phase}}$:	≤ 1.8
---	------------

Inrush current :	$\leq I_{nominal}$
Overload capacity :	10% - 1 hour 25% - 10 minutes 50% - 2 minutes
Insulation class :	1.1 kV
Dielectric strength :	3 kV
Thermal class of insulation:	H

Environmental conditions

Maximum ambient temperature :	50°C
Maximum altitude :	1000m
Maximum relative humidity :	90% without condensation

Please contact your MGE UPS SYSTEMS correspondent for different operating conditions.

→ www.mgeups.com

3. SAFETY



CAUTION !!! The CleanWave® filter exhibits potentially **lethal** voltages.

Like any electrical equipment, the installation and the use of the CleanWave® require some basic **precautions**.

3.1. INTEGRATION IN HOUSING

The IP00 filters are intended to be integrated by the customer. They must be integrated by **qualified electricians** in a housing or electrical cabinet guaranteeing the safety of the users according to regulations, standards and rules of application in the corresponding country (Protection rating must be at least IP20).

The IP21 version of the CleanWave® filter is already integrated in its housing and represents no danger for people. It is **forbidden to dismount** the enclosure while the filter is energised.

3.2. COOLING

Though well the CleanWave® filter has an excellent efficiency, its losses must be dissipated. The maximum total losses in standard conditions are given in table 4.

In the case of the IP21 version, the integrator must ensure that the **ventilation grids** on the front and rear sides of the filter **are not obstructed**. A minimum distance of **100mm** must be free on both sides of the housing. The **ambient temperature** should not exceed the maximum tolerated value (as a standard, **50°C** without de-rating).

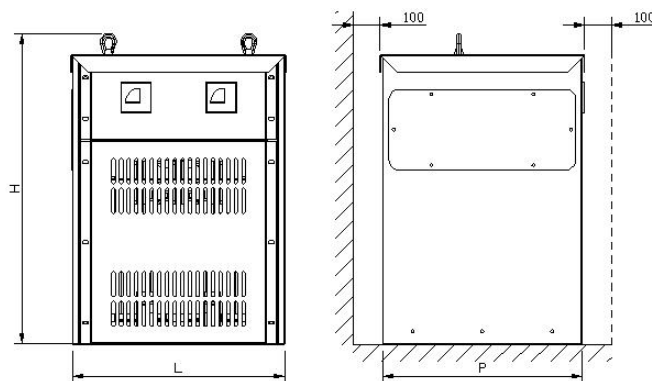

In the case of the IP00 version, it is the integrator 's responsibility to ensure a correct dissipation of the losses given in table 4.

3.3. ELECTRICAL CONNECTIONS

The cabling of the CleanWave® filter must be done with **no voltage** and by a **qualified technician**.

It is critical to respect the instructions given below as regards **minimum wiring sections** and **electrical protections**. Some local regulations, particularities of the electrical installation or specific rules may however impose the use of bigger sections.

The earth terminal of the filter must be properly connected to the earth of the installation, in respect of the minimum recommended sections.

3.4. ACCESS TO THE FILTER

The inside of the filter can only be accessed by **qualified electricians** and only with **no voltage**.

4. ELECTRICAL ENGINEERING

The electrical study for the implementation of a CleanWave[®] filter is very easy. The few instructions described in this document must however be respected in order to ensure the safety and efficiency of the system.

4.1. ELECTRICAL SCHEMATIC

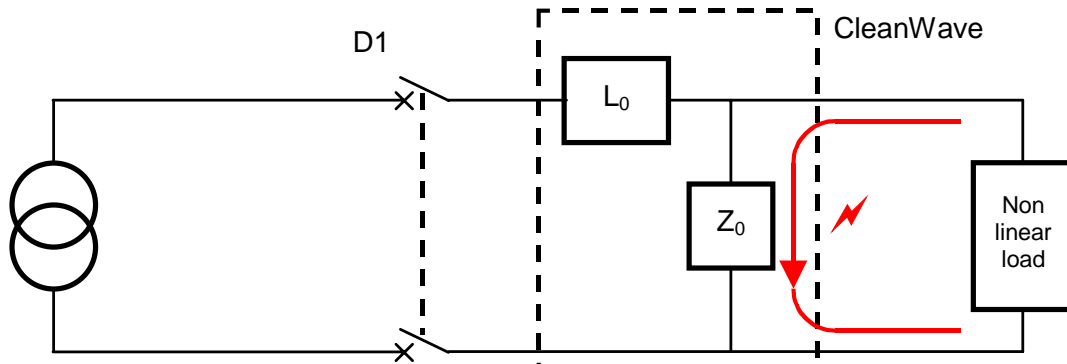

Fig. 6

In order to minimise the disturbing currents in the installation, the CleanWave[®] filter should be placed close to the disturbing load.

4.2. ELECTRICAL PROTECTIONS

The CleanWave[®] filter must be protected in a similar way as a transformer.

As a standard rule, the electrical protection D1 must be a **tetrapolar circuit breaker** (3 phases + neutral) with **neutral over-current detection**.

If such a protection is not possible (e.g. when the neutral and earth connectors are common (**PEN**)), a tripolar breaker will be used and the **PEN conductor section will be doubled**, as recommended in table 4.

The breakers must be selected according to the **phase current** as given in table 4 here above. The maximum inrush current is lower or equal to the nominal current and doesn't require particular precautions.

4.3. WIRING

The minimum recommended wiring sections for the different connectors are given in table 4. These are minimum recommendations according to the European regulations. Higher sections may be used according to local regulations, particularities of the electrical installation or specific rules.

The **neutral conductor** may be crossed by a current up to 1.8 times the phase current and is therefore **over-sized**.



5. INSTALLATION AND STARTING

5.1. HANDLING

The filters are delivered on a wooden tray and can easily be moved with the help of a forklift. They can also be handled with the help of the lifting rings.

5.2. ELECTRICAL CONNECTIONS

*The electrical connections must be done with **no voltage** by a **qualified electrician**.*

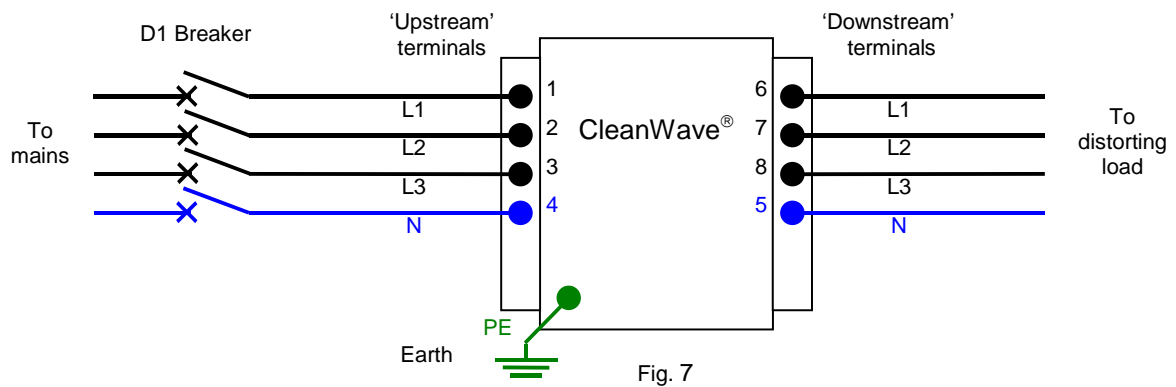

The power connections (see fig. 1 et 2) are done on the upstream (3) and downstream (4) terminals.

For IP21 CleanWave® filters (see fig. 3), access to the terminals is possible either by removing, **without voltage**, the top panel (13), or the lower part of the front panel (16). The cables can be entered either from the bottom of the cabinet or through one of the side panels (17).



Fig. 8

The connections are the following :

Terminal	Connection
1	L1 upstream
2	L2 upstream
3	L3 upstream
4	N upstream
5	N downstream
6	L1 downstream
7	L2 downstream
8	L3 downstream
Earth	Earth (PE)

Table 9

The terminals must be properly tightened according to the size of the bolts.

Temperature switches are optionally foreseen on both the Lo and Zo elements for the detection of a possible over-heating. In that case, for each element, two voltage-free contacts are available :

Terminals	Connection
A1 - A2	Normally open contact 'Warning' (165°C)
D1 - D2	Normally closed contact 'Alarm' (190°C)

Table 10

These contacts are connected on two small terminal boards (Fig. 2 - "9").
They are foreseen for a maximum current of 5A and a maximum voltage of 230V AC.

5.3. ENERGISING



For obvious safety reasons, the energising of the filter can only happen once ***the housing is perfectly secured.***

During the energising of the filter, the loads downstream the CleanWave® filter will also be fed. It is the technician's responsibility to check ***that the downstream installation can safely be energised.***

Once the filter energised, the displays on the front side (IP21 version only) should indicate some upstream and downstream currents.

6. MAINTENANCE

After installation, the CleanWave[®] filter requires almost no maintenance. We only recommend a periodic (e.g. annual) inspection.

This inspection must be done **with no voltage** by a **qualified technician**.

The working sequence is the following :

- Switch off the power of the CleanWave[®] filter.
- Open the housing in order to access the filter. In the case of the IP21 CleanWave[®] filter,
 - Unscrew and remove the lower part of the front panel (see fig. 3 and 7).
 - **Check that there is no voltage** on the terminals.
- Visually check the general aspect of the filter, especially that there is no excessive dust on the Lo and Zo chokes.
- If necessary, clean the Lo and Zo with compressed air or with a vacuum-cleaner.
- Check the tightening of the power terminals.
- Close the housing.
- Power up the filter.

7. TROUBLESHOOTING

Malfunction	Solution
No neutral current is measured downstream the filter.	<ul style="list-style-type: none"> • Is the filter energised ? • Is breaker D1 closed ? • Is the filter feeding the distorting load ?
No neutral current is measured upstream the filter.	<ul style="list-style-type: none"> • The CleanWave[®] filter reduces the neutral current by 10, approximately. It can happen that the remaining value is too low and is not measurable.
Tripping of the 'Warning' temperature sensor of one of the chokes (Lo or Zo) (<i>option</i>).	<ul style="list-style-type: none"> • Temperature of the element has reached 165°C • The load must be reduced in order to avoid overheating of the filter. • Check that the phase and neutral currents respect the limits given in table 4. • Check that the ventilation grids (front and rear) are not obstructed. • Check that the Lo and Zo elements are not covered with dust. • Isn't the ambient temperature excessive (standard : 50°C) ?
Tripping of the "Alarm" temperature sensor of one of the chokes (Lo or Zo) (<i>option</i>).	<ul style="list-style-type: none"> • Temperature of the element has reached 190°C • Danger ! The filter must immediately be switched off.

Table 11

If the observed malfunction is not in this list or if the problem remains after applying the recommended solutions, please contact MGE UPS SYSTEMS to the address below.

8. CONTACT

For any assistance or complementary information, please contact your local distributor MGE UPS SYSTEMS. You will find his details on the website www.mgeups.com .

MGE UPS SYSTEMS

THE UNINTERRUPTIBLE POWER PROVIDER

140, Avenue Jean Kuntzmann
ZIRST - Montbonnot St Martin
38334 - Saint Ismier Cedex - France
www.mgeups.com



Free Manuals Download Website

<http://myh66.com>

<http://usermanuals.us>

<http://www.somanuals.com>

<http://www.4manuals.cc>

<http://www.manual-lib.com>

<http://www.404manual.com>

<http://www.luxmanual.com>

<http://aubethermostatmanual.com>

Golf course search by state

<http://golfingnear.com>

Email search by domain

<http://emailbydomain.com>

Auto manuals search

<http://auto.somanuals.com>

TV manuals search

<http://tv.somanuals.com>