



OPERATING INSTRUCTIONS

MODEL : MPH692



HANDSFREE SPEAKER PHONE With CALLER ID

*Requires 4 "AAA" batteries (not included)

*To operate the Caller ID features, you must subscribe to the CALLER ID services offered by your local phone company

IMPORTANT SAFETY INSTRUCTIONS

When using your telephone equipment, basic safety precautions should always be followed to reduce the risk of fire, electric shock and injury to persons, including the following :

1. Do not use this product near water, for example, near a bath tub, wash bowl, kitchen sink, or laundry tub, in a wet basement or near a swimming pool.
2. Avoid using a telephone (other than a cordless type) during an electrical storm. There may be a remote risk of electric shock from lightning.
3. Do not use the telephone to report a gas leak in vicinity of the leak.
4. Use only the power cord and batteries indicated in this manual. Do not dispose of batteries in a fire. They may explode. Check with local codes for possible special disposal instructions.

SAVE THESE INSTRUCTIONS

Consumer Information:

This equipment complies with Part 68 of the FCC rules and the requirements adopted by the ACTA. On the *bottom* of this equipment is a label that contains, among other information, a product identifier in the format *US:AAAEQ##TXXXX*. If requested, this number must be provided to the telephone company.

An applicable certification jacks Universal Service Order Codes (USOC) for the equipment is provided (i.e., *RJ11C*) in the packaging with each piece of approved terminal equipment.

A plug and jack used to connect this equipment to the premises wiring and telephone network must comply with the applicable FCC Part 68 rules and requirements adopted by the ACTA. A compliant telephone cord and modular plug is provided with this product. It is designed to be connected to a compatible modular jack that is also compliant. See installation instructions for details.

The REN is used to determine the number of devices that may be connected to a telephone line. Excessive RENs on a telephone line may result in the devices not ringing in response to an incoming call. In most but not all areas, the sum of RENs should not exceed five (5.0). To be certain of the number of devices that may be connected to a line, as determined by the total RENs, contact the local telephone company. [For products approved after July 23, 2001, the REN for this product is part of the product identifier that has the format *US:AAAEQ##TXXXX*. The digits represented by *##* are the REN without a decimal point (e.g., 03 is a REN of 0.3). For earlier products, the REN is separately shown on the label.]

If this telephone causes harm to the telephone network, the telephone company will notify you in advance that temporary discontinuance of service may be required. But if advance notice isn't practical, the telephone company will notify the customer as soon as possible. Also, you will be advised of your right to file a complaint with the FCC if you believe it is necessary.

The telephone company may make changes in its facilities, equipment, operations or procedures that could affect the operation of the equipment. If this happens the telephone company will provide advance notice in order for you to make necessary modifications to maintain uninterrupted service.

Please follow instructions for repairing if any (e.g. battery replacement section); otherwise do not alternate or repair any parts of device except specified.

Connection to party line service is subject to state tariffs. Contact the state public utility commission, public service commission or corporation commission for information.

This equipment is hearing aid compatible.

NOTICE: If your home has specially wired alarm equipment connected to the telephone line, ensure the installation of this telephone does not disable your alarm equipment. If you have questions about what will disable alarm equipment, consult your telephone company or a qualified installer.

Should you experience trouble with this equipment, please contact **Memorex** for repair or warranty information. If the equipment is causing harm to the telephone network, the telephone company may request that you disconnect the equipment until the problem is resolved.

[NOTICE: According to telephone company reports, AC electrical surges, typically resulting from lightning strikes, are very destructive to telephone equipment connected to AC power sources. To minimize damage from these types of surges, a surge arrestor is recommended.]

[To comply with state tariffs, the telephone company must be given notification prior to connection for customer-owned coin or credit card phone. In some states, the state public utility commission, public service commission or corporation commission must give prior approval of connection.]

FEATURES

The Caller ID Speakerphone incorporates 70 name and number caller ID memories as well as convenient user features into a single line telephone.

Caller ID Features Include :

- Displays Caller's name and number as well as time and date of the call. *
- Displays Total Calls as well as Total New Calls in Standby Screen.
- Call Review in Dual Direction (Up & Down)
- Real Time Clock displays Time and Date as well as the length of the call.
- 3 Language operation (English, French, Spanish) selectable.
- Stores the Call information for the last 70 calls that you have received.
- DELETE button can selectively or collectively erase stored calls.

Telephone User Features Include :

- Handsfree speakerphone
- LCD display dialing.
- 10 Programmable Auto Dial Numbers
- Hi / Lo Volume Control
- On / Off ringer sound level select switch.
- Flash button is used to pick up additional incoming calls while in use.

Important Note : If you don't have call waiting service from your local telephone company, FLASH button will disconnect the current call.

- Tone / Pulse dialing select switch.
- Redial button allows user to redial the last number dialed.
- Pause button for advanced calling features
- Desk or wall mountable.

*REQUIRES SERVICE FROM YOUR LOCAL TELEPHONE COMPANY

LOCATION OF CONTROLS

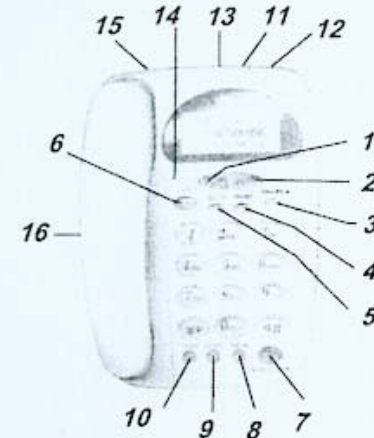

- | | |
|------------------------------------|----------------------------|
| 1. UP Review button | 11. TONE - PULSE switch |
| 2. DOWN Review button | 12. Hi / Lo Volume switch |
| 3. CALL BACK button | 13. On / Off Ringer switch |
| 4. PAUSE button | 14. NEW CALL LED |
| 5. DELETE button | 15. LINE CORD JACK |
| 6. AUTO button | 16. HANDSET JACK |
| 7. HANDSFREE (SPEAKERPHONE) button | |
| 8. REDIAL button | |
| 9. FLASH button | |
| 10. STORE button | |

INSTALLATION

BATTERY INSTALLATION

Insert four 1.5V 'AAA' batteries for the LCD display (**Batteries not included**).

1. Remove the battery cover from the back of your phone.
2. Insert four 1.5V 'AAA' size batteries into the compartment.
3. Replace the battery cover.

NOTE : The batteries need to be replaced regularly. If phone is not in use remove the batteries.

DESK INSTALLATION

1. Install one end of the handset coiled cord into the handset modular jack.
2. Install the remaining end of the handset coiled cord into the handset jack

- located on the left side of the telephone.
- Place the handset into the cradle.
 - Connect one end of the telephone line cord into the telephone jack.
 - Connect the remaining end of the telephone line into a nearby telephone jack.

WALL INSTALLATION

The unit can be mounted to any wall surface using two self-tapping screws (not included), by following these instructions.

- The handset hanger tab is shipped in the desk use position. Please slide the tab out and rotate it 180 degrees. See Figure 1



Figure 1

- Install the two self-tapping screws at a distance of 3-29/32 inches (100mm) from each other and located on a vertical center line. See Figure 2
- Tighten each screw just enough to allow the wall mounting holes enough clearance to slip snugly over each screw head.
- Install the wall mounting bracket to the unit. See Figure 3

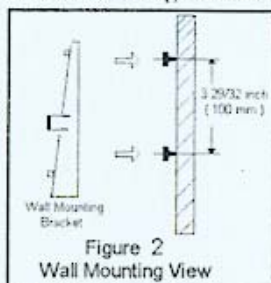

Figure 2
Wall Mounting View

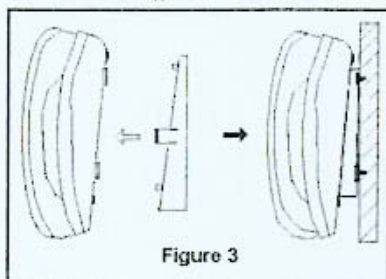

Figure 3

- Connect one end of the telephone line cord into the unit line jack. Connect the remaining end of the telephone line cord into a nearby telephone jack

OPERATION FOR TELEPHONE

1. Tone / Pulse switch

Please ask your local telephone company whether your phone service is PULSE (Rotary) dialing or TONE dialing. Set the switch at TONE position for TONE type, or set the switch at PULSE position for PULSE (Rotary) type.

2. Ringer select switch

Set the ringer switch to the desired setting. (ON-OFF).

3. REDIAL button

This feature allows you to redial the last number you have called.

4. FLASH button

Press FLASH button to terminate a call and institute a dial tone for another call or get another call from "Call Waiting". (a special telephone service)

NOTE: If you do not have any special telephone service, such as Call Waiting, pressing the FLASH button during a call may disconnect your current conversation.

If you do not know which system is in use, consult your telephone company for help.

5. PAUSE button

Allows you to insert a 4 second pause before automatically dialing an extension.

6. USE AS A MEMORY PHONE (16 digits can be stored in a speed dialing code)

- Lift the "Handset" or press "HANDSFREE" Key
- Press "STORE" key once.
- Enter the telephone number you want to store
- Press "STORE" key once again
- Enter desired location number from 0 to 9 button

7. DIAL A NUMBER FROM MEMORY

- Lift the "Handset" or press "Handsfree" key, listen for a dial tone
- Press the "AUTO" key
- Enter desired location number code (0-9)

OPERATION FOR CALLER ID

IMPORTANT: subscription to Caller ID service from your local phone company is required before initial use of Caller ID feature.

SETTING THE LANGUAGE MODE AREA CODE AND TIME / DATE

After applying power for the first time, the display will show:

E F S
SET LANGUAGE

"SET LANGUAGE" will appear on the LCD display and the letter "E" will flash. You are advised to select the language mode by the following.

- Press either one of the UP or DOWN buttons to select desired language. E (ENGLISH), F (French), S (Spanish).
- Once the desired language is selected, press DELETE button to confirm selection.
- You must now set the area code. Press the DOWN button to increase the number in the sequence.
- Press DELETE to shift to the next digit, then press DOWN to increase the number in sequence.
- When you have finished setting the area code, press DELETE; you must now set the clock and date. The hour icon will be blinking

12:00PM 1/01

SET TIME / DATE

- Press the UP or DOWN button to set the current hour.
- Press the DELETE button to shift to the minute setting.
- Press the UP or DOWN button to set the current minute.
- Press the DELETE button to shift to the month setting.
- Press the UP or DOWN button to set the current month.

11. Press the DELETE button to shift to the date setting.
12. Press the UP or DOWN button to set the current date.
13. Once the correct time / date is shown on the display, press the DELETE button to end the setting; the display will change to show the normal status.

CHANGE THE LANGUAGE MODE, TIME / DATE

1. Press and hold the DELETE button, then press the UP button.
2. The unit will enter the language setting.
3. Follow steps 1 – 10 described in section of "SETTING THE LANGUAGE MODE AND TME / DATE".

A Caller ID Record consists of the following information :



INCOMING CALLS DISPLAY : The unit can display calling numbers and keep the date & time of the call.

TOTAL CALLS DISPLAY : In the state of on-hook, the LCD will show total calls of the call display. The unit can store up to 70 call records.

NEW CALLS : If there are any new calls in memory, the NEW icon will turn on and the LED indicator will flash to draw your attention. After all the calls have been reviewed, the new call LED will stop flashing.

OUT OF AREA : The LCD will show "OUT OF AREA", when the Call Identification Service is not available in this area.

PRIVATE : If the caller has exercised the option to prevent his number from being sent, the "BLOCKED CALL" will be shown on the screen.

DELETE CALLS : Press DELETE button twice within 1.5 seconds to erase the individual call. Press and hold the DELETE button for 6 seconds to delete all the numbers or clear the memory, the LCD will then show "NO CALL".

REVIEW CALLS : The UP and DOWN button can be used to review the call history. When you reach the end of the call history list, the LCD will show "END OF LIST". If there is no call, then LCD shows "NO CALL".

BATTERY LOW INDICATOR : If the battery is running low, the battery low icon will turn on. ^(LOW)

Using the CALL BACK feature

Allows you to automatically dial the number of the person who has called previously.

- a. Lift the handset or press the "HANDSFREE" Key and listen for a dial tone.
- b. Select the caller that you want to call back by pressing the UP or DOWN button.
- c. Press CALL BACK button to automatically dial the phone number of the caller shown on the LCD panel.

NOTE :

The Call Back feature will not dial the phone number if the selected phone number is blocked or if it is not available.

For additional set-up or operating assistance, please visit our website at www.memcorpinc.com or contact customer service at **PHONE:(800) 919-3647**

Please keep all packaging material for at least 90 days in case you need to return this product to your place of purchase or MEMOREX.

For parts and accessories, contact FOX INT'L at 1-800-321-6993

Memcorp Inc
3200 Meridian Parkway
Weston, FL 33331, USA



OPERATING INSTRUCTIONS

MODEL : MPH692



HANDSFREE SPEAKER PHONE With CALLER ID

***Requires 4 "AAA" batteries (not included)**

***To operate the Caller ID features, you must subscribe to the
CALLER ID services offered by your local phone company**

IMPORTANT SAFETY INSTRUCTIONS

When using your telephone equipment, basic safety precautions should always be followed to reduce the risk of fire, electric shock and injury to persons, including the following :

1. Do not use this product near water, for example, near a bath tub, wash bowl, kitchen sink, or laundry tub, in a wet basement or near a swimming pool.

2. Avoid using a telephone (other than a cordless type) during an electrical storm. There may be a remote risk of electric shock from lightning.

3. Do not use the telephone to report a gas leak in vicinity of the leak.

4. Use only the power cord and batteries indicated in this manual. Do not dispose of batteries in a fire. They may explode. Check with local codes for possible special disposal instructions.

SAVE THESE INSTRUCTIONS

Consumer Information:

This equipment complies with Part 68 of the FCC rules and the requirements adopted by the ACTA. On the *bottom* of this equipment is a label that contains, among other information, a product identifier in the format *US:AAAEQ##TXXXX*. If requested, this number must be provided to the telephone company.

An applicable certification jacks Universal Service Order Codes (USOC) for the equipment is provided (i.e., *RJ11C*) in the packaging with each piece of approved terminal equipment.

A plug and jack used to connect this equipment to the premises wiring and telephone network must comply with the applicable FCC Part 68 rules and requirements adopted by the ACTA. A compliant telephone cord and modular plug is provided with this product. It is designed to be connected to a compatible modular jack that is also compliant. See installation instructions for details.

The REN is used to determine the number of devices that may be connected to a telephone line. Excessive RENs on a telephone line may result in the devices not ringing in response to an incoming call. In most but not all areas, the sum of RENs should not exceed five (5.0). To be certain of the number of devices that may be connected to a line, as determined by the total RENs, contact the local telephone company. [For products approved after July 23, 2001, the REN for this product is part of the product identifier that has the format *US:AAAEQ##TXXXX*. The digits represented by ## are the REN without a decimal point (e.g., 03 is a REN of 0.3). For earlier products, the REN is separately shown on the label.]

If this telephone causes harm to the telephone network, the telephone company will notify you in advance that temporary discontinuance of service may be required. But if advance notice isn't practical, the telephone company will notify the customer as soon as possible. Also, you will be advised of your right to file a complaint with the FCC if you believe it is necessary.

The telephone company may make changes in its facilities, equipment, operations or procedures that could affect the operation of the equipment. If this happens the telephone company will provide advance notice in order for you to make necessary modifications to maintain uninterrupted service.

Please follow instructions for repairing if any (e.g. battery replacement section); otherwise do not alternate or repair any parts of device except specified.

Connection to party line service is subject to state tariffs. Contact the state public utility commission, public service commission or corporation commission for information.

This equipment is hearing aid compatible.

NOTICE: If your home has specially wired alarm equipment connected to the telephone line, ensure the installation of this telephone does not disable your alarm equipment. If you have questions about what will disable alarm equipment, consult your telephone company or a qualified installer.

Should you experience trouble with this equipment, please contact **Memorex** for repair or warranty information. If the equipment is causing harm to the telephone network, the telephone company may request that you disconnect the equipment until the problem is resolved.

[NOTICE: According to telephone company reports, AC electrical surges, typically resulting from lightning strikes, are very destructive to telephone equipment connected to AC power sources. To minimize damage from these types of surges, a surge arrestor is recommended.]

[To comply with state tariffs, the telephone company must be given notification prior to connection for customer-owned coin or credit card phone. In some states, the state public utility commission, public service commission or corporation commission must give prior approval of connection.]

FEATURES

The Caller ID Speakerphone incorporates 70 name and number caller ID memories as well as convenient user features into a single line telephone.

Caller ID Features Include :

- Displays Caller's name and number as well as time and date of the call. *
- Displays Total Calls as well as Total New Calls in Standby Screen.
- Call Review in Dual Direction (Up & Down)
- Real Time Clock displays Time and Date as well as the length of the call.
- 3 Language operation (English, French, Spanish) selectable.
- Stores the Call information for the last 70 calls that you have received.
- DELETE button can selectively or collectively erase stored calls.

Telephone User Features Include :

- Handsfree speakerphone
- LCD display dialing.
- 10 Programmable Auto Dial Numbers
- Hi / Lo Volume Control
- On / Off ringer sound level select switch.
- Flash button is used to pick up additional incoming calls while in use.

Important Note : If you don't have call waiting service from your local telephone company, FLASH button will disconnect the current call.

- Tone / Pulse dialing select switch.
- Redial button allows user to redial the last number dialed.
- Pause button for advanced calling features
- Desk or wall mountable.

***REQUIRES SERVICE FROM YOUR LOCAL TELEPHONE COMPANY**

LOCATION OF CONTROLS

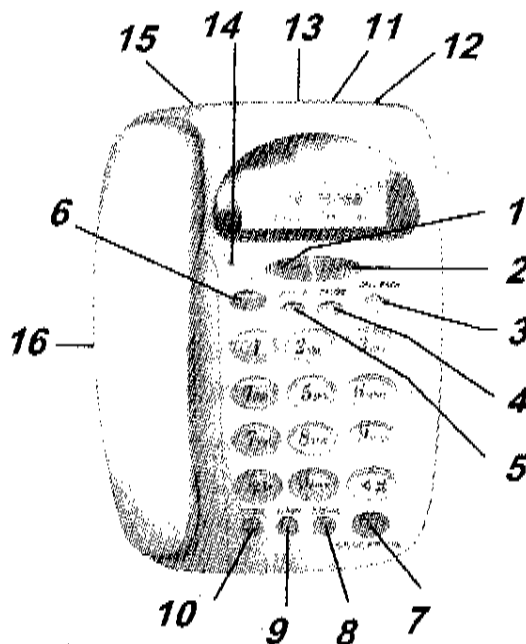

- | | |
|------------------------------------|----------------------------|
| 1. UP Review button | 11. TONE - PULSE switch |
| 2. DOWN Review button | 12. Hi / Lo Volume switch |
| 3. CALL BACK button | 13. On / Off Ringer switch |
| 4. PAUSE button | 14. NEW CALL LED |
| 5. DELETE button | 15. LINE CORD JACK |
| 6. AUTO button | 16. HANDSET JACK |
| 7. HANDSFREE (SPEAKERPHONE) button | |
| 8. REDIAL button | |
| 9. FLASH button | |
| 10. STORE button | |

INSTALLATION

BATTERY INSTALLATION

Insert four 1.5V 'AAA' batteries for the LCD display (**Batteries not included**).

1. Remove the battery cover from the back of your phone.
2. Insert four 1.5V 'AAA' size batteries into the compartment.
3. Replace the battery cover.

NOTE : The batteries need to be replaced regularly. If phone is not in use remove the batteries.

DESK INSTALLATION

1. Install one end of the handset coiled cord into the handset modular jack.
2. Install the remaining end of the handset coiled cord into the handset jack

- located on the left side of the telephone.
- Place the handset into the cradle .
 - Connect one end of the telephone line cord into the telephone jack.
 - Connect the remaining end of the telephone line into a nearby telephone jack.

WALL INSTALLATION

The unit can be mounted to any wall surface using two self-tapping screws (not included), by following these instructions.

- The handset hanger tab is shipped in the desk use position. Please slide the tab out and rotate it 180 degrees. *See Figure 1*



Figure 1

- Install the two self-tapping screws at a distance of 3-29/32 inches (100mm) from each other and located on a vertical center line. *See Figure 2*
- Tighten each screw just enough to allow the wall mounting holes enough clearance to slip snugly over each screw head.
- Install the wall mounting bracket to the unit. *See Figure 3*

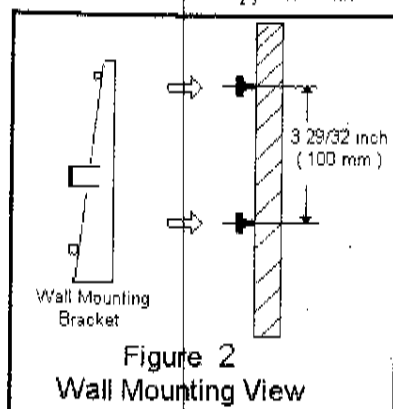

Figure 2

Wall Mounting View

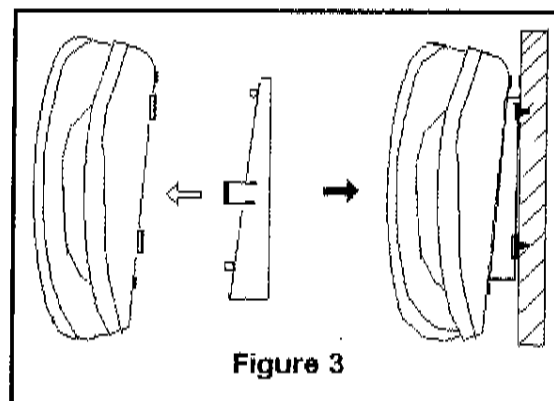

Figure 3

- Connect one end of the telephone line cord into the unit line jack. Connect the remaining end of the telephone line cord into a nearby telephone jack

OPERATION FOR TELEPHONE

1. Tone / Pulse switch

Please ask your local telephone company whether your phone service is PULSE (Rotary) dialing or TONE dialing. Set the switch at TONE position for TONE type, or set the switch at PULSE position for PULSE (Rotary) type.

2. Ringer select switch

Set the ringer switch to the desired setting. (ON-OFF).

3. REDIAL button

This feature allows you to redial the last number you have called.

4. FLASH button

Press FLASH button to terminate a call and institute a dial tone for another call or get another call from "Call Waiting". (a special telephone service)

NOTE : If you do not have any special telephone service, such as Call Waiting, pressing the FLASH button during a call may disconnect your current conversation.

If you do not know which system is in use, consult your telephone company for help.

5. PAUSE button

Allows you to insert a 4 second pause before automatically dialing an extension.

6. USE AS A MEMORY PHONE (16 digits can be stored in a speed dialing code)

- a. Lift the "Handset" or press "HANDSFREE" Key
- b. Press "STORE" key once.
- c. Enter the telephone number you want to store
- d. Press "STORE" key once again
- e. Enter desired location number from 0 to 9 button

7. DIAL A NUMBER FROM MEMORY

- Lift the "Handset" or press "Handsfree" key, listen for a dial tone
- Press the "AUTO" key
- Enter desired location number code (0-9)

OPERATION FOR CALLER ID

IMPORTANT: subscription to Caller ID service from your local phone company is required before initial use of Caller ID feature.

SETTING THE LANGUAGE MODE AREA CODE AND TIME / DATE

After applying power for the first time, the display will show:

E F S
SET LANGUAGE

"SET LANGUAGE" will appear on the LCD display and the letter "E" will flash. You are advised to select the language mode by the following.

1. Press either one of the **UP** or **DOWN** buttons to select desired language. E (ENGLISH), F (French), S (Spanish).
2. Once the desired language is selected, press **DELETE** button to confirm selection.
3. You must now set the area code. Press the **DOWN** button to increase the number in the sequence
4. Press **DELETE** to shift to the next digit, then press **DOWN** to increase the number in sequence
5. When you have finished setting the area code, press **DELETE**; you must now set the clock and date. The hour icon will be blinking

12:00PM 1/01

SET TIME / DATE

6. Press the **UP** or **DOWN** button to set the current hour.
7. Press the **DELETE** button to shift to the minute setting.
8. Press the **UP** or **DOWN** button to set the current minute.
9. Press the **DELETE** button to shift to the month setting.
10. Press the **UP** or **DOWN** button to set the current month.

11. Press the **DELETE** button to shift to the date setting.
12. Press the **UP** or **DOWN** button to set the current date.
13. Once the correct time / date is shown on the display, press the **DELETE** button to end the setting; the display will change to show the normal status.

CHANGE THE LANGUAGE MODE, TIME / DATE

1. Press and hold the **DELETE** button, then press the **UP** button.
2. The unit will enter the language setting.
3. Follow steps 1 - 10 described in section of "SETTING THE LANGUAGE MODE AND TME / DATE".

A Caller ID Record consists of the following information :

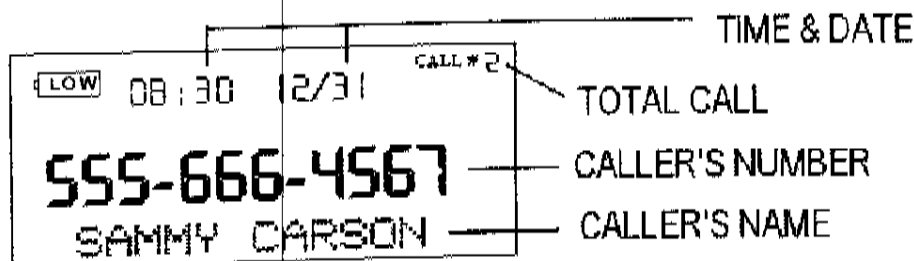

INCOMING CALLS DISPLAY : The unit can display calling numbers and keep the date & time of the call.

TOTAL CALLS DISPLAY : In the state of on-hook, the LCD will show total calls of the call display. The unit can store up to 70 call records.

NEW CALLS : If there are any new calls in memory, the **NEW** icon will turn on and the LED indicator will flash to draw your attention. After all the calls have been reviewed, the new call LED will stop flashing.

OUT OF AREA : The LCD will show "OUT OF AREA", when the Call Identification Service is not available in this area.

PRIVATE : If the caller has exercised the option to prevent his number from being sent, the "BLOCKED CALL" will be shown on the screen.

DELETE CALLS : Press **DELETE** button twice within 1.5 seconds to erase the individual call. Press and hold the **DELETE** button for 6 seconds to delete all the numbers or clear the memory, the LCD will then show "NO CALL".

REVIEW CALLS : The **UP** and **DOWN** button can be used to review the call history. When you reach the end of the call history list, the LCD will show "END OF LIST". If there is no call, then LCD shows "NO CALL".

BATTERY LOW INDICATOR : If the battery is running low, the battery low icon will turn on. LOW

Using the CALL BACK feature

Allows you to automatically dial the number of the person who has called previously.

- a. Lift the handset or press the "HANDSFREE" Key and listen for a dial tone.
- b. Select the caller that you want to call back by pressing the **UP** or **DOWN** button.
- c. Press **CALL BACK** button to automatically dial the phone number of the caller shown on the LCD panel.

NOTE :

The Call Back feature will not dial the phone number if the selected phone number is blocked or if it is not available.

For additional set-up or operating assistance, please visit our website at
www.memcorpinc.com or contact customer service at
PHONE:(800) 919-3647

Please keep all packaging material for at least 90 days in case you need to return
this product to your place of purchase or MEMOREX.

For parts and accessories, contact FOX INT'L at 1-800-321-6993

Memcorp Inc
3200 Meridian Parkway
Weston, FL 33331, USA

Free Manuals Download Website

<http://myh66.com>

<http://usermanuals.us>

<http://www.somanuals.com>

<http://www.4manuals.cc>

<http://www.manual-lib.com>

<http://www.404manual.com>

<http://www.luxmanual.com>

<http://aubethermostatmanual.com>

Golf course search by state

<http://golfingnear.com>

Email search by domain

<http://emailbydomain.com>

Auto manuals search

<http://auto.somanuals.com>

TV manuals search

<http://tv.somanuals.com>