

MOBILE AND STURDY.

Crosscut, Mitre and Table saws from Metabo offer the user the benefit of having three machines in one. The KGT 300 allows the user to crosscut timbers to length at 90° up to 120 mm in depth, then mitre all the way to 45° and cut up to 66 mm in depth. In table saw mode the machine is ideally suited to ripping panels up to

55 mm in depth, e.g. when cutting panels to size for laminate flooring. The KGT 501 is a larger version of this machine with a maintenance free induction motor, ideal for large timbers and on site use. Professional, precise and robust. **Metabo – the professionals brand.**

SAWS

SPECIAL-PURPOSE MACHINES

SYSTEMATIC ORGANISATION

GARDEN

WOOD-PROCESSING TECHNOLOGY

WATER-/PUMP TECHNOLOGY

WELDING TECHNOLOGY

COMPRESSED AIR SYSTEMS

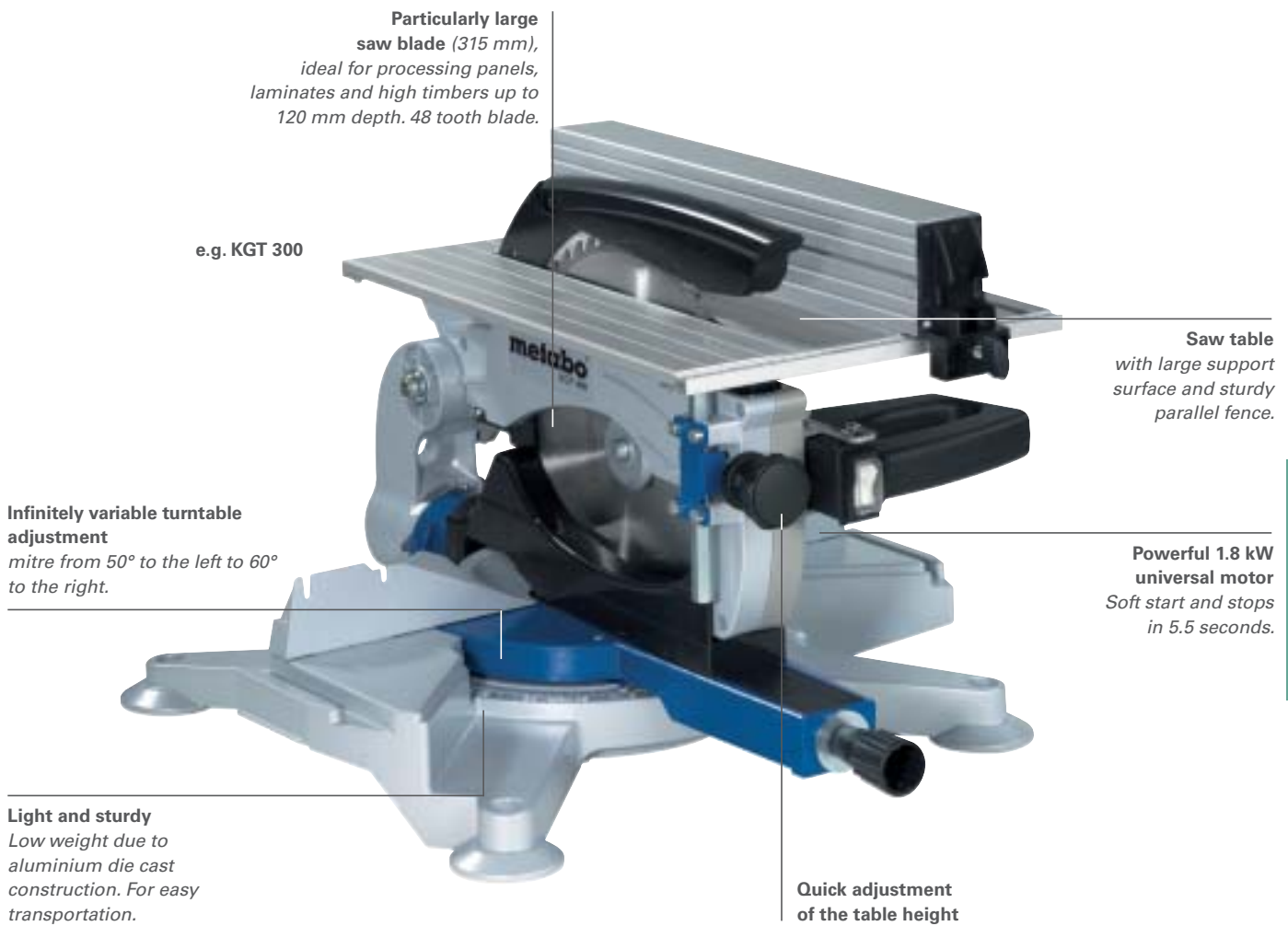

315 mm saw blade
Housing and holder allow the use of a 315 mm blade. This enables the clean cutting of timbers up to a height of 120 mm.



Saw head can be tilted
Bevel up to 48° left and 45° right.



Due to the special position of the motor, ideal cutting heights are possible, both for cross-cutting and table saw operation. The motor is no longer in the way.

EQUIPMENT FEATURES

- Changeover from crosscut to table operation in split seconds
- Powerful universal motor, stops in 5.5 seconds
- Low own weight for easy transport
- Double mitre cuts up to 45° due to inclinable saw head and integrated round table
- Saw head can be beveled on both sides
- Sturdy and precise aluminium cast construction
- Integrated holder grooves for attaching table length extension without tools
- Sturdy parallel guide/ripping fence

EQUIPMENT FEATURES

- Combined mounting saws with three functions: Crosscut saw, mitre saw and table saw
- Changeover from crosscut to table operation in split seconds
- Best cutting quality due to the torsion-free design
- Absolutely collision-free work with every angle setting
- Induction motor – quiet and maintenance-free, stops in 5.5 seconds
- Electronic motor brake
- Scale for infinitely variable angle adjustment and fine-adjustable snap-lock at 90° and 45°
- Sturdy and precise aluminium cast construction
- Stand fixed to the machine: foldable legs for problem-free work on the ground
- Sturdy parallel guide/ripping fence



KGT 300



KGT 501

Crosscut,
Mitre and Table Saw
KGT 300

Comparative device characteristics

| | |
|---|--------------------|
| Dimensions L x W x H | 575 x 760 x 730 mm |
| Working height without stand | 420 mm |
| Table size | 345 x 473 mm |
| Cutting width - cross cutting mode 90/45° | 170 mm/112 mm |
| Cutting depth - cross cutting mode 90/45° | 100 mm/66 mm |
| Cutting height – table mode 90° | 55 mm |
| No load speed | 3.400 /min |
| Cutting speed (maximum) | 56 m/s |
| Saw blade | Ø 315 x 30 mm |
| Adjustment options | |
| - Turntable left (maximum) | 50 ° |
| - Turntable right (maximum) | 60 ° |
| Rated input power | 1,8 kW |
| Output power | 1 kW |
| Motor protection | Circuit breaker |
| Weight | 21 kg |

Standard equipment

Carbide saw blade (48 teeth), chip hood, parallel guide/ripping fence, tool for saw blade change

Type
Order no.

KGT 300
0103300000 ■
0103300039 (GB) 110 V

Crosscut,
Mitre and Table Saw
KGT 501

Comparative device characteristics



| | |
|---|--------------------|
| Dimensions L x W x H | 620 x 663 x 878 mm |
| Working height without stand | 457 mm |
| Table size | 500 x 520 mm |
| Cutting width - cross cutting mode 90/45° | 210 mm/154 mm |
| Cutting depth - cross cutting mode 90/45° | 60 mm/45 mm |
| Cutting height – table mode 90° | 81 mm |
| No load speed | 3.620 /min |
| Cutting speed (maximum) | 42 m/s |
| Saw blade | Ø 250 x 30 mm |
| Adjustment options | |
| - Turntable left (maximum) | 45 ° |
| - Turntable right (maximum) | 45 ° |
| Rated input power | 2 kW |
| Output power | 1,5 kW |
| Motor protection | Circuit breaker |
| Weight (including stand) | 45 kg |

Standard equipment

Carbide saw blade (34 teeth), chip hood, parallel guide/ripping fence, foldable stand, tool for saw blade change

Type
Order no.

KGT 501
0102505018 ■
0102505042 (GB) 230 V
0102505034 (GB) 110 V

| Machine stand | | Order no. |
|---|---|------------|
|  | <p>Universal machine stand</p> <ul style="list-style-type: none"> For ideal working height and secure base Can also be used on uneven surfaces Collapsible, with height compensation <p>Suitable for: KS 210 C, KGS 255, KGS 301, KGS 303, KGS 305, KGS 331, KGT 300</p> | 0910057529 |
|  | <p>Machine stand KSU 400</p> <ul style="list-style-type: none"> Machine stand and table extension in one sturdy construction Universal end profile makes it suitable for all the conventional crosscut saws of well-known manufacturers Sturdy legs with height adjustment Extensive range of accessories <p>Max. total length 400 cm Max. weight load in central part 250 kg Weight: 25 kg</p> <p>For accessories for the machine stand KSU 400, see page 243</p> | 0910066110 |

NEW

| Work clamps | | Order no. |
|---|---|------------|
|  | <p>Work clamp</p> <ul style="list-style-type: none"> For the secure clamping of smaller workpieces, plastic or aluminium profiles <p>Suitable for: KGS 255, KGS 303, KGS 305, KGT 300, KGT 501, KS 210 C, KS 210 Lasercut KGT 501 from model year 2003 on</p> | 0910057553 |

ACCESSORIES FOR KGT 300

| Table length extensions | | Order no. |
|---|---|------------|
|  | <p>Table length extension right, steel</p> <ul style="list-style-type: none"> For the secure supporting of long workpieces With length guide and scale, up to 1,600 mm Dimension slide for repeating accuracy <p>Length: 1.140 mm Width: 200 mm</p> | 0910058886 |
|  | <p>Table length extension left, steel</p> <ul style="list-style-type: none"> For the secure supporting of long workpieces With length guide and scale, up to 1,600 mm Dimension slide for repeating accuracy <p>Length: 1.000 mm Width: 200 mm</p> | 0910058827 |

| | | Order no. |
|--|---|------------|
|  | <p>Table length extension right, steel</p> <ul style="list-style-type: none"> For the secure supporting of long workpieces With length guide and scale, extractable up to 3,000 mm Dimension slide for repeating accuracy <p>Length: 1.140 mm Width: 200 mm</p> | 0910058894 |
|  | <p>Table length extension left, steel</p> <ul style="list-style-type: none"> For the secure supporting of long workpieces With length guide and scale, extractable up to 3,000 mm Dimension slide for repeating accuracy <p>Length: 1.000 mm Width: 200 mm</p> | 0910058835 |
|  | <p>Table length extension right, aluminium</p> <ul style="list-style-type: none"> For the secure supporting of long workpieces With length guide and scale, extractable up to 3,000 mm Dimension slide for repeating accuracy Foldable and height-adjustable support leg <p>Length: 1.130 mm Width: 200 mm</p> | 0910057545 |
|  | <p>Table length extension left, aluminium</p> <ul style="list-style-type: none"> For the secure supporting of long workpieces With length guide and scale, extractable up to 3,000 mm Dimension slide for repeating accuracy Foldable and height-adjustable support leg <p>Length: 1.000 mm Width: 200 mm</p> | 0910057537 |



| Supplementary stops | | Order no. |
|---|--|------------|
|  | <p>Supplementary stop</p> <ul style="list-style-type: none"> For the safe and tear-free processing of small workpieces and strips Also particularly suitable for tall workpieces <p>Suitable for: KGS 255, KGS 303, KGT 300</p> | 0910059831 |

| Suction adapter | | Order no. |
|---|--|------------|
|  | <p>suction adapter</p> <p>Suitable for: KGS 255, KGS 301, KGS 303, KGS 305, KGT 300</p> | 0910059955 |

SAWS
SPECIAL-PURPOSE MACHINES
SYSTEMATIC ORGANISATION
GARDEN
WOOD-PROCESSING TECHNOLOGY
WATER-/PUMP TECHNOLOGY
WELDING TECHNOLOGY
COMPRESSED AIR SYSTEMS

ACCESSORIES FOR KGT 501



| Table length extensions | |
|---|------------|
| | Order no. |
|  <p>Table length extension</p> <ul style="list-style-type: none"> For the secure supporting of long workpieces With length guide and scale, extractable up to 2,800 mm With extension profile and 2 dimension slides for repeating accuracy Can be used left and right for cutting to length <p>Length: 1.000 mm Width: 200 mm</p> | 0910053213 |

| Sliding table | |
|---|------------|
| | Order no. |
|  <p>Sliding table</p> <ul style="list-style-type: none"> Enables exact cuts, even on larger workpieces Sliding table on ball bearings Cross-cut guide for cutting to length up to 1,000 mm, with dimension slide, magnifier and adjustable aluminium scale Easy to mount and dismount <p>Cutting width 90°/45°: 650 mm/890 mm Table size: 350 x 290 mm Overall length: 1.170 mm Base weight: 23 kg</p> | 0910053205 |
|  <p>Guide length extension for sliding tables</p> <ul style="list-style-type: none"> For use in the cross-cut guide of the sliding table Enables the cutting to length of workpieces of up to 2,000 mm Adjustable scale made of aluminium | 0910055100 |

| Mitre guides | |
|---|------------|
| | Order no. |
|  <p>Mitre guide</p> <ul style="list-style-type: none"> For precise cross cuts and angular cuts With workpiece bearing made of aluminium Infinitely variable, both sides adjustable, 90°-45° <p>Suitable for: KGT 500, KGT 501</p> | 0910009028 |

| Positioning laser | |
|--|------------|
| | Order no. |
|  <p>Positioning laser</p> <ul style="list-style-type: none"> For a perfect preview of the sawing cut The workpiece can be positioned quickly and securely for cutting No more test cuts <p>Battery-powered line laser Suitable for: KGS 301, KGS 331, KGT 500, KGT 501</p> | 0910040553 |

| Chip and dust extraction units | |
|---|------------|
| | Order no. |
|  <p>Chip and dust extraction unit</p> <ul style="list-style-type: none"> For a cleaner work environment and an unobstructed view of the workpiece you want to cut For connection to a chip and dust extraction unit <p>Extraction nozzle Ø: 100 mm Suitable for: KGT 500, KGT 501</p> | 0910009249 |

| Roller stands | |
|---|------------|
| | Order no. |
|  <p>Roller stand RS 420 Width: 400 mm Base weight: 100 kg Height: 640 - 1.015 mm</p> | 0910053353 |
|  <p>Roller stand RS 420 G Width: 520 mm Base weight: 100 kg Height: 640 - 1.015 mm</p> | 0910053345 |
|  <p>Roller stand RS 420 W Width: 420 mm Base weight: 100 kg Height: 640 - 1.015 mm</p> | 0910053361 |

| Circular saw blades | |
|---|--|
|  <ul style="list-style-type: none"> Top cutting results thanks to teeth ground on all sides and high accuracy of flatness and concentric running Tungsten carbide blades: long tool life thanks to use of unmixed carbide Can be reground repeatedly Made in Germany | |

| Material | Dimensions mm | Tooth pitch | Version | Order no. |
|--------------------|----------------|-------------|--|-----------|
| For KGT 501 | | | | |
| Tungsten carbide | 250 x 2,8 x 30 | 34 | Alternately bevel-ground tips, Combo secondary hole holder | 6.28045 |
| Tungsten carbide | 250 x 2,8 x 30 | 42 | Alternately bevel-ground tips, Combo secondary hole holder | 6.28046 |
| Tungsten carbide | 250 x 2,8 x 30 | 80 | Alternately bevel-ground tips, Combo secondary hole holder | 6.28087 |
| Tungsten carbide | 250 x 2,8 x 30 | 80 | Flat tooth/ trapezoidal tooth, 5° neg. | 6.28088 |
| For KGT 300 | | | | |
| Tungsten carbide | 315 x 2,8 x 30 | 20 | Flat tooth, Combo secondary hole holder | 6.28015 |
| Tungsten carbide | 315 x 2,8 x 30 | 48 | Alternately bevel-ground tips, 0° | 6.28057 |
| Tungsten carbide | 315 x 2,8 x 30 | 84 | Alternately bevelground tips | 6.28058 |
| Tungsten carbide | 315 x 2,8 x 30 | 96 | Flat tooth/ trapezoidal tooth, 5° neg. | 6.28092 |

NO TEARS – NO EFFORT.

The basic principle is “pulling instead of pushing”. Those who have had to cut long, difficult or particularly hard workpieces know that pulling is easier and cleaner than pushing. Considerably less teeth cut through

the wood, the cut can be controlled better and there are less tears. At the same time, the flush-mounted circular saw principle protects the saw blades, thus increasing their service life significantly.

e.g. UK 333

Precise workpiece support
Table-top made of aluminium profiles.

333 mm pulling length
All normal laminated floors and panels can be cut in two completely by up to 45°.

Sturdy and firm
side parts made of solid steel sheet.

Practical accessories
For example, table length extension or sliding carriage – easy to mount.



Always firm
Integrated, folding stand with level compensation for a firm base. The machine can also be operated when folded.

High quality universal fence
for angle settings from -90° to +90°.

Absolutely flexible
Powerful universal motor and speed regulation by Metabo VC electronics for constant speed under moderate loading.



Quick conversion
The UK 333 can be converted to a table saw. The universal fence becomes a parallel stop for cutting long workpieces.

Always mobile
The stand can be folded in easily. The UK 333 is therefore easy to transport and fits in every car.

Versatile cuts
The universal fence can be rotated by 180° for mitre and double-mitre cuts. The saw blade can be inclined from -1.5° to 46.5°; ideal for undercutting.

SAWS

SPECIAL-PURPOSE MACHINES

SYSTEMATIC ORGANISATION

GARDEN

WOOD-PROCESSING TECHNOLOGY

WATER-/PUMP TECHNOLOGY

WELDING TECHNOLOGY

COMPRESSED AIR SYSTEMS

COMMON FEATURES

- The first mobile professional saw with the functions and advantages of a crosscut and mitre saw, a flush-mounted circular saw and a table saw
- Three machines in one – mitre saw, flush-mounted logging saw and table saw
- Available as a complete set for performing a wide range of work to a high quality
- Quick assembly of the delivered accessories
- Mobile due to low weight
- Motor with overload protection and soft start technology
- Reversible from mitre saw to table saw function in seconds
- High quality, swivelling universal guide adjustable on all sides of the machine table for mitre and parallel cutting
- Infinitely swivel and height adjustable saw blade
- Integrated, foldable stand with level adjustment for safety
- Precise workpiece support made of aluminium profiles
- Side part made of solid steel sheet
- For single phase alternating current



UK 290
NEW



UK 290 Set
NEW

| | Flush-mounted circular saw UK 290 | Flush-mounted circular saw UK 290 Set |
|---|---|--|
| Special advantages | | |
| ■ Upgradable to a system circular saw | • | • |
| ■ Sliding table, table width and length extension for precise sawing of large work pieces | | |
| Comparative device characteristics | | |
| Dimensions L x W x H | 674 x 478 x 878 mm | 1.600 x 1.180 x 878 mm |
| Working height without stand | 420 mm | 420 mm |
| Table size | 478 x 674 mm | 478 x 674 mm |
| Cutting height 90/45° | 60 mm/42 mm | 60 mm/42 mm |
| No load speed | 4.500 /min | 4.500 /min |
| Rated load speed | 3.800 /min | 3.800 /min |
| Saw blade | Ø 220 x 30 mm | Ø 220 x 30 mm |
| Inclination range | -1,5 - 46,5 ° | -1,5 - 46,5 ° |
| Cutting speed (maximum) | 44 m/s | 44 m/s |
| Chain length | 290 mm | 290 mm |
| Rated input power | 1,8 kW | 1,8 kW |
| Output power | 1,2 kW | 1,2 kW |
| Weight (including stand) | 25 kg | 52 kg |
| Standard equipment | Carbide saw blade with alternately bevel-ground tooth (36 teeth), foldable stand, universal guide, splitting wedge, push stick, chip extraction connections | Carbide saw blade with alternately bevel-ground tooth (36 teeth), foldable stand, universal guide, fence profile 700 mm, splitting wedge, push stick, chip and dust extraction unit, table length extension, parallel guide/ripping fence, table length extension, sliding table |
| Type | UK 290 | UK 290 Set |
| Order no. | 0102900000 | 0192901000 |

COMMON FEATURES

- The first mobile professional saw with the functions and advantages of a crosscut and mitre saw, a flush-mounted circular saw and a table saw
- Available as a complete set for performing a wide range of work to a high quality
- Quick assembly of the delivered accessories
- Mobile due to low weight
- Powerful universal motor and speed regulation with Metabo VC electronics
- Motor with overload protection and soft start technology
- Reversible from mitre saw to table saw function in seconds
- High quality, swivelling universal guide adjustable on all sides of the machine table for mitre and parallel cutting
- Infinitely swivel and height adjustable saw blade
- Integrated, foldable stand with level adjustment for safety
- Flush-mounted light running slides made of aluminium die cast with 8 ball bearings for maximum precision
- Precise workpiece support made of aluminium profiles
- Side part made of solid steel sheet
- For single phase alternating current



UK 333



UK 333 Set

| | Flush-mounted circular saw UK 333 | Flush-mounted circular saw UK 333 Set |
|---|---|--|
| Special advantages | | |
| ■ Sliding table, table width and length extension for precise sawing of large work pieces | | • |
| Comparative device characteristics | | |
| Dimensions L x W x H | 760 x 585 x 900 mm | 1.600 x 1.287 x 900 mm |
| Working height without stand | 418 mm | 418 mm |
| Table size | 585 x 750 mm | 585 x 750 mm |
| Cutting height 90/45° | 70 mm/49 mm | 70 mm/49 mm |
| No load speed | 1.800 - 4.500 /min | 1.800 - 4.500 /min |
| Rated load speed | 4.500 /min | 4.500 /min |
| Saw blade | Ø 220 x 30 mm | Ø 220 x 30 mm |
| Inclination range | -1,5 - 46,5 ° | -1,5 - 46,5 ° |
| Cutting speed (maximum) | 52 m/s | 52 m/s |
| Chain length | 333 mm | 333 mm |
| Rated input power | 2,2 kW | 2,2 kW |
| Output power | 1,5 kW | 1,5 kW |
| Weight (including stand) | 35,9 kg | 63 kg |
| Standard equipment | Carbide saw blade with alternately bevel-ground tooth (36 teeth), foldable stand, universal guide, splitting wedge, cutting height indicator, push stick, chip extraction connections | Carbide saw blade with alternately bevel-ground tooth (36 teeth), foldable stand, universal guide, fence profile 700 mm, splitting wedge, cutting height indicator, push stick, chip and dust extraction unit, table length extension, parallel guide/ripping fence, table length extension, sliding table |
| Type | UK 333 | UK 333 Set |
| Order no. | 0103330000 | 0193330000 |

EQUIPMENT FEATURES

- The first mobile professional saw with the functions and advantages of a crosscut and mitre saw, a flush-mounted circular saw and a table saw
- Extremely stable, light and mobile due to the magnesium machine table
- Mobile due to low weight
- Motor with overload protection and soft start technology
- Reversible from mitre saw to table saw function in seconds
- Saw table rotatable by 180°, unique worldwide: reduced space requirement for various applications and enables sawing on smallest space

- High quality, swivelling universal guide adjustable on all sides of the machine table for mitre and parallel cutting
- Infinitely swivel and height adjustable saw blade
- Integrated, foldable stand with level adjustment for safety
- Flush-mounted light running slides made of aluminium die cast with 8 ball bearings for maximum precision
- For single phase alternating current



Secanta

ACCESSORIES FOR UK 290 AND UK 333

Work benches



Flexo 500 universal table

- For the stationary use of Metabo jig saws, routers and circular saws (when using appropriate accessories)
- With foldable stand and height adjustment
- Also usable as a table extension or work station in combination with the UK 290 or UK 333
- Sturdy steel construction and a large table top made from continuous strand casting

Order no.

0910064304



Wheel Sets



Wheel set

- Easy and convenient to transport

Order no.

0910064363¹⁾

Sliding table



Sliding table

- Large and wide work pieces can be easily guided through the saw blade
 - Clean and precise cutting results
 - Easy to mount and dismount
 - Safe working conditions
- Table size: 310 x 200 mm
Overall length: 1.225 mm
Base weight: 7,7 kg

Order no.

0910064347¹⁾

¹⁾ standard equipment with UK 290 set and UK 333 set

| Flush-mounted circular saw Secanta | |
|---|--|
| Comparative device characteristics | |
| Dimensions L x W x H | 730 x 750 x 910 mm |
| Working height without stand | 330 mm |
| Table size | 750 x 730 mm |
| Cutting height 90/45° | 70 mm/49 mm |
| Turntable diameter | 650 mm |
| No load speed | |
| Rated load speed | 4.500 /min |
| Saw blade | Ø 220 x 30 mm |
| Inclination range | -2 - 47 ° |
| Cutting speed (maximum) | 52 m/s |
| Chain length | 285 mm |
| Rated input power | 1,8 kW |
| Output power | 1,1 kW |
| Weight | 28 kg |
| Weight (including stand) | 32 kg |
| Standard equipment | Carbide saw blade with alternately bevel-ground tooth (36 teeth), foldable stand, universal guide, splitting wedge, cutting height indicator, push stick, chip extraction connections, chip and dust extraction unit |
| Type | Secanta |
| Order no. | 0102207009 |

| Table width extensions | | Order no. |
|---|--|--------------------------|
|  | <p>NEW Table width extension</p> <ul style="list-style-type: none"> Increases the supporting surface; ideal for large boards Enables cuts with parallel guide of up to 610 mm Height adjustable <p>Length: 674 mm Width: 501 mm</p> | 0910064401 ¹⁾ |

| Table length extensions | | Order no. |
|---|---|--------------------------|
|  | <p>NEW Table length extension</p> <ul style="list-style-type: none"> Practical cutting lengths for longer work pieces Safe working conditions <p>Length: 380 mm Width: 476 mm</p> | 0910064312 ¹⁾ |

| Parallel stops | | Order no. |
|--|--|--------------------------|
|  | <p>NEW Parallel guide/ripping fence</p> <ul style="list-style-type: none"> For long cuts or for cutting large boards Long attachment profile for guiding the work piece safely | 0910063707 ¹⁾ |

¹⁾ standard equipment with UK 290 set and UK 333 set

| Universal guides | | Order no. |
|---|---|------------|
|  | <p>Universal guide</p> <ul style="list-style-type: none"> Can be used as a spare or as a second mitre guide For mitre cuts and double mitre cuts Can be turned 180° (2 x 90°) <p>Stop slide length: 450 mm Suitable for: UK 333</p> | 0910063057 |

| Splinter protection | | Order no. |
|---|--|------------|
|  | <p>Splinter protection (set=10 units)</p> <ul style="list-style-type: none"> Is used in front of the saw blade and minimises tears on the recess side of the workpiece <p>Suitable for: UK 333</p> | 0910062107 |

| Chip and dust extraction units | | Order no. |
|--|--|--------------------------|
|  | <p>NEW Chip and dust extraction unit</p> <ul style="list-style-type: none"> Extraction at two points: at chip box and at the top on the guard Clear view of the work piece Cleaner working environment <p>Extraction nozzle Ø: 100 mm</p> | 0910064371 ¹⁾ |

¹⁾ standard equipment with UK 290 set and UK 333 set

| Work clamps | | Order no. |
|---|--|------------|
|  | <p>NEW Work clamp</p> <ul style="list-style-type: none"> For the secure clamping of smaller workpieces, round stock, plastic or aluminium profiles Suitable for using with universal guide <p>Max. clamping height 75 mm</p> | 0910064495 |

| | | |
|---|---|------------|
|  | <p>Work clamp</p> <ul style="list-style-type: none"> For the secure clamping of smaller workpieces, round stock, plastic or aluminium profiles Suitable for use on the universal guide and sliding table Also suitable for the table length extensions <p>Max. clamping height 55 mm Suitable for: UK 220, UK 333</p> | 0910053124 |
|  | <p>NEW Work clamp UK 290/UK 333</p> <ul style="list-style-type: none"> For clamping work pieces on to the sliding table | 0910064509 |

| Saw blade depot | | Order no. |
|--|---|------------|
|  | <p>NEW Saw blade depot</p> <ul style="list-style-type: none"> Saw blade depot with measuring tape, angle bevel and pencil To safely store a maximum of two circular saw blades up to Ø 254 mm (Saw blades not included) <p>Suitable for attaching the Flexo 500 universal table, the stands for the UK 290, UK 333 flush-mounted circular saws Crosscut, mitre and table saws.</p> | 0910064339 |

SAWS

SPECIAL-PURPOSE MACHINES

SYSTEMATIC ORGANISATION

GARDEN

WOOD-PROCESSING TECHNOLOGY

WATER-/PUMP TECHNOLOGY

WELDING TECHNOLOGY

COMPRESSED AIR SYSTEMS

ACCESSORIES FOR UK 333 AND SECANTA

| Sliding table | | Order no. |
|--|--|------------|
|  | <p>Sliding table</p> <ul style="list-style-type: none"> Enables exact cuts, even on larger workpieces Sliding table on ball bearings Cross-cut guide for cutting to length up to 1,000 mm, with dimension slide, magnifier and adjustable aluminium scale Easy to mount and dismount <p>Cutting width 90°/45°: 650 mm/890 mm Table size: 350 x 290 mm Overall length: 1.170 mm Base weight: 23 kg</p> | 0910053205 |

| Guide length extensions | | Order no. |
|---|--|------------|
|  | <p>Guide length extension for sliding tables</p> <ul style="list-style-type: none"> For use in the cross-cut guide of the sliding table Enables the cutting to length of workpieces of up to 2,000 mm Adjustable scale made of aluminium | 0910055100 |

| Table length extensions | | Order no. |
|--|---|------------|
|  | <p>Table length extension</p> <ul style="list-style-type: none"> For the secure supporting of long workpieces With length guide and scale, extractable up to 2,800 mm With extension profile and 2 dimension slides for repeating accuracy Can be used left and right for cutting to length <p>Foldable and height-adjustable support leg Length: 1.000 mm Width: 200 mm</p> | 0910053213 |

| Universal guides | | Order no. |
|---|--|------------|
|  | <p>Universal guide</p> <ul style="list-style-type: none"> Can be used as a spare or as a second mitre guide For mitre cuts and double mitre cuts Can be turned 180° (2 x 90°) <p>Stop slide length: 500 mm Suitable for: Secanta</p> | 0910053574 |

| Push block | | Order no. |
|---|---|------------|
|  | <p>Push block</p> <ul style="list-style-type: none"> For the lateral guiding of the workpiece | 0910057200 |

| Spray for maintenance and care | | Order no. |
|--|---|------------|
|  | <p>Spray for maintenance and care</p> <ul style="list-style-type: none"> Ideal for maintenance and care of wood processing machines Contains silicon, prevents saw dust from sticking, e.g. to threaded rods or sliding bearings Increases the sliding quality of the workpieces on the machine table High cleaning capacity | 0911018691 |

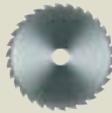
| Circular saw blades | |
|---|---|
|  | <ul style="list-style-type: none"> Top cutting results thanks to teeth ground on all sides and high accuracy of flatness and concentric running Tungsten carbide blades: long tool life thanks to use of unmixed carbide Can be reground repeatedly Made in Germany |

| Material | Dimensions mm | Tooth pitch | Version | Order no. |
|------------------------------------|----------------|-------------|-------------------------------|-----------|
| For UK 290, UK 333, Secanta | | | | |
| Tungsten carbide | 220 x 2,6 x 30 | 36 | Alternately bevel-ground tips | 6.28042 |
| Tungsten carbide | 220 x 2,6 x 30 | 48 | Roof hollow tooth | 6.28043 |
| Tungsten carbide | 220 x 2,6 x 30 | 80 | Flat tooth/ trapezoidal tooth | 6.28084 |

COMMON FEATURES

- Demountable for large range of use
- For mobile use
- Inclinable saw blade
- Lockable switch protects from unauthorised use
- Large surface, anodised tables made of aluminium extruded sections
- Dustproof according to TRGS 553 by FPH
- Extensive range of accessories



SAWS
SPECIAL-PURPOSE MACHINES
SYSTEMATIC ORGANISATION
GARDEN

| | Precision circular saw PK 200 | Precision circular saw PK 255 - 2.5 WN | Precision circular saw PK 255 - 3.4 DN |
|--|---|--|--|
| Special advantages | | | |
| ■ Powerful universal motor | | • | • |
| ■ Table length extension and stand included in the scope of delivery | | • | • |
| ■ For single phase alternating current | • | • | |
| ■ For three phase current | | | • |
| Comparative device characteristics | | | |
| Dimensions L x W x H | 540 x 430 x 330 mm | 1.380 x 780 x 1.000 mm | 1.380 x 780 x 1.000 mm |
| Table size | 430 x 540 mm | 660 x 760 mm | 660 x 760 mm |
| Cutting height 90/45° | 65 mm/45 mm | 80 mm/53 mm | 80 mm/53 mm |
| Rated load speed | 4.000 /min | 3.800 /min | 3.800 /min |
| Cutting speed | 44 m/s | 50 m/s | 50 m/s |
| Maximum cutting width | | | |
| - With parallel guide/ripping fence | 180 mm | 300 mm | 300 mm |
| Saw blade | Ø 210 x 30 mm | Ø 250 x 30 mm | Ø 250 x 30 mm |
| Saw blade swivel range | -1,5 - 46,5 ° | 0 - 45 ° | 0 - 45 ° |
| Rated input power | 1,7 kW | 2,5 kW | 3,4 kW |
| Output power | 1 kW | 1,9 kW | 2,5 kW |
| Weight | 21 kg | 71 kg | 71 kg |
| Standard equipment | Carbide circular saw blade (alternately bevel-ground tooth, 30 teeth), parallel guide/ripping fence, mitre guide, chip extraction connections, push stick | Carbide circular saw blade (alternately bevel-ground tooth, 34 teeth), stand, parallel guide/ripping fence, mitre guide, table length extension, chip extraction connections, push stick | Carbide circular saw blade (alternately bevel-ground tooth, 34 teeth), stand, parallel guide/ripping fence, mitre guide, table length extension, chip extraction connections, push stick |
| Type | PK 200 | PK 255 - 2.5 WN | PK 255 - 3.4 DN |
| Order no. | 0102001001 0102001010 ^{GB} 230 V | 0102582209 | 0102582802 |

WOOD-PROCESSING TECHNOLOGY
WATER-/PUMP TECHNOLOGY
WELDING TECHNOLOGY
COMPRESSED AIR SYSTEMS

COMMON FEATURES

- Demountable for large range of use
- For mobile use
- Powerful universal motor
- Table length extension and stand included in the scope of delivery
- Inclinable saw blade
- Lockable switch protects from unauthorised use
- Large surface, anodised tables made of aluminium extruded sections
- Dustproof according to TRGS 553 by FPH
- Extensive range of accessories



... with base support system, sliding table and table width extension











PK 255 - 2,5 WN

PK 255 - 3,4 DN

| | System circular saw PK 255 - 2.5 WN | System circular saw PK 255 - 3.4 DN |
|---|--|--|
| Special advantages | | |
| ▪ For single phase alternating current | • | |
| ▪ For three phase current | | • |
| Comparative device characteristics | | |
| Dimensions L x W x H | 1.560 x 1.400 x 1.000 mm | 1.560 x 1.400 x 1.000 mm |
| Table size | 660 x 760 mm | 660 x 760 mm |
| Cutting height 90/45° | 80 mm/53 mm | 80 mm/53 mm |
| Rated load speed | 3.800 /min | 3.800 /min |
| Cutting speed | 50 m/s | 50 m/s |
| Maximum cutting width | | |
| - With parallel guide/ripping fence | 300 mm | 300 mm |
| Saw blade | Ø 250 x 30 mm | Ø 250 x 30 mm |
| Saw blade swivel range | 0 - 45 ° | 0 - 45 ° |
| Rated input power | 2,5 kW | 3,4 kW |
| Output power | 1,9 kW | 2,5 kW |
| Weight | 74 kg | 74 kg |
| Standard equipment | Carbide circular saw blade (alternately bevel-ground tooth, 34 teeth), stand, basic support system (cutting width up to 700 mm), sliding table for basic support system, sliding table with support base, parallel guide/ripping fence, mitre guide, table length extension, chip extraction connections, push stick | Carbide circular saw blade (alternately bevel-ground tooth, 34 teeth), stand, basic support system (cutting width up to 700 mm), sliding table for basic support system, sliding table with support base, parallel guide/ripping fence, mitre guide, table length extension, chip extraction connections, push stick |
| Typ | PK 255 - 2,5 WN | PK 255 - 3,4 DN |
| Bestell-Nr. | 0192552508 | 0192553407 |



ACCESSORIES FOR PK 200 AND PK 255

| Machine stand | | Order no. |
|---|--|------------|
|  | <p>Machine stand</p> <ul style="list-style-type: none"> For ideal working height and secure base Easy to transport Collapsible <p>Suitable for: PK 200</p> | 0910017047 |
| Wheel Sets | | Order no. |
|  | <p>Wheel set</p> <ul style="list-style-type: none"> For easy transportation For assembly on the machine stand <p>Suitable for: PK 255</p> | 0910003313 |
| Base support system | | Order no. |
|  | <p>Base support system</p> <ul style="list-style-type: none"> Necessary for the mounting of sliding tables, table length extensions and table width extensions Fastening / locking at the front and rear side of the machine housing <p>Length: 1,180 mm Suitable for: PK 200</p> | 0910018450 |
| | <p>Base support system</p> <ul style="list-style-type: none"> Necessary for the mounting of sliding tables, table length extensions and table width extensions Fastening / locking at the front and rear side of the machine housing <p>Length: 1,180 mm Suitable for: PK 255</p> | 0910052411 |
| Accessories for the basic support system | | Order no. |
|  | <p>Extension</p> <ul style="list-style-type: none"> Lengthens the base support system by 720 mm Allows you to make broader cuts at the length guide of up to 1,400 mm <p>Delivery includes height-adjustable support leg</p> | 0910050028 |
|  | <p>Support base</p> <ul style="list-style-type: none"> Additional support leg for better support of the base support extension <p>Height adjustable</p> | 0910050036 |

| | | | |
|--|--|------------|----------------------------|
|  | <p>Sliding table</p> <ul style="list-style-type: none"> Enables exact cuts, even on larger workpieces Left/right mounting on the base support system Distance to the saw blade can be adjusted individually Eccentric clamp - easy to mount and remove <p>Cross-cut guide, length 700 mm, can be swivelled by 47° in either direction Suitable for: PK 200 Cutting width 90°/45°: 660 mm/910 mm Table size: 540 x 240 mm Overall length: 1.180 mm</p> | 0910018434 | SAWS |
|  | <p>Sliding table</p> <ul style="list-style-type: none"> Enables exact cuts, even on larger workpieces Left/right mounting on the base support system Distance to the saw blade can be adjusted individually Eccentric clamp - easy to mount and dismount <p>Cross-cut guide, length 700 mm, can be swivelled by 47° on both sides Suitable for: PK 255 Cutting width 90°/45°: 900 mm/1.140 mm Table size: 540 x 240 mm Overall length: 1.550 mm</p> | 0910052420 | |
|  | <p>Table width extension</p> <ul style="list-style-type: none"> The table width extension increases the supporting surface; ideal for cutting boards Enables cuts on length guide up to 700 mm width When using a base support extension, cuts on the length guide of up to 1,400 mm wide are possible Left/right mounting on the base support system <p>Suitable for: PK 200 Length: 585 mm Width: 200 mm</p> | 0910018442 | SYSTEMATIC ORGANISATION |
|  | <p>Table width extension Plus</p> <ul style="list-style-type: none"> The table width extension increases the supporting surface; ideal for cutting boards Enables cuts on length guide up to 700 mm width When using a base support extension, cuts on the length guide of up to 1,400 mm wide are possible Left/right mounting on the base support system <p>Suitable for: PK 255 Length: 835 mm Width: 200 mm</p> | 0910064517 | GARDEN |
| | | | WOOD-PROCESSING TECHNOLOGY |
| | | | WATER-/PUMP TECHNOLOGY |
| | | | WELDING TECHNOLOGY |
| | | | COMPRESSED AIR SYSTEMS |

| | | |
|--|--|--------------------------------|
|  | Table length extension <ul style="list-style-type: none"> For the secure supporting of long workpieces With height adjustable support leg and auxiliary fence rail Eccentric clamp - easy to mount and dismount Front/rear mounting on the base support system <p>HC 333: Mounting possible on both sides of the dressing plates Length: 1.000 mm Width: 200 mm</p> | Order no. 0910018469 |
|--|--|--------------------------------|

Other accessories

| | | |
|--|--|--------------------------------|
|  | Mitre guide <ul style="list-style-type: none"> For precise cross cuts and angular cuts Infinitely variable, both sides adjustable, 90°-45° | Order no. 0910059963 |
| |  Mitre guide <ul style="list-style-type: none"> For precise cross cuts and angular cuts With workpiece bearing made of aluminium Infinitely variable, both sides adjustable, 90°-45° | Order no. 0910008048 |
|  | Roller stand RS 420 <ul style="list-style-type: none"> For supporting long workpieces when sawing, moulding/routing, planing and drilling Sturdy, height-adjustable and foldable <p>With smooth-rolling special steel rollers with a high load capacity Width: 400 mm Base weight: 100 kg Height: 640 - 1.015 mm</p> | Order no. 0910053353 |
| |  Roller stand RS 420 G <ul style="list-style-type: none"> For supporting long workpieces when sawing, moulding/routing, planing and drilling Sturdy, height-adjustable and foldable <p>With smooth-rolling chromium-plated ball bearings Also permits lateral movements Ideal for panel material Width: 520 mm Base weight: 100 kg Height: 640 - 1.015 mm</p> | Order no. 0910053345 |
|  | Roller stand RS 420 W <ul style="list-style-type: none"> For supporting long workpieces when sawing, moulding/routing, planing and drilling Sturdy, height-adjustable and foldable <p>With smooth-rolling chromium-plated ball bearings Adjustable ball bearing gib Also permits lateral movements Ideal for panel material, round or square workpieces Width: 420 mm Base weight: 100 kg Height: 640 - 1.015 mm</p> | Order no. 0910053361 |
| |  Push block <ul style="list-style-type: none"> For the lateral guiding of the workpiece | Order no. 0910057200 |

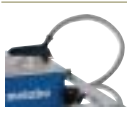
| | | |
|---|---|--------------------------------|
| Chip and dust extraction units | | Order no. |
|  | Chip and dust extraction unit <ul style="list-style-type: none"> For a cleaner work environment and an unobstructed view of the workpiece you want to cut For connecting to a chip and dust extraction system With this accessory, the machine is dust-proof <p>Extraction nozzle Ø: 100 mm Suitable for: PK 200</p> | Order no. 0910017608 |
| |  Chip and dust extraction unit <ul style="list-style-type: none"> For a cleaner work environment and an unobstructed view of the workpiece you want to cut For connecting to a chip and dust extraction system With this accessory, the machine is dust-proof <p>Extraction nozzle Ø: 100 mm Suitable for: PK 250 until 1993, PK 255</p> | Order no. 0910014374 |

| | |
|---|---|
| Circular saw blades | |
|  | <ul style="list-style-type: none"> Top cutting results thanks to teeth ground on all sides and high accuracy of flatness and concentric running Tungsten carbide blades: long tool life thanks to use of unmixed carbide Can be reground repeatedly Made in Germany |

| Material | Dimensions mm | Tooth pitch | Version | Order no. |
|-------------------|----------------|-------------|--|-----------|
| For PK 200 | | | | |
| Tungsten carbide | 210 x 2,4 x 30 | 30 | Alternately bevel-ground tips | 6.28036 |
| Tungsten carbide | 210 x 2,4 x 30 | 42 | Alternately bevel-ground tips | 6.28039 |
| Tungsten carbide | 210 x 2,4 x 30 | 64 | Alternately bevel-ground tips | 6.28081 |
| Tungsten carbide | 210 x 2,4 x 30 | 40 | Alternately bevel-ground tips, 3° | 6.28037 |
| For PK 255 | | | | |
| Tungsten carbide | 250 x 2,8 x 30 | 24 | Alternately bevel-ground tips | 6.28012 |
| Tungsten carbide | 250 x 2,8 x 30 | 34 | Alternately bevel-ground tips, Combo secondary hole holder | 6.28045 |
| Tungsten carbide | 250 x 2,8 x 30 | 42 | Alternately bevel-ground tips, Combo secondary hole holder | 6.28046 |
| Tungsten carbide | 250 x 2,8 x 30 | 60 | Alternately bevel-ground tips, Combo secondary hole holder | 6.28049 |
| Tungsten carbide | 250 x 3,2 x 30 | 60 | Alternately bevel-ground tips, Combo secondary hole holder | 6.28050 |
| Tungsten carbide | 250 x 2,8 x 30 | 80 | Alternately bevel-ground tips, Combo secondary hole holder | 6.28087 |
| Tungsten carbide | 250 x 2,8 x 30 | 80 | Flat tooth/ trapezoidal tooth, 5° negative | 6.28088 |

EQUIPMENT FEATURES

- Demountable for large range of use
- Powerful universal motor
- Parallel guide/ripping fence with magnifier and Nonius fine adjustment, double eccentric clamp
- With table extension in length and width for larger workpieces
- Inclinable saw blade
- Large and anodised aluminium table-top
- Machine housing made of powder-coated, torsion-resistant sheet steel
- Dustproof according to TRGS 553 by FPH
- Extensive range of accessories
- For three phase current



PK 300 - 4,2 DNB

**Precision circular saw
PK 300 - 4.2 DNB**

Comparative device characteristics

| | |
|-------------------------------------|--------------------------|
| Dimensions L x W x H | 1.480 x 1.430 x 1.050 mm |
| Table size | 710 x 900 mm |
| Cutting height 90/45° | 104 mm/70 mm |
| Rated load speed | 3.800 /min |
| Cutting speed | 50 m/s |
| Maximum cutting width | |
| - With parallel guide/ripping fence | 340 mm |
| Saw blade | Ø 300 x 30 mm |
| Saw blade swivel range | 0 - 45 ° |
| Rated input power | 4,2 kW |
| Output power | 3 kW |
| Weight | 90 kg |

Standard equipment

Carbide saw blade with alternately bevel-ground tooth (28 teeth), stand, parallel guide/ripping fence with magnifier, table length extension, table length extension, chip and dust extraction unit, chip extraction connections, push stick

Type
Order no.

PK 300 - 4.2 DNB
0103004217
0103003138 ^{GB} 230 V

Accessories

Order no.



Cabinet base

- For ideal working height and secure base
- Robust, powder-coated sheet steel construction

Working height: 920 mm

0910050435



Wheel set

- For the easy transportation of the machine mounted on the cabinet base

0910007262



Sliding table short

- Enables exact cuts, even on larger workpieces
- Easy fastening of the sliding table with snap locks
- Guide profile made of thick-walled aluminium and galvanised round steels
- Guided over four rollers with ball bearings

Guide with mm division, extractable up to 2,600 mm (telescope profile) with adjustable fence pointer
Cutting width 90°/45°: 610 mm/1.010 mm
Table size: 280 x 525 mm
Overall length: 1.500 mm
Base weight: 25 kg

0910003291



Sliding table long

- Enables exact cuts, even on larger workpieces
- Easy fastening of the sliding table with snap locks
- Guide profile made of thick-walled aluminium and galvanised round steels with height-adjustable support leg
- Guided over four rollers with ball bearings

Guide with mm division, extractable up to 2,600 mm (telescope profile) with adjustable fence pointer
Cutting width 90°/45°: 1.260 mm/1.660 mm
Table size: 280 x 525 mm
Overall length: 2.300 mm
Base weight: 35 kg

0910003321

SAWS

SPECIAL-PURPOSE
MACHINES

SYSTEMATIC
ORGANISATION

GARDEN

WOOD-PROCESSING
TECHNOLOGY

WATER-/PUMP
TECHNOLOGY



WELDING
TECHNOLOGY

COMPRESSED
AIR SYSTEMS

| | Order no. |
|---|------------|
|  <p>Table length extension</p> <ul style="list-style-type: none"> ■ The table extension increases the supporting surface (same width as the work bench), making it ideal for cutting long pieces of wood ■ Collapsible without having to use tools <p>Length: 710 mm Width: 570 mm</p> | 0910003330 |
|  <p>Table width extension</p> <ul style="list-style-type: none"> ■ The table width extension increases the supporting surface; ideal for cutting boards ■ Enables cuts on length guide up to 1,010 mm width ■ Collapsible without having to use tools <p>Length: 900 mm Width: 710 mm</p> | 0910003305 |
|  <p>Mitre guide</p> <ul style="list-style-type: none"> ■ For precise cross cuts and angular cuts ■ With workpiece bearing made of aluminium ■ Infinitely variable, both sides adjustable, 90°-45° <p>PK 300: can be used on the right and left of the saw blade</p> | 0910008048 |

Roller stands

- For supporting long workpieces when sawing, moulding/routing, planing and drilling
- Sturdy, height-adjustable and foldable

| | Order no. |
|---|------------|
|  <p>Roller stand RS 420 With smooth-rolling special steel rollers with a high load capacity Width: 400 mm Base weight: 100 kg Height: 640 - 1.015 mm</p> | 0910053353 |
|  <p>Roller stand RS 420 G With smooth-rolling chromium-plated ball bearings Also permits lateral movements Ideal for panel material Width: 520 mm Base weight: 100 kg Height: 640 - 1.015 mm</p> | 0910053345 |
|  <p>Roller stand RS 420 W With smooth-rolling chromium-plated ball bearings Adjustable ball bearing gib Also permits lateral movements Ideal for panel material, round or square workpieces Width: 420 mm Base weight: 100 kg Height: 640 - 1.015 mm</p> | 0910053361 |

Push block

| | Order no. |
|---|------------|
|  <p>Push block</p> <ul style="list-style-type: none"> ■ For the lateral guiding of the workpiece | 0910057200 |

Spray for maintenance and care

| | Order no. |
|---|------------|
|  <p>Spray for maintenance and care</p> <ul style="list-style-type: none"> ■ Ideal for maintenance and care of wood processing machines ■ Contains silicon, prevents saw dust from sticking, e.g. to threaded rods or sliding bearings ■ Increases the sliding quality of the workpieces on the machine table ■ High cleaning capacity | 0911018691 |

Circular saw blades

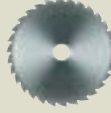
| |
|---|
|  <ul style="list-style-type: none"> ■ Top cutting results thanks to teeth ground on all sides and high accuracy of flatness and concentric running ■ Tungsten carbide blades: long tool life thanks to use of unmixed carbide ■ Can be reground repeatedly ■ Made in Germany |
|---|

| Material | Dimensions mm | Tooth pitch | Version | Order no. |
|------------------|----------------|-------------|--|-----------|
| Tungsten carbide | 300 x 2,8 x 30 | 28 | Alternately bevel-ground tips, Combo-secondary hole holder | 6.28014 |
| Tungsten carbide | 300 x 2,8 x 30 | 48 | Alternately bevel-ground tips, Combo-secondary hole holder | 6.28051 |
| Tungsten carbide | 300 x 3,2 x 30 | 60 | Roof hollow tooth, Combo-secondary hole holder | 6.28052 |
| Tungsten carbide | 300 x 2,8 x 30 | 72 | Alternately bevel-ground tips, Combo-secondary hole holder | 6.28053 |
| Tungsten carbide | 300 x 2,8 x 30 | 96 | Alternately bevel-ground tips, Combo-secondary hole holder | 6.28089 |
| Tungsten carbide | 300 x 2,8 x 30 | 96 | Flat tooth/ trapezoidal tooth, Combo-secondary hole holder | 6.28090 |

Free Manuals Download Website

<http://myh66.com>

<http://usermanuals.us>

<http://www.somanuals.com>

<http://www.4manuals.cc>

<http://www.manual-lib.com>

<http://www.404manual.com>

<http://www.luxmanual.com>

<http://aubethermostatmanual.com>

Golf course search by state

<http://golfingnear.com>

Email search by domain

<http://emailbydomain.com>

Auto manuals search

<http://auto.somanuals.com>

TV manuals search

<http://tv.somanuals.com>