

ALL VEHICLES

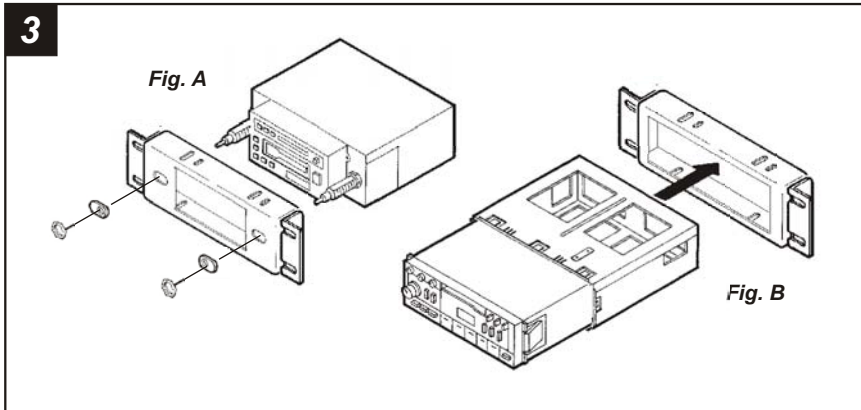

2-SHAFT HEAD UNITS: Attach the **Shaft Masks** to the **Radio Housing**. Slide the aftermarket head unit into the kit and secure with shaft nuts. (see Fig. A)

DIN HEAD UNITS: Using the scored lines on the back of the **Radio Housing** as a guide, cut and remove the shaft supports. Slide the DIN cage into the kit and secure by bending the metal locking tabs down. Slide the aftermarket head unit into the cage until secure. (see Fig. B)

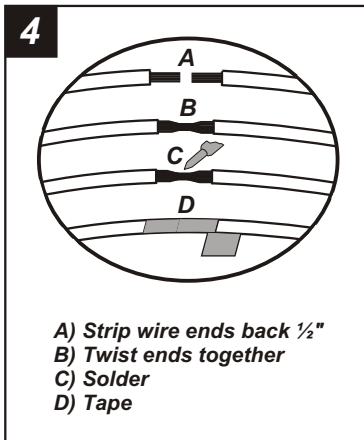

Locate the factory wiring harness in the dash. Metra recommends using the proper mating adaptor and making connections as shown. (Isolate and individually tape off the ends of any unused wires to prevent electrical short circuit).

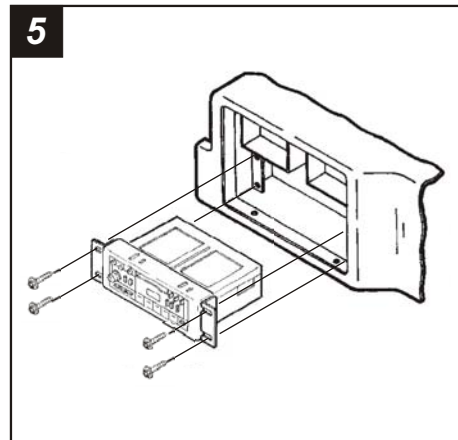

Re-connect the battery terminal and test the unit for proper operation. Mount the radio/kit assembly to the sub-dash with those screws previously removed in step #1.

KIT COMPONENTS

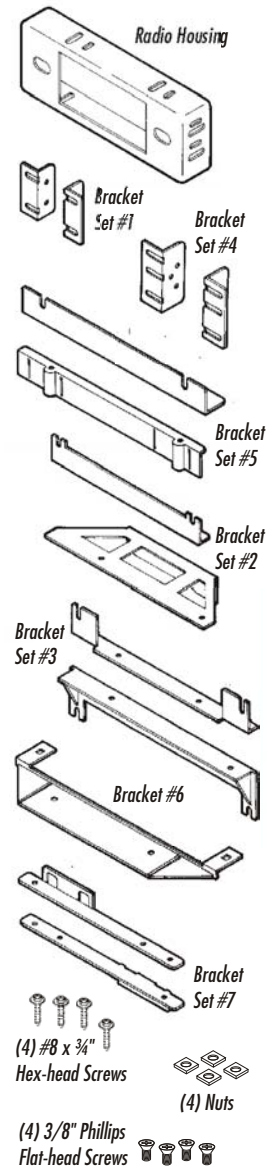

TOOLS REQUIRED



99-5500 INSTALLATION INSTRUCTIONS

APPLICATIONS

FORD/MERCURY 1979-91
(SEE INSIDE FOR SPECIFIC APPLICATIONS)

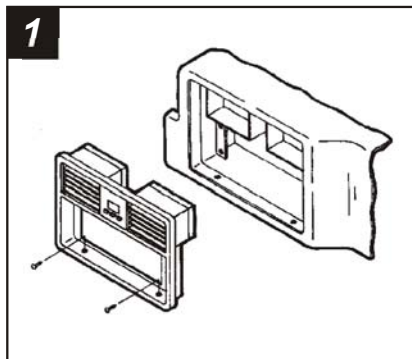

TABLE OF CONTENTS

CAR	PAGE	CAR	PAGE
FORD		FORD (cont.)	
Aerostar 1985-91.....	1	Taurus 1986-89.....	5
Bronco 1980-86.....	2	Tempo 1985-88.....	6
Bronco II 1983-88.....	2	Thunderbird 1985-88.....	6
Crown Victoria 1984-90.....	3	MERCURY	
Econoline 1975-91.....	3	Capri 1985-86.....	5
Escort 1985-90.....	4	Cougar 1985-88.....	6
EXP 1985-90.....	3	Grand Marquis 1984-90.....	3
LTD 1983-86.....	4	Lynx 1985-90.....	4
Mustang 1985-86.....	5	Marquis 1983-86.....	4
Pickup 1980-86.....	2	Sable 1986-89.....	5
Ranger 1983-88.....	2	Topaz 1985-88.....	6

 **If a 2-shaft head unit is being installed, be sure the studs on the Brackets fit into the SMALL ROUND HOLES in the Housing during the kit assembly in step #2.**
If a DIN head unit is being installed, be sure the studs on the Brackets fit into the SLOTTED HOLES in the Housing during the kit assembly in step #2.

FORD Aerostar 1985-91



Disconnect the negative battery terminal to prevent an accidental short circuit. Remove (2) screws from the bottom of the radio trim bezel. Pry down on the (2) tabs located at the top of the radio trim bezel and remove the bezel. Remove (4) screws securing the factory head unit and disconnect the wiring.

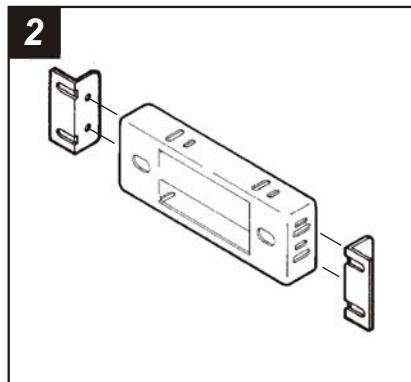

Mount **Bracket Set #1** to the **Radio Housing** with (4) 3/8" **Phillips Flat-head Screws** and (4) **Nuts** supplied. Skip to the *Installation Instructions for ALL VEHICLES on Page #7.*

FORD Tempo / MERCURY Topaz 1985-88

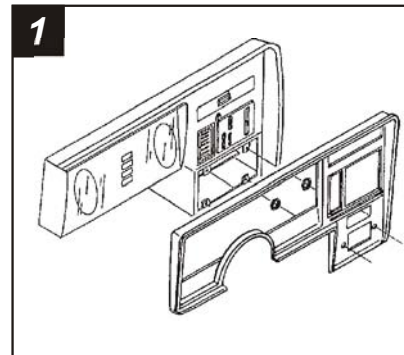

Disconnect the negative battery terminal to prevent an accidental short circuit. Remove the ashtray by disengaging the release tab at the rear of the ashtray bracket. Remove (2) screws from the lower edge of the dash trim bezel. Unsnap the top edge of the bezel and remove. Remove (4) screws securing the factory head unit and disconnect the wiring.

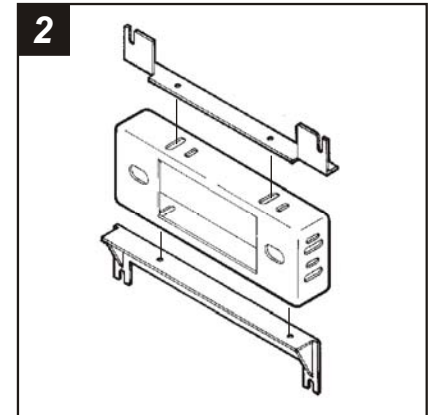

Mount **Bracket Set #3** to the **Radio Housing** with (4) 3/8" **Phillips Flat-head Screws** and (4) **Nuts** supplied. Skip to the *Installation Instructions for ALL VEHICLES on Page #7.*

FORD Thunderbird / MERCURY Cougar 1985-88

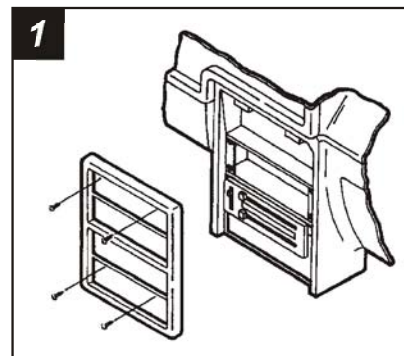

Disconnect the negative battery terminal to prevent an accidental short circuit. Open the ashtray and remove (2) screws exposed in the ashtray cavity. Remove (2) screws from the top of the dash trim bezel. Remove the bezel. Remove (4) screws securing the factory head unit and disconnect the wiring.

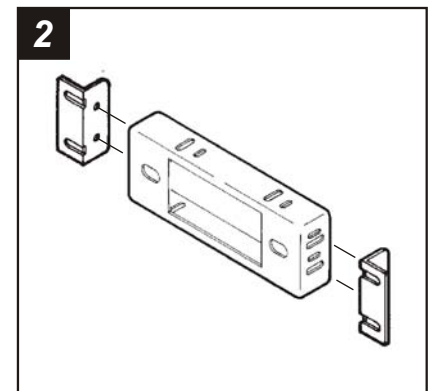

Mount **Bracket Set #1** to the **Radio Housing** with (4) 3/8" **Phillips Flat-head Screws** and (4) **Nuts** supplied. Skip to the *Installation Instructions for ALL VEHICLES on Page #7.*

FORD Mustang / MERCURY Capri 1985-86

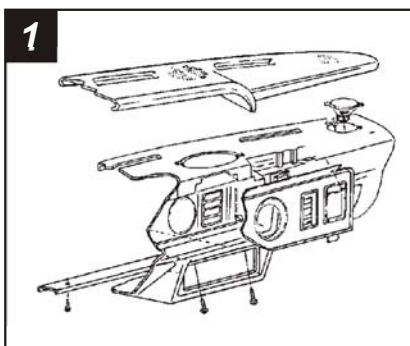

1
Disconnect the negative battery terminal to prevent an accidental short circuit. Open the console storage box and remove (4) screws exposed in the bottom of the box. Remove (2) screws securing the emergency brake trim and remove the trim. Unclip the gear shifter trim and remove. Open the ashtray and remove (2) screws exposed. Remove (4) screws under the ashtray opening. Remove the console. Remove (3) screws securing the factory head unit and disconnect the wiring.

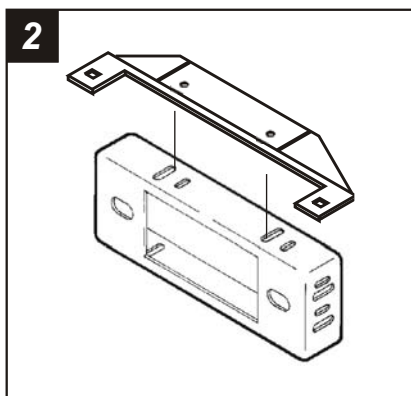

2
Mount **Bracket #6** to the **Radio Housing** with (2) **3/8" Phillips Flat-head Screws** and (2) **Nuts** supplied. Skip to the *Installation Instructions for ALL VEHICLES on Page #7.*

FORD Bronco / Pickup 1980-86

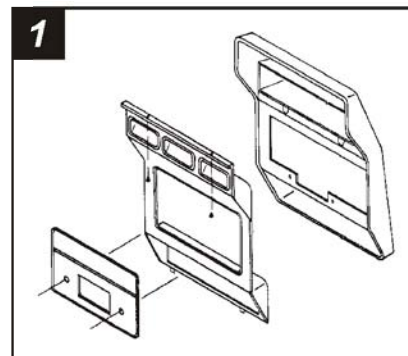

1
Disconnect the negative battery terminal to prevent an accidental short circuit. Remove (2) screws from the top edge of the dash trim bezel. Pull out on the top of the bezel, unhook the base and remove the bezel. If a factory head unit is NOT present, scribe the (4) mounting holes and radio opening onto the bezel. Drill the holes, cut the opening and place (4) U-clips over the mounting positions.

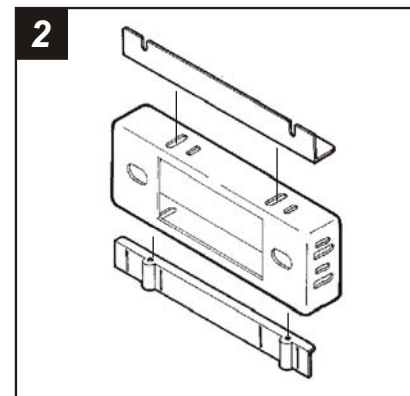

2
Mount **Bracket Set #5** to the **Radio Housing** with (4) **3/8" Phillips Flat-head Screws** and (4) **Nuts** supplied. Skip to the *Installation Instructions for ALL VEHICLES on Page #7.*

FORD Taurus / MERCURY Sable 1986-89

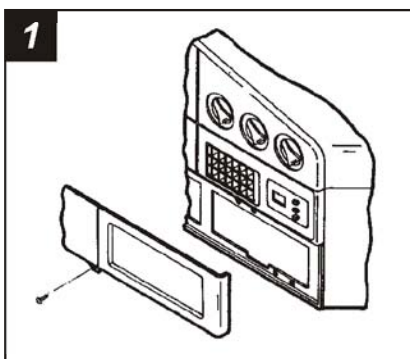

1
Disconnect the negative battery terminal to prevent an accidental short circuit. Remove (2) screws from the bottom of the radio trim bezel. Pry out on the edges of the bezel and remove. Remove (4) screws securing the factory head unit and disconnect the wiring.

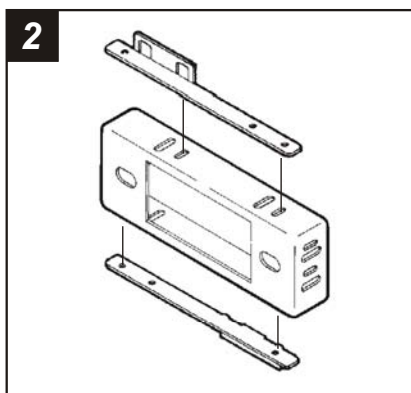

2
Mount **Bracket Set #7** to the **Radio Housing** with (4) **3/8" Phillips Flat-head Screws** and (4) **Nuts** supplied. Skip to the *Installation Instructions for ALL VEHICLES on Page #7.*

FORD Bronco II / Ranger 1983-88

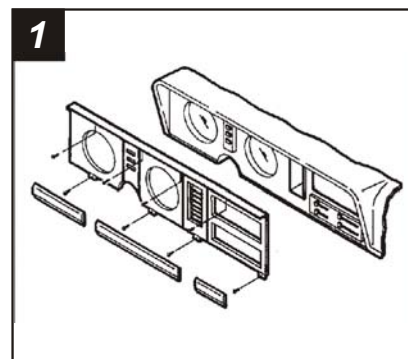

1
Disconnect the negative battery terminal to prevent an accidental short circuit. Remove (2) screws from the top edge of the dash trim bezel. Remove the light switch knob, cigarette lighter and ashtray. Unsnap the black trim molding under the dash trim bezel and remove (2) screws exposed. Remove the bezel. Remove (4) screws securing the factory head unit and disconnect the wiring.

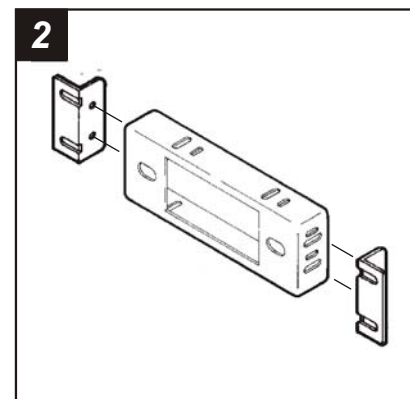

2
Mount **Bracket Set #1** to the **Radio Housing** with (4) **3/8" Phillips Flat-head Screws** and (4) **Nuts** supplied. Skip to the *Installation Instructions for ALL VEHICLES on Page #7.*

FORD Crown Victoria 1984-90 MERCURY Grand Marquis 1984-90

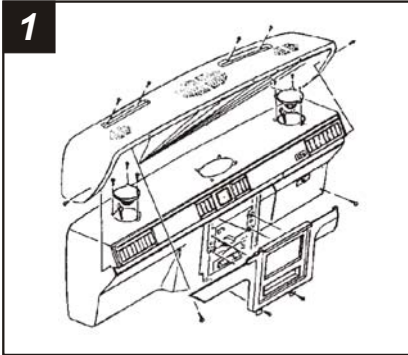

1
Disconnect the negative battery terminal to prevent an accidental short circuit. Open the ashtray and remove (2) screws exposed. Unclip the dash trim bezel and remove the radio dummy plate. Place (4) U-nuts over the mounting positions in the sub-dash.

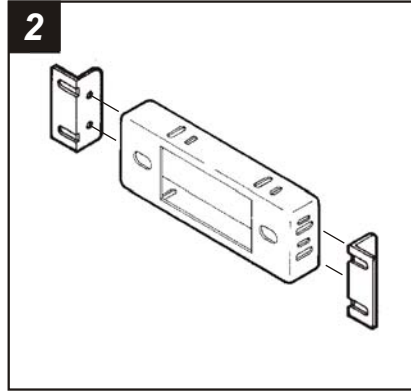

2
Mount **Bracket Set #1** to the **Radio Housing** with (4) **3/8" Phillips Flat-head Screws** and (4) **Nuts** supplied. Skip to the *Installation Instructions for ALL VEHICLES on Page #7.*

FORD Escort / MERCURY Lynx 1985-90

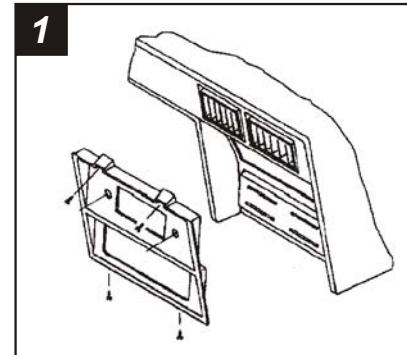

1
Disconnect the negative battery terminal to prevent an accidental short circuit. Remove (4) screws from the top edge of the radio trim bezel. Remove (2) screws from the bottom edge of the radio trim bezel. Remove the climate control knobs and unclip the bezel. Remove (4) screws securing the factory head unit and disconnect the wiring.

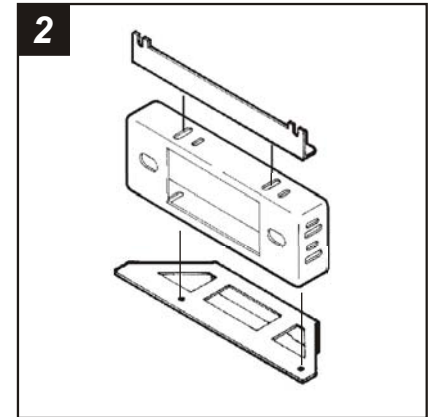

2
Mount **Bracket Set #2** to the **Radio Housing** with (4) **3/8" Phillips Flat-head Screws** and (4) **Nuts** supplied. Skip to the *Installation Instructions for ALL VEHICLES on Page #7.*

FORD Econoline 1975-91

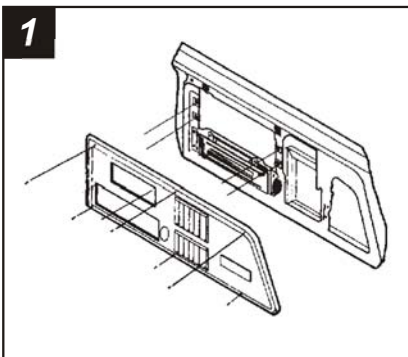

1
Disconnect the negative battery terminal to prevent an accidental short circuit. Remove (3) screws from the lower edge of the dash trim bezel. Remove (2) screws above the radio opening. Unsnap the right corner of the dash trim bezel, disconnect the cigarette lighter wiring and remove the bezel. Remove the screws securing the factory head unit and disconnect the wiring.

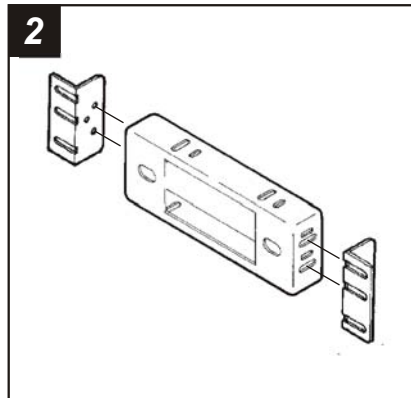

2
Mount **Bracket Set #4** to the **Radio Housing** with (4) **3/8" Phillips Flat-head Screws** and (4) **Nuts** supplied. Skip to the *Installation Instructions for ALL VEHICLES on Page #7.*

FORD LTD / MERCURY Marquis 1983-86

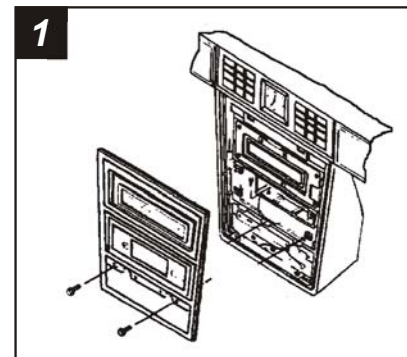

1
Disconnect the negative battery terminal to prevent an accidental short circuit. Remove the ashtray and climate control knobs. Remove (2) screws from the bottom of the dash trim bezel. Lift up on the bottom of the bezel and remove. Remove the screws securing the factory head unit and disconnect the wiring.

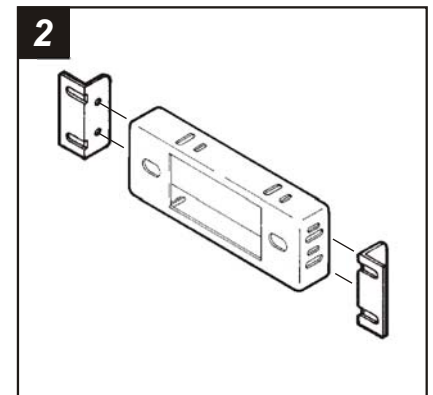

2
Mount **Bracket Set #1** to the **Radio Housing** with (4) **3/8" Phillips Flat-head Screws** and (4) **Nuts** supplied. Skip to the *Installation Instructions for ALL VEHICLES on Page #7.*

Free Manuals Download Website

<http://myh66.com>

<http://usermanuals.us>

<http://www.somanuals.com>

<http://www.4manuals.cc>

<http://www.manual-lib.com>

<http://www.404manual.com>

<http://www.luxmanual.com>

<http://aubethermostatmanual.com>

Golf course search by state

<http://golfingnear.com>

Email search by domain

<http://emailbydomain.com>

Auto manuals search

<http://auto.somanuals.com>

TV manuals search

<http://tv.somanuals.com>