



## INSTALLATION INSTRUCTIONS FOR PART 99-82275

### APPLICATIONS TOYOTA 4 RUNNER 2010

## 99-82275

### KIT FEATURES

- DIN Head unit provisions with pocket
- ISO DIN Head unit provision with pocket
- DDIN Head unit provision
- ISO Stacked Head unit provision
- Painted matte silver to match factory dash



### KIT COMPONENTS

- A) Radio Housing • B) ISO Brackets • C) ISO Trim Plate • D) DDIN Brackets
- E) DDIN Trim Plate • F) Pocket • G) [4] PC-7503 Panel Clips • H) [2] Phillips Screws

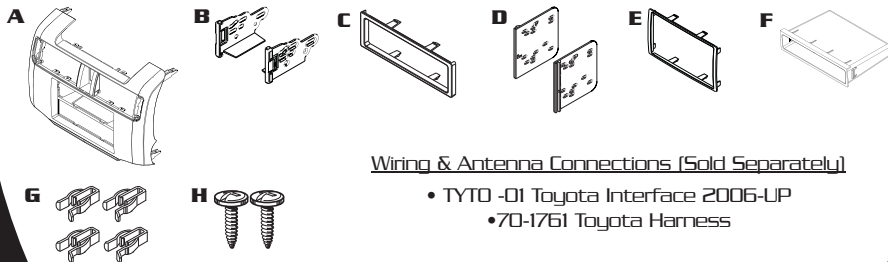

#### Wiring & Antenna Connections (Sold Separately)

- TYTO -01 Toyota Interface 2006-UP
- 70-1761 Toyota Harness

### TOOLS REQUIRED

- Phillips Screwdriver • Panel Removal Tool • Small Flat Blade Screwdriver
- Small Socket Set



METRA. THE WORLD'S BEST KITS.™



1-800-221-0932



metraonline.com

© COPYRIGHT 2004-2010 METRA ELECTRONICS CORPORATION

Download from [www.Somanuals.com](http://www.Somanuals.com). All Manuals Search And Download.



## TABLE OF CONTENTS

### DASH DISASSEMBLY

- TOYOTA 4 RUNNER 2010 . . . . . 1-2

### KIT PREPARATION

- TOYOTA 4 RUNNER 2010 . . . . . 3

### KIT ASSEMBLY

#### TOYOTA 4 RUNNER 2010

- DIN HEAD UNIT PROVISION . . . . . 4
- ISO DIN HEAD UNIT PROVISION . . . . . 5
- DOUBLE DIN HEAD UNIT PROVISION . . . . . 6

**CAUTION:** Metra recommends disconnecting the negative battery terminal before beginning any installation. All accessories, switches, and especially air bag indicator lights must be plugged in before reconnecting the battery or cycling the ignition.

**NOTE:** Refer Also to the instructions included with the aftermarket radio.



### KNOWLEDGE IS POWER

Enhance your installation and fabrication skills by enrolling in the most recognized and respected mobile electronics school in our industry. Log onto [www.installerinstitute.com](http://www.installerinstitute.com) or call 800-354-6782 for more information and take steps toward a better tomorrow.



Metra recommends MECP certified technicians

## 99-82275 DASH DISASSEMBLY

### TOYOTA 4 RUNNER 2010

- 1** Unclip and remove the (2) climate control knob trim panels. (Fig. A)
- 2** Unclip and remove the climate control. (Fig. B)
- 3** Remove (4) 10 MM bolts securing the radio. (Fig. C)

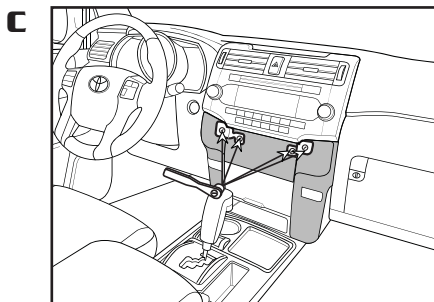
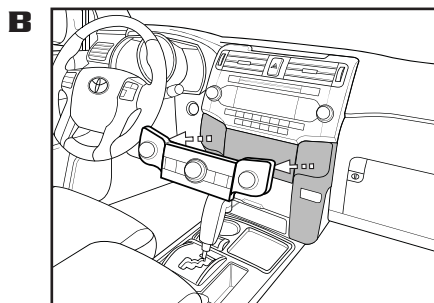
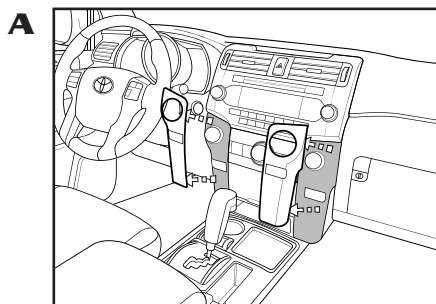

Continued on Pg. 2 .....

## 99-82275 DASH DISASSEMBLY

### TOYOTA 4 RUNNER 2010

- 4** Unclip and remove the vents from the factory radio panel. (Fig. D)
- 5** Remove the (2) Phillips screws securing the trim panel on the top of the factory radio panel. (Fig. E)
- 6** Remove the (4) Phillips screws securing the outer a/c vent control wheel trim pieces. (Fig. F)
- 7** Unclip and remove the hazard switch from the factory radio trim panel. (Fig. G)

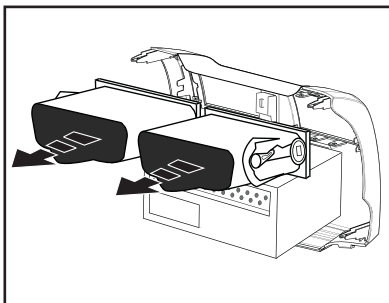
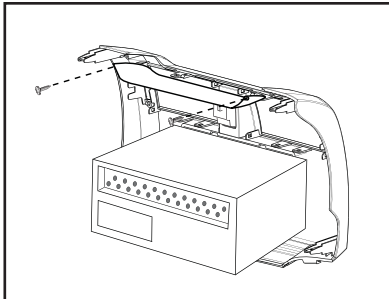
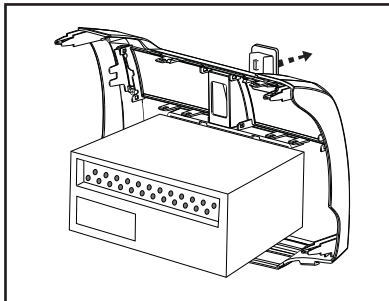
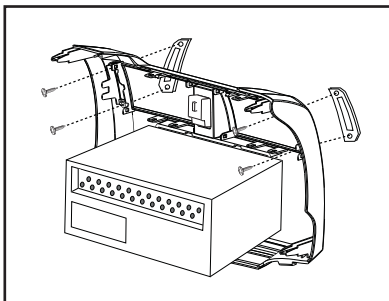
**D**

**E**

**G**

**F**

## 99-82275 KIT PREPARATION

### TOYOTA 4 RUNNER 2010

**1** Attach the outer a/c vent control wheel trim pieces to the radio housing using the factory hardware. (Fig. A)

**2** Attach the trim panel to the top of the radio housing using the factory hardware. (Fig. B)

Note: 2 screws are provided "Justin" case.

**3** Attach the a/c vents to the radio housing. (Fig. C)

**4** Snap the hazard switch into the radio housing. (Fig. D)

**5** Attach (4) panel clips to the radio housing. (Fig. D)

**A**

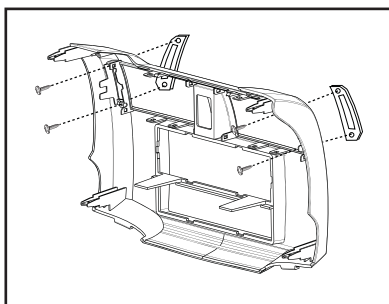

**B**

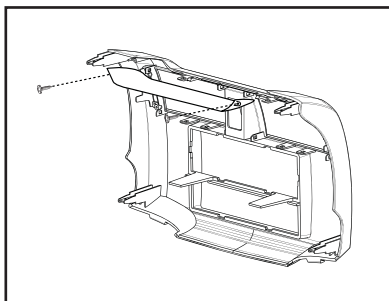

**C**

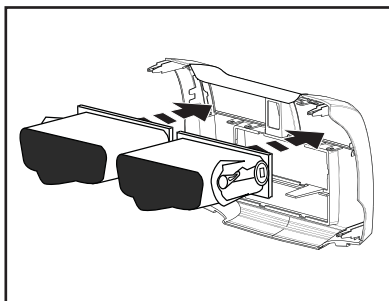

**D**

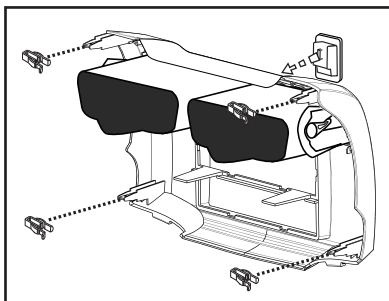

## 99-82275 KIT ASSEMBLY

### TOYOTA 4 RUNNER 2010 DIN HEAD UNIT PROVISION

- 1** Locate the factory wiring harness in the dash. Metra recommends using the proper mating adapter from Metra or AXXESS. Re-connect the negative battery terminal and test the unit for proper operation.
- 2** Slide the DIN cage into the Radio Housing and secure by bending the metal locking tabs down. (Fig. A)
- 3** Snap the pocket into the bottom opening of the radio housing. (Fig. B)
- 4** Slide the aftermarket head unit into the cage and secure. (Fig. C)
- 5** Reassemble dash in reverse order of disassembly.

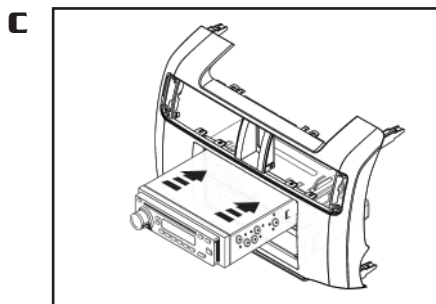
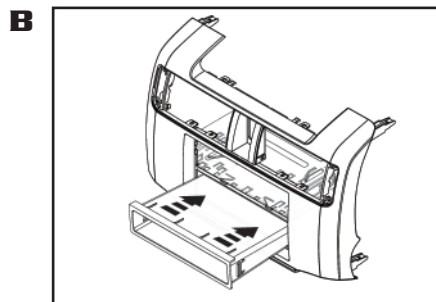
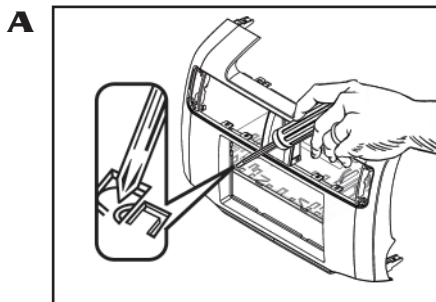



## 99-82275 KIT ASSEMBLY

### TOYOTA 4 RUNNER 2010 ISO DIN HEAD UNIT PROVISION

- 1** Locate the factory wiring harness in the dash. Metra recommends using the proper mating adapter from Metra or AXXESS. Re-connect the negative battery terminal and test the unit for proper operation.
- 2** Mount the ISO Brackets to the head unit with the screws supplied with the unit. (Fig. A)
- 3** Snap the pocket into the bottom opening of the radio housing. (Fig. B)
- 4** Slide the head unit into the radio opening until the side clips engage. (Fig. C)
- 5** Snap the Trim plate into the Radio Housing. (Fig. C)
- 6** Reassemble dash in reverse order of disassembly.

**A**

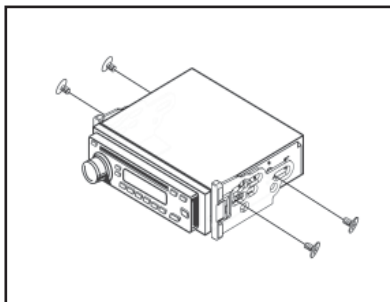

**B**

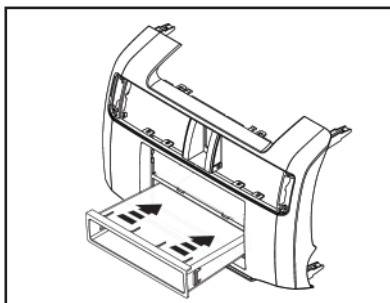

**C**

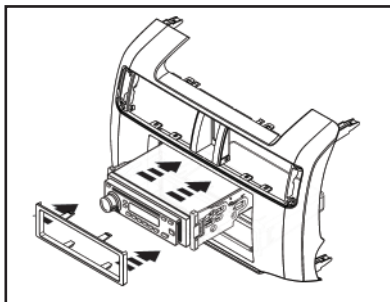



## 99-82275 KIT ASSEMBLY

### TOYOTA 4 RUNNER 2010 DOUBLE DIN HEAD UNIT PROVISION

- 1** Locate the factory wiring harness in the dash. Metra recommends using the proper mating adapter from Metra or AXXESS. Re-connect the negative battery terminal and test the unit for proper operation.
- 2** Cut and remove the center bar from the radio housing. (Fig. A)
- 3** Snap the Double DIN brackets to the inside edge of the Double DIN trim plate. (Fig. B)
- 4** Slide the Double DIN head unit or stacked ISO head units into the bracket/radio housing assembly and secure the Double DIN head unit or stacked ISO head units to the assembly using the screws supplied with the radio. (Fig. C)
- 5** Snap the double DIN trim plate into the radio housing. (Fig. C)
- 6** Reassemble dash in reverse order of disassembly.

**A**

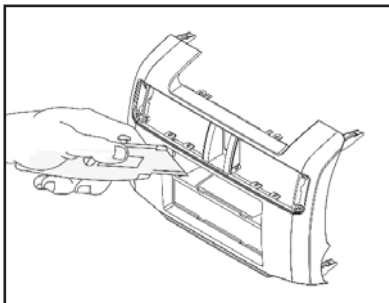

**B**

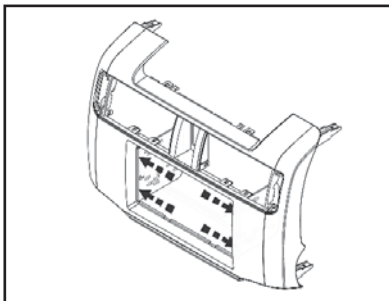

**C**

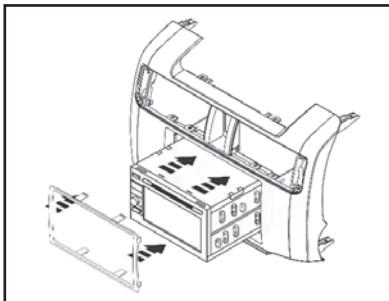







# NOTES

---

---

---

---

---

---

---

---

---

---

---

---

---

---

---

---

---

---

---

---

---

---

---

---

---

---

---

---

---





## INSTALLATION INSTRUCTIONS FOR PART 99-82275

REV. 4/01/2010

METRA. THE WORLD'S BEST KITS.™



1-800-221-0932



metraonline.com

© COPYRIGHT 2004-2010 METRA ELECTRONICS CORPORATION

Download from [Www.Somanuals.com](http://www.Somanuals.com). All Manuals Search And Download.

## Free Manuals Download Website

<http://myh66.com>

<http://usermanuals.us>

<http://www.somanuals.com>

<http://www.4manuals.cc>

<http://www.manual-lib.com>

<http://www.404manual.com>

<http://www.luxmanual.com>

<http://aubethermostatmanual.com>

Golf course search by state

<http://golfingnear.com>

Email search by domain

<http://emailbydomain.com>

Auto manuals search

<http://auto.somanuals.com>

TV manuals search

<http://tv.somanuals.com>