



INSTALLATION INSTRUCTIONS FOR PART 99-3000

APPLICATIONS

CHEVROLET:

BLAZER 92-94/PICKUP 88-94/SUBURBAN 92-94

GMC:

C-SERIES 88-94/SUBURBAN 92-94/YUKON 92-94

99-3000

AW-333GM/DW-3000/CK-333GM

99-3000

KIT FEATURES

- DIN Mount Radio Provision
- ISO Mount Radio Provision

KIT COMPONENTS

A) Radio Housing • B) ISO Brackets

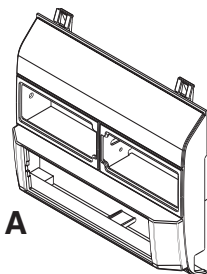

A

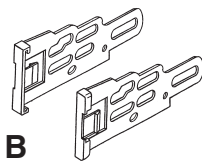

B

TOOLS REQUIRED:

- Small Flat Blade Screwdriver/ Panel Removal Tool
- Phillips Screwdriver



1-800-221-0932



www.metraonline.com

© COPYRIGHT 2004-2008 METRA ELECTRONICS CORPORATION



TABLE OF CONTENTS

***Dash Disassembly*1**

***Kit Preparation*2**

Kit Assembly

***- DIN Mount Radio Provision*3**

***- ISO Mount Radio Provision*3**

***Final Assembly*4**

****Note:***

Refer also to the instructions included with the aftermarket radio.

CHEVROLET:
BLAZER 92-94/PICKUP 88-94
SUBURBAN 92-94
GMC:
C-SERIES 88-94/SUBURBAN 92-94
YUKON 92-94

- 1 Disconnect the negative battery terminal to prevent an accidental short circuit.
- 2 Pull out on the bottom of the radio trim bezel. Unhook the top corners of the bezel and remove. (Figure A)
- 3 Remove the metal fastening clips from the bottom of the factory dash panel and attach them to the same location on the Replacement Dash Panel. (Rear inside corner view shown) (Figure B)

Continue to kit assembly.

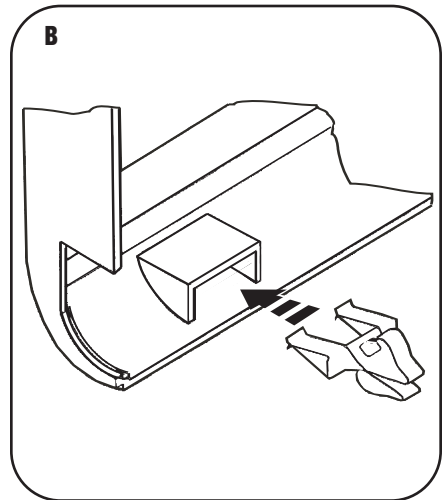
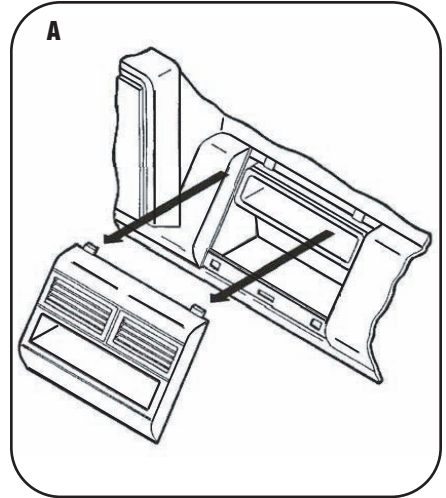

CHEVROLET:
BLAZER 92-94/PICKUP 88-94
SUBURBAN 92-94
GMC:
C-SERIES 88-94/SUBURBAN 92-94
YUKON 92-94

- 1 Remove the a/c vents from the factory dash panel by releasing the spring fastening clips securing them to the panel. Mount the vents to the Replacement Dash Panel by inserting the inner edge of the vent into the center inside pivot hole and the outer edge of the vent into the outer pivot hole. Using the same metal spring clips and mounting procedures from the original truck panel to mount the vents to the Replacement Dash Panel. (Figure A)

Continue to kit assembly.

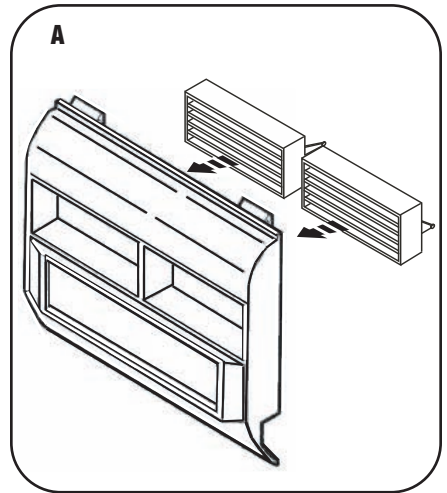

CHEVROLET:
BLAZER 92-94/PICKUP 88-94
SUBURBAN 92-94
GMC:
C-SERIES 88-94/SUBURBAN 92-94
YUKON 92-94

DIN MOUNT RADIO PROVISION

Note: Refer also to the instructions included with the aftermarket radio.

- 1 Slide the DIN cage into the radio housing and secure by bending the metal locking tabs outward. (Figure A)
- 2 Slide the aftermarket radio into the cage until it snaps into place. (Figure A)

Continue to final assembly.

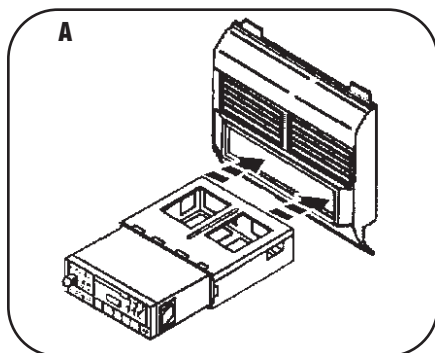

ISO MOUNT RADIO PROVISION

Note: Refer also to the instructions included with the aftermarket radio.

- 1 Mount the ISO brackets to the radio using the screws supplied with the radio.
- 2 Slide the radio into the radio housing until the ISO brackets snap into place. (Figure A)

Continue to final assembly.

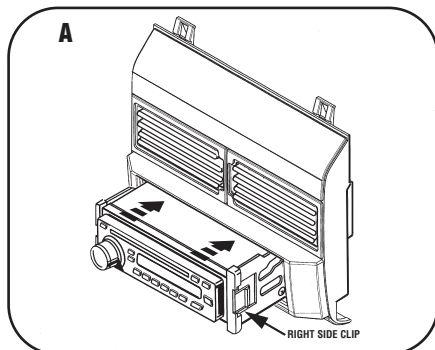

FINAL ASSEMBLY

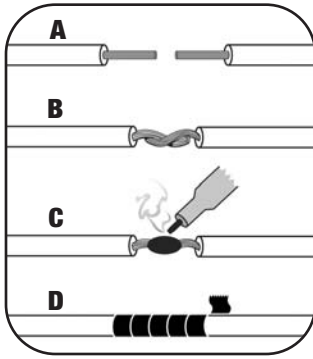

- (A) Strip wire ends back 1/2"**
- B) Twist ends together**
- C) Solder**
- D) Tape**

- 1** Locate the factory wiring harness in the dash. Metra recommends using the proper mating adapter and making connections as shown. (Isolate and individually tape off the ends of any unused wires to prevent electrical short circuit.)
- 2** Re-connect the negative battery terminal and test the unit for proper operation.
- 3** Reassemble radio and dash assemblies in reverse order of disassembly.

FINAL WIRING CONNECTIONS

Make wiring connections using the EIA color code chart shown below and the instructions included with the head unit. Metra recommends making connections as shown below; Strip, Splice, Solder, Tape. Isolate and individually tape off ends of any unused wires to prevent electrical short circuit.

METRA / EIA WIRING CODE

12V Ignition / Acc. Red	Right Front (+) Gray
12V Batt / Memory. Yellow	Right Front (-). Gray/ Black
Ground. Black*	Left Front (+) White
Power Antenna. Blue	Left Front (-). White / Black
Amp Turn-On Blue / White	Right Rear (+) Violet
Amp Ground. Black / White	Right Rear (-). Violet / Black
Illumination Orange	Left Rear (+) Green
Dimmer Orange / White	Left Rear (-). Green / Black

***NOTE:** When a Black wire is not present, ground radio to vehicle chassis.
All colors may not be present on all leads due to manufacturer's specifications.

99-3000 INSTRUCTIONS



1-800-221-0932



www.metraonline.com

REV. 03/25/08 © COPYRIGHT 2004-2008 METRA ELECTRONICS CORPORATION INST99-3000

Free Manuals Download Website

<http://myh66.com>

<http://usermanuals.us>

<http://www.somanuals.com>

<http://www.4manuals.cc>

<http://www.manual-lib.com>

<http://www.404manual.com>

<http://www.luxmanual.com>

<http://aubethermostatmanual.com>

Golf course search by state

<http://golfingnear.com>

Email search by domain

<http://emailbydomain.com>

Auto manuals search

<http://auto.somanuals.com>

TV manuals search

<http://tv.somanuals.com>