



INSTALLATION INSTRUCTIONS FOR PART 99-7878B

APPLICATIONS

HONDA Insight 2010

99-7878B

KIT FEATURES

- DIN Radio Provision with Pocket
- ISO Mount Radio Provision with Pocket
- Double DIN Radio Provision
- Stacked ISO Mount Units Provision
- **Painted A Matte Black Finish**



KIT COMPONENTS

- A) Radio Housing • B) ISO Brackets • C) ISO Trim Plate • D) Double DIN Brackets
- E) Double DIN Trim Plate • F) Pocket

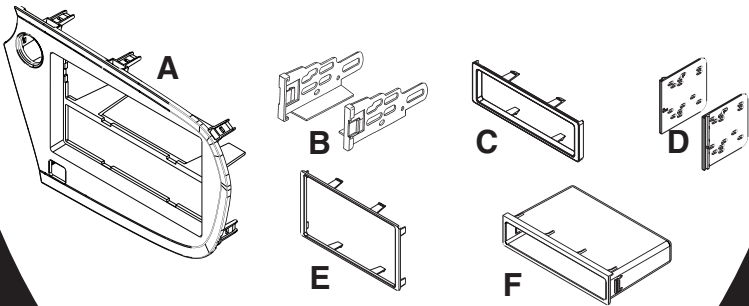

TOOLS REQUIRED:

- Small Flat Blade Screwdriver/ Panel Removal Tool
- Phillips Screwdriver • Socket Wrench

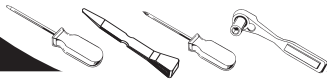

1-800-221-0932



www.metraonline.com

© COPYRIGHT 2009 METRA ELECTRONICS CORPORATION



TABLE OF CONTENTS

Dash Disassembly

- Honda Insight 20101,2

Kit Assembly

- Kit Preparation 3

- DIN Mount Radio Provision with Pocket4

- ISO Mount Radio Provision with Pocket..... 5

- Double DIN /Stacked ISO Mount Units Radio Provision6

Note:

Refer also to the instructions included with the aftermarket radio.



KNOWLEDGE IS POWER

Enhance your installation and fabrication skills by enrolling in the most recognized and respected mobile electronics school in our industry. Log onto www.installerinstitute.com or call 800-354-6782 for more information and take steps toward a better tomorrow.

HONDA INSIGHT 2010

- 1** Disconnect the negative battery terminal to prevent an accidental short circuit.
- 2** Unclip and remove the pocket/accessory socket panel below the factory radio. (Figure A)
- 3** Remove (1) 8 MM bolt facing up behind panel. Figure B)
- 4** Open the glove box then use a small blunt tool (ie: the wooden handle of a hammer) to put pressure on the back of the radio chassis to unclip and remove the radio. (Figure C)

Continued on page 2.

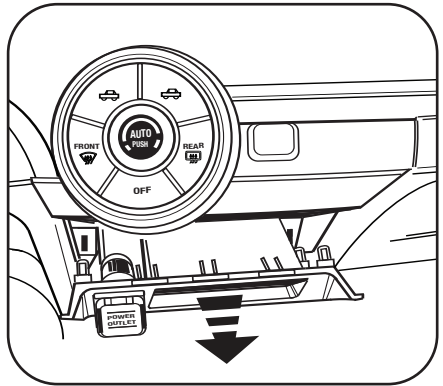
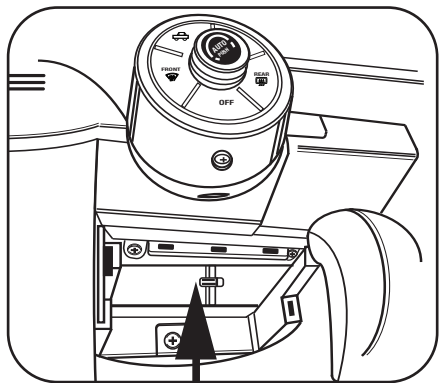
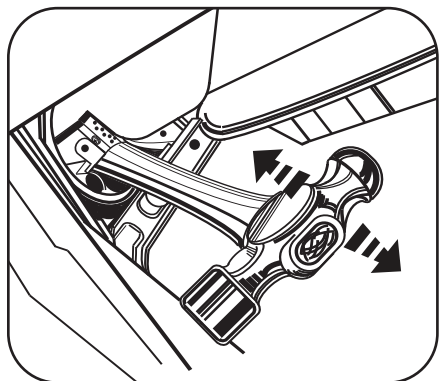
A

B

C

HONDA INSIGHT 2010

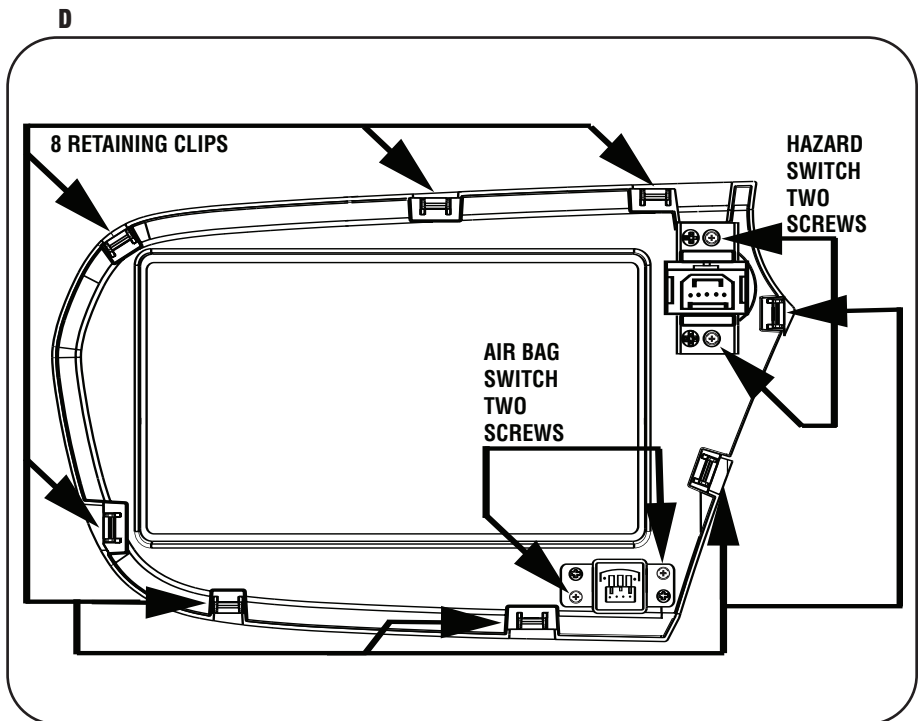
- 5 Remove (2) Phillips screws securing the hazard switch to the back of the factory radio panel. (Figure D)
- 6 Remove (2) Phillips screws securing the air bag light to the back of the factory radio panel. (Figure D)
- 7 Remove the (8) retaining clips from the factory radio panel. (Figure D)

Continue to kit preparation.



KIT PREPARATION

- 1 Secure the hazard switch into the radio housing panel using the factory hardware. (Figure A)
- 2 Secure the air bag light into the radio housing panel using the factory hardware. (Figure A)
- 3 Attach the (8) retaining clips to the radio housing panel in the same location as removed from the factory radio panel. (Figure A)

Continue to kit assembly.

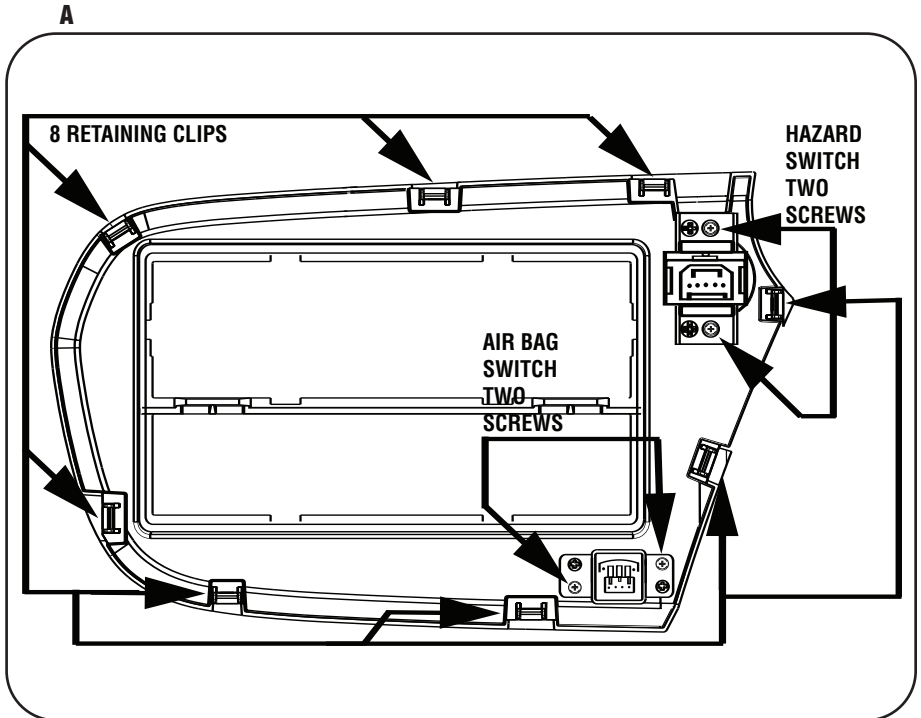

DIN MOUNT RADIO PROVISION WITH POCKET

**Note: Refer also to the instructions included with the aftermarket radio.*

- 1 Locate the factory wiring harness in the dash. Metra recommends using the proper mating adapter from Metra or AXXESS. Re-connect the negative battery terminal and test the unit for proper operation.
- 2 Slide the DIN cage into the Radio Housing and secure by bending the metal locking tabs down. (Figure A)
- 3 Snap the pocket into the bottom opening of the radio housing. (Figure B)
- 4 Slide the aftermarket head unit into the cage and secure. (Figure C)
- 5 Reassemble dash in reverse order of disassembly.

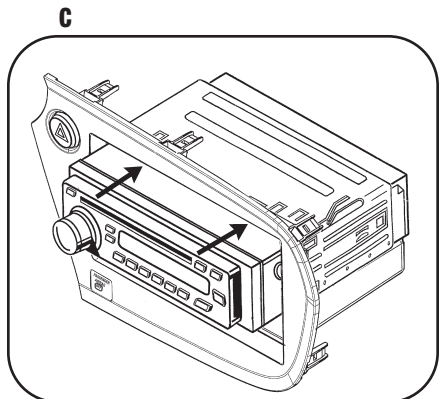
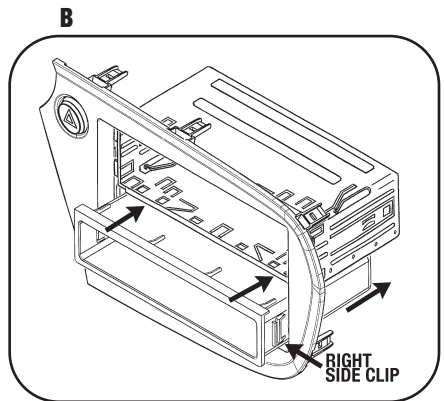
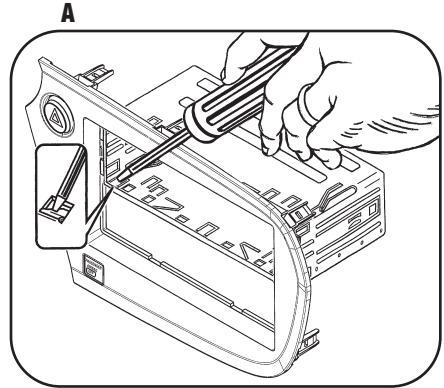

ISO MOUNT RADIO PROVISION WITH POCKET

**Note: Refer also to the instructions included with the aftermarket radio.*

- 1 Locate the factory wiring harness in the dash. Metra recommends using the proper mating adapter from Metra or AXCESS. Re-connect the negative battery terminal and test the unit for proper operation.
- 2 Mount the ISO Brackets to the head unit with the screws supplied with the unit. (Figure A)
- 3 Snap the pocket into the bottom opening of the radio housing. (Figure B)
- 4 Slide the head unit into the radio opening until the side clips engage. (Figure C)
- 5 Snap the Trim plate into the Radio Housing. (Figure C)
- 6 Reassemble dash in reverse order of disassembly.

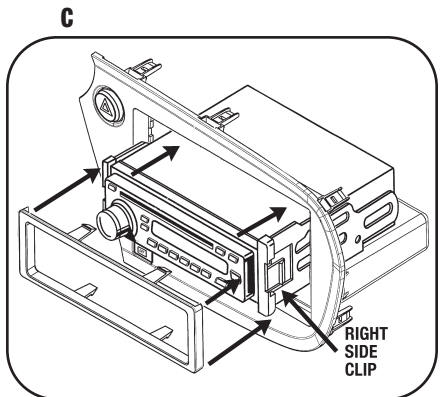
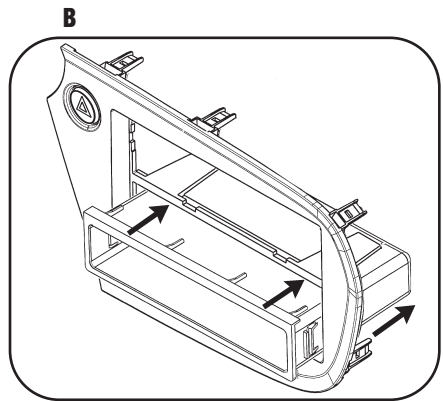
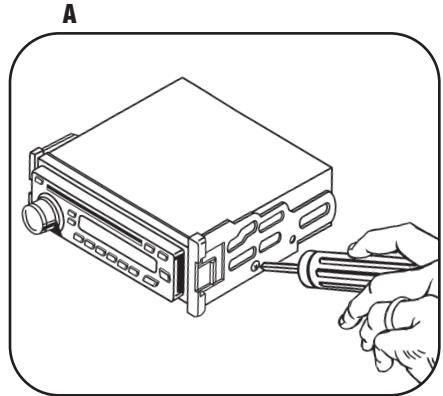

DOUBLE DIN/STACKED ISO MOUNT UNITS RADIO PROVISION

**Note: Refer also to the instructions included with the aftermarket radio.*

- 1 Locate the factory wiring harness in the dash. Metra recommends using the proper mating adapter from Metra or AXCESS. Re-connect the negative battery terminal and test the unit for proper operation.
- 2 Cut and remove the center bar from the radio housing. (Figure A)
- 3 Snap the Double DIN brackets to the inside edge of the Double DIN trim plate. (Figure B)
- 4 Slide the Double DIN head unit or stacked ISO head units into the bracket/radio housing assembly and secure the Double DIN head unit or stacked ISO head units to the assembly using the screws supplied with the radio. (Figure C)
- 5 Snap the Double DIN trim plate into the Radio Housing. (Figure C)
- 6 Reassemble dash in reverse order of disassembly.

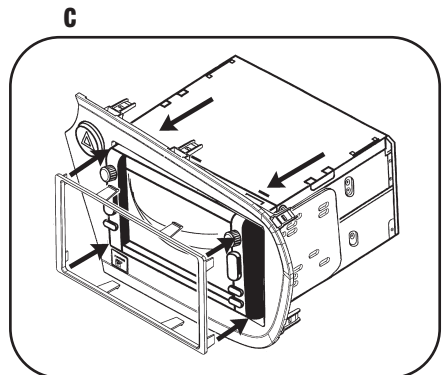
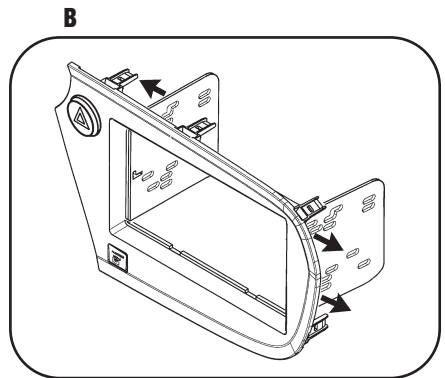
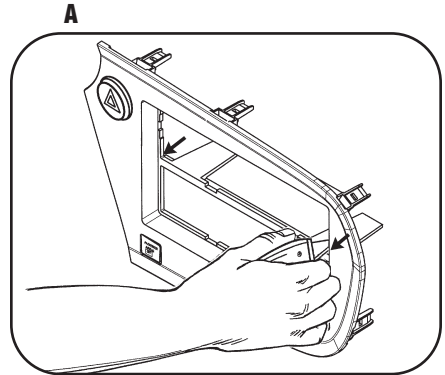
1-800-221-0932

www.metraonline.com

Free Manuals Download Website

<http://myh66.com>

<http://usermanuals.us>

<http://www.somanuals.com>

<http://www.4manuals.cc>

<http://www.manual-lib.com>

<http://www.404manual.com>

<http://www.luxmanual.com>

<http://aubethermostatmanual.com>

Golf course search by state

<http://golfingnear.com>

Email search by domain

<http://emailbydomain.com>

Auto manuals search

<http://auto.somanuals.com>

TV manuals search

<http://tv.somanuals.com>