



INSTALLATION INSTRUCTIONS FOR PART 95-5822B

APPLICATIONS

**2009-10 FORD F-150
LARIAT / KING RANCH / PLATINUM MODELS
(Not for NAV Equipped Models)**

95-5822B - BLACK

**95-5822AS - PLATINUM / ASH SATIN
95-5822CM - KING RANCH / CURLY MAPLE
95-5822MM - LARIAT / MILANO MAPLE**



KIT FEATURES

- Double DIN Head Unit Provision
- Stacked ISO DIN Head Unit Provision
- Painted or Wood Grain

KIT COMPONENTS

- A) Double DIN Radio Housing
- B) Double DIN Radio Housing Brackets
- C) Radio Housing Trim Panel
- D) (6) U Style Panel Clips

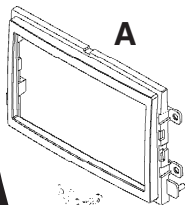

A

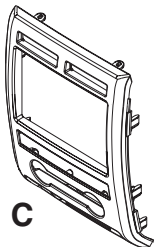

C

D



**WIRING AND ANTENNA CONNECTIONS
(Sold Separately)**

Harness:

- Please see www.metraonline.com for specific interface harness

Antenna Adapter:

- 40-CR10 - Chrysler antenna adapter 02-up

B

TOOLS REQUIRED:

- Phillips Screwdriver
- Socket Wrench
- Panel Removal Tool
- Cutting Tool
- Torx Driver



1-800-221-0932



www.metraonline.com

© COPYRIGHT 2010 METRA ELECTRONICS CORPORATION



TABLE OF CONTENTS

Dash Disassembly

- FORD F-150 2009- 10 1,2

Kit Preparation

- FORD F-150 2009-10..... 3

Kit Assembly

- Double DIN Radio Provision 4

Final Assembly 5

***Note:**

Refer also to the instructions included with the aftermarket radio.



KNOWLEDGE IS POWER

Enhance your installation and fabrication skills by enrolling in the most recognized and respected mobile electronics school in our industry. Log onto www.installerinstitute.com or call 800-354-6782 for more information and take steps toward a better tomorrow.

2009-10 FORD F-150

- 1 Disconnect the negative battery terminal to prevent an accidental short circuit.
- 2 Unclip and remove the switch panel to the right of the cigarette lighter then remove the (1) 9/32" screw exposed. (Figure A)
- 3 Remove the rubber pad at the top of the radio trim panel then remove the (2) 9/32" screws exposed. (Figure B)
- 4 Unclip and pull the side panels containing the a/c vents away from the radio trim panel. **Note: It is not necessary to remove the panels completely.** (Figure C)
- 5 Unclip and remove the radio trim panel. (Figure D)

Continued on page 2.

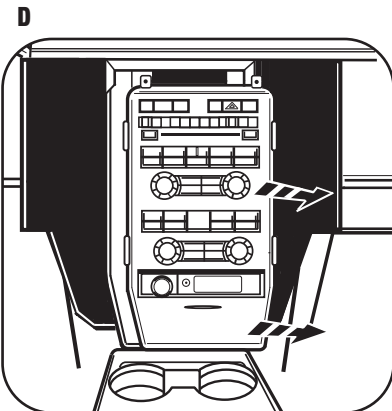
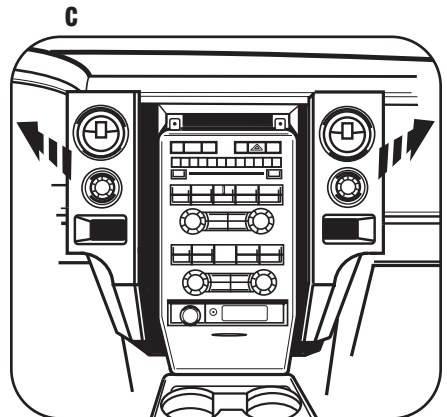
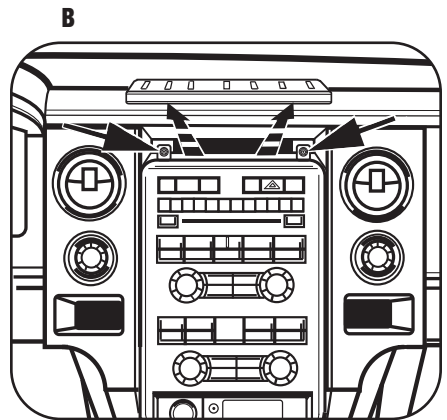
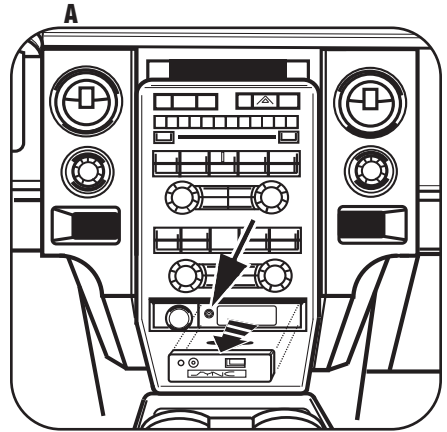

FORD F-150 2009

- 6 Unclip and remove the hazard/airbag switch and driver info switch assemblies from the factory radio trim panel. (Figure E)
- 7 Unclip and remove the cigarette lighter socket from the radio trim panel. (Figure F)
- 8 Remove (4) Torx screws securing the factory climate control to the radio trim panel. (Figure G)
- 9 Remove (4) 9/32" screws to remove the factory radio.

Continue to final preparation.

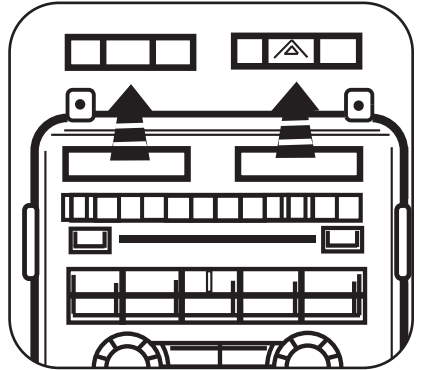
E

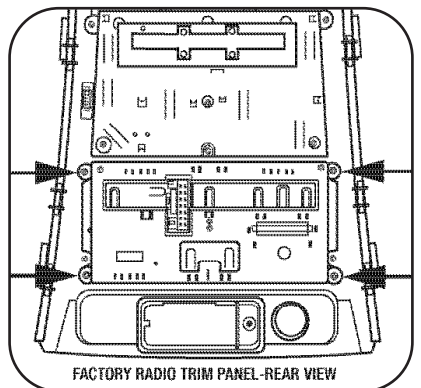
F

G

FORD F-150 2009

- 1 Clip the hazard/airbag switch and driver info switch assemblies into the radio housing in the same location as the factory radio trim panel.
- 2 Clip the cigarette lighter socket into the radio housing in the same location as the factory radio trim panel. (Figure B)
- 3 Secure the climate control into the radio housing using the factory hardware in the same location as the factory radio trim panel. (Figure C)
- 4 Attach the (6) U style panel clips to the radio housing in the same location as the factory radio trim panel. (Figure D)

Continue to kit assembly.

A

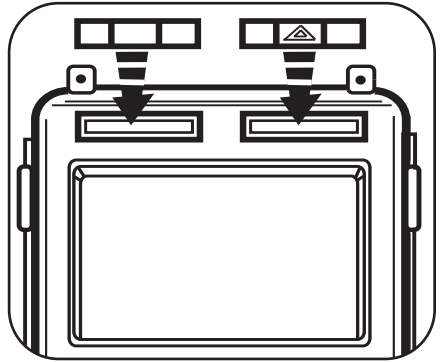

B

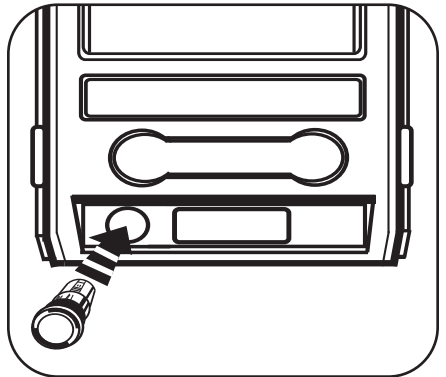

D

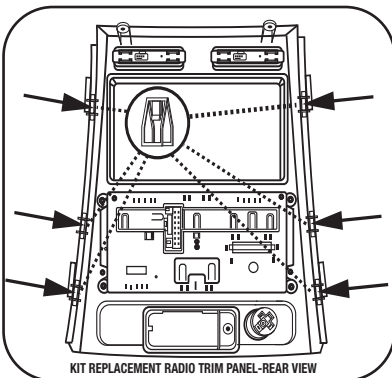

C

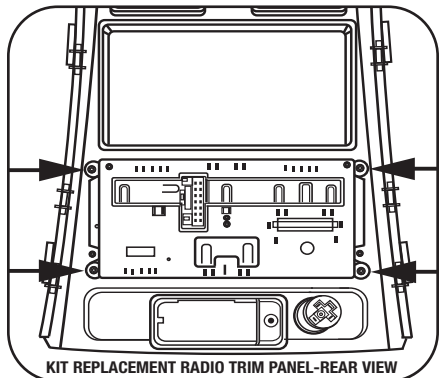

DOUBLE DIN RADIO PROVISION OR STACKED ISO MOUNT UNIT(S) PROVISION

**Note: Refer also to the instructions included with the aftermarket radio.*

- Slide the appropriate side bracket over the mounting legs of the Double DIN trim plate aligning the holes in the trim plate and the bracket and rotate inward.

Note: *The notch in the housing should be on top.* (Figure A)

- Slide the Double DIN or stacked ISO mount units into the bracket/radio housing assembly and secure the Double DIN or stacked ISO mount units to the assembly using the screws supplied with the Double DIN or stacked ISO mount units. (Figure B)

- Cut and remove half of the top (2) mounting legs with the brackets attached. (Figure C)

Continue to final assembly.

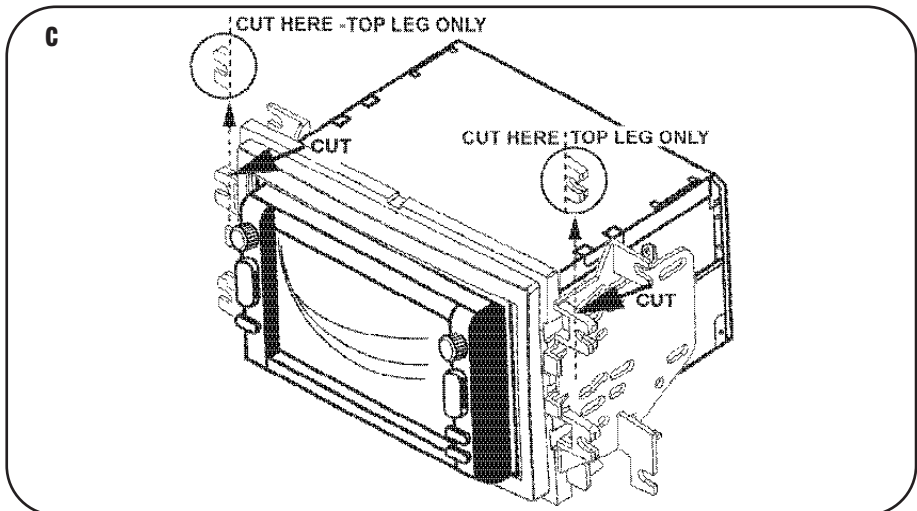
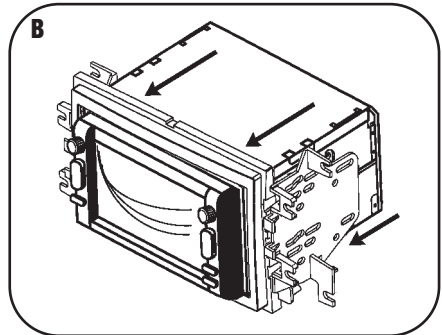
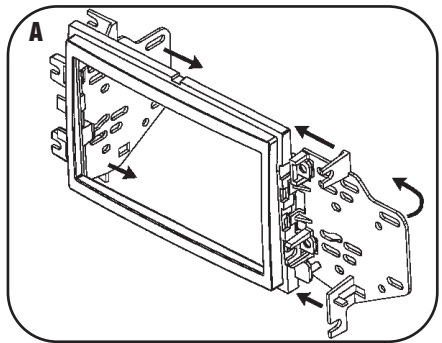

FINAL ASSEMBLY

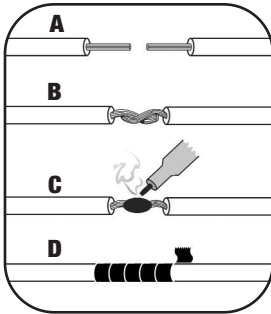

(A) Strip wire ends back 1/2"

(B) Twist ends together

(C) Solder

(D) Tape

- 1 Locate the factory wiring harness in the dash. Metra recommends using the proper mating adapter and making the connections as shown. (Isolate and individually tape off the ends of any unused wires to prevent electrical short circuit).
- 2 Re-connect the negative battery terminal and test the unit for proper operation.
- 3 Reassemble radio and dash assemblies in reverse order of disassembly using the 95-5822B radio housing in place of the factory radio trim panel.

FINAL WIRING CONNECTIONS

Make wiring connections using the EIA color code chart shown below and the instructions included with the head unit. Metra recommends making connections shown below; Strip, Splice, Solder, Tape. Isolate and individually tape off ends of any unused wires to prevent electrical short circuit.

METRA / EIA WIRING CODE

12V Ignition / Acc. Red	Right Front (+) Gray
12V Batt / Memory Yellow	Right Front (-) Gray/ Black
Ground Black*	Left Front (+) White
Power Antenna Blue	Left Front (-) White / Black
Amp Turn-On Blue / White	Right Rear (+) Violet
Amp Ground Black / White	Right Rear (-) Violet / Black
Illumination Orange	Left Rear (+) Green
Dimmer Orange / White	Left Rear (-) Green / Black

***NOTE: When a Black wire is not present, ground radio to vehicle chassis. All colors may not be present on all leads due to manufacturer's specifications.**

95-5822B INSTRUCTIONS



1-800-221-0932



www.metraonline.com

REV. 05/21/10 © COPYRIGHT 2010 METRA ELECTRONICS CORPORATION INST95-5822B

Free Manuals Download Website

<http://myh66.com>

<http://usermanuals.us>

<http://www.somanuals.com>

<http://www.4manuals.cc>

<http://www.manual-lib.com>

<http://www.404manual.com>

<http://www.luxmanual.com>

<http://aubethermostatmanual.com>

Golf course search by state

<http://golfingnear.com>

Email search by domain

<http://emailbydomain.com>

Auto manuals search

<http://auto.somanuals.com>

TV manuals search

<http://tv.somanuals.com>