

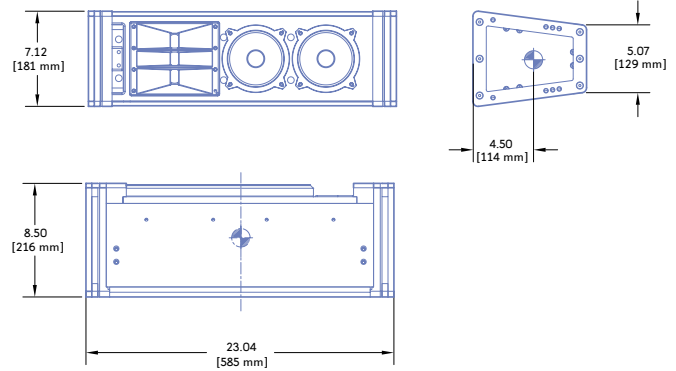

# M1D™ : Ultra-Compact Curvilinear Array Loudspeaker

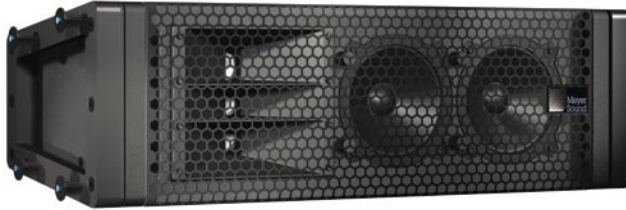

|                          |  |
|--------------------------|--|
| <b>Dimensions</b>        | 23.04" W x 7.12" H x 8.50" D<br>(585 mm x 181 mm x 216 mm) |
| <b>Weight</b>            | 31 lbs (14.06 kg); shipping: 35 lbs (15.88 kg)             |
| <b>Enclosure</b>         | Multi-ply hardwood   |
| <b>Finish</b>            | Black textured   |
| <b>Protective Grille</b> | Powder-coated hex stamped steel                            |
| <b>Rigging</b>           | QuickFly® MRF-1D rigging frame                             |

The Meyer Sound M1D ultra-compact curvilinear array loudspeaker brings the singular advantages of self-powered line arrays to sound reinforcement applications in small and mid-sized venues. The exceptionally compact enclosure enables sound designers to achieve high output, precise pattern control with very low distortion from a lightweight and unobtrusive system. The M1D provides a substantial peak SPL of 125 dB at 1 meter with an operating frequency range of 60 Hz – 18 kHz and is designed specifically for implementing vertical curvilinear arrays of up to 16 cabinets having 0- to 8-degree splay between adjacent units. This design affords the flexibility to tailor vertical coverage by varying the number and splay of cabinets in the array while maintaining a consistent 100° horizontal coverage.

The M1D loudspeaker system comprises two 5-inch cone drivers and three 0.75-inch high-frequency metal dome tweeters with neodymium magnets. To assure the smoothest response in the critical mid-range, the M1D incorporates a complex

crossover design similar to that pioneered in Meyer Sound's UPM loudspeakers. At the lowest frequencies, both 5-inch drivers combine to reproduce powerful, coherent bass. In the mid frequencies, however, the crossover feeds the signal to only one driver; this technique eliminates interference between the two drivers (that would otherwise occur at shorter wavelengths) in order to maintain optimal polar and frequency response characteristics. The three vertically aligned dome drivers act as a small line array, focusing the sound into a tight vertical coverage pattern while the constant-directivity horn maintains broad horizontal coverage.

The bi-amplified M1D incorporates a complementary MOSFET power amplifier module with 500 watts total burst capability, together with active crossover and optimized frequency and phase response correction circuitry. AC power is switchable in the range of 90 to 264 V AC, at 50 or 60 Hz. Integral peak and rms limiters protect the loudspeaker components from over-excursion and over-heating.

The M1D's vented, trapezoidal cabinet is constructed from multiply hardwood and has a textured hard shell finish. The M1D incorporates QuickFly rigging as standard, and utilizes connecting links that are secured to the steel and aluminum rigging end frames by quick release pins. An ingenious arrangement of rigging holes allows quick and easy adjustment of cabinet splay for maximum freedom in customizing vertical coverage. The optional QuickFly MG-1D multipurpose grid allows either flying or ground stacking various combinations of M1D and M1D-Sub. Up to 16 M1Ds (or the equivalent weight of M1D and M1D-Sub) with a 7:1 safety factor may be flown, or up to eight M1Ds or four M1D-Subs may be ground stacked. For flying only, the simpler optional MTG-1D will support up to 16 M1Ds (or the equivalent weight of M1D and M1D-Sub) with a 7:1 safety factor.

M1D comes equipped with Meyer Sound's RMS™ remote monitoring system as standard. RMS allows the full range of operating parameters to be monitored over a network using a Windows® computer.

## FEATURES & BENEFITS

- Extremely compact and lightweight; forms virtually "invisible" PAs
- Very flat response for exceptional accuracy and imaging
- Constant-Q horn assures uniform coverage

- Unique crossover design eliminates mid-range combing
- Seamless integration with other M Series models

## APPLICATIONS

- Compact voice reinforcement systems
- Theatrical sound reinforcement
- Portable and installed audio-visual systems
- Front and under-balcony fill

## M1D SPECIFICATIONS

|                               |  |   |
|-------------------------------|--|---|
| <b>ACOUSTICAL<sup>1</sup></b> |  | <b>Operating Frequency Range<sup>2</sup></b> 60 Hz – 18 kHz<br><b>Frequency Response<sup>3</sup></b> 75 Hz – 15 kHz $\pm 4$ dB<br><b>Phase Response</b> 800 Hz – 12 kHz $\pm 45^\circ$<br><b>Maximum Peak SPL<sup>4</sup></b> 125 dB<br><b>Dynamic Range</b> >110 dB  |
| <b>COVERAGE</b>               |  | <b>Horizontal Coverage</b> 100°<br><b>Vertical Coverage</b> Varies, depending on array length and configuration; for a single loudspeaker, 10° minimum  |
| <b>CROSSOVER<sup>5</sup></b>  |  | 1900 Hz   |
| <b>TRANSDUCERS</b>            |  | <b>Low Frequency<sup>6</sup></b> Two 5" cone drivers<br>Nominal impedance: 8 $\Omega$<br>Voice coil size: 1"<br>Power-handling capability: 200 W (AES) <sup>7</sup><br><b>High Frequency<sup>8</sup></b> Three 0.75" metal dome tweeters with neodymium magnets<br>Nominal impedance: 8 $\Omega$<br>Voice coil size: 20 mm<br>Power-handling capability: 15 W (AES) <sup>7</sup>  |
| <b>AUDIO INPUT</b>            |  | <b>Type</b> Differential, electronically balanced<br><b>Maximum Common Mode Range</b> $\pm 15$ V DC, clamped to earth for voltage transient protection<br><b>Connectors</b> Female XLR input with male XLR loop output<br><b>Input Impedance</b> 10 k $\Omega$ differential between pins 2 and 3<br><b>Wiring</b> Pin 1: Chassis/earth through 220 k $\Omega$ , 1000 pF, 15 V clamp network to provide virtual ground lift at audio frequencies<br>Pin 2: Signal +<br>Pin 3: Signal –<br>Case: Earth ground and chassis<br><b>DC Blocking</b> Differential DC blocking up to max common mode voltage<br><b>CMRR</b> >50 dB, typically 80 dB (50 Hz – 500 Hz)<br><b>RF Filter</b> Common mode: 425 kHz; Differential mode: 142 kHz<br><b>TIM Filter</b> Integral to signal processing (<80 kHz)<br><b>Nominal Input Sensitivity</b> 0 dBV (1 V rms, 1.4 V pk) continuous average is typically the onset of limiting for pink noise and music<br><b>Input Level</b> Audio source must be capable of producing a minimum of +20 dBV (10 V rms, 14 V pk) into 600 $\Omega$ in order to produce maximum peak SPL over the operating bandwidth of the loudspeaker |
| <b>AMPLIFIERS</b>             |  | <b>Type</b> Two-channel complementary MOSFET output stages (class AB/bridged)<br><b>Output Power<sup>9</sup></b> 500 W total<br><b>THD, IM, TIM</b> <.02%<br><b>Load Capacity</b> 4 $\Omega$ low channel, 2 $\Omega$ high channel<br><b>Cooling</b> Forced air cooling over amplifier heatsink  |
| <b>AC POWER</b>               |  | <b>Connector</b> PowerCon with looping output<br><b>Voltage Selection</b> Automatic<br><b>Safety Agency Rated Operating Range</b> 100 V AC – 240 V AC; 50/60 Hz<br><b>Turn-on and Turn-off Points<sup>10</sup></b> Continuous 90 V AC – 264 V AC; 50/60 Hz<br><b>Current Draw<sup>11</sup>: Idle Current</b> 0.41 A rms (115 V AC); 0.33 A rms (230 V AC); 0.42 A rms (100 V AC)<br><b>Max Long-Term Continuous Current (&gt;10 sec)</b> 3.2 A rms (115 V AC); 1.6 A rms (230 V AC); 3.7 A rms (100 V AC)<br><b>Burst Current (&lt;1 sec)</b> 5.0 A rms (115 V AC); 2.5 A rms (230 V AC); 5.8 A rms (100 V AC)<br><b>Ultimate Short-Term Peak Current Draw</b> 17 A pk (115 V AC); 8.5 A pk (230 V AC); 20 A pk (100 V AC)<br><b>Inrush Current</b> 15 A pk (115 V AC); 13 A pk (230 V AC); 15 A pk (100 V AC)  |
| <b>RMS NETWORK</b>            |  | Equipped for two conductor twisted-pair network, reporting all operating parameters of amplifiers to system operator's host computer.   |

### NOTES:

- The low-frequency power response of the system will increase according to the length of the array.
- Recommended maximum operating frequency range. Response depends on loading conditions and room acoustics.
- Free field, measured with 1/3 octave frequency resolution at 4 meters.
- Measured with music at 1 meter.
- At these frequencies, the transducers produce equal sound pressure levels.
- To eliminate interference at short wavelengths, the two 5-inch drivers work in combination at low frequencies (60 Hz – 1000 Hz). At mid frequencies (1000 Hz – 1900 Hz) only one cone driver is fed from the crossover to maintain optimal polar and frequency response characteristics.
- Power handling is measured under AES standard conditions: transducer driven continuously for two hours with band-limited noise signal having a 6 dB peak-average ratio.
- The three drivers are coupled to a constant-directivity horn.
- Wattage rating is based on the maximum unclipped burst sine-wave rms voltage that the amplifier will produce into the nominal load impedance. Low channel: 30 V rms (42 V pk); high channel: 27 V rms (38 V pk)
- No automatic turn-off voltages. Voltages above 264 V AC are fuse protected but may cause permanent damage to the power supply. Voltages below 90 V AC may result in intermittent operation.
- Current draw for a single loudspeaker. Loop out not used.



M1D – 04.115.001.01

Copyright © 2003  
Meyer Sound Laboratories Inc.  
All rights reserved

**MEYER SOUND LABORATORIES INC.**  
2832 San Pablo Avenue  
Berkeley, CA 94702

T: +1 510 486.1166  
F: +1 510 486.8356

techsupport@meyersound.com  
www.meyersound.com

## ARCHITECT SPECIFICATIONS

The loudspeaker shall be a self-powered, full-range system for deployment in vertical curvilinear array systems. The low-frequency transducers shall consist of two 5-inch cone drivers with 1-inch voice coil. The high-frequency transducers shall be three 0.75-inch metal dome tweeters coupled via a custom manifold to a 100° horizontal constant directivity horn.

The loudspeaker shall incorporate internal processing electronics and a two-channel amplifier. Processing functions shall include equalization, phase correction, driver protection and signal division for the high- and low-frequency sections. The crossover point (equal sound pressure levels between high and low frequency transducers) shall be 1900 Hz. An additional passive low-frequency crossover shall cause the two low-frequency transducers to work in combination between 60 and 1000 Hz, with only one working between 1000 Hz and 1900 Hz, to maintain optimal polar response characteristics.

Each amplifier channel shall be class AB/bridged with complementary MOSFET output stages. Burst capability shall

be 500 watts total. Distortion (THD, IM, TIM) shall not exceed 0.02%. Protection circuits shall include peak and rms limiting. The audio input shall be electronically balanced with a 10 k $\Omega$  impedance and accept a nominal 0 dBV (1 V rms, 1.4 V pk) signal (+20 dBV to produce maximum SPL). Connectors shall be XLR (A-3) type male and female. RF filtering shall be provided, and CMRR shall be greater than 50 dB (80 dB, 50 – 500 Hz).

Performance specifications for a typical production unit shall be as follows, measured at 1/3 octave resolution: Operating frequency range shall be 60 Hz to 18 kHz. Phase response shall be  $\pm 45^\circ$  from 800 Hz to 12 kHz. Maximum SPL shall be 125 dB at 1 m. Beamwidth shall be 100° horizontal. Vertical coverage in multi-cabinet arrays shall be dependent on system configuration; for a single cabinet, the minimum shall be 10°.

The internal power supply shall perform automatic voltage selection, EMI filtering, and surge suppression. Powering requirements shall be nominal 90 V AC to 264 V AC line cur-

rent at 50 Hz or 60 Hz. UL and CE operating voltage range shall be 100 V AC to 240 V AC. Current draw during burst shall be 5 A rms at 115 V AC, 2.5 A rms at 230 V AC and 5.8 A rms at 100 V AC. Inrush current during turn-on shall not exceed 15 A at 115 V AC. AC power connectors shall be PowerCon with looping output.

The loudspeaker system shall incorporate the electronics module for Meyer Sound's RMS remote monitoring system.

All loudspeaker components shall be mounted in an enclosure constructed of multi-ply hardwood with a black textured finish. The front protective grille shall be powder-coated, hex stamped steel. Dimensions shall be 23.04" wide x 7.12" high x 8.50" deep (585 mm x 181 mm x 216 mm). Weight shall be 31 lbs (14 kg).

The loudspeaker shall be the Meyer Sound M1D.

## Free Manuals Download Website

<http://myh66.com>

<http://usermanuals.us>

<http://www.somanuals.com>

<http://www.4manuals.cc>

<http://www.manual-lib.com>

<http://www.404manual.com>

<http://www.luxmanual.com>

<http://aubethermostatmanual.com>

Golf course search by state

<http://golfingnear.com>

Email search by domain

<http://emailbydomain.com>

Auto manuals search

<http://auto.somanuals.com>

TV manuals search

<http://tv.somanuals.com>