

M2D Compact Curvilinear Array Loudspeaker
M2D-Sub Compact Subwoofer



***Keep these important operating instructions.
Check www.meyersound.com for updates.***

DECLARATION OF CONFORMITY ACCORDING TO ISO/IEC GUIDE 22 AND EN 45014

Manufacturer's Name:

Meyer Sound Laboratories Inc.

Manufacturer's Address:

2832 San Pablo Avenue
Berkeley, CA 94702-2204, USA

Declares that the products

Product Name: M2D and M2D-Sub Loudspeakers

Product Options: All

Safety: IEC 60065:1998
EN 60065:1998
UL 6500/09.99
CAN/CSA E60065-00

EMC: EN 55103-1: 1997 emission(1)
EN 55103-2: 1997 immunity(2)

This device complies with EN 55103-1 & -2. Operation is subject to the following two conditions:

- (1) this device may not cause harmful interference, and
- (2) this device must accept any interference received, including interference that may cause undesired operation.

Supplementary Information

The product herewith complies with the requirements of the Low Voltage Directive 73/23/EEC and the EMC Directive 89/336/EEC.

Office of Quality Manager
Berkeley, California USA
October 28, 2003

European Contact: Your local Meyer Sound dealer or Meyer Sound Germany, GmbH. Carl Zeiss Strasse 13, 56751 Polch, Germany.
Telephone: 49.2654.9600.58 Fax: 49.2654.9600.59

Environmental specifications for Meyer Sound Electronics products

Operating Temperature	0° C to + 45° C
Non operating Temperature	<-40° C or > +75° C
Humidity	to 95% at 35° C
Operating Altitude	to 4600 m (15,000 ft)
Non operating Altitude	to 6300 m (25,000 ft)
Shock	30 g 11 msec half-sine on each of 6 sides
Vibration	10 Hz to 55 Hz (0.010 m peak-to-peak excursion)



Made by Meyer Sound Laboratories
Berkeley, California USA
European Office:
Meyer Sound Lab. GmbH
Carl Zeiss Strasse 13
56751 Polch, Germany



COPYRIGHT

© 2004 Meyer Sound. All rights reserved.

M2D Compact Curvilinear Array Loudspeaker/M2D-Sub Compact Subwoofer Operating Instructions

The contents of this manual are furnished for informational purposes only, are subject to change without notice, and should not be construed as a commitment by Meyer Sound Laboratories Inc. Meyer Sound assumes no responsibility or liability for any errors or inaccuracies that may appear in this manual. Except as permitted by applicable copyright law, no part of this publication may be reproduced, stored in a retrieval system, or transmitted, in any form or by any means, electronic, mechanical, recording or otherwise, without prior written permission from Meyer Sound.

M Series, M2D, RMS, REM, VEAM, Intelligent AC and all alphanumeric product designations are trademarks of Meyer Sound. Meyer Sound, Meyer Sound MAPP Online, SIM, TruPower and QuickFly are registered trademarks of Meyer Sound Laboratories Inc. (Reg. U.S. Pat. & Tm. Off.). All third-party trademarks mentioned herein are the property of their respective trademark holders.





Meyer Sound's REM™ ribbon emulation manifold is the subject of US patent #6,668,969.

Printed in the U.S.A.

Part Number: 05.112.012.01, Rev A

SYMBOLS USED

These symbols indicate important safety or operating features in this booklet and on the chassis:

			
Dangerous voltages: risk of electric shock	Important operating instructions	Frame or chassis	Protective earth ground
Pour indiquer les risques résultant de tensions dangereuses	Pour indiquer important instructions	Masse, châssis	Terre de protection
Zu die gefahren von gefährliche spanning zeigen	Zu wichtige betriebsanweisung und unterhaltsanweisung zeigen	Rahmen oder chassis	Die schutzerde
Para indicar voltajes peligrosos.	Instrucciones importantes de funcionamiento y/o mantenimiento	Armadura o chassis	Tierra proteccionista

IMPORTANT SAFETY INSTRUCTIONS

1. Read these instructions.
 2. Keep these instructions.
 3. Heed all warnings.
 4. Follow all instructions.
 5. Do not use this loudspeaker near water.
 6. Clean only with dry cloth.
 7. Do not block any ventilation openings. Install in accordance with Meyer Sound's installation instructions.
 8. Do not install near any heat sources such as radiators, heat registers, stoves, or other apparatus that produce heat.
 9. Do not defeat the safety purpose of the grounding-type plug. A grounding type plug has two blades and a third grounding prong. The third prong is provided for your safety. If the provided plug does not fit into your outlet, consult an electrician for replacement of the obsolete outlet.
 10. Protect the power cord from being walked on or pinched, particularly at plugs, convenience receptacles, and the point where they exit from the loudspeaker. The AC mains plug or appliance coupler shall remain readily accessible for operation.
 11. Only use attachments/accessories specified by Meyer Sound.
 12. Use only with the caster rails or rigging specified by Meyer Sound, or sold with the loudspeaker. Handles are for carrying only.
-
- 

CAUTION: Rigging should only be done by experienced professionals.
-
13. Unplug this loudspeaker during lightning storms or when unused for long periods of time.
 14. Refer all servicing to qualified service personnel. Servicing is required when the loudspeaker has been damaged in any way, such as when the power-supply cord or plug has been damaged; liquid has been spilled or objects have fallen into the loudspeaker; rain or moisture has entered the loudspeaker; the loudspeaker has been dropped; or when for undetermined reasons the loudspeaker does not operate normally.

SAFETY SUMMARY

English

- To reduce the risk of electric shock, disconnect the loudspeaker from the AC mains before installing audio cable. Reconnect the power cord only after making all signal connections.
- Connect the loudspeaker to a two-pole, three-wire grounding mains receptacle. The receptacle must be connected to a fuse or circuit breaker. Connection to any other type of receptacle poses a shock hazard and may violate local electrical codes.
- Do not install the loudspeaker in wet or humid locations without using weather protection equipment from Meyer Sound.
- Do not allow water or any foreign object to get inside the loudspeaker. Do not put objects containing liquid on or near the unit.
- To reduce the risk of overheating the loudspeaker, avoid exposing it to direct sunlight. Do not install the unit near heat-emitting appliances, such as a room heater or stove.
- This loudspeaker contains potentially hazardous voltages. Do not attempt to disassemble the unit. The unit contains no user-serviceable parts. Repairs should be performed only by factory-trained service personnel.

Français

- Pour réduire le risque d'électrocution, débrancher la prise principale de l'haut-parleur, avant d'installer le câble d'interface allant à l'audio. Ne rebrancher le bloc d'alimentation qu'après avoir effectué toutes les connections.
- Branchez l'haut-parleur dans une prise de courant à 3 dérivations (deux pôles et la terre). Cette prise doit être munie d'une protection adéquate (fusible ou coupe-circuit). Le branchement dans tout autre genre de prise pourrait entraîner un risque d'électrocution et peut constituer une infraction à la réglementation locale concernant les installations électriques.
- Ne pas installer l'haut-parleur dans un endroit où il y a de l'eau ou une humidité excessive.

- Ne pas laisser de l'eau ou tout objet pénétrer dans l'haut-parleur. Ne pas placer de récipients contenant un liquide sur cet appareil, ni à proximité de celui-ci.
- Pour éviter une surchauffe de l'haut-parleur, conserver-la à l'abri du soleil. Ne pas installer à proximité d'appareils dégageant de la chaleur tels que radiateurs ou appareils de chauffage.
- Ce haut-parleur contient des circuits haute tension présentant un danger. Ne jamais essayer de le démonter. Il n'y a aucun composant qui puisse être réparé par l'utilisateur. Toutes les réparations doivent être effectuées par du personnel qualifié et agréé par le constructeur.

Deutsch

- Um die Gefahr eines elektrischen Schlages auf ein Minimum zu reduzieren, den Lautsprecher vom Stromnetz trennen, bevor ggf. ein Audio-Schnittstellensignalkabel angeschlossen wird. Das Netzkabel erst nach Herstellung aller Signalverbindungen wieder einstecken.
- Der Lautsprecher an eine geerdete zweipolige Dreiphasen-Netzsteckdose anschließen. Die Steckdose muß mit einem geeigneten Abzweigschutz (Sicherung oder Leistungsschalter) verbunden sein. Der Anschluß der unterbrechungsfreien Stromversorgung an einen anderen Steckdosentyp kann zu Stromschlägen führen und gegen die örtlichen Vorschriften verstoßen.
- Der Lautsprecher nicht an einem Ort aufstellen, an dem sie mit Wasser oder übermäßig hoher Luftfeuchtigkeit in Berührung kommen könnte.
- Darauf achten, daß weder Wasser noch Fremdkörper in das Innere den Lautsprecher eindringen. Keine Objekte, die Flüssigkeit enthalten, auf oder neben die unterbrechungsfreie Stromversorgung stellen.
- Um ein Überhitzen dem Lautsprecher zu verhindern, das Gerät vor direkter Sonneneinstrahlung fernhalten und nicht in der Nähe von wärmeabstrahlenden

Haushaltsgeräten (z.B. Heizgerät oder Herd) aufstellen.

- Im Inneren diesem Lautsprecher herrschen potentiell gefährliche Spannungen. Nicht versuchen, das Gerät zu öffnen. Es enthält keine vom Benutzer reparierbaren Teile. Reparaturen dürfen nur von ausgebildetem Kundendienstpersonal durchgeführt werden.

Español

- Para reducir el riesgo de descarga eléctrica, desconecte de la red de voltaje el altoparlante antes de instalar el cable de señal de audio. Vuelva a conectar la alimentación de voltaje una vez efectuadas todas las interconexiones de señalización de audio.
- Conecte el altoparlante a un tomacorriente bipolar y trifilar con neutro de puesta a tierra. El tomacorriente debe estar conectado a la protección de derivación apropiada (ya sea un fusible o un disyuntor). La conexión a cualquier otro tipo de tomacorriente puede constituir peligro de descarga eléctrica y violar los códigos eléctricos locales.
- No instale el altoparlante en lugares donde haya agua o humedad excesiva.
- No deje que en el altoparlante entre agua ni ningún objeto extraño. No ponga objetos con líquidos encima de la unidad ni cerca de ella.
- Para reducir el riesgo de sobrecalentamiento, no exponga la unidad a los rayos directos del sol ni la instale cerca de artefactos que emiten calor, como estufas o cocinas.
- Este altoparlante contiene niveles de voltaje peligrosos en potencia. No intente desarmar la unidad, pues no contiene piezas que puedan ser reparadas por el usuario. Las reparaciones deben efectuarse únicamente por parte del personal de mantenimiento capacitado en la fábrica.

CONTENTS

INTRODUCTION	1
How to Use this Manual	1
Introducing the M2D and M2D-Sub Loudspeakers	1
CHAPTER 1: Power Requirements	3
AC Power	3
AC Power Distribution	3
Power Connector Wiring	4
Voltage and Current Requirements	5
M2D Voltage Requirements	5
M2D Current Requirements	5
M2D-Sub Voltage Requirements	6
M2D-Sub Current Requirements	6
CHAPTER 2: Amplification and Audio	9
Audio Input	9
M2D Interconnections	10
M2D Amplification	10
M2D Limiting	10
M2D Amplifier Cooling System	11
Optional Fan Assembly Kit	11
M2D-Sub Interconnections	11
M2D-Sub Amplification	12
M2D-Sub Limiting	12
M2D-Sub Amplifier Cooling System	13
CHAPTER 3: RMS™ Remote Monitoring System	15
Understanding the RMS User Panel	15
Service LED (Red)	15
Service Button	16
Wink LED (green)	16
Reset Button	16
Activity LED (Green)	16
User Interface	16
CHAPTER 4: Line Arrays and System Integration	17
How Line Arrays Work	17
The M2D Line Array	17
High Frequencies	17
Mid to Low Frequencies	17
Adjusting Line Array Coverage	17
High-Frequency Design Strategies	18
Low-Frequency Design Strategies	18
Electronically Driving the Array	18
High-Frequency Equalization Strategies	18
Low-Frequency Strategies	18
Using the M2D-Sub with the M2D	19
Daisy-Chained	20

Adding a Line Driver	20
Engaging the Lo-Cut Filter	20
Using the LD-3	21
Digital Signal Processors	21
Using the 650-P with the M2D	21
CHAPTER 5: System Design and Integration tools	23
Meyer Sound MAPP Online®	23
SIM® Measurement System	24
Source Independent Measurement Technique	24
Applications	24
CHAPTER 6: QuickFly® Rigging	25
MG-2D Multipurpose Grid	25
MG-1D Multipurpose Grid	26
APPENDIX A	27
Troubleshooting	27
APPENDIX B	29
M2D Specifications	29
M2D-Sub Specifications	31

INTRODUCTION

HOW TO USE THIS MANUAL

As you read this manual, you'll find figures and diagrams to help you understand and visualize what you're reading. You'll also find numerous icons that serve as cues to flag important information or warn you against improper or potentially harmful activities. These icons include:



A **NOTE** identifies an important or useful piece of information relating to the topic under discussion.



A **TIP** offers a helpful tip relevant to the topic at hand.



A **CAUTION** gives notice that an action can have serious consequences and could cause harm to equipment or personnel, delays, or other problems.

INTRODUCING THE M2D AND M2D-SUB LOUSPEAKERS

As part of Meyer Sound's M Series, the M2D compact curvilinear array loudspeaker and M2D-Sub compact subwoofer bring numerous advantages to mid-sized venues that require tight vertical pattern control with long throw. Self-powered, with QuickFly® rigging and Meyer Sound's RMS™ remote monitoring system as standard, the M2D and M2D-Sub loudspeakers can be deployed as a self-contained system or configured along with other Meyer Sound loudspeakers in more complex systems.

Operating at a frequency range of 60 Hz to 16 kHz, the M2D loudspeaker's compact enclosure (Figure i.1) is designed specifically for vertical curvilinear arrays of up to 16 cabinets having 0- to 7-degree splay between units in 1-degree increments.



Figure i.1. M2D compact curvilinear array loudspeaker

The M2D loudspeaker gives you the flexibility to tailor vertical coverage by varying the number and splay of cabinets in the array while maintaining a constant 90 degrees of horizontal coverage. For high frequencies, the M2D loudspeaker utilizes Meyer Sound's patented REM™ ribbon emulation manifold to couple a single compression driver with a 1.5-inch exit (4-inch diaphragm) to a horn with 90-degree constant-directivity horizontal coverage. (The vertical coverage of the array depends upon the array length and curvature). The M2D loudspeaker's mid-low section comprises two high-power 10-inch drivers with lightweight neodymium magnet assemblies housed in a compact, vented trapezoidal enclosure.

In addition, to assure the smoothest response in the critical midrange, the M2D loudspeaker incorporates a complex crossover design. At the lowest frequencies, both 10-inch drivers combine to reproduce powerful, coherent bass, while in the mid frequencies the crossover feeds only one of the two drivers. This ingenious technique eliminates interference between the drivers that would otherwise occur at shorter wavelengths near the crossover frequencies.

The companion M2D-Sub subwoofer (Figure i.2), designed specifically to work with the M2D, extends overall system power bandwidth and frequency range down to 28 Hz.



Figure i.2. M2D-Sub compact subwoofer

With an operating frequency range of 28 Hz to 160 Hz, the dual 15-inch M2D-Sub loudspeaker complements the M2D loudspeaker in reinforcement applications requiring extended low-frequency headroom.

The M2D-Sub loudspeaker affords 138 dB SPL peak output capability. It employs two Meyer Sound ferrofluid cooled, back-vented drivers each featuring a 4-inch voice coil with a lightweight neodymium magnet structure. Each driver is rated to handle 1200 AES watts.



NOTE: Power handling is measured under AES standard conditions: Transducer driven continuously for two hours with band-limited noise signal having a 6 dB peak-average ratio.

An integral two-channel class AB/H complementary MOSFET amplifier provides very high burst capability, and Intelligent AC performs automatic voltage selection, allowing the unit to accommodate worldwide mains voltages without manually setting a voltage switch.

Integral peak and rms limiters featuring Meyer Sound's TruPower® limiting technology protect M2D-Sub components from over-excursion and over-heating while assuring minimal power compression and maximum peak headroom.

The M2D and M2D-Sub loudspeakers are fitted with Meyer Sound's RMS remote monitoring system, allowing the full range of operating parameters to be monitored continuously over a network using a Windows® computer. In addition, both loudspeakers are supported by the Meyer Sound MAPP Online® multipurpose acoustical prediction program for easy and accurate system design. The MAPP Online prediction program allows quick prediction of coverage, frequency response, impulse response and maximum output of arrayed loudspeakers, and more.



NOTE: See Chapter 4, "Remote Monitoring System," and Chapter 5, "System Design and Integration Tools," for more information about the RMS monitoring system and the MAPP Online prediction program.



NOTE: Read this entire manual carefully before configuring and deploying your M2D and M2D-Sub system. In particular, pay careful attention to the sections about safety issues.

Information and specifications are applicable as of the date of this printing. Updates and supplementary information are posted on the Meyer Sound web site at:

<http://www.meyersound.com>

You may contact Meyer Sound Technical Support at:

Tel: +1 510 486.1166

Fax: +1 510 486.8356

Email: techsupport@meyersound.com

CHAPTER 1: POWER REQUIREMENTS

The M2D and M2D-Sub loudspeakers represent advanced technology with equally advanced power capabilities. Understanding power distribution, voltage and current requirements, as well as electrical safety issues, is critical to their safe operation and deployment.

AC POWER

The M2D and M2D-Sub loudspeakers use a PowerCon® 3-pole AC mains system with locking connectors to prevent accidental disconnection or a multipin VEAM™ male power connector (Figures 1.1, 1.2 and 1.3).

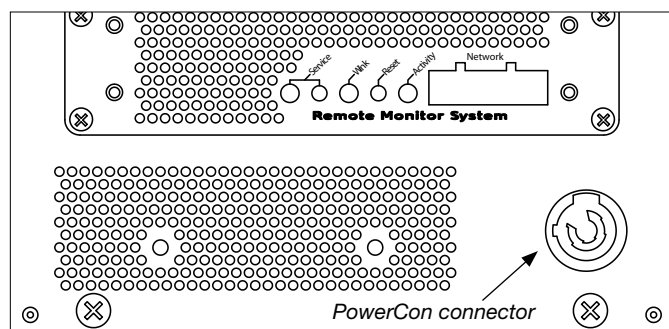

Figure 1.1. M2D user panel with PowerCon connector

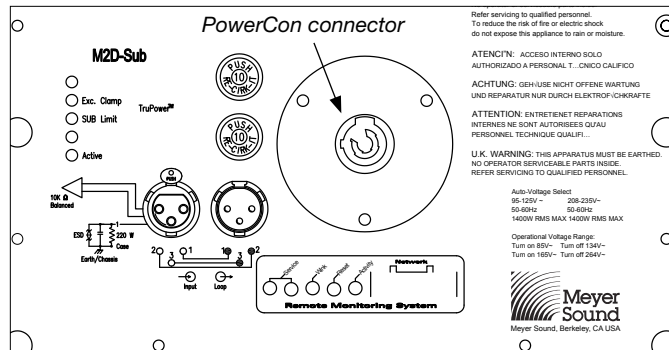

Figure 1.2. M2D-Sub user panel with PowerCon connector

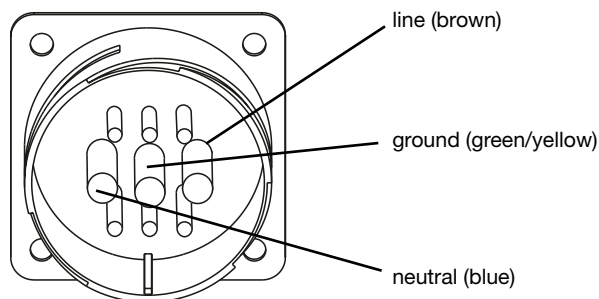

Figure 1.3. Optional VEAM multipin connector power pin-out

CAUTION: Ensure that you select the correct power plug for the AC power in the area in which you use your loudspeaker.

When AC power is applied to the M2D or M2D-Sub loudspeaker, the Intelligent AC power supply automatically selects the correct operating voltage, allowing the loudspeakers to be used internationally without manually setting voltage switches. The Intelligent AC supply performs the following protective functions to compensate for hostile conditions on the AC mains:

- Suppresses high-voltage transients up to several kilovolts
- Filters common mode and difference mode radio frequencies (EMI)
- Sustains operation temporarily during low-voltage periods
- Provides soft-start power-up, which eliminates high inrush current

AC Power Distribution

All amplifier modules and directly associated audio equipment (mixing consoles, processors, etc.) must be connected to the AC power distribution in a proper manner, preserving AC line polarity and connecting earth ground such that all grounding points are connected to a single node or common point using the same cable gauge as the neutral and line(s) cable(s).

Improper grounding connections between loudspeakers and the rest of the audio system may produce noise, hum and/or serious damage to the input/output stages in the system's electronic equipment.

CAUTION: Before applying AC to any Meyer Sound self-powered loudspeaker, be sure that the voltage potential difference between neutral and earth ground is less than 5 volts AC.

Figure 1.4 shows a sample three-phase AC distribution system, with the load between loudspeakers distributed among the three phases and all of the loudspeakers connected to common neutral and earth ground points.

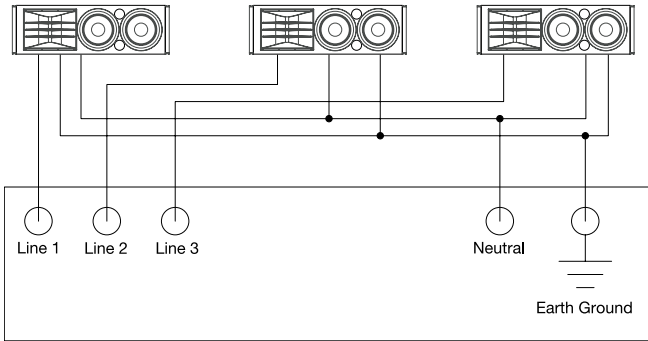

Figure 1.4. A sample AC power distribution block diagram

CAUTION: Continuous voltages higher than 265 volts can damage the unit.

TIP: Since M2D and M2D-Sub loudspeakers do not require a dedicated Neutral, and can tolerate elevated voltages from ground, they can be connected between line-line terminals in a 120 volts 3-phase Wye system. This results in 208 volts AC between lines (nominal) and will therefore draw less current for the same output power compared to operating the loudspeaker from 120 volts AC (line- neutral). Make sure that the voltage remains within the recommend operating window. The ground terminal must always be used for safety and the line-to-ground voltage should never exceed 250 volts AC (typically there will be 120 volts AC from line to ground in the above example).

Power Connector Wiring

The M2D and M2D-Sub loudspeakers require a grounded outlet. It is very important that the system be properly grounded in order to operate safely and properly.

If your M2D or M2D-Sub loudspeaker is fitted with the VEAM multipin connector, see the Meyer Sound document VEAM Cable Wiring Reference (part number 06.033.113) for the wiring conventions and pin-outs for AC, audio, and RMS connections.

Meyer Sound offers two VIMs (VEAM interface module) for simple, all-in-one RMS, audio and power distribution using VEAM multi-conductor cables. As shown in Figure 1.5, the VIM-4 module consists of four VEAM connectors and 8-amp breakers for the M2D loudspeaker; the VIM-3 consists of three VEAM connectors and 10-amp breakers for the higher-current M2D-Sub loudspeaker. Both modules feature a single-phase IEC309 32-amp rear connector.

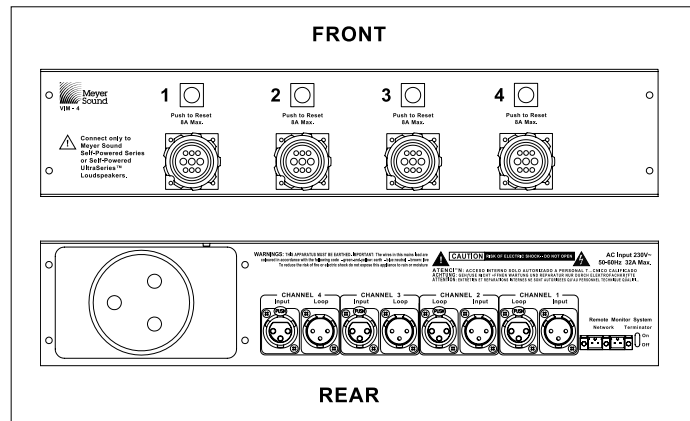
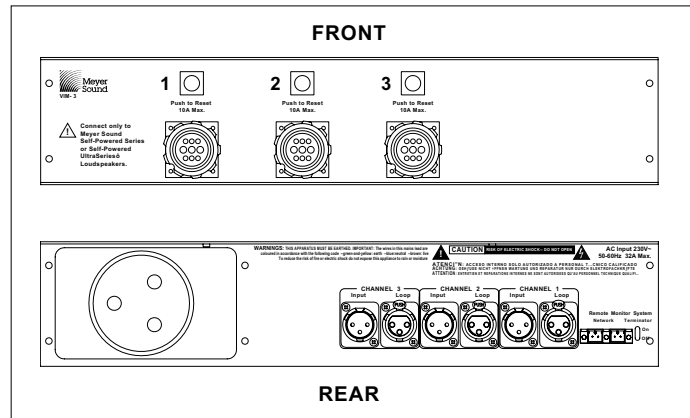

Figure 1.5. VIM-3 (top) and VIM-4 (bottom) modules

Use the AC cable wiring diagram below (Figure 1.6) to create international or special-purpose power connectors:

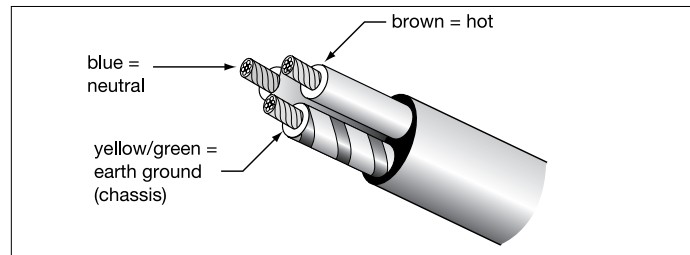

Figure 1.6. AC cable color code

If the colors referred to in the diagrams don't correspond to the terminals in your plug, use the following guidelines:

- Connect the blue wire to the terminal marked with an N or colored black.
- Connect the brown wire to the terminal marked with an L or colored red.
- Connect the green and yellow wire to the terminal marked with an E or colored green or green and yellow.

The M2D and M2D-Sub loudspeakers use different amplifiers to accommodate power requirements for their drivers, hence they have different voltage and current requirements. The M2D uses a UX-M2D amplifier while the M2D-Sub uses an HP-2/M2D-Sub amplifier.

VOLTAGE AND CURRENT REQUIREMENTS

M2D Voltage Requirements

The M2D loudspeaker operates safely and without audio discontinuity if the AC voltage stays within the operating window of 90 to 265 volts AC, at 50 to 60 Hz.

The M2D can withstand continuous voltages up to 265 Volts and allows any combination of voltage to GND (that is neutral-line-ground or line-line-ground).



CAUTION: Continuous voltages higher than 265 volts may damage your M2D.

After applying AC power, the system is muted while the circuitry charges up and stabilizes. During the next two seconds the following events occur:

1. The power supply fan turns on.
2. The main power supply slowly ramps on.
3. The green On/Temp LED on the User Panel lights up, indicating that the system is enabled and ready to pass audio signals.



CAUTION: If the On/Temp LED does not illuminate or the system does not respond to audio input after ten seconds, remove AC power immediately. Verify that the voltage is within the proper range. If the problem persists, please contact Meyer Sound or an authorized service center.

If voltage drops below the low boundary of its safe operating range (brownout), the M2D loudspeaker uses stored energy to continue functioning briefly, and shuts down only if voltage does not rise above the low boundary before storage circuits are depleted. How long the loudspeaker will continue to function during brownout depends on the amount of voltage drop and the audio source level during the drop.

If the voltage increases above the upper boundary, the unit may be damaged.



NOTE: It is recommended that the supply be operated in its rated voltage window at least a few volts away from the turn on/off points. This ensures that AC voltage variations from the service entry, or peak voltage drops due to cable runs, do not cause the amplifier to cycle on and off. It also keeps high voltage from damaging the power supply.

M2D Current Requirements

Each M2D loudspeaker requires approximately 3 A rms max at 115 volts AC for proper operation. This allows up to five M2D loudspeakers to be powered from one 15 A breaker.

The M2D loudspeaker presents a dynamic load to the AC mains, which causes the amount of current to fluctuate between quiet and loud operating levels. Since different cables and circuit breakers heat up at varying rates, it is essential to understand the types of current ratings and how they correspond to circuit breaker and cable specifications.

The *maximum long-term continuous current* is the maximum rms current during a period of at least ten seconds. It is used to calculate the temperature increase in cables, in order to select a cable size and gauge that conforms to electrical code standards. It is also used to select the rating for slow-reacting thermal breakers.

The *burst current* is the maximum rms current during a period of approximately one second, used to select the rating for most magnetic breakers and to calculate the peak voltage drop in long AC cables according to the formula:

$$V_{pk}(\text{drop}) = I_{pk} \times R(\text{cable total})$$

The *ultimate short-term peak current* is used to select the rating for fast-reacting magnetic breakers.

Use Table 1.1 below as a guide when selecting cable gauge size and circuit breaker ratings for your operating voltage.

Table 1.1: M2D Current Ratings

Current Draw	115 V AC	230 V AC	100 V AC
Max. long-term continuous	3.1 A rms	1.6 A rms	3.6 A rms
Burst current	3.2 A rms	1.6 A rms	3.7 A rms
Ultimate short-term peak	5.8 A pk	2.9 A pk	6.7 A pk
Idle current	0.35 A rms	0.35 A rms	0.35 A rms



NOTE: For best performance, the AC cable voltage drop should not exceed 10 volts, or 10 percent at 115 volts and 5 percent at 230 volts. Make sure that even with the AC voltage drop the AC voltage always stays in the operating windows.

The minimum electrical service amperage required by an M2D system is the sum of each loudspeaker's maximum continuous rms current. An additional 30 percent above the minimum amperage is recommended to prevent peak voltage drops at the service entry.

M2D-Sub Voltage Requirements

The M2D-Sub loudspeaker operates safely and without audio discontinuity if the AC voltage stays within either of two operating windows at 50 or 60 Hz:

- 85 to 134 volts
- 165 to 264 volts



CAUTION: Continuous voltages higher than 264 volts can damage the unit.

After applying AC power, the proper operating voltage is automatically selected, but the system is muted. During the next three seconds the following events occur:

1. The primary fan turns on.
2. The main power supply slowly ramps on.
3. The green Active LED on the User Panel lights up, indicating that the system is enabled and ready to pass audio signals.



CAUTION: If the Active LED does not illuminate or the system does not respond to audio input after ten seconds, remove AC power immediately. Verify that the voltage is within the proper range. If the problem persists, please contact Meyer Sound or an authorized service center.

If voltage drops below the low boundary of either safe operating range (brownout), the M2D-Sub loudspeaker uses stored energy to continue functioning briefly, and shuts down only if voltage does not rise above the low boundary before the M2D-Sub loudspeaker's storage circuits are depleted. How long the loudspeaker will continue to function during brownout depends on the amount of voltage drop and the audio source level during the drop.

If the voltage increases above the upper boundary of either range, the power supply rapidly turns off, preventing damage to the unit.



NOTE: If voltage fluctuates within either operating range, automatic tap selection stabilizes the internal operating voltage. This tap selection is instantaneous, and there are no audible artifacts.

If the M2D-Sub loudspeaker shuts down due to either low or high voltage, its power supply automatically turns on after three seconds if the voltage has returned to either normal operating window. If the M2D-Sub does not turn back on after ten seconds, remove AC power immediately (see previous Caution).



NOTE: It is recommended that the supply be operated in the rated voltage windows at least a few volts away from the turn on/off points. This ensures that that AC voltage variations from the service entry – or peak voltage drops due to cable runs – do not cause the amplifier to cycle on and off.

M2D-Sub Current Requirements

The M2D-Sub loudspeaker presents a dynamic load to the AC mains, which causes the amount of current to fluctuate between quiet and loud operating levels. Since different cables and circuit breakers heat up at varying rates, it is essential to understand the types of current ratings and how they correspond to circuit breaker and cable specifications.

The *maximum long-term continuous current* is the maximum rms current during a period of at least ten seconds. It is used to calculate the temperature increase in cables, in order to select a cable size and gauge that conforms to electrical code standards. It is also used to select the rating for slow-reacting thermal breakers.

The *burst current* is the maximum rms current during a period of approximately one second, used to select the rating for most magnetic breakers and to calculate the peak voltage drop in long AC cables according to the formula:

$$V_{pk}(\text{drop}) = I_{pk} \times R(\text{cable total})$$

The *ultimate short-term peak current* is used to select the rating for fast-reacting magnetic breakers.

Use Table 1.2 below as a guide when selecting cable gauge size and circuit breaker ratings for your operating voltage.

Table 1.2. M2D-Sub Current Ratings

Current Draw	115 V AC	230 V AC	100 V AC
Max. long-term continuous	8.8 A rms	4.4 A rms	10 A rms
Burst current	19 A rms	9.5 A rms	22 A rms
Ultimate short-term peak	39 A pk	20 A pk	45 A pk
Idle current	1.2 A rms	0.6 A rms	1.3 A rms



NOTE: For best performance, the AC cable voltage drop should not exceed 10 volts, or 10 percent at 115 volts and 5 percent at 230 volts. Make sure that even with the AC voltage drop the AC voltage always stays in the operating windows.

The minimum electrical service amperage required by the M2D-Sub system is the sum of each loudspeaker's maximum continuous rms current. An additional 30 percent above the minimum amperage is recommended to prevent peak voltage drops at the service entry.



CAUTION: In the unlikely event that the circuit breakers trip (the white center buttons pop out), disconnect the AC power cable. Do not reset the breakers with the AC connected. Contact Meyer Sound for repair information.



CAUTION: The M2D and M2-Sub loudspeakers require a ground connection. Always use a grounded outlet and plug.

CHAPTER 2: AMPLIFICATION AND AUDIO

The M2D and M2D-Sub loudspeakers use sophisticated amplification and protection circuitry to produce consistent and predictable results in any system design. This chapter will help you understand and harness the power of the M2D and M2D-Sub amplifier and audio systems.

The rear panels of the M2D and M2D-Sub loudspeakers (Figures 2.1 and 2.2) provide AC connection, audio input, loop out and an interface to the RMS communications module.

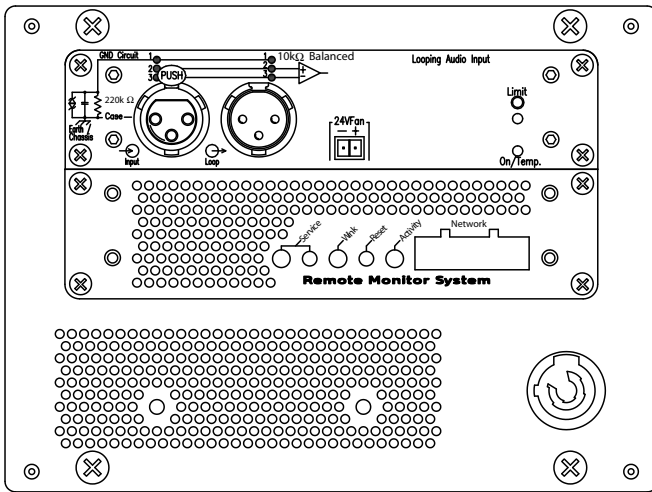

Figure 2.1. The user panel of the M2D loudspeaker

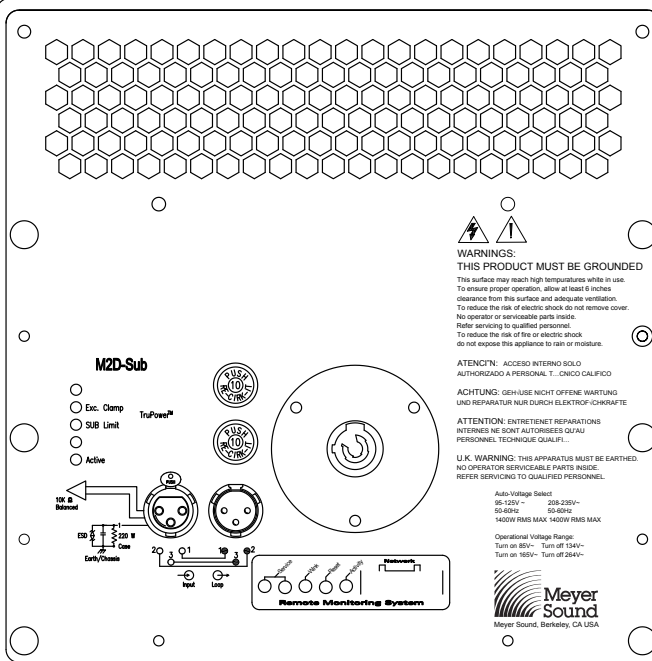

Figure 2.2. The user panel of the M2D-Sub loudspeaker

AUDIO INPUT

The M2D and M2D-Sub loudspeakers present a 10 kOhm balanced input impedance to a three-pin XLR connector with the following connectors:

- Pin 1 — 220 kOhm to chassis and earth ground (ESD clamped)
- Pin 2 — Signal (+)
- Pin 3 — Signal (-)
- Case — Earth (AC) ground and chassis

Pins 2 and 3 carry the input as a differential signal; pin 2 is hot relative to pin 3, resulting in a positive pressure wave when a positive signal is applied to pin 2. Pin 1 is connected to earth through a 220 kOhm, 1000 pF, 15 V clamp network. This ingenious circuit provides virtual ground lift for audio frequencies, while allowing unwanted signals to bleed to ground.

Use standard audio cables with XLR connectors for balanced signal sources. Make sure that pin 1 (shield) is always connected on both ends of the cable. Telescoping grounding schemes are not recommended.

CAUTION: Ensure that all cabling carrying signals to M2D or M2D-Sub loudspeakers in an array is wired correctly: Pin 1 to Pin 1, Pin 2 to Pin 2, and so forth, to prevent the polarity from being reversed. Any number of loudspeakers — even one in the array — with reversed polarity will result in severe degradation in frequency response and coverage.

Audio signals can be daisy-chained using the loop output connector on the user panel (Figure 2.3). A single source can drive multiple M2D or M2D-Sub loudspeakers with a paralleled input loop, creating an unbuffered hard-wired loop connection.

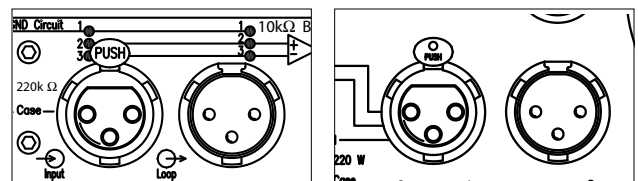

Figure 2.3. M2D and M2D-Sub user panel audio input connectors

When driving multiple loudspeakers in an array, make certain that the source device can drive the total load impedance presented by the paralleled input circuit of the array. The audio source must be capable of producing a minimum of 20 dB volts (10 volts rms into 600 ohms) in order to produce the maximum peak SPL over the operating bandwidth of the loudspeaker.

To avoid distortion from the source, make sure the source equipment provides an adequate drive circuit design for the total paralleled load impedance presented by the array. The input impedance for a single loudspeaker is 10 kOhms: if n represents the number of M2D/M2D-Sub loudspeakers in an array, paralleling the inputs of n loudspeakers will produce a balanced input load of 10 kOhms divided by n .



NOTE: Most source equipment is safe for driving loads no smaller than 10 times the source's output impedance.

For example, cascading an array of 10 units consisting of M2D and/or M2D-Sub loudspeakers produces an input impedance of 1000 ohms (10 kOhms divided by 10). The source equipment should have an output impedance of 100 ohms or less. This is also true when connecting M2D/M2D-Subs in parallel (loop out) with other self-powered Meyer Sound loudspeakers.



CAUTION: Shorting an input connector pin to the case can form a ground loop and cause hum.



TIP: If abnormal noises such as hiss and popping are produced by the loudspeaker, disconnect the audio cable from the loudspeaker. If the noise stops, then most likely the problem is not with the loudspeaker. Check the audio cable, source, and AC power for the source of the problem.

M2D INTERCONNECTIONS

For the low and low-mid frequencies, the M2D utilizes two 4-ohm, 10-inch cone drivers featuring lightweight neodymium magnet structures.

A complex passive network connected between the amplifier and the drivers is used to ensure smooth response in the critical midrange. At the lowest frequencies, the two high-power, back-vented cone drivers combine to reproduce coherent low frequencies. In the mid frequencies, the passive network feeds only

one of the two drivers while correcting the phase shift at low frequencies for proper addition with the other driver. This technique eliminates interference between the high-frequency and low-frequency drivers that would otherwise occur near the crossover frequency, and maintains optimal polar and frequency response characteristics.

To reproduce high frequencies, the M2D employs Meyer Sound's patented REM ribbon emulation manifold to couple a constant-directivity horn to a compression driver with a 1.5-inch exit (4-inch diaphragm). REM controls the output of the driver and introduces it to the horn throat within a three-inch path length, dramatically minimizing distortion. This unique horn design produces a coherent wave front that is characteristic of, but much more powerful than, a large ribbon driver.



CAUTION: All Meyer Sound loudspeakers are shipped with the drivers in correct alignment. However, if a driver needs to be replaced, make sure the replacement is reinstalled with the correct polarity. Incorrect driver polarity impairs the system performance and may damage the drivers.

M2D AMPLIFICATION

All three drivers in the M2D are powered by a two-channel proprietary Meyer Sound UX-M2D amplifier utilizing complementary MOSFET output stages (class AB/bridged) capable of delivering 700 watts total. The amplifier employs electronic crossover, phase, and frequency response correction filters – as well as protection circuitry – to process the audio signal. All the specific functions for the M2D are determined by the control card installed inside the amplifier; one channel of the amplifier drives the low and low-mid section of the M2D through the passive network while the other channel drives the high frequency section.

M2D LIMITING

Each channel of the amplifier has limiters that prevent driver over-exursion and regulate the temperature of the voice coil. Limiter activity for the high and low channels is indicated by two yellow Limit LEDs on the rear panel (the high-frequency limit LED is the top and the low-frequency limit LED is the bottom, as shown in Figure 2.4).

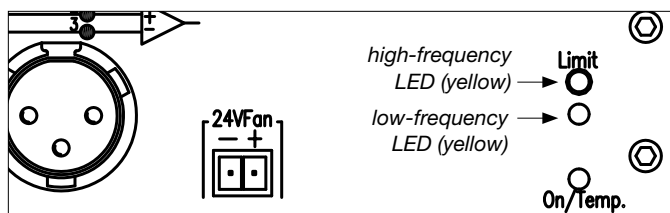

Figure 2.4. The M2D loudspeaker's limit LED indicators

If the limit LEDs are on for no longer than two seconds, and off for at least one second, the M2D loudspeaker is performing within its acoustical specifications and operating at a normal temperature. If either LED remains on for longer than three seconds, this indicates that the particular channel is incurring hard limiting that can result in the following negative consequences:

- Increasing the input level will not increase the volume.
- The system distorts due to clipping and nonlinear driver operation.
- Unequal limiting between the low and high frequency drivers can alter the frequency response.
- The lifespan of the drivers is reduced because they are subjected to excessive heat.

While the limiters protect the system under overload conditions and exhibit smooth sonic characteristics, it is recommended that you do not drive the M2D into continuous limiting.



NOTE: The limit LEDs indicate when the safe power level is exceeded. If an entire system of M2Ds begins to limit before reaching the required SPL, you should consider adding more loudspeakers to the array.

The limiters cease operation when the level in the channel returns to normal. Limiters have no effect on the signal when the LED is inactive.

M2D AMPLIFIER COOLING SYSTEM

The M2D loudspeaker employs a natural convection cooling system. A large aluminum heatsink is cooled by the air flowing over its fins.

If the temperature of the heatsink reaches 85°C (185°F), the On/Temp LED on the rear panel turns from green (On) to red (Temp) and the limiter threshold is lowered to a safe level to prevent the system from overheating. Under high temperature conditions the maximum output level is reduced 6 dB. When the heatsink temperature decreases to 75°C (167°F), the On/Temp LED changes from red to green and the limiter threshold returns to normal.

Optional Fan Assembly Kit

While convection cooling is adequate for most applications, in situations where the M2D loudspeaker is driven into continuous limiting under severe temperature conditions, or where ventilation is restricted, installation of an optional fan kit is recommended to maintain a safe operating temperature.

The easy-to-install fan, powered through the 24 V fan connector on the M2D loudspeaker's user panel, blows air directly onto the heatsink. The fan speed increases as the heatsink temperature rises, which maintains a safe operating temperature with minimal fan noise. Contact Meyer Sound to order the fan kit.

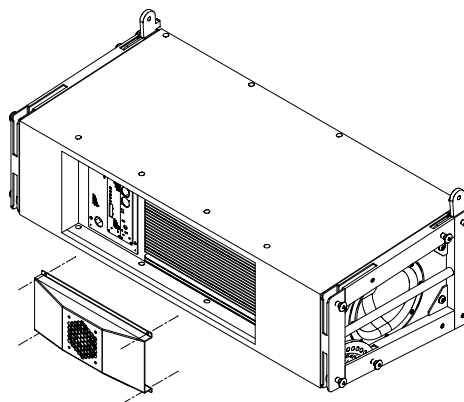

Power Supply Fan

The power supply is cooled by a single small internal fan. The fan operates on low speed when the unit is first powered up. The fan increases speed as the system is driven with audio. Since the fan draws air in from and exhausts through the back of the cabinet, there must be at least 6 inches of clearance behind the cabinet to allow an adequate air flow.

M2D-SUB INTERCONNECTIONS

The M2D-Sub loudspeaker utilizes two 4-ohm, 15-inch cone drivers. These drivers feature lightweight neodymium magnet structures. Each channel of the amplifier drives one low frequency driver.



CAUTION: All Meyer Sound loudspeakers are shipped with the drivers in correct alignment. However, if a driver needs to be replaced, make sure the replacement is reinstalled with the correct polarity. Incorrect driver polarity impairs the system performance and may damage the drivers.

M2D-SUB AMPLIFICATION

The M2D-Sub loudspeaker is powered by the Meyer Sound HP-2/M2D-Sub amplifier, a high-power two-channel amplifier. The amplifier utilizes complementary MOSFET output stages (class AB/H) capable of delivering 2250 watts total. All the specific functions for the M2D-Sub loudspeaker such as crossover points, frequency and phase response, and driver protection are determined by the control card installed inside the amplifier.

M2D-SUB LIMITING

The M2D-Sub loudspeaker uses Meyer Sound's advanced TruPower limiting system.

Conventional limiters assume a constant loudspeaker impedance and therefore set the limiting threshold by measuring voltage only. However, this method is inaccurate, because the driver's impedance changes in response to the frequency content of the source material and thermal variations in the driver's voice coil and magnet. Consequently, conventional limiters begin limiting prematurely, which under-utilizes system headroom and lessens the driver's dynamic range.

In contrast, TruPower limiting accounts for varying driver impedance by measuring current, in addition to voltage, to compute the actual power dissipation in the voice coil. TruPower limiting improves performance before and during limiting by allowing each driver to produce maximum SPL across its entire frequency range. In addition, TruPower limiting eliminates power compression when the system is operated at high levels for extended periods, and also extends the driver life cycle by controlling voice coil temperatures.

The actual power is monitored for each of the two amplifier channels. When the safe continuous power level is exceeded in any channel, the TruPower limiter controlling both amplifier channels engages. Limiting activity is indicated by the Sub Limit LED on the user panel (Figure 2.5).

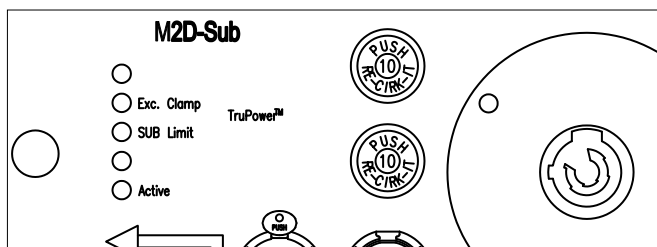

Figure 2.5. The M2D-Sub's LED indicators

The M2D-Sub loudspeaker performs within its acoustical specifications and operates at a normal temperature if the Sub Limit LED is lit for no longer than two seconds, and

then go off for at least one second. If the LED remains on for longer than three seconds, this indicates that the amplifier is incurring hard limiting that can result in the following negative consequences:

- Increasing the input level will not increase the volume.
- The system distorts due to clipping and nonlinear driver operation.
- The lifespan of the drivers is reduced because they are subjected to excessive heat

Each low-frequency driver is driven by a separate amplifier channel but is routed to one limiter; the Sub Limit LED on the user panel indicates TruPower limiting activity for the drivers. The Sub Limit LED indicates when the safe power level is exceeded (Figure 2.5).



CAUTION: While the limiters protect the system under overload conditions and exhibit smooth sonic characteristics; we recommend that you do not drive the M2D-Sub loudspeaker into continuous limiting. If an entire system of M2D-Sub loudspeakers begins to limit before reaching the required sound pressure level, you should consider adding more M2D-Sub loudspeakers to the system.

M2D-Sub Excursion Clamp

The drivers in the M2D-Sub are protected by an excursion clamping circuit that provides instantaneous braking for the drivers without the pumping effects commonly produced by compressor/limiters.

The circuit uses sophisticated filters to minimize the distortion normally caused by clamping and clipping. As the M2D-Sub's input signal is increased past the clamping point at each frequency, the output signal remains at a fixed level for that frequency, protecting the drivers and minimizing negative sonic effects. The Exc.Clamp LED, shown in Figure 2.5, illuminates when the maximum allowed peak voltage at each frequency is reached. This circuit works for all frequencies, not just very low frequencies where the drivers are more vulnerable to overexcursion.

The limiters cease operation when the power level in the channel returns to normal. Limiters have no effect on the signal when the LED is inactive

M2D-SUB AMPLIFIER COOLING SYSTEM

The M2D-Sub loudspeaker uses a forced-air cooling system with two fans to prevent the amplifier module from overheating. The fans draw air in through ducts on the front of the cabinet, over the heatsink, and out the rear of the cabinet (Figure 2.6). Because dust does not accumulate in the amplifier circuitry, its lifespan is increased significantly. The front grille helps to filter the air and should always be in place during operation.

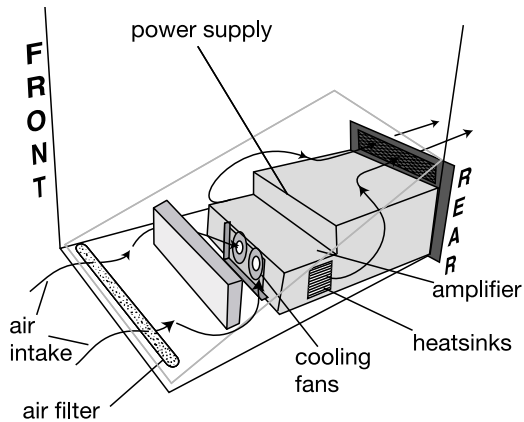

Figure 2.6. Airflow through the M2D-Sub



CAUTION: When operating a weather-protected M2D-Sub loudspeaker always be sure the rain hood is fully open. Leaving the hood closed or partially open will limit the airflow through the amplifier, which could cause it to overheat and shut down.

The variable-speed primary fan runs continuously and is inaudible at its slowest speed. The primary fan's speed increases when the heatsink reaches 42° C (108° F). The fan reaches full speed at 62° C (144° F) and is still barely audible near the cabinet, even without an audio signal. In the event that the heatsink temperature reaches 74° C (165° F), the secondary fan turns on and is clearly audible without an audio signal. The secondary fan turns on in response to:

- Primary fan failure (check status immediately)
- Very high signal levels over a prolonged period
- Accumulation of dust along the cooling path

The secondary fan turns off when the temperature decreases to 68° C (154° F).



NOTE: In the highly unlikely event that the secondary fan does not keep the temperature below 85° C (185° F), the M2D-Sub automatically shuts down until AC power is removed and reapplied. If the M2D-Sub shuts down again after cooling and reapplying AC power, contact Meyer Sound for repair information.

Despite the M2D-Sub loudspeaker's filtering, extensive use or a dusty operating environment can allow dust to accumulate along the path of the airflow, preventing normal cooling. To prevent this, you should periodically remove the grille frame and amplifier module and use compressed air to clear dust from the grille, fans, and heatsinks. Make sure that the air ducts are clear.



CAUTION: Be sure to unplug power to the unit before cleaning the amplifier.

CHAPTER 3: RMS REMOTE MONITORING SYSTEM

The M2D and M2D-Sub loudspeakers are fitted standard with an RMS communication module installed in the rear of the loudspeaker. The RMS real-time networked monitoring system connects Meyer Sound self-powered loudspeakers with a Windows-based PC at the sound mix position or other remote location. Optional RMS software delivers extensive status and system performance data directly to you from every installed loudspeaker.

RMS allows you to monitor amplifier voltages, limiting activity, power output, temperature, fan and driver status, warning alerts, and other key data; data is updated two to five times per second.

 **NOTE:** Optional Speaker Mute and Solo functions, helpful for acoustic setup or troubleshooting, are also available. An internal jumper must be installed in the RMS communication module in order to enable Mute and/or Solo functionality; the software also needs to be enabled for these functions.

The M2D and M2D-Sub loudspeakers are shipped with these functions disabled. Once enabled, the jumper(s) can still be removed to eliminate any chance of an operator error (a muting error, for example) during a performance, and both functions can be controlled by software commands in any case. Also note that RMS does not control loudspeaker volume or AC power.

Loudspeakers are identified on the network by Node Names assigned during a one-time “commission” (Figure 3.1) into the RMS database that resides on your computer (as a part of the software).

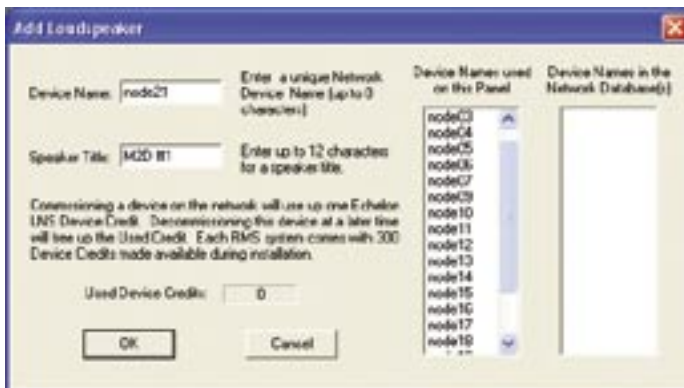

Figure 3.1. Commissioning a loudspeaker using RMS

This information is permanently retained on each RMS communication module and in the RMS database unless you modify it. Speaker Titles can be modified at any time, allowing you to customize how you view the data. In addition, any M2D or M2D-Sub loudspeaker can be physically identified from RMS software by activating the Wink function – a Wink LED will illuminate the RMS communication module that corresponds to its Node Name.

M2D and M2D-Sub loudspeakers are identified using the RMS software by activating the “service” function; an icon will show up on the RMS screen corresponding to its Node Name (Figure 3.2). This makes verifying Speaker Titles and speaker field labels easy, using the Wink or Service Button commands.

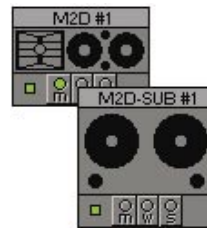

Figure 3.2. RMS loudspeaker icons

UNDERSTANDING THE RMS USER PANEL

The RMS section of the user panel has three LEDs and two buttons (Figure 3.3).

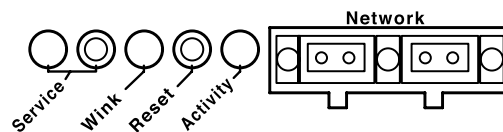



Figure 3.3. RMS section of the user panel

The following sections describe their functions.

Service LED (Red)

When blinking once every two seconds, the Service LED indicates that the network hardware is operational, but the loudspeaker is not installed (commissioned) on the network. When a loudspeaker has been installed on the network the Service LED will be unlit and the Activity LED will flash continuously.

 **NOTE:** When continuously lit, the Service LED indicates that the loudspeaker has had a local RMS hardware failure. In this case, the RMS communication module may be damaged and you should contact Meyer Sound Technical support.

Service Button

Pressing the Service button will display an icon on the corresponding loudspeaker display icon on the RMS screen. When used in combination with the Reset button, the communications module will be decommissioned from the network and the red Service LED will blink.

Wink LED (green)

When lit, the Wink LED indicates that an ID signal has been sent from the host station computer to the loudspeaker. This is accomplished using the Wink button on the loudspeaker Icon, Meter or Text views in the RMS monitoring program.

Reset Button

Pressing the Reset button will cause the firmware code within the RMS card to reboot. However, the commissioning state of the communications module will not change (this is stored in flash memory). When used in combination with the Service button, the communications module will be decommissioned from the network and the red Service LED will blink.

Activity LED (Green)

When the loudspeaker has been commissioned the Activity LED will flash continuously. When the Activity LED is unlit the loudspeaker has not been installed on the network.



NOTE: The LEDs and buttons on the RMS section of the user panel shown in Figure 3.3 are used exclusively by RMS, and have no effect on the acoustical and/or electrical activity of the M2D/M2D-Sub loudspeaker itself – unless Mute or Solo is enabled at the module and from the RMS software.

USER INTERFACE

The optional RMS software features an intuitive, graphical user interface. As mentioned earlier, each loudspeaker appears on your computer monitor as a “view” in the form of a status icon, bar graph meter, or text meter (numerical values), depending on your preferences.

Each view contains loudspeaker identification information and data from the amplifier, controller, drivers and power supply of that particular unit. System status conditions cause changes in icon and bar graph indicators, alerting the operator to faults or excessive levels. The views are moveable and are typically arranged on the screen to reflect the physical layout of the loudspeakers. You can design a screen “panel” of icons or meters, as shown in Figure 3.4, and save it on your hard disk, with the panel conveniently named for a unique arrangement or performer.

If the loudspeaker installation pattern changes completely, a new screen panel can be built. If a different subset of already installed loudspeakers will be used for a subsequent show, only selected loudspeakers need to appear on the monitoring screen for that performance.

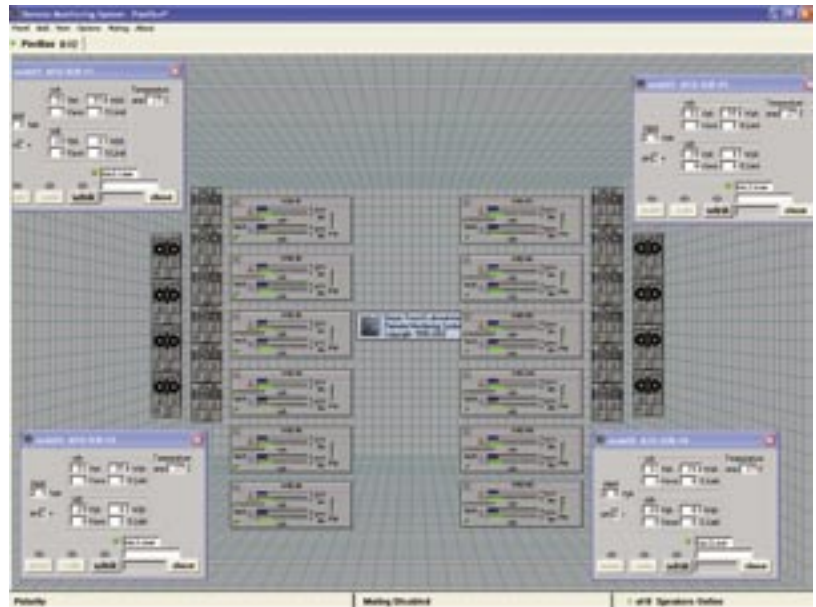

Figure 3.4. Sample RMS display panel



NOTE: For more information on RMS, please refer to the RMS User Guide included with the software.

CHAPTER 4: LINE ARRAYS AND SYSTEM INTEGRATION

A line array, in the most basic sense, is a group of closely spaced loudspeakers arrayed in a straight line, operating with equal amplitude and in phase. Although line arrays have been used since the 1950s, line array systems that provide full bandwidth directivity are relatively new to the sound reinforcement industry.

HOW LINE ARRAYS WORK

Line arrays achieve directivity through constructive and destructive interference. For example, consider one loudspeaker with a single 12-inch cone radiator in an enclosure. We know from experience that this loudspeaker's directivity varies with frequency: at low frequencies it is omnidirectional; as the frequency increases (wavelength grows shorter), directivity narrows. Above about 2 kHz, it becomes too beamy for most applications, which is why practical system designs employ crossovers and multiple elements to achieve directivity across the audio band.

Stacking two of these loudspeakers one atop the other and driving both with the same signal results in a different radiation pattern. At common points on-axis, there is constructive interference, and sound pressure increases by 6 dB relative to a single unit. At other points off-axis, path length differences produce cancellation, resulting in a lower sound pressure level. In fact, if you drive both units with a sine wave, there will be points where the cancellation is complete, which can be shown in an anechoic chamber. This is destructive interference, sometimes referred to as combing.

A typical line array comprises a line of loudspeakers carefully spaced so that constructive interference occurs on-axis of the array, and destructive interference (combing) is aimed to the sides. While combing has traditionally been considered undesirable, line arrays use combing to positive effect: Without combing, there would be no directivity.

THE M2D LINE ARRAY

The M2D loudspeaker employs a unique combination of drivers to enable you to optimize both coverage and directivity in an M2D system. To achieve optimal results, it's critical to understand how these components work together.

High Frequencies

For high frequencies, the M2D loudspeaker provides a consistent beamwidth of coverage in both the vertical and horizontal planes. In the horizontal pattern of the array, the M2D loudspeaker's horn works just as any wave guide does to produce wide coverage; in the vertical, however, the

M2D loudspeaker's REM technology provides very narrow coverage in order to:

- Minimize destructive interference between adjacent elements
- Maximize coupling to throw longer distances

As more and more elements are arrayed in a vertical column, they throw mid- and high-frequency energy more effectively through coupling. The amount of energy can then be controlled using the relative splay between the elements. Gently curving a line array (no more than 7 degrees of splay between cabinets) can aid in covering a broader vertical area, while narrow angles provide a longer throw and coverage that more closely matches that of the low frequencies.



NOTE: Radically curving a line array introduces problems. While a drastic angle can spread high frequencies over a larger area, low frequencies remain directional (the curvature change is trivial at long wavelengths), resulting in uneven coverage. In addition, a vertically narrow high-frequency pattern combined with large angles can produce hot spots and areas of poor high-frequency coverage.

Mid to Low Frequencies

For the mid to low frequencies, array elements must be coupled together to narrow their vertical coverage and throw mid and low energy to the far field. As frequencies get lower and wavelengths get longer, the splay angle between cabinets has little effect. The number of array elements, however, is important: the more M2D loudspeakers used, the narrower the vertical beamwidth becomes.

Adjusting Line Array Coverage

Regardless of the needs of your system design, fine-tuning coverage for a single M2D array will be dependent on three factors:

- **Number of Array Elements.** Determining the number of elements to use is critical: Too few elements can drastically affect the uniformity of coverage of both SPL and frequency.
- **Vertical Splay Angles.** Changing the splay angles between array elements has a significant impact on vertical coverage, with the result that narrower vertical splay angles produce a higher Q vertical beamwidth, while wider splay lowers the Q at high frequencies.

- **Horizontal Coverage.** Horizontal coverage for a single array can be considered constant regardless of the number of array elements or the angles between them.



TIP: The angle between two or more line arrays can also be changed to meet additional design requirements (for example, wall reflections).

Given these factors, designing and deploying a line array system will typically have the following objectives:

- Even horizontal and vertical coverage
- Uniform SPL
- Uniform frequency response
- Sufficient SPL for the application

With two different technologies (low-frequency line array and high-frequency wave guide) built into each M2D cabinet, achieving these goals becomes a multi-step process, with different strategies for the lower and higher frequencies for long throws and short throws.



NOTE: THE Meyer Sound MAPP Online prediction program, covered in greater detail later in Chapter 5, “System Design and Integration Tools,” enables you to make accurate and comprehensive predictions for optimal coverage(s) during the design phase.

High-Frequency Design Strategies

Planning for high-frequency coverage is a matter of fine-tuning the splay angles between cabinets while keeping an eye on the number of far-throwing elements in the array. The number of elements does not necessarily have a significant impact on SPL at high frequencies (it will at low frequencies), but can profoundly affect throw.

For the far field, a smaller mechanical splay angle achieves superior throw through better coupling to compensate for energy lost over distance. In the near- to mid-field, larger splay angles increase vertical coverage.

Low-Frequency Design Strategies

While the wave guide provides isolated control over various mid to high-frequency coverage areas, the low-frequency section of an M2D line array still requires mutual coupling — with equal amplitude and phase — to achieve better directionality.

Low frequency directionality is less dependant on the array's relative splay angles and more dependent on the number of elements of the array. At low frequencies, the more elements in the array, the more directional the array becomes.

Electronically Driving the Array

Once the design (number of elements, vertical splay angles and horizontal splay angles between arrays) has been determined, you can effectively optimize the array by driving it with multiple equalization channels, or zones. Typically arrays are divided in two or three zones depending on the design and size of the array; to optimize EQ, different strategies are used for the low and high frequencies for long throws and short throws.

High-Frequency Equalization Strategies

For the far field, air absorption plays a critical role. The farther the distance, the greater the attenuation at high frequencies. In this zone, very high frequencies generally need a boost to compensate for energy lost over distance; the gain needed is usually proportional to the distance and high-frequency air absorption.

In the near- to mid-field, the air absorption is not nearly as critical; in this zone, high frequencies need little or no additional gain.



TIP: If your M2D array uses a third zone for short throws, high frequencies there may need to be attenuated to avoid excess levels in the near field.

Low-Frequency Strategies

Although the array can (and usually should) be zoned for implementing different equalization curves for high frequencies, similar or identical equalization should be maintained in all the low-frequency filters. Different low-frequency equalization settings in the same array will degrade the desired coupling effect.

For the same reason, gain tapering is not recommended for line arrays, since adjusting various zones with an overall amplitude control for each zone results in the following:

1. Directionality decreases.
2. Low-frequency headroom decreases.
3. The length of the line array column is effectively shortened.



TIP: The LD-3 compensating line driver was designed to implement both low- and high-frequency strategies with its array and atmospheric correction functions. The LD-3 line driver's array correction function compensates for low-frequency build-up, while the atmospheric controls correct for the attenuation of sound in air at high-frequencies. For more information on the LD-3 line driver's atmospheric and array correction features, please refer to the LD-3 datasheet, operating instructions or visit www.meyersound.com.

Figure 4.1 shows a series of MAPP Online predictions based on an example M2D system design. In this case, small vertical splay angles on the upper part of the array are used to cover longer distances, while greater angles are used in the lower elements to increase vertical coverage for shorter distances.

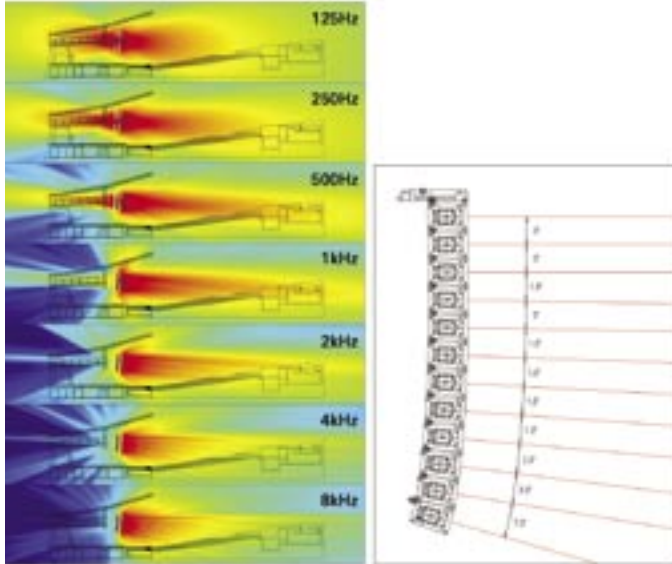

Figure 4.1: Using vertical splay to adjust a line array's coverage

The block diagram (Figure 4.2) shows one method of driving this example array, along with additional fill loudspeakers and subwoofers (not in the MAPP Online predictions). Equalizers for each zone, as well as digital delays, provide a time adjustment to compensate for the various sub-systems if they are geometrically out of plane.

CAUTION: This example is not meant to be used as a template for your own system designs. Acoustical characteristics, physical constraints, audio content, audience, and a slew of other factors should always be uniquely weighed into your own applications on a per-project basis.

USING THE M2D-SUB WITH THE M2D

The M2D provides full bandwidth frequency response down to 60 Hz, however, if the application or the program content requires additional low-frequency energy (e.g., clubs, discos, reinforcement of popular music), the M2D-Sub is naturally the best way to augment your M2D system. The M2D-Sub can achieve frequency response down to 30 Hz, extending system response appreciably and increasing the acoustic power of a system in the lowest frequencies.

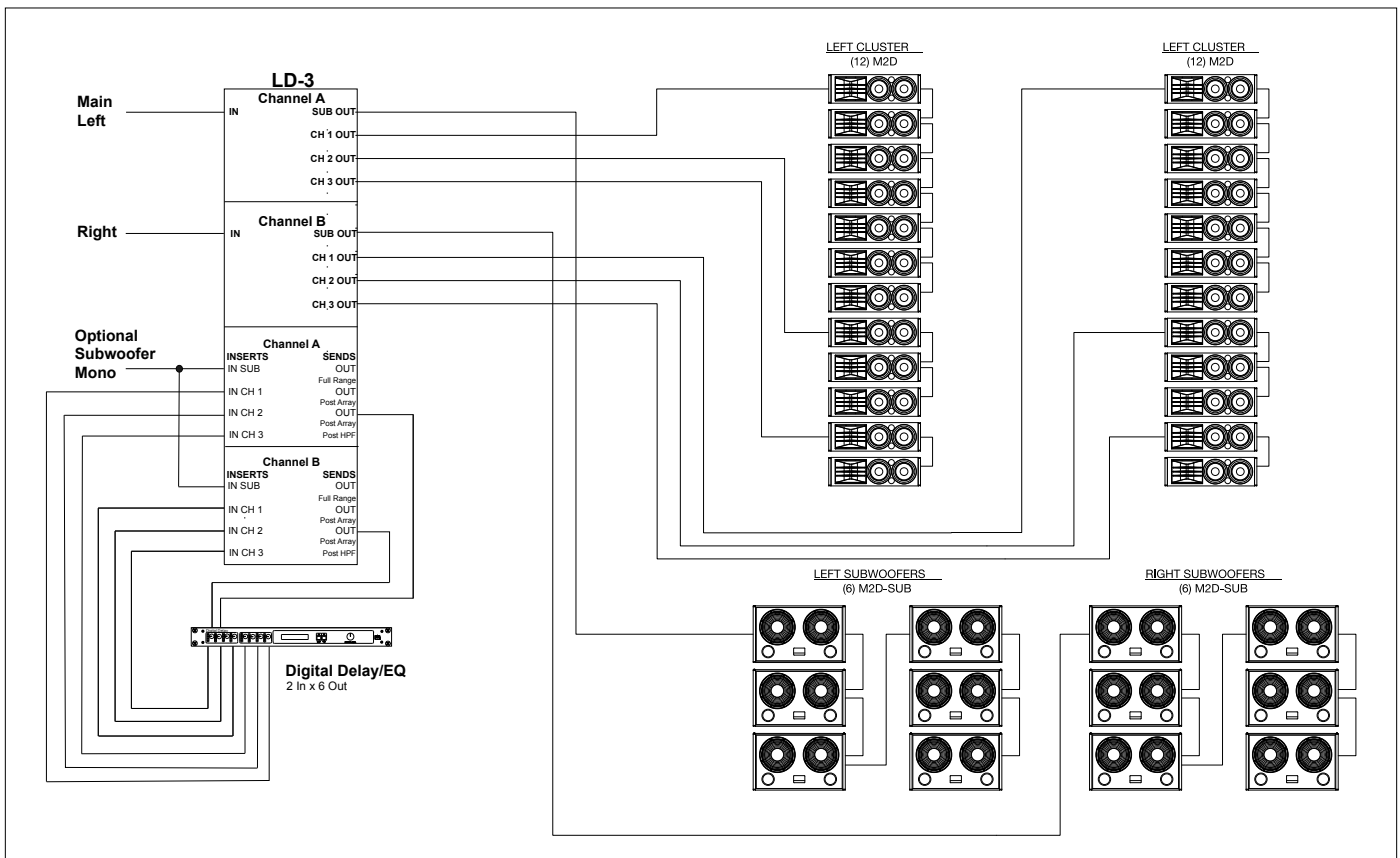

Figure 4.2: Sample block diagram of M2D/M2D-Sub array

In addition, the use of high-pass filters to drive an M2D system with the M2D-Sub flattens overall frequency response and slightly increases M2D headroom in the lowest end of its usable spectrum.

The ideal ratio of M2D to M2D-Sub loudspeakers depends on the configuration of the system, the application, and the frequency content of the signal being reproduced. For most applications, two M2Ds for each M2D-Sub yields good results in frequency response and headroom.



NOTE: The M2D-Sub limit LEDs indicate when its safe power level is exceeded. If the M2D-Sub loudspeakers used in a system begin to limit before reaching the required SPL at low frequencies, you may need to add more M2D-Subs to satisfy the SPL requirements without exposing the drivers to excessive heat and/or excursion.

The M2D and M2D-Sub loudspeakers can accommodate three basic connection options.

Daisy-Chained

When M2Ds and M2D-Subs are daisy-chained using the loop feature on the user panel, the result will have a fairly flat frequency response. However, at a ratio of two M2D to each M2D-Sub loudspeaker, the response will have a rise in the 70 to 160 Hz range where the frequency of the M2D and M2D-Sub overlap.



CAUTION: Always ensure that the source equipment can drive the total load of the paralleled system.



NOTE: When both M2D and M2D-Sub loudspeakers are used in their full-range configuration (e.g., looped audio or the same audio feed), their polarities should be kept the same if they are co-planar or near each other. If they are separated by a greater distance – or delay must be used between them – a measurement system such as the SIM audio analyzer should be used to determine the correct delay and polarity.

Adding a Line Driver

Driving an M2D/M2D-Sub system with the same signal from different outputs using a line driver allows adjustments to the gain and polarity of each sub-system, and could be used effectively to compensate for the ratio of loudspeakers or

acoustical conditions. If the gains are adjusted to the same level, the combined response is identical to a daisy-chain configuration with a rise in level on the overlapping range. Meyer Sound makes available three different line drivers.

Engaging the Lo-Cut Filter

Using the LD-1A, LD-2 or LD-3 Lo-Cut filter (the 160 Hz HPF position on the LD-3) can produce an M2D/M2D-Sub system (in close proximity and co-planar) with very flat frequency response and a minimal area of overlap. The M2D loudspeakers in the system receive their signal following a high-pass filter, while the M2D-Subs apply their normal internal crossover frequencies to a full range signal.



NOTE: When driving M2Ds from the Mid-Hi output of the LD-1A, LD-2 or LD-3 line driver with the Lo-Cut filter engaged and M2D-Sub loudspeakers in their full-range configuration, their polarities should be kept the opposite if they are co-planar or near each other. This can be achieved by engaging the polarity reverse switch on the subwoofer output of the line driver. If your M2D and M2D-Sub loudspeakers are separated by a greater distance – or delay must be used between them – a measurement system such as the SIM audio analyzer should be used to determine the correct delay and polarity.



TIP: How flat the response will be is, in any case, dependent on proximity to boundary surfaces.

While the change of polarity with respect to a daisy-chained configuration is needed due to the phase shift caused by the high-pass filter at overlapping frequencies, placing M2D-Sub loudspeakers more than 4 feet apart from M2D loudspeakers may require reversing the polarities once again to compensate for the delay propagation.

Table 4.1: M2D and M2D-Sub frequency response results with LD-1A, LD-2 and LD-3 (160 Hz filter)

Lo-Cut	Reverse Switch	Result
Off	Off	Flat response (small rise on 70 Hz -160 Hz area)
Engaged	Engaged	Very flat response

Using the LD-3

In addition to the 160 Hz high-pass filter on the LD-3, the LD-3 compensating line driver provides additional filtering capabilities to help you further fine-tune an M2D/M2D-Sub system.

Table 4.2: M2D and M2D-Sub frequency response results with different filter configurations

HPF	LPF	o Reverse Switch	Result
Off	Off	Off	Flat response (small rise on 70 Hz -160 Hz area)
80	Off	Off	Very flat response, +3 dB sub gain recommended
80	80	Engaged	Very flat response, +3 dB sub gain recommended
160	OFF	Engaged	Very flat response



NOTE: For more information on the LD-3 line driver's atmospheric and array correction features, please refer to the LD-3 Operating Instructions or visit www.meyersound.com.

Digital Signal Processors

Full-range signals may be applied to Meyer Sound's self-powered loudspeakers because they have built-in active crossover circuits; external crossovers and digital signal processors (DSP) are optional and should be used very carefully due to phase shifts that can cause cancellations.

If a DSP is used, both M2D and M2D-Sub loudspeakers should be fed from the DSP in order to keep their delay time the same. Otherwise you may experience phase shift differences between the M2Ds and the M2D-Subs. In addition, you should verify the delay time between channels: Some DSPs may develop channel-to-channel delay errors when the DSP is near maximum throughput, which becomes more likely as the number of filters the DSP is using increases.

In no case should a filter higher than 2nd-order be used. The additional phase shift introduced by steep sloped filters deteriorates the impulse response and higher roll-off does not improve crossover interaction. In fact, it is highly recommended that the crossover/filter are set to emulate the low-cut LD-1A, LD-2 and LD-3 (at the 160 Hz position) characteristics themselves, as shown in Table 4.3.

Table 4.3: LD-1A, LD-2 and LD-3 (LD-3 at 160 Hz) "Lo-Cut Filter" Parameters

Type	Order	Pole Frequency	Q
High Pass	2 nd (-12 dB/oct)	162 Hz	0.82*

* If the DSP does not have variable Q for high-pass filters, the filter should be set to "Butterworth" (Q ≈ .7).

If the loudspeakers are going to be driven directly from DSP, verify that the outputs of the processor have the driving capabilities to drive the total load presented by the loudspeakers connected to it.



NOTE: When precise array design, subwoofer integration, DSP and delay systems, and compensation for acoustical conditions all come into play, measurement and correction tools are a must. Meyer's SIM audio analyzer and the CP-10 parametric equalizer are both highly recommended.

USING THE 650-P WITH THE M2D

In some applications – for instance, in a system design where the subwoofers do not need to be flown in the array – it may be desirable to deploy an M2D array in combination with Meyer Sound's 650-P high-power subwoofer. The 650-P subwoofer extends the M2D system frequency response down to 28 Hz, and can accommodate daisy-chain, line driver, and DSP connection options.



NOTE: The 650-P subwoofer does have a polarity switch, and you will need to ensure that it is set to pin 2 + (same polarity respect to the M2D loudspeaker's pin 2 +) when co-planar and in close-proximity to and M2D array.



NOTE: When driving M2Ds from the Mid-Hi output of the LD-1A, LD-2 or LD-3 line driver with the Lo-Cut filter engaged and 650-P subwoofer in their full-range configuration, their polarities should be kept the opposite if they are co-planar or near each other. If your M2D and 650-P loudspeakers are separated by a greater distance – or delay must be used between them – a measurement system such as SIM should be used to determine the correct delay and polarity.

Table 4.4: M2D and 650-P (650-P set to pin 2 positive) frequency response results with LD-1A, LD-2 and LD-3 (160 Hz filter)

Lo-Cut	⌀ Reverse Switch	Result
Off	Off	Flat response (small rise on 70 Hz -160 Hz area), -6 dB sub gain recommended*
Engaged	Engaged	Very flat response, -6 dB sub gain recommended*

* The 650-P subwoofer is +6 dB more sensitive than the M2D and M2D-Sub loudspeakers.

In addition to its 160 Hz high-pass filter, the LD-3 line driver provides additional filtering capabilities (Table 4.5) to help you further fine-tune an M2D and 650-P system.

Table 4.5: M2D and 650-P (650-P set to pin 2 positive) frequency response results with the LD-3 (using other filters)

HPF	LPF	⌀ Reverse Switch	Result
Off	55	Off	Flat response, -6 dB sub gain recommended*
80	80	Engaged	Very flat response, -6 dB sub gain recommended*
160	OFF	Engaged	Very flat response, -6 dB sub gain recommended*

* The 650-P subwoofer is +6 dB more sensitive than the M2D and M2D-Sub loudspeakers.

CHAPTER 5: SYSTEM DESIGN AND INTEGRATION TOOLS

Meyer Sound offers two comprehensive tools to assist you with the acoustical and functional requirements of system design and optimization. This chapter introduces you to the Meyer Sound MAPP Online acoustical prediction program, and the SIM audio analyzer, a robust instrumentation package for system measurement, analysis, and more.

MEYER SOUND MAPP ONLINE

The MAPP Online prediction program is a powerful, cross-platform, Java-based application for accurately predicting the coverage pattern, frequency response, impulse response, and maximum SPL output of single or arrayed Meyer Sound loudspeakers.

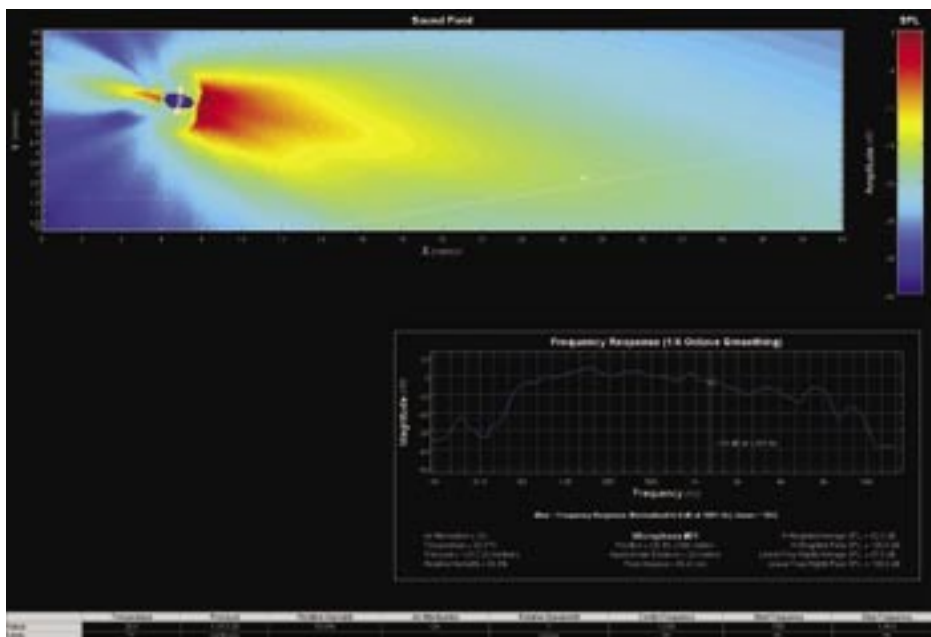

Figure 5.1. MAPP Online is an intuitive, powerful system design tool

Residing on your computer, the MAPP Online prediction program facilitates configuring arrays of a wide variety of Meyer Sound products and, optionally, defines the environment in which they will operate, including air temperature, pressure, and humidity, as well as the location and composition of walls. You can find the program at:

www.meyersound.com/products/software/mapponline

NOTE: In order to use the MAPP Online prediction program, you will need to register by clicking “Apply for MAPP Online” on the website listed above. After registration and upon approval, an e-mail will be sent to you with a user name and password along with the address for the website where you can download MAPP Online.

As its name indicates, the MAPP Online prediction program is an online application: When a prediction is requested, data is sent over the Internet to a high-powered server at Meyer Sound that runs a sophisticated acoustical prediction algorithm using high-resolution, complex (magnitude and phase) polar data. Predicted responses are returned over the Internet and displayed on your computer in color.

With the MAPP Online prediction program, you can:

- Plan an entire portable or fixed loudspeaker system and determine delay settings for fill loudspeakers.
- Clearly see interactions among loudspeakers and minimize destructive interference.
- Place microphones anywhere in the sound field and predict the frequency response, impulse response, and sound pressure level at the microphone position using MAPP Online’s Virtual SIM feature.
- Refine your system design to provide the best coverage of the intended audience area.
- Use a Virtual VX-1 program equalizer to predetermine the correct control settings for best system response.
- Gain valuable load information about the array to determine rigging capacities.

The MAPP Online prediction program enables you to come to an installation with a wealth of information that

ensures the system will satisfy your requirements “out of the box” – including basic system delay and equalization settings. Its accurate, high-resolution predictions eliminate unexpected onsite adjustments and coverage problems.

MAPP Online is compatible with Windows, Linux®, Unix®, and Apple® Macintosh® computers running Mac OS® X version 10.1.2 or higher. The MAPP Online Web page lists additional system requirements and recommendations.

SIM MEASUREMENT SYSTEM

The SIM audio analyzer is a measurement and instrumentation system including a selection of hardware and software options, microphones and accessory cables. The SIM analyzer is optimized for making audio frequency measurements of an acoustical system with a resolution of up to 1/24 of an octave; the high resolution enables you to apply precise electronic corrections to adjust system response using frequency and phase (time) domain information.

Source Independent Measurement Technique

The SIM audio analyzer implements Meyer Sound's source independent measurement technique, a dual-channel method that accommodates statistically unpredictable excitation signals. Any excitation signal that encompasses the frequency range of interest (even intermittently) may be used to obtain highly accurate measurements of acoustical or electronic systems. For example, concert halls and loudspeaker systems may be characterized during a musical performance using the program as the test signal, allowing you to:

- View measurement data as amplitude versus time (impulse response) or amplitude and phase versus frequency (frequency response)
- Utilize a single-channel spectrum mode
- View frequency domain data with a logarithmic frequency axis
- Determine and internally compensate for propagation delays using SIM Delay Finder function

Applications

The main application of the SIM audio analyzer is loudspeaker system testing and alignment. This includes:

- Measuring propagation delay between the subsystems to set correct polarities and set very precise delay times
- Measuring variations in frequency response caused by the acoustical environment and the placement and interaction of the loudspeakers to set corrective equalization
- Optimizing subwoofer integration
- Optimizing loudspeaker arrays

The SIM audio analyzer can also be used in the following applications:

- Microphone calibration and equalization
- Architectural acoustics
- Transducer evaluation and correction
- Echo detection and analysis
- Vibration analysis
- Underwater acoustics

CHAPTER 6: QUICKFLY RIGGING

The M2D and M2D-Sub loudspeakers feature Meyer Sound's QuickFly rigging system with rugged, reliable and deceptively simple components that remain captive, in transit. QuickFly rigging facilitates constructing rigid, ground-stacked or flown M2D-Sub arrays, and eases integration of M2D-Sub and M2D loudspeakers in unitary, full-range curvilinear arrays.

This chapter gives an overview of M2D and M2D-Sub rigging accessories. For complete information on how to set up and use the rigging accessories, refer to Meyer Sound's assembly guides at www.meyersound.com/products.



CAUTION: All Meyer Sound products must be used in accordance with local, state, federal, and industry regulations. It is the owner's and/or user's responsibility to evaluate the reliability of any rigging method for their application. Rigging should be carried out only by experienced professionals.

Fitted as standard on all M2D and M2D-Sub loudspeakers, the MRF-2D and MRF-2D-Sub rigging frames (Figure 6.1) also accommodates all the parts necessary to couple an M2D and M2D-Sub vertical array.

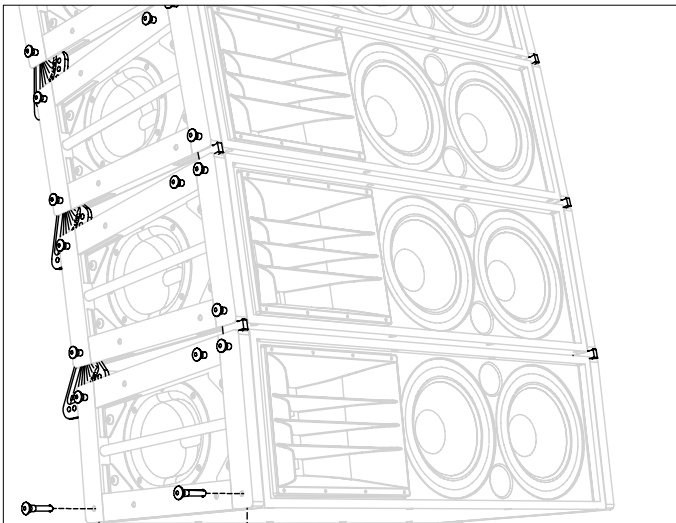

Figure 6.1. MRF-2D and MRF-2D-Sub Rigging Frames

The MRF-2D and MRF-2D-Sub rigging frames utilize CamLinks to connect adjacent cabinets, allowing vertical splay to be set from 0° to 7° using quick release pins (Figure 6.2). The CamLinks are easily reconfigured to allow arrays to be hung with the horns on the left or right side. The MRF-2D and MRF-2D-Sub frames provide a rigid angle between cabinets, maintaining the predetermined vertical splay as the array is tilted up or down.

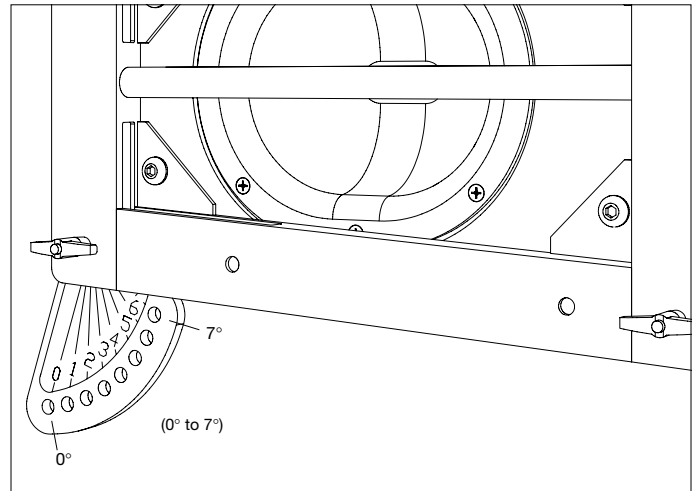

Figure 6.2. Vertical splay can be adjusted between 0° and 7° using CamLinks and quick release pins

MG-2D MULTIPURPOSE GRID

The MG-2D multipurpose grid (Figure 6.3) allows M2D and M2D-Sub loudspeakers to be flown or ground stacked.

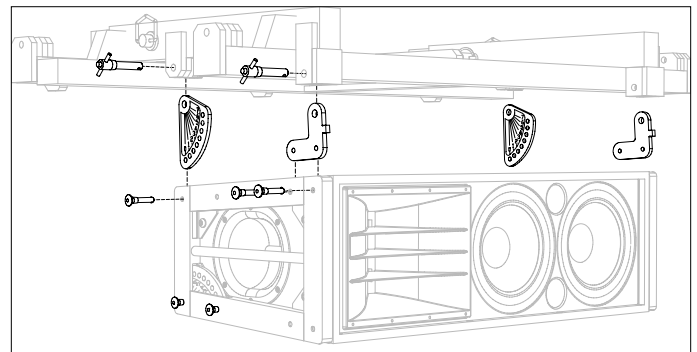

Figure 6.3. MG-2D multipurpose grid



TIP: See Meyer Sound's assembly guides on www.meyersound.com for more information on how to set up the M2D and M2D-Sub rigging accessories.

An adjustable rear extension frame provides flexibility for severe up-tilt and down-tilt in flown applications as well as increasing the stability in ground-stacked applications. Up to 16 M2D loudspeakers (or the equivalent weight of M2D and M2D-Sub cabinets) may be suspended from single or multiple rigging points of appropriate rating, with a safety factor of 7:1.

The MG-2D grid provides additional functionality, including transitioning to an M2D or M2D-Sub array from the bottom of a/an:

- M3D or M3D-Sub loudspeaker (MTK-2D transition kit required); or
- MILO loudspeaker (MTB-2D/M transition bar kit required)

MG-1D Multipurpose Grid

The MG-1D multipurpose grid (Figure 6.4) was originally designed to allow M1D and M1D-Sub loudspeakers to be flown or ground stacked. However, it can be used to fly M2D and M2D-Sub loudspeakers, when the flexibility of the MG-2D grid is not required.

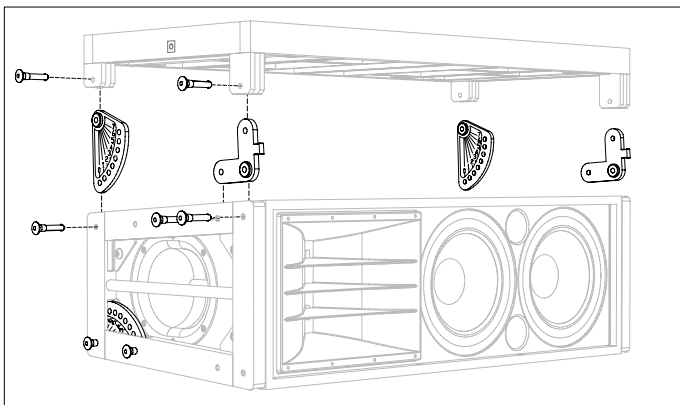

Figure 6.4. MG-1D multipurpose grid

Up to seven M2D loudspeakers (or the equivalent weight of M2D and M2D-Sub loudspeakers) may be suspended from single or multiple rigging points of appropriate rating, with a safety factor of 7:1.

The MG-1D grid provides additional functionality, such as transitioning from the bottom of an M2D and/or M2D-Sub array to:

- An M1D and/or M1D-Sub array;
- One UPA-1P compact wide coverage loudspeaker;
- Three UPA-2P compact narrow coverage loudspeakers;
- Two MSL-4 horn-loaded long-throw loudspeakers; or
- Two DS-4P horn-loaded mid-bass loudspeakers



CAUTION: The grid must never be suspended from the extension frame when used in this configuration.

APPENDIX A

TROUBLESHOOTING

This section contains possible solutions to some common problems encountered by M2D and M2D-Sub loudspeaker users and is not intended to be a comprehensive troubleshooting guide.

The On/Temp. LED (Active LED on M2D-Sub) does not illuminate and there is no audio.

1. Make sure the AC power cable is the correct type for the regional voltage and that it is securely connected to the AC inlet, then unplug and reconnect the AC cable.
2. Use an AC voltmeter to verify that the AC voltage is within the ranges 90 - 265 V AC.
3. If the On/Temp LED still fails to illuminate, call Meyer Sound Technical Support.

The On/Temp. LED (Active LED on M2D-Sub) is illuminated green but there is no sound.

1. Verify that the audio source (mixer, EQ, delay) is sending a valid signal.
2. Make sure the XLR cable is securely fastened to the XLR audio input connector.
3. Verify that the XLR cable is functioning by substituting another cable or by using the cable in question in a working system.
4. Send the audio signal to another loudspeaker to insure signal presence and that the level is within the proper range. Turn the source level down before reconnecting the audio input and increase the level slowly to avoid a sudden blast of sound.
5. If possible, monitor the audio source with headphones.

Hum or noise is produced by the loudspeaker.

1. Disconnect the audio input. If the noise persists, the problem is within the loudspeaker. In this case return the unit to the factory or nearest authorized service center. If the hum ceases, the noise originates somewhere earlier in the signal path.
2. Make sure the XLR cable is securely fastened to the XLR audio input connector.
3. Send the audio signal to another loudspeaker to insure signal presence and that the level is within the proper range. Turn the source level down before reconnecting the audio input and increase the level slowly to avoid a sudden blast of sound.
4. Hum or noise can be produced by a ground loop. Since the M2D and M2D-Sub loudspeakers are effectively ground-lifted, the loop must be broken elsewhere in the system.

The audio produced by the loudspeaker is distorted or compressed but the Limit LED is not illuminated.

1. Make sure the XLR cable is securely fastened to the XLR audio input connector.
2. Send the audio signal to another loudspeaker to insure that the level is within the proper range. Turn the source level down before reconnecting the audio input and increase the level slowly to avoid a sudden blast of sound.
3. Monitor the audio source with headphones.

The audio produced by the loudspeaker is highly compressed and the Limit LED is constantly yellow (red on M2D-Sub).

1. Turn down the level of the input signal to the loudspeaker system.

The On/Temp. LED (M2D) is illuminated red.

This occurs in conditions where the heatsink temperature reaches 85°C (185°F), indicating that the amplifier is thermally overloaded.

1. Turn down the level of the input signal to the loudspeaker system.
2. Make sure the fan is working properly.
3. Make sure there is sufficient air flow around the unit.
4. Avoid exposing the heatsink to direct sunlight if the ambient temperature is high.

See the amplification, limiting, cooling system sections beginning on page 10 for a complete discussion about the cooling system.

Only the high or low drivers seem to produce sound (M2D).

1. Make sure the audio signal is full-range and has not been filtered in a previous stage of the signal chain. If possible, monitor the audio source with high-quality headphones.
2. Send the audio signal to another loudspeaker to insure that the signal is full-range. Turn the source level down before reconnecting the audio input and increase the level slowly to avoid a sudden blast of sound.
3. Use a sine wave and/or pink noise generator to send a variety of frequencies to the loudspeaker.

APPENDIX B

M2D SPECIFICATIONS

ACOUSTICAL	
Note: The low-frequency power response of the system will increase according to the length of the array.	
Operating frequency range	60 Hz - 16 kHz Note: Recommended maximum operating frequency range. Response depends upon loading conditions and room acoustics.
Frequency response	70 Hz - 14 kHz ± 4 dB Note: Free field, measured with 1/3 octave frequency resolution at 4 meters.
Phase response	650 Hz - 12 kHz $\pm 45^\circ$
Maximum peak SPL	136 dB Note: Measured with music at 1 meter.
Dynamic range	>110 dB
Horizontal coverage	90°
Vertical coverage	Varies, depending on array length and configuration.
Acoustical crossover	575 Hz Note: At this frequency, the mid- and high-frequency transducers produce equal sound pressure levels.

TRANSDUCERS	
Low frequency	Two 10" cone drivers with neodymium magnets Nominal impedance: 4 Ω Voice coil size: 2" Power-handling capability: 400 W (AES) Note: Power handling is measured under AES standard conditions: transducer driven continuously for two hours with band limited noise signal having a 6 dB peak-average ratio.
Note: To eliminate interference at short wavelengths, the two 10" drivers work in combination at low frequencies (60 Hz – 350 Hz). At mid frequencies (350 Hz – 575 Hz) only one cone driver is fed from the crossover to maintain optimal polar and frequency response characteristics.	
High frequency	One 4" diaphragm compression driver Nominal impedance: 8 Ω Voice coil size: 4" Exit size: 1.5" Power-handling capability: 250 W (AES) Note: Power handling is measured under AES standard conditions: transducer driven continuously for two hours with band limited noise signal having a 6 dB peak-average ratio.

Note: The driver is coupled to a constant-directivity horn through a proprietary acoustical manifold (REM).

AUDIO INPUT	
Type	Differential, electronically balanced
Max. common mode range	± 15 V DC, clamped to earth for voltage transient protection
Connectors	Female XLR input with male XLR loop output or VEAM all-in-one connector (integrates AC, audio and network)
Input impedance	10 k Ω differential between pins 2 and 3
Wiring	Pin 1: Chassis/earth through a 220 k Ω , 1000 pF, 15 V clamp network to provide virtual ground lift at audio frequencies Pin 2: Signal +; Pin 3: Signal - Case: Earth ground and chassis
DC Blocking	Differential DC blocking up to max common mode voltage
CMRR	>50 dB, typically 80 dB (50 Hz – 500 Hz)

RF filter	Common mode: 425 kHz; Differential mode: 142 kHz
TIM filter	<80 kHz, integral to signal processing
Nominal input sensitivity	0 dBV (1 V rms, 1.4 V pk) continuous is typically the onset of limiting for pink noise and music.
Input level	Audio source must be capable of producing a minimum of +20 dBV (10 V rms, 14 V pk) into 600 ohms in order to produce maximum peak SPL over the operating bandwidth of the loudspeaker.

AMPLIFIER

Amplifier type	Two-channel complementary MOSFET output stages (class AB/bridged)
Output power	700 W total
	Note: Wattage rating is based on the maximum unclipped burst sine-wave rms voltage the amplifier will produce into the nominal load impedance — low channel 30 V rms (42 V pk); high channel 32 V rms (45 V pk)
THD, IM TIM	< .02%
Load capacity	2 Ω low channel, 8 Ω high channel
Cooling	Convection cooling. 24 V DC output for optional external fan.

AC POWER

AC power connector	PowerCon or VEAM
Voltage selection	Automatic
Safety agency rated operating voltage	100 V AC - 240 V AC; 50/60 Hz
Turn on/turn off points	Continuous 90 V AC - 265 V AC; 50/60 Hz
	Note: No automatic turn-off voltages. Voltages above 265 V AC are fuse protected but may cause permanent damage to the power supply. Voltages below 90 V AC may result in intermittent operation.

Current Draw

Idle current	0.35 A rms (115 V AC); 0.35 A rms (230 V AC); 0.35 A rms (100 V AC)
Max. long-term continuous current (>10 sec)	3.1 A rms (115 V AC); 1.6 A rms (230 V AC); 3.6 A rms (100 V AC)
Burst Current (<1 sec)	3.2 A rms (115 V AC); 1.6 A rms (230 V AC); 3.7 A rms (100 V AC)
Ultimate short-term peak current draw	5.8 A pk (115 V AC); 2.9 A pk (230 V AC); 6.7 A pk (100 V AC)
Inrush current	9 A pk (115 V AC); 9 A pk (230 V AC); 8 A pk (100 V AC)

RMS NETWORK

	Equipped for two conductor twisted-pair network, reporting all operating parameters of amplifiers to system operator's host computer.
--	---

PHYSICAL

Enclosure	Multi-ply hardwood
Finish	Black textured
Protective grille	Powder-coated hex stamped steel
Rigging	Patented QuickFly MRF-2D rigging frame with CamLinks and quick release pins
Dimensions	39.00" w x 12.12" h x 17.47" d (991 mm x 308 mm x 444 mm)

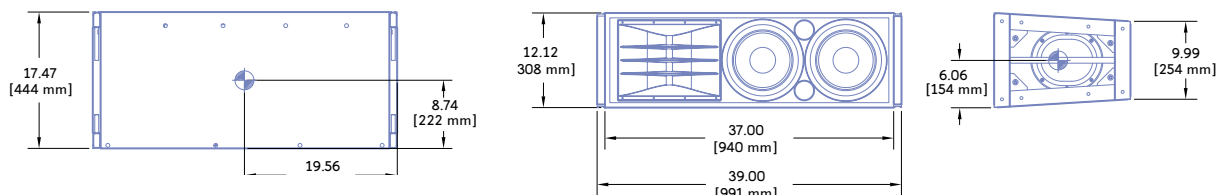

Weight	116 lbs (52.62 kg); Shipping 130 lbs (58.97 kg)
---------------	---

M2D-SUB SPECIFICATIONS

ACOUSTICAL	
Note: The low-frequency power response of the system will increase according to the length of the array.	
Operating frequency range	28 Hz - 160 Hz Note: Recommended maximum operating frequency range. Response depends upon loading conditions and room acoustics.
Frequency response	30 Hz - 140 Hz ± 4 dB Note: Free field, measured with 1/3 octave frequency resolution at 4 meters.
Phase response	40 Hz to 100 Hz $\pm 45^\circ$
Maximum peak SPL	138 dB Note: Measured with music at 1 meter.
Dynamic range	>110 dB
Horizontal coverage	360°
Vertical coverage	Varies, depending on array length and configuration.
TRANSDUCERS	
Low frequency	Two 15" cone drivers with neodymium magnets Nominal impedance: 4 Ω Voice coil size: 4" Power-handling capability: 1200 W (AES) Note: Power handling is measured under AES standard conditions: transducer driven continuously for two hours with band limited noise signal having a 6 dB peak-average ratio.
AUDIO INPUT	
Type	Differential, electronically balanced
Max. common mode range	± 15 V DC, clamped to earth for voltage transient protection
Connectors	Female XLR input with male XLR loop output or VEAM all-in-one connector (integrates AC, audio and network)
Input impedance	10 k Ω differential between pins 2 and 3
Wiring	Pin 1: Chassis/earth through a 220 k Ω , 1000 pF, 15 V clamp network to provide virtual ground lift at audio frequencies Pin 2: Signal + Pin 3: Signal - Case: Earth ground and chassis
DC Blocking	None on input; DC blocked through signal processing
CMRR	>50 dB, typically 80 dB (50 Hz – 500 Hz)
RF filter	Common mode: 425 kHz; Differential mode: 142 kHz
TIM filter	<80 kHz, integral to signal processing
Nominal input sensitivity	0 dB V (1 V rms, 1.4 pk) continuous is typically the onset of limiting for pink noise and music.

Input level	Audio source must be capable of producing a minimum of +20 dBV (10 V rms, 14 V pk) into 600 ohms in order to produce maximum peak SPL over the operating bandwidth of the loudspeaker.
-------------	--

AMPLIFIERS

Amplifier type	Two-channel complementary MOSFET output stages (class AB/H)
Output power	2250 W total
	Note: Wattage rating is based on the maximum unclipped burst sine-wave rms voltage the amplifier will produce into the nominal load impedance — both channels 67 V rms (95 V pk).
THD, IM TIM	< .02%
Load capacity	4 Ω each channel
Cooling	Forced air cooling, 2 fans total (1 ultrahigh-speed reserve fan)

AC POWER

AC power connector	PowerCon or VEAM
Voltage selection	Automatic, two ranges, each with high-low voltage tap (uninterrupted)
Safety agency rated operating voltage	95 V AC - 125 V AC; 208 V AC - 235 V AC; 50/60 Hz
Turn on/turn off points	85 V AC - 134 V AC; 165 V AC - 264 V AC; 50/60 Hz

Current Draw

Idle current	0.640 A rms (115 V AC); 0.320 A rms (230 V AC); 0.850 A rms (100 V AC)
Max. long-term continuous current (>10 sec)	8.8 A rms (115 V AC); 4.4 A rms (230 V AC); 10 A rms (100 V AC)
Burst Current (<1 sec)	19 A rms (115 V AC); 9.5 A rms (230 V AC); 22 A rms (100 V AC)
Ultimate short-term peak current draw	39 A pk (115 V AC); 20 A pk (230 V AC); 45 A pk (100 V AC)
Inrush current	7 A pk (115 V AC); 7 A pk (230 V AC); 10 A pk (100 V AC)

RMS NETWORK

	Equipped for two conductor twisted-pair network, reporting all operating parameters of amplifiers to system operator's host computer.
--	---

PHYSICAL

Enclosure	Multi-ply hardwood
Finish	Black textured
Protective grille	Powder-coated hex stamped steel
Rigging	Patented QuickFly MRF-2D-Sub rigging frame with CamLinks and quick release pins
Dimensions	39.00" w x 24.00" h x 17.50" d (991 mm x 610 mm x 445 mm)

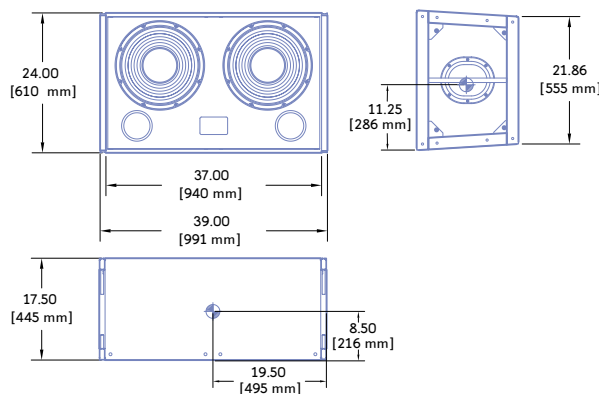

Weight	173 lbs (78.47 kg); Shipping: 197 lbs (89.35 kg)
--------	--

Meyer Sound Laboratories, Inc.
2832 San Pablo Avenue
Berkeley, CA 94702
USA

T: +1 510 486.1166
F: +1 510 486.8356
techsupport@meyersound.com
www.meyersound.com

© 2004
Meyer Sound Laboratories, Inc.
All Rights Reserved
05.112.012.01

Free Manuals Download Website

<http://myh66.com>

<http://usermanuals.us>

<http://www.somanuals.com>

<http://www.4manuals.cc>

<http://www.manual-lib.com>

<http://www.404manual.com>

<http://www.luxmanual.com>

<http://aubethermostatmanual.com>

Golf course search by state

<http://golfingnear.com>

Email search by domain

<http://emailbydomain.com>

Auto manuals search

<http://auto.somanuals.com>

TV manuals search

<http://tv.somanuals.com>