



Operating Instructions

MSL-6

Self-Powered Loudspeaker System



*Copyright © 1997 Meyer Sound Laboratories, Inc.
All rights reserved
Part # 05.053.026.01 Rev A*

Contents

Introduction	3	Complete Systems	8
AC Power	3	Driver Troubleshooting	10
Audio Input	5	Dimensions	12
Amplification and Protection Circuitry	6	Physical Construction	12
Rigging	7	Safety Summary	13
Measurement and System Integration	8	Controls and Connectors	14

Symbols Used

These symbols indicate important safety or operating features in this booklet and on the chassis.



Dangerous voltages: risk of electric shock	Important operating instructions	Frame or chassis	Protective earth ground
Pour indiquer les risques résultant de tensions dangereuses	Pour indiquer important instructions	Masse, châssis	Terre de protection
Zu die gefahren von gefährliche spanning zeigen	Zu wichtige betriebs- anweisung und unter- haltsanweisung zeigen	Rahmen oder chassis	Die schutzerde
Para indicar azares provengo de peligroso voltajes	Para indicar importante funcionar y mantenimiento instrucciones	Armadura o chassis	Tierra proteccionista

Declaration of Conformity

According to ISO/IEC Guide and EN 45014

The Manufacturer:

Name: Meyer Sound Laboratories Address: 2832 San Pablo Avenue Berkeley, California 94702-2204, USA
--

declares that the product:

Product Name: MSL-6 Product Options: All

conforms to the following Product Specifications:

Safety: EN 60065: 1994
EMC: EN 55022: 1987 - Class A
IEC 801-2: 1984 - 8 kV
IEC 801-3: 1984 - 3 V/m
IEC 801-4: 1984 - 0.5 kV Signal Lines, 1.0 kV Power Lines

The product herewith complies with the requirements of the Low Voltage Directive 73/23/EEC and the EMC Directive 89/336/EEC.

Office of Quality Manager
Berkeley, California USA
October 1, 1995

Environmental Specifications for Meyer Sound Electronics Products	
Operating temperature:	0° C to +45° C
Nonoperating temp:	< -40° C or > +75° C
Humidity:	to 95% at 35°C
Operating altitude:	to 4600 m (15,000 ft)
Nonoperating altitude:	to 6300 m (25,000 ft)
Shock:	30 g 11 msec half-sine on each of 6 sides
Vibration:	10 – 55 Hz (0.010 m peak-to-peak excursion)



Introduction

The MSL-6, Meyer Sound's largest self-powered speaker, is ideally suited for large-scale vocal public address applications as a stand-alone system, and for musical sound reinforcement in combination with Meyer self-powered subwoofers and/or the DS-2P mid-bass speaker. The MSL-6 features a 25° vertical coverage angle, permitting long-throw arrays with up to three vertical rows with minimal overlap between coverage areas.

The center and outer high frequency horns utilize separate amplifier and control electronics to achieve a 30° horizontal coverage angle for a single MSL-6. Tight-packing two units together yields a 60° coverage angle. Since the MSL-6 is intended for tight-packing only, array design is simple and modular: each additional unit increases the horizontal coverage by 30°. The maximum horizontal array size is twelve units, resulting in a circular array with 360° coverage.

The MSL-6 contains amplifier and control electronics for two 12" low frequency cone drivers and three high frequency horn drivers (2" throat, 4" diaphragm) in a compact trapezoidal cabinet. Each 12" driver is independently amplified and contained in a horn-loaded vented enclosure. This integrated design improves performance, durability, and reliability, eliminates amplifier racks, and simplifies setup and installation.

The MSL-6 can be equipped to operate with the **Remote Monitoring System** (RMS™) network and software application. RMS displays signal and power levels, driver and cooling fan status, limiter activity, and amplifier temperature for all speakers in the network on a Windows-based PC. Contact Meyer Sound for more information about RMS.

AC Power

When AC power is applied to the MSL-6, the **Intelligent AC™** supply automatically selects the correct operating voltage, allowing the MSL-6 to be used internationally without manually setting voltage switches. The Intelligent AC supply performs the following protective functions to compensate for hostile conditions on the AC mains:

- suppresses high voltage transients up to several kilovolts
- filters common mode and deference mode radio frequencies (EMI)
- sustains operation during low voltage periods
- provides soft-start power-up, which eliminates high inrush current

The MSL-6 can withstand continuous voltages up to 275 V and allows any combination of voltage to GND (i.e. Neutral-Hot-GND, Hot-Hot-GND). Continuous voltages higher than 275 V may damage the unit.

The MSL-6 uses a NEMA L6-20P or IEC 309 male power inlet and satisfies UL, CSA, and EC safety standards.

Voltage Requirements

The MSL-6 operates safely and without audio discontinuity if the AC voltage stays within either of two operating windows: 85–134 V or 165–264 V, at 50 or 60 Hz. After applying AC power, the proper operating voltage is automatically selected, but the system is muted. During the next three seconds, the primary fans turn on, the main power supply slowly ramps on, the green **Active** LED on the user panel illuminates, and the system is enabled to pass audio signals.

***TROUBLESHOOTING NOTE:** If the Active LED does not illuminate or the system does not respond to audio input after ten seconds, remove AC power. Electronics technicians with access to a test bench can contact Meyer Sound to receive The Meyer Sound Self-Powered Series MP-2 and MP-4 Field Verification Procedure (part # 17.022.066.01). This service document contains a series of tests to verify that the power supply and amplifier are functioning properly. Other users should contact Meyer Sound or an authorized service center.*

If the voltage decreases below the lower bound of either operating range (*brown-out*), the supply uses stored energy to continue functioning briefly. The unit turns off if the voltage does not increase above the threshold before the storage circuits are depleted. The time that the MSL-6 continues to operate during brown-out depends on how low the voltage drops and the audio source level during this period.

If the voltage fluctuates *within* either operating range, automatic tap selection stabilizes the internal operating voltage. This tap selection is instantaneous and there are no audible artifacts. If the voltage increases above the upper bound of either range, the power supply turns off rapidly, preventing damage to the unit.

If the MSL-6 shuts down due to either low or high voltage, the power supply automatically turns on after three seconds if the voltage has returned to either normal operating range. If the MSL-6 does not turn back on after ten seconds, remove AC power and refer to the *TROUBLESHOOTING NOTE* above.

NOTE: We recommend that the supply be operated at least a few volts away from either window's upper and lower bounds so that small AC voltage variations do not cause the supply to cycle on and off.

Current Requirements

The MSL-6 presents a dynamic load to the AC mains which causes the amount of current to fluctuate between quiet and loud operating levels. Since different types of cables and circuit breakers heat up at varying rates, it is essential to understand the types of current ratings and how they correspond to circuit breaker and cable specifications.

The **maximum continuous RMS** current is the maximum RMS current in a period of at least 10 seconds. It is used to calculate the temperature increase in cables, which is used to select cables that conform to electrical code standards. It is also used to select the rating for slow-reacting thermal breakers.

The **maximum burst RMS** current is the maximum RMS current in a period of approximately 1 second. It is used to select the rating for most magnetic breakers.

The **maximum instantaneous peak current during burst** is used to select the rating for fast-reacting magnetic breakers and to calculate the peak voltage drop in long AC cables according to the formula

$$V_{pk_drop} = I_{pk} \times R_{total\ cable}$$

Use the table below as a guide to select cables and circuit breakers with appropriate ratings for your operating voltage.

MSL-6 Current Ratings			
	115 V	230 V	100 V
Max. Continuous RMS	14 A _{RMS}	7 A _{RMS}	16 A _{RMS}
Max. Burst RMS	26 A _{RMS}	13 A _{RMS}	30 A _{RMS}
Max. Peak During Burst	38 A _{PEAK}	18 A _{PEAK}	42 A _{PEAK}

The minimum electrical service amperage required by a system of MSL-6s is the sum of their **maximum continuous RMS current**. We recommend allowing an additional 30% above the minimum amperage to prevent peak voltage drops at the service entry.

TROUBLESHOOTING NOTE: In the unlikely case that the circuit breakers trip (the white center buttons pop out), do not reset the breakers! Contact Meyer Sound for repair information.

Power Connector Wiring Conventions

Use the following AC cable wiring diagram to create international or special-purpose power connectors:

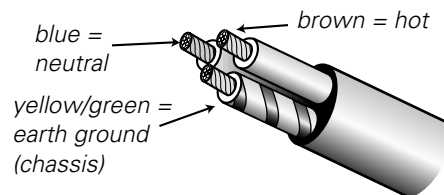

AC cable color code

If the colors referred to in the diagram don't correspond to the terminals in your plug, use the following guidelines:

- Connect the blue wire to the terminal marked with an *N* or colored black.
- Connect the brown wire to the terminal marked with an *L* or colored red.
- Connect the green and yellow wire to the terminal marked with an *E* (or \oplus) or colored green (or green and yellow).

Safety Issues

Pay close attention to these important electrical and safety issues.

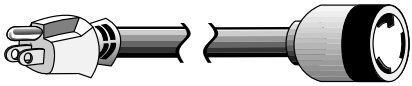

Use a power cord adapter to drive the MSL-6 from a standard 3-prong outlet (NEMA 5-15R; 125 V max).



earth
ground

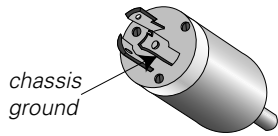

chassis
ground



The MSL-6 requires a grounded outlet. Always use a grounding adapter when connecting to ungrounded outlets.

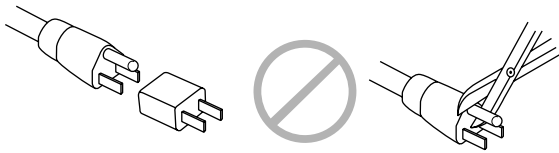

Do not use a ground-lifting adapter or cut the AC cable ground pin.



Keep all liquids away from the MSL-6 to avoid hazards from electrical shock.

Do not operate the unit if the power cables are frayed or broken.

Tie-wrap anchors on the amplifier chassis provide strain relief for the power and signal cables. Insert the plastic tie-wraps through the anchors and wrap them around the cables.

Audio Input

The MSL-6 presents a 10 k Ω balanced input impedance to a three-pin XLR connector wired with the following convention:

Pin 1 — 220 k Ω to chassis and earth ground (ESD clamped)

Pin 2 — Signal — Differential Inputs

Pin 3 — Signal — Differential Inputs

Case — Earth (AC) ground and chassis

Pins 2 and 3 carry the input as a differential signal; their polarity can be reversed with the **input polarity switch** on the user panel. If the switch is in the up position, pin 2 is hot relative to pin 3, resulting in a positive pressure wave when a positive signal is applied to pin 2. Use standard audio cables with XLR connectors for balanced signal sources.

***TROUBLESHOOTING NOTE:** Shorting an input connector pin to the case can form a ground loop and cause hum. If other abnormal noises (hiss, popping) are produced from the loudspeaker, disconnect the audio source from the speaker. If the noise stops, then the problem is not within the loudspeaker; check the audio input and AC power.*

A single source can drive multiple MSL-6s with a paralleled input loop, creating an unbuffered hardwired loop connection. Make certain that the source device can drive the total load impedance presented by the paralleled input circuit. For example, since the input impedance of a single MSL-6 is 10 k Ω , cascading 20 units produces a balanced input impedance of 500 Ω . If a 150 Ω source is used, the 500 Ω load results in a 2.28 dB loss.

Amplification and Protection Circuitry

The MSL-6 is powered by the Meyer MP-4, a four-channel 2480 W amplifier (620 W/ch) utilizing complementary power MOSFET output stages (class AB/H). The following sections discuss the MP-4's limiting circuitry and four-fan cooling system.

The TruPower™ Limiting System

Conventional limiters assume that the resistance of a speaker remains constant and set the limiting threshold by measuring voltage only. This method is inaccurate because the speaker's resistance changes in response to the frequency content of the source material and thermal variations in the speaker's voice coil and magnet. Conventional limiters begin limiting prematurely, which under-utilizes system headroom and deprives the speaker of its full dynamic range.

The TruPower Limiting (TPL) system accounts for varying speaker impedance by measuring current, in addition to voltage, to compute the actual power dissipation in the voice coil. TPL

- improves performance before and during limiting by allowing each driver to produce its maximum SPL across its entire frequency range;
- protects the drivers by controlling the temperature of the voice coil;
- eliminates long-term power compression when the system is operated at high levels for extended periods.

The true power is monitored for each of the four amplifier channels, which are controlled by two limiters. The outer two and center high frequency drivers are driven by separate amplifier channels but are routed to one limiter: the **HI Limit** LED on the user panel indicates TPL activity for the horns. The two low frequency drivers are driven by separate amplifier channels but are routed to one limiter: the **LO Limit** LED indicates TPL activity for the low drivers.

When any channel exceeds the safe continuous power level, its limiter engages, affecting both channels equally. For example, if the channel for the outer two horns exceeds the safe power level, the high limiter engages, limiting the center, as well as the outer two horns. The high and low limiters function independently and do not affect the signal when the LEDs are inactive.

The MSL-6 performs within its acoustical specifications and operates at a normal temperature if the limit LEDs are on for no longer than two seconds, and off for at least one second. If either LED remains on for longer than three seconds, that channel is *hard limiting* with the following negative consequences:

- Increasing the input level will not increase the volume.
- The system distorts due to clipping and nonlinear driver operation.
- Unequal limiting between the low and high channels alters the frequency response.
- The life-span of the drivers is reduced because they are subjected to excessive heat.

The TPL LEDs can indicate an imbalance in a configuration of speakers by functioning like a spectrum analyzer. If the speakers in a subwoofer, mid-bass, or mid-hi subsystem begin to limit before reaching the required operating level for the entire system, then that subsystem needs to be supplemented with additional speakers.

NOTE: Although the TPL limiters exhibit smooth sonic characteristics, we do not recommend using them for intentional compression effects. Use an outboard compressor/limiter to compress a mixed signal.

VHF Limiting

At normal operating levels, the outer two horns receive a high frequency boost (centered at 11 kHz) to blend with the center horn to achieve smooth horizontal coverage. At high operating levels, however, this boost can cause distortion and premature TPL limiting.

To preserve headroom and maintain smooth high frequency response at high operating levels, the channel for the outer two horns has a fast-acting VHF (very high frequency) limiter that reduces the amplitude of frequencies around 11 kHz. Increased acoustical HF harmonic content generated at high signal levels compensates for the effects of the VHF limiter, rendering its operation almost imperceptible. VHF limiting is indicated by the **VHF Limit** LED on the user panel; the same on/off cycle discussed for the TPL limiters applies to the VHF limiter.

Fans and Cooling System

The MSL-6 uses a forced-air cooling system with four fans to prevent the amplifiers from overheating. The fans draw air in through ducts on the front of the cabinet, over the heatsinks, and out the rear of the cabinet. Since dust does not accumulate in the amplifier circuitry, its life-span is increased significantly.

The front grill surface acts as an air filter for the cooling system and should always be in place during operation. Despite the filtering, extensive use or a dusty operating environment can allow dust to accumulate along the path of the airflow, preventing normal cooling. We recommend periodically removing the grill and amplifier module and using a vacuum cleaner to clear dust from the grill, fans, and heatsinks. Make sure that the air ducts are clear and that there is at least six inches clearance for exhaust behind the cabinet.

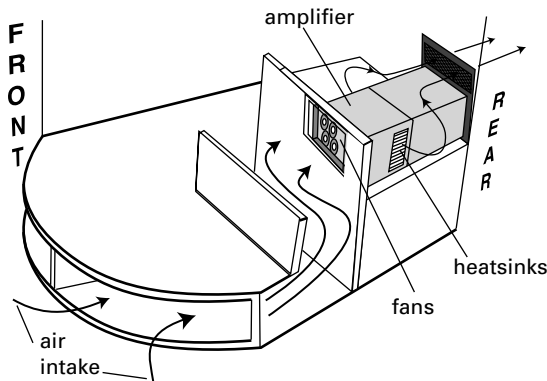

Two variable-speed primary fans run continuously with an inaudible operating noise of 22 dBA at 1 m at their slowest speed. The primary fans begin increasing speed when either of the two heatsinks reaches 42°C. The fans reach full speed at 62°C and are barely audible near the cabinet, even without an audio signal.

In the unusual event that the heatsink temperature reaches 74°C, the secondary fans turn on and are clearly audible. The secondary fans turn on in response to

- primary fan failure (check status immediately);
- high source levels for a prolonged period in hot temperatures or direct sunlight;
- accumulation of dust along the cooling path;
- driver failure.

The secondary fans turn off when the temperature decreases to 68°C.

TROUBLESHOOTING NOTE: In the highly unlikely event that the secondary fans do not keep the temperature below 85°C, the MSL-6 automatically shuts down until AC power is removed and reapplied. If the MSL-6 shuts down again after cooling and reapplying AC power, contact Meyer Sound for repair information.

Rigging

A single MSL-6 weighs 510 lb (282 kg) and has twelve pivoting lift rings (six on top, six on bottom), each with a maximum working load capacity of 1500 lb (5:1 safety factor). The rigging hardware is depicted on page 12 in the *Dimensions* section.

Rigging load ratings assume a straight tensile pull and that the cabinet is in new condition. If these conditions are not met, the load ratings can be reduced significantly. Load ratings can also be reduced by age, wear, and damage. It is important to inspect the rigging hardware regularly and replace worn or damaged components immediately.

The cabinet, exposed electronic circuitry, and drivers can receive protective treatment that permits safe use in wet conditions. Additionally, a rain hood can be fitted to shield cables and electronics. *Do not install a unit outdoors without weather protection!* Contact Meyer Sound for more information.

NOTE: All Meyer Sound products must be used in accordance with local, state, federal, and industry regulations. It is the owner's and/or user's responsibility to evaluate the reliability of any rigging method for their application. Rigging should be done only by experienced professionals.

Measurement and System Integration

Measurement and correction tools are required to assemble a complete sound system, particularly when the venue requires precise array design, delay systems, or compensation for significant reverberation. We recommend using the Meyer **SIM® System II Sound Analyzer** and **CP-10 Parametric Equalizer** to

- assist the process of choosing and configuring speakers;
- measure propagation delays between subsystems to set the correct polarity and delay times;
- measure and equalize variations in frequency response caused by the acoustical environment and the placement and interaction of speakers.

We recommend using the Meyer **LD-1A Line Driver** to integrate different types of Meyer self-powered speakers into a complete system. The LD-1A has two channels equipped to control a main system and six auxiliary channels for down-fill, front-fill, and delay systems. The LD-1A maintains signal integrity for long cable paths and provides the following useful functions:

- The **Lo Cut** switch activates a high-pass filter (160 Hz, -12 dB/oct, Q = 0.8) that performs a crossover function for the Mid-Hi output.
- The **Array EQ** switch activates a filter (6 dB cut at 220 Hz, 0.6 octave bandwidth) to equalize horizontal arrays of 3 to 5 MSL-4s.
- The **DS-2 & Sub Crossover** switch (channels 1 and 2 only) activates a crossover network optimized for the DS-2P when used with the 650-P. With the switch **in**, frequencies below 80 Hz are sent to the Sub output (for the 650-P), and above 80 Hz to the DS-2 output. When the 650-P is used without the DS-2P, the switch should be **out**, which sends a full-range signal to both the DS-2 and Sub outputs.
- The **DS-2 ϕ** and **Sub ϕ** switches (channels 1 and 2 only) toggle the polarity for the DS-2 and Sub outputs.
- The **Mid-Hi**, **DS-2**, and **Sub** outputs (channels 1 and 2 only) each have their own gain control and mute switch.

***POLARITY NOTE:** The polarity for Meyer self-powered speakers may be reversed using the input polarity switch on the user panel. The LD-1A also allows polarity reversal with the DS-2 ϕ and Sub ϕ switches for speakers connected to the DS-2 and Sub outputs. When making polarity decisions in applications that include the LD-1A, check the state of all polarity switches.*

Complete Systems

Meyer Speaker Types

The following Meyer speakers are mentioned in the example applications.

MSL-4	Self-powered mid-hi speaker
DS-2P	Self-powered mid-bass speaker
PSW-2	Self-powered subwoofer
650-P	Self-powered subwoofer

The Meyer self-powered speakers listed above have a **loop** connection to send the input signal to another speaker. Full-range signals can be applied to all Meyer self-powered subwoofers because they have built-in active crossovers that filter mid-hi frequencies.

Flown MSL-6 and MSL-4; 650-P on the Floor

This example shows a large concert system controlled by the LD-1A consisting of two rows of two MSL-6s (lower row at 10° to the top row), one row of two MSL-4s with a 30° horizontal splay angle (hung below lower MSL-6 at 20°), and 650-Ps on the floor. The diagram on the next page displays connections for half of a complete system; channels 2, 4, and 6 can be used with identical connections to create the other half.

The CH 1 Mid-Hi and CH 3 outputs drive the upper and lower MSL-6 arrays, respectively. Since the coverage areas of the upper and lower MSL-6 arrays intersect to some degree, CH 3 is delayed to phase align the upper and lower systems. The Lo Cut switches for the CH 1 Mid-Hi and CH 3 outputs should be **in**. The number of MSL-6s for each row depends on the horizontal coverage required by the system; each tight-packed unit adds 30°. Refer to the MSL-4 and 650-P Operating Instructions to design arrays for those speakers.

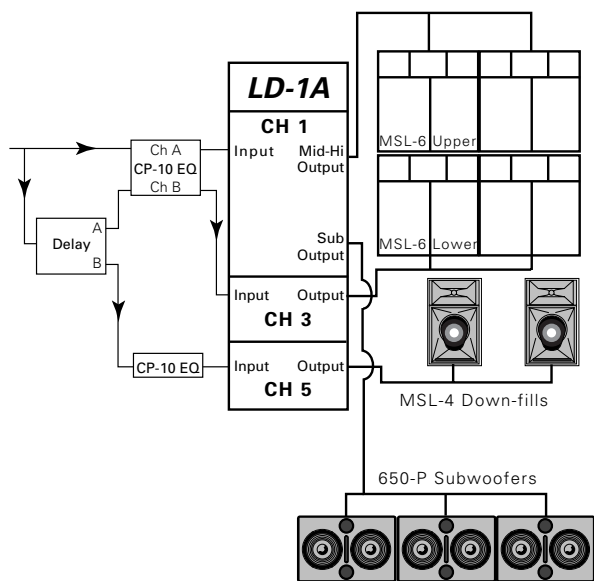

CH 5 controls the MSL-4 down-fill system. Since the main system is more powerful than the down-fill system to project farther into the venue, the main system is audible in the down-fill's coverage area. To insure that the systems combine properly in this area:

- Set the MSL-4 to the same polarity as the MSL-6 to phase align the mid-hi frequencies.
- Use the CH 5 Array EQ filter to minimize the low-mid rise caused by the MSL-4 array.
- Delay the down-fill to align it with the lower MSL-6 system in their intersecting coverage area.

The polarity for the 650-P depends on the height and distance of the measurement position from the flown and subwoofer systems. The entire system should be measured, phase-aligned, and equalized using the SIM System II Sound Analyzer and CP-10 Parametric Equalizer.

Flown MSL-6, DS-2P, and MSL-4; 650-P on the Floor

The system from the previous example can be supplemented with a row of four DS-2Ps (or PSW-2s), suspended below the lower MSL-6 array, to reinforce the low frequencies. The MSL-4s are hung below the DS-2Ps at 20°.

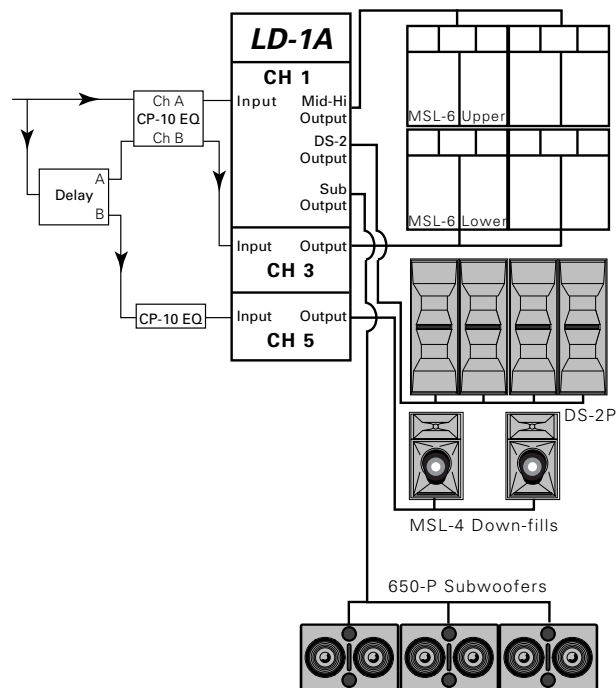

The connections for this system are the same as the previous example except that the CH1 DS-2 output drives the DS-2P system with the DS-2 & Sub Crossover switch **in**. The lower MSL-6 system should be delayed to align with the upper MSL-6 system in the area in which their coverage overlaps. The MSL-4 should also be delayed to align with the lower MSL-6 system.

Refer to the Operating Instructions for the MSL-4, 650-P, and DS-2P (or PSW-2) to design arrays for those speakers.

The MSL-6, MSL-4, and DS-2P systems should be set to the same polarity. The polarity for the 650-P depends on the height and distance of the measurement position from the flown and subwoofer systems.

The entire system should be measured, phase-aligned, and equalized using the SIM System II Sound Analyzer and CP-10 Parametric Equalizer.

Driver Troubleshooting

The Remote Monitoring System (RMS) is the best method to query the status of the drivers in a system before and during the performance. RMS monitors peak power, peak voltage, and average voltage (VU) for each amplifier channel, allowing immediate detection and muting for drivers with open or shorted voice coils, with minimal disruption to the system. Contact Meyer Sound for more information about RMS.

In the absence of RMS, several methods can be employed to obtain information about the state of the drivers.

Driver Troubleshooting with TPL

The TPL LEDs can indicate serious driver problems, if interpreted correctly. If one MSL-6 in a system exhibits substantially more TPL activity than others receiving the same audio signal, then one of the drivers corresponding to the excessively active LED may have a short circuit. This is a potentially dangerous condition for the electronics; shut the MSL-6 down immediately.

The TPL circuit does not activate if there is no power dissipation in the driver, regardless of the input signal level. Therefore, if all MSL-6s in a system receiving the same audio signal exhibit TPL activity except one, then that unit may have an open voice coil; disconnect it and contact Meyer Sound for repair information.

Removal, Inspection, and Replacement

To determine whether a low or high frequency driver is functioning properly, or replace a damaged driver, contact Meyer Sound to obtain the *Low Driver Inspection and Evaluation Procedure for Self-Powered Series Products* (part # 17.010.120.01) or the *High Driver Inspection and Evaluation Procedure for Self-Powered Series Products* (part # 17.010.120.02). These documents are accurate for inspection and verification but have yet to be updated for the different driver removal procedure for the MSL-6.

The MSL-6 has two rear hatch covers that must be removed to access the high and low drivers. Remove the screws for either hatch with a Phillips screwdriver. The hatch is sealed with a rubber gasket so it must be pulled off with moderate force.

Use a $\frac{7}{16}$ " open-end wrench to remove the nuts that secure the high driver to the horn. Hold the driver as the final nut is removed to prevent it from falling. Twist the driver sideways and up/down to remove it from the back of the cabinet.

Use a $\frac{3}{16}$ " hex wrench to remove the nuts that mount the low driver. Support the driver as the last nut is removed to prevent it from falling. Twist the driver sideways and up/down to remove it from the back of the cabinet.

Verifying Polarity

Incorrect driver polarity impairs system performance and may damage the drivers. All Meyer Sound loudspeakers are shipped with the drivers in correct alignment. However, if the driver or circuit wiring has been removed or disassembled in any loudspeaker in a system for any reason, check the polarity between adjacent loudspeakers and between drivers in the same cabinet.

We recommend that SIM System II be used to check polarity but a real-time frequency analyzer with one-third octave resolution is adequate.



Since polarity reversal causes excessive driver excursion at high source levels, use moderate levels when conducting these tests.

Driver Polarity in the Same Loudspeaker

Use the following test procedure to verify polarity between high frequency horn drivers:

1. Place a monitoring microphone 5 ft from the grill frame, 8.5" below the top of the speaker, at the mid-point of the center horn (center-line of cabinet).
2. Connect a signal source to the loudspeaker and note the frequency response.

The polarity of the high drivers is correct if the frequency response is ± 3 dB 1 – 4 kHz. Polarity reversal for the center or outer horns is indicated by 12 – 15 dB cancellation in the same region. Check the wiring to the high frequency drivers and to the MP-4 and correct the problem.

Use the following test to verify polarity between low frequency drivers:

1. Place a monitoring microphone 5 ft from the grill frame, 28" below the top of the cabinet, at the mid-point between low drivers (center-line of cabinet).
2. Connect a signal source to the loudspeaker and note the frequency response.

The polarity of the low drivers is correct if the frequency response is ± 3 dB 125 – 500 Hz. Polarity reversal for one of the low drivers is indicated by 12 – 15 dB cancellation in the same region. Check the wiring to the low drivers and to the MP-4 and correct the problem.

Use the following test to verify polarity between high and low frequency drivers:

1. Place a monitoring microphone 5 ft from the grill frame, 24" below the top of the cabinet, at the mid-point between low drivers (center-line of cabinet).
2. Connect a signal source to the loudspeaker and note the frequency response.

The polarity is correct if the frequency response is ± 3 dB 500 Hz – 1 kHz. Polarity reversal is indicated by a 6 – 12 dB cancellation in the same range.

Polarity Between Adjacent Loudspeakers

Use the following test procedure to verify the polarity between adjacent MSL-6 loudspeakers:

1. Position two loudspeakers adjacent to each other.
2. Place a measurement microphone six ft from the speakers on the axis between them.
3. Connect a signal source to one speaker and note the frequency response and overall level.
4. Apply the same signal to the second speaker with the first speaker still connected.

The polarity is correct if the frequency response remains constant with a significant increase in amplitude. Broad-band cancellation (decreased overall level) indicates polarity reversal.

Phase Poppers

We do not recommend using phase poppers to analyze driver polarity. The phase response for all drivers varies, to some degree, over the frequency range in which it operates. Since phase poppers do not discern variations in phase with respect to frequency, they do not provide accurate information about the phase response through the crossover.

Phase poppers are, therefore, not useful for performing phase measurements on individual loudspeakers or full-range sound systems containing one or more crossovers. If necessary, apply a phase popper only to loudspeakers with identical drivers without a crossover, and check the overall system phase response with a frequency analyzer and/or listening test.

Dimensions

All units in inches

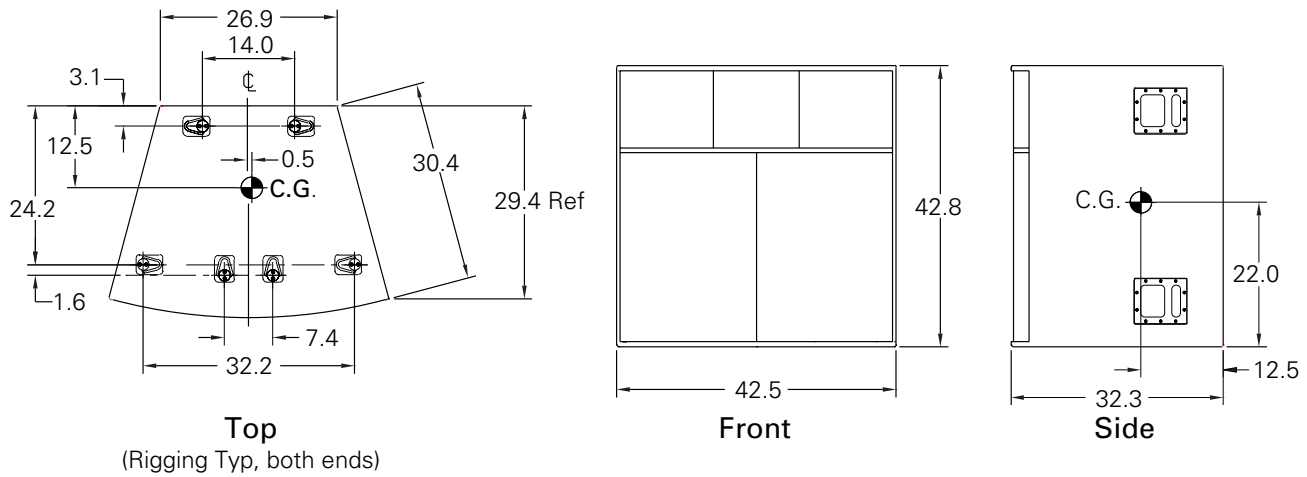

Physical Construction

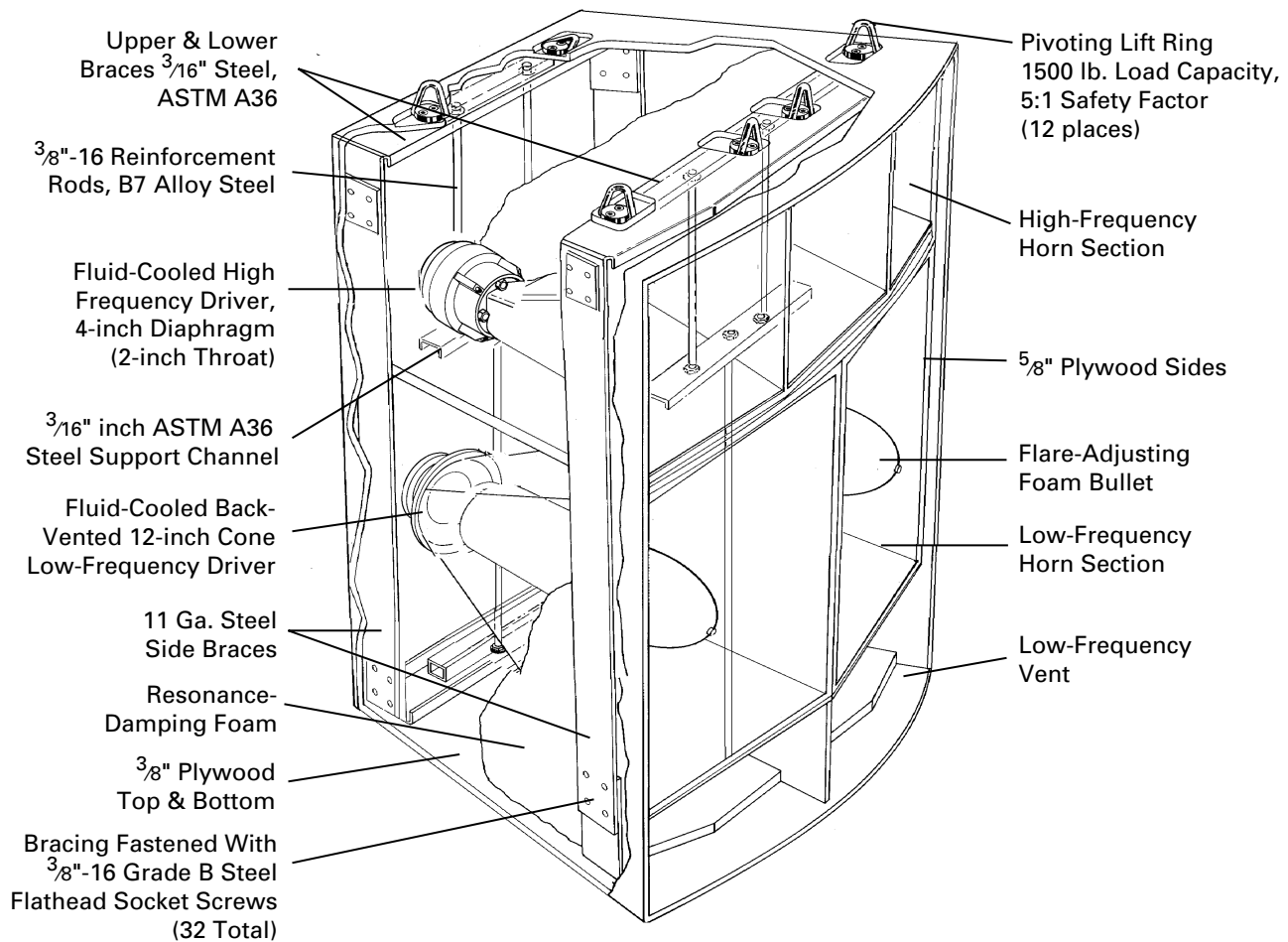



Safety Summary



English

- To reduce the risk of electric shock, disconnect the loudspeaker from the AC mains before installing audio cable. Reconnect the power cord only after making all signal connections.
- Connect the loudspeaker to a two-pole, three wire grounding mains receptacle. The receptacle must be connected to a fuse or circuit breaker. Connection to any other type of receptacle poses a shock hazard and may violate local electrical codes.
- Do not install the loudspeaker in wet or humid locations without using weather protection equipment from Meyer Sound.
- Do not allow water or any foreign object to get inside the loudspeaker. Do not put objects containing liquid on, or near, the unit.
- To reduce the risk of overheating the loudspeaker, avoid exposing it to direct sunlight. Do not install the unit near heat emitting appliances, such as a room heater or stove.
- This loudspeaker contains potentially hazardous voltages. Do not attempt to disassemble the unit. The unit contains no user serviceable parts. Repairs should be performed only by factory trained service personnel.

Français

- Pour réduire le risque d'électrocution, débrancher la prise principale de l'haut-parleur, avant d'installer le câble d'interface allant à l'audio. Ne rebrancher le bloc d'alimentation qu'après avoir effectué toutes les connexions.
- Branchez l'haut-parleur dans une prise de courant à 3 dérivations (deux pôles et la terre). Cette prise doit être munie d'une protection adéquate (fusible ou coupe-circuit). Le branchement dans tout autre genre de prise pourrait entraîner un risque d'électrocution et peut constituer une infraction à la réglementation locale concernant les installations électriques.
- Ne pas installer l'haut-parleur dans un endroit où il y a de l'eau ou une humidité excessive.
- Ne pas laisser de l'eau ou tout objet pénétrer dans l'haut-parleur. Ne pas placer de récipients contenant un liquide sur cet appareil, ni à proximité de celui-ci.
- Pour éviter une surchauffe de l'haut-parleur, conserver-la à l'abri du soleil. Ne pas installer à proximité d'appareils dégageant de la chaleur tels que radiateurs ou appareils de chauffage.
- Ce haut-parleur contient des circuits haute tension présentant un danger. Ne jamais essayer de le démonter. Il n'y a aucun composant qui puisse être réparé par l'utilisateur. Toutes les réparations doivent être effectuées par du personnel qualifié et agréé par le constructeur.

Deutsch

- Um die Gefahr eines elektrischen Schlages auf ein Minimum zu reduzieren, den Lautsprecher vom Stromnetz trennen, bevor ggf. ein Audio-Schnittstellensignalkabel angeschlossen wird. Das Netzkabel erst nach Herstellung aller Signalverbindungen wieder einstecken.
- Der Lautsprecher an eine geerdete zweipolige Dreiphasen-Netzsteckdose anschließen. Die Steckdose muß mit einem geeigneten Abzweigschutz (Sicherung oder Leistungsschalter) verbunden sein. Der Anschluß der unterbrechungsfreien Stromversorgung an einen anderen Steckdosentyp kann zu Stromschlägen führen und gegen die örtlichen Vorschriften verstoßen.
- Der Lautsprecher nicht an einem Ort aufstellen, an dem sie mit Wasser oder übermäßig hoher Luftfeuchtigkeit in Berührung kommen könnte.
- Darauf achten, daß weder Wasser noch Fremdkörper in das Innere den Lautsprecher eindringen. Keine Objekte, die Flüssigkeit enthalten, auf oder neben die unterbrechungsfreie Stromversorgung stellen.
- Um ein Überhitzen dem Lautsprecher zu verhindern, das Gerät vor direkter Sonneneinstrahlung fernhalten und nicht in der Nähe von wärmeabstrahlenden Haushaltsgeräten (z.B. Heizgerät oder Herd) aufstellen.
- Im Inneren diesem Lautsprecher herrschen potentiell gefährliche Spannungen. Nicht versuchen, das Gerät zu öffnen. Es enthält keine vom Benutzer reparierbaren Teile. Reparaturen dürfen nur von ausgebildetem Kundendienstpersonal durchgeführt werden.

Español

- Para reducir el riesgo de descarga eléctrica, desconecte de la red el altoparlante antes de instalar el cable de señalización de interfaz de la segnale. Vuelva a conectar el conductor flexible de alimentación solamente una vez efectuadas todas las interconexiones de señalización.
- Conecte el altoparlante a un tomacorriente bipolar y trifilar con neutro de puesta a tierra. El tomacorriente debe estar conectado a la protección de derivación apropiada (ya sea un fusible o un disyuntor). La conexión a cualquier otro tipo de tomacorriente puede constituir peligro de descarga eléctrica y violar los códigos eléctricos locales.
- No instale el altoparlante en lugares donde haya agua o humedad excesiva.
- No deje que en el altoparlante entre agua ni ningún objeto extraño. No ponga objetos con líquidos encima de la unidad ni cerca de ella.
- Para reducir el riesgo de sobrecalentamiento, no exponga la unidad a los rayos directos del sol ni la instale cerca de artefactos que emiten calor, como estufas o cocinas.
- Este altoparlante contiene niveles de voltaje peligrosos en potencia. No intente desarmar la unidad, pues no contiene piezas que puedan ser reparadas por el usuario. Las reparaciones deben efectuarse únicamente por parte del personal de mantenimiento capacitado en la fábrica.

Controls and Connectors

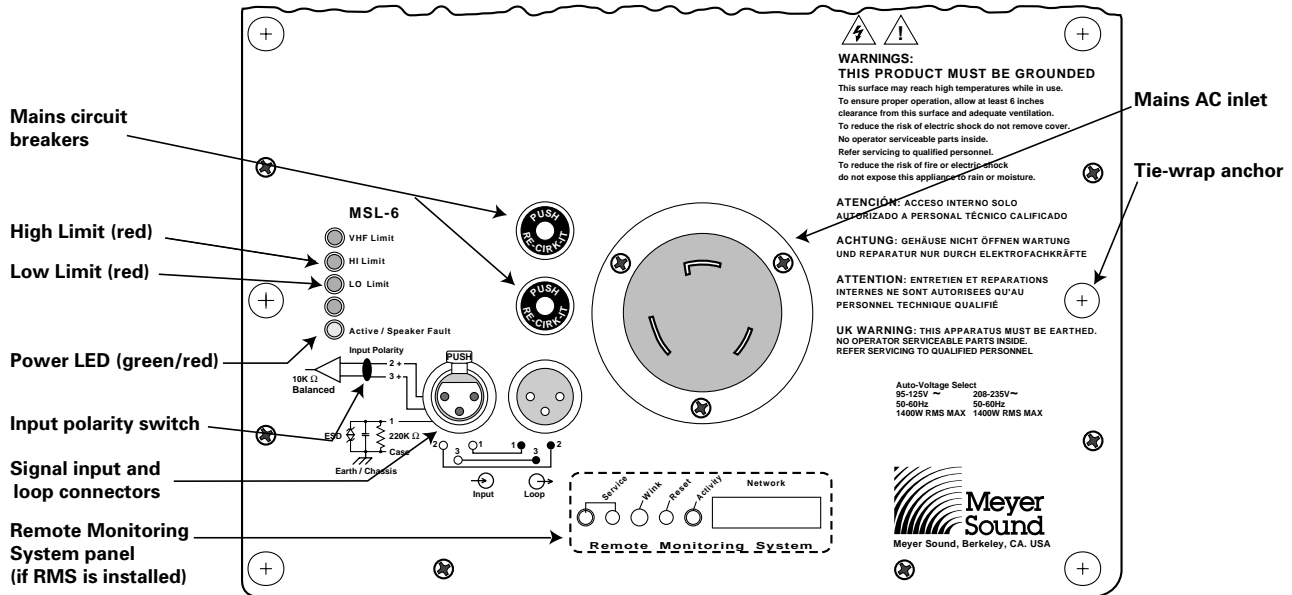

Rear User Panel shown with the optional Remote Monitoring System (RMS) panel

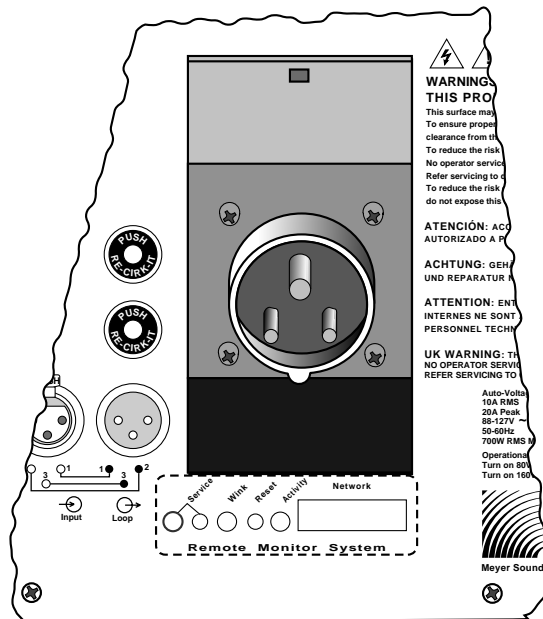

European Rear User Panel with IEC 309 connector

Contact Information

Meyer Sound Laboratories, Inc.
 2832 San Pablo Avenue
 Berkeley, California 94702
 Telephone: 510 - 486 - 1166
 FAX: 510 - 486 - 8356
 E-mail: techsupport@meyersound.com
 http://www.meyersound.com

Meyer Sound Germany Gmbh
 Carl Zeiss Strasse 13
 56751 Polch, Germany
 Telephone: 49.2654.9600.58
 FAX: 49.2654.9600.59

Free Manuals Download Website

<http://myh66.com>

<http://usermanuals.us>

<http://www.somanuals.com>

<http://www.4manuals.cc>

<http://www.manual-lib.com>

<http://www.404manual.com>

<http://www.luxmanual.com>

<http://aubethermostatmanual.com>

Golf course search by state

<http://golfingnear.com>

Email search by domain

<http://emailbydomain.com>

Auto manuals search

<http://auto.somanuals.com>

TV manuals search

<http://tv.somanuals.com>