

500A Series

Loudspeaker System



24
21
18
15
12
9
6
3
0
Inches

Designed for versatility and cost-effectiveness, the 500A Series Loudspeaker System comprises a matched pair of full-frequency 500A or 500AR Loudspeakers in combination with the powerful MS-500A Stereo Integrated Amplifier.

The 500A Series specifications exceed most professional needs. Yet Meyer specifies conservatively and responsibly, in verifiable terms. Even after extended use, the 500A System's performance remains uncompromised.

Easy to install and set up, the System features recessed polarized locking speaker connections, and 3 pin XLR floating ISO-Inputs™ providing 500 volts of isolation in any pin-to-pin or pin-to-chassis combination.



-
- Features**
-
- Professional full-frequency loudspeaker system
 - High power
 - Ultra-low distortion
 - 1200 watt stereo integrated amplifier
 - Versatile and cost-effective
 - Easy installation and set-up
 - Environmental controls
 - Expandable to include matching subwoofers
 - Long-term reliability
-
- Applications**
-
- Discos, cinemas, clubs
 - Churches, schools, auditoriums
 - Musical instrument amplification
 - Control room monitors for audio, video, film
 - PA and AV playback for corporate multimedia

500 AR Loudspeakers atop 502R Bass Enhancers.

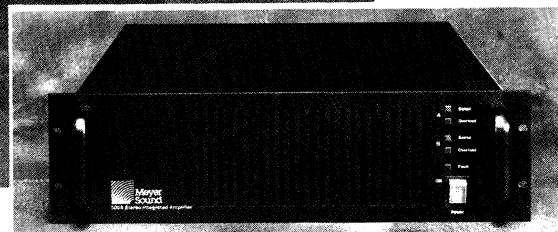

The MS-500A Stereo Integrated Amplifier.

Meyer Sound Laboratories, Inc.
2832 San Pablo Avenue
Berkeley, CA 94702
(415) 486-1166
FAX (415) 486-8356

M E Y E R S O U N D

500A Series Loudspeaker System

The Loudspeaker System delivers high sound pressure levels with very low distortion. Each 500A Series Loudspeaker utilizes a 15" low frequency driver in conjunction with a high-frequency driver mounted on a modified radial horn.

Intended for permanent installations, the 500A Loudspeaker cabinet is repaintable and constructed of plywood-reinforced medium-density fiberboard.

The 500A Loudspeaker also comes in a road version, the 500AR. The 500AR has a more rugged cabinet, constructed of multiple-ply cross-laminated hardwood, with heavy-duty recessed grips and a metal grill. The 500AR's black textured finish will withstand hard use. Both have built-in rigging blocks, and they share the same dimensions and performance specifications.

MS-500A Stereo Integrated Amplifier

The professional-quality MS-500A Stereo Integrated Amplifier contains complementary phase equalization and control electronics, with sophisticated driver and amplifier protection circuitry. The fully regulated power supply delivers 600 watts per channel continuously into 4 ohms. The

MS-500A Amplifier includes environmental controls to match the system to various room conditions. The amplifier is capable of powering a total of four 500A Series Loudspeakers, or two Loudspeakers and a complementary pair of optional 501, 502R, or 518R Bass Enhancers.

Bass Enhancer Options for the 500A Series Models 501, 502R, 518R

The optional 500A Series Bass Enhancers—501, 502R, 518R—offer highly linear response with extremely low distortion, with high continuous and peak power handling.

Adding Bass Enhancers to the system requires adjusting the Lo Cut control on the MS-500A (see facing page) for flat frequency response. While the 500A or 500AR loudspeakers continue to operate at full range, the Bass Enhancers allow for increased low frequency efficiency and higher sound pressure levels across the whole spectrum.

Each Enhancer consists of a single MS-18 18-inch low frequency cone driver mounted in a vented enclosure with passive crossover. The MS-18 cone driver, damped against resonance and treated to resist moisture, employs fluid cooling and back-venting of both the voice coil gap and the pole piece. Meyer Sound components have featured the MS-18 since the company began operations in 1979.

Models 501 and 502R, while their cabinets present different aspect ratios, have the same internal volume and provide

identical performance. Designed for permanent installation, the 501 has a very shallow cabinet depth (equal to that of the 500A Loudspeaker) to ease mounting requirements. The 502R, designed for portable use, features a ruggedized cabinet dimensioned for ease of handling.

The 501 and 502R offer great flexibility in placement since they reproduce only very low frequencies. When augmenting a flown full-range 500A System, for example, they may be placed on the floor below the full-range cabinets. In both the 501 and the 502R, the crossover frequency is 90 Hz, with a -20dB point of 300 Hz.

The 518R, also intended for portable use, offers maximum power in a very compact package. The 518R relies upon direct acoustical coupling with the full-range loudspeaker that it augments. The crossover frequency is 125 Hz with a -20dB frequency of 1,000 Hz, so it reproduces frequencies that provide directionality clues. As such, the 518R must be placed directly beside or under its complementary full-range 500A Series Loudspeaker.



500 AR Loudspeaker atop 518R Bass Enhancer.

MS-500A Panel Description

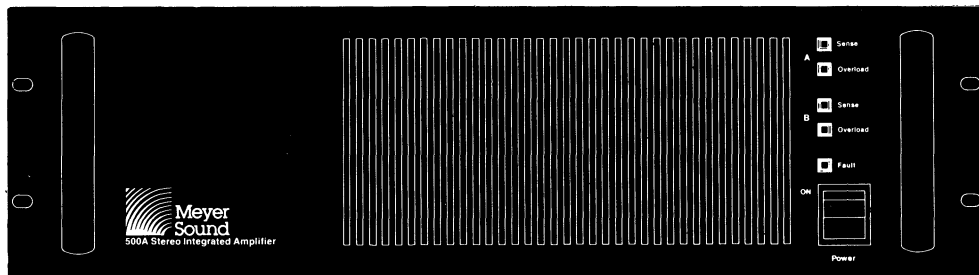

Front Panel

Air Intake—The MS-500A Amplifier is fan cooled, the flow of air being from the front to the rear of the chassis. The air intake is backed by a foam dust filter which may be removed for cleaning.

Power Switch—A green rocker switch which illuminates when engaged.

Carrying Handles—Heavy-duty contoured aluminum handles for transporting convenience.

Fault Indicator—A multipurpose red LED which lights when a potentially damaging fault condition is sensed by the protection circuitry and the amplifier has shut down to protect itself.

Sense Indicators—Green LED signal-presence indicators monitor the amplifier section of the unit, flickering at low input signal levels and glowing steadily at moderate or high levels.

Overload Indicators—Red LED indicators activate when the the operating limit of the 500A System is approached. They will flash intermittently on program peaks. Continuous illumination indicates system is being overdriven.

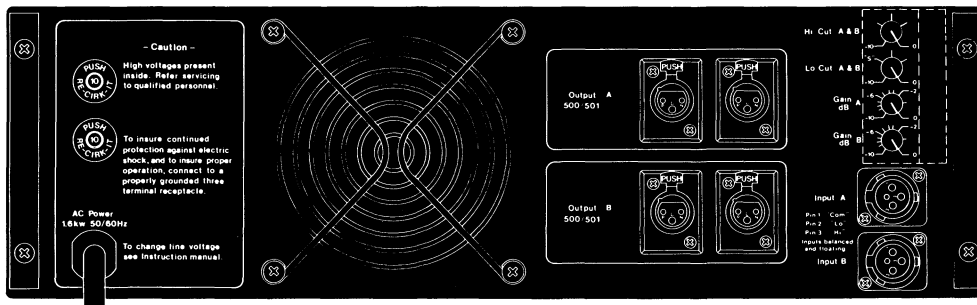

Rear Panel

Protective Standoffs—Rugged plastic supports protect the MS-500A Amplifier rear panel controls when the unit is placed on its back.

Primary Circuit Breakers—Resettable circuit breakers provide primary system protection.

Cooling Fan—The cooling fan is of all-metal construction and is sealed against dust.

Output Connectors—Three pin AXR-type receptacles are provided for the connection of 500A Series Loudspeakers and/or 501, 502R or 518R Bass Enhancers, two per channel.

Signal Input Connectors—XLR-type balanced floating signal inputs (pin 3 hot) will accept balanced or unbalanced inputs, thus interfacing easily with either professional or semi-professional systems.

Security Cover—Removeable metal cover discourages tampering with user-adjustable Hi Cut, Lo Cut and Gain controls.

Gain Controls—Single-turn calibration potentiometers with a gain adjustment range of 10 dB (with 1 dB markings) are used to calibrate the 500A System for the nominal operating level of the signal source.

Hi Cut Environmental Control—A single-turn equalization control affecting the high-frequency response of both channels of the system. Response of the equalization circuit varies from 3 dB per octave at moderate settings to 6 dB per octave at maximum cut; the turnover (−3 dB) frequency at maximum cut is 5kHz. The High Cut control is used to set broad high-frequency equalization characteristics such as "room curves" and SMPTE theatre equalization curves.

Lo Cut Environmental Control—A single-turn equalization control affecting the low-frequency response of both channels of the system. At moderate settings, the Lo Cut circuit exhibits a shelving response with 3 dB per octave roll-off; at extreme cut, it introduces a 6 dB per octave highpass function. Turnover frequency is approximately 500 Hz. The Lo Cut control is used to adjust the system response for various boundary conditions.

Environmental Controls Frequency Response

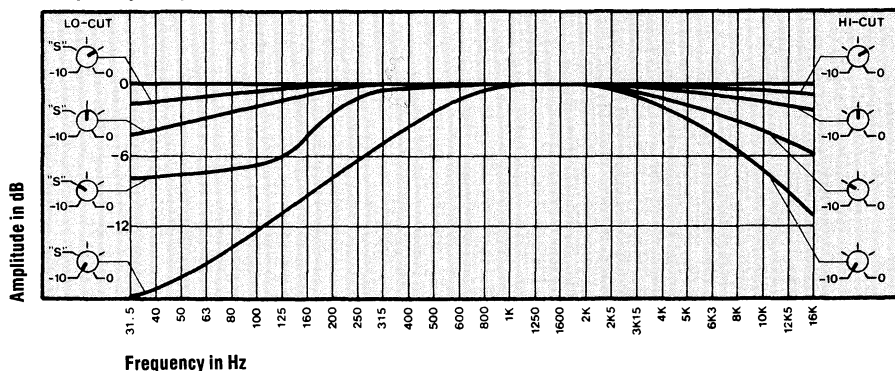

500A Series Specifications

500A Series Loudspeaker System

Frequency Response ¹	30 Hz to 16 kHz dB (Half-space)	
	40 Hz to 16 kHz ± 3 dB (Free field)	
Sensitivity	110 dB SPL – 1v RMS, 0 dBv gain, sine wave sweep	
Maximum SPL (Half-space)	Single Speaker	“Monoblock” Configuration ²
Peak pressure (program)	130 dB SPL	135 dB SPL
10 sec. tone burst	120 dB SPL	125 dB SPL
	150 Hz to 10 kHz	40 Hz to 10 kHz
Continuous sine wave	110 dB SPL	120 dB SPL
	100 Hz to 16 kHz	35 Hz to 16 kHz
High Frequency Coverage ¹⁻³		
Horizontal	90 degrees	
Vertical	40 degrees	
Relative Delay ⁴	± .0001 sec. 150 Hz to 16 kHz	
System Noise (500A Loudspeaker & Amplifier)	Less than 30 dBA SPL	

500A/500AR Loudspeaker

Driver Complement	(1) MS-15 low frequency cone driver (1) MS-1402 high-frequency horn driver on modified radial horn
Crossover	Passive
Highpass slope	12 dB per octave
Lowpass slope	6 dB per octave
Acoustical Crossover Frequency	1000 Hz
Enclosure	500A 3.75 cu. ft. vented. Plywood-braced medium-density fiberboard construction 500AR 3.75 cu. ft. vented. Multilaminate hardwood with perforated steel grill
Finish	Flat black textured, paintable lacquer coating
Connector	Male three-pin AXR-type, recessed, polarized, locking
Cable	10-meter, 14-gauge, two-conductor, 3/8" OD
Physical dimensions	20" W × 32" H × 14" D
Shipping Weight	110 lbs.

501 Bass Enhancer

Frequency Response ¹	30 to 90 Hz ± 4 dB (–20 dB at 300 Hz)
Maximum SPL (Quarter space)	
Continuous	120 dB SPL
Peak	130 dB SPL
Driver Complement	(1) MS-18 cone driver
Acoustical Crossover Frequency	100 Hz
Enclosure	7.5 cu. ft. vented. Plywood-braced medium-density fiberboard construction
Finish	Flat black textured, paintable lacquer coating
Connector	Male three-pin AXR-type, recessed, polarized, locking
Physical Dimensions	32" W × 40" H × 14" D
Shipping Weight	150 lbs.

502R Bass Enhancer

Frequency Response ¹	30 to 90 Hz ± 4 dB (–20 dB at 300 Hz)
Maximum SPL ²	
Continuous	120 dB
Peak	130 dB
Driver Complement	(1) MS-18 18-inch cone driver
Acoustical Crossover Frequency	100 Hz
Enclosure	7.5 cu. ft. vented. Multilaminate hardwood with perforated steel grill

Finish	Black textured
Connector	Male three-pin AXR-type
Physical Dimensions	26" W×32" H×20" D
Shipping Weight	150 lbs.
518R Bass Enhancer	
Frequency Response	40 to 125 Hz ±3 dB (−20 dB at 1000 Hz)
Maximum SPL ²	
Continuous	120 dB
Peak	125 dB
Driver Complement	(1) MS-18 low-frequency cone driver
Acoustical Crossover Frequency	125 Hz
Enclosure	3.75 cu. ft. vented. Multilaminate hardwood with perforated steel grill
Finish	Black textured
Connector	Male 3-pin AXR-type
Physical Dimensions	20" W×32" H×14" D
Shipping Weight	90 lbs.
MS-500A Stereo Integrated Amplifier	
Signal Inputs	
Type	Floating balanced, AC coupled, pin 3 hot
Impedance	5k ohms unbalanced (pins 1&3, pins 1&2) 10k ohms balanced (pins 2&3)
Maximum common-mode voltage	500 volts peak
Common-mode rejection ratio	
100 Hz	80 dB
1 kHz	70 dB
10 kHz	60 dB
Damping Factor	Immeasurable, estimated at 100,000
Power Output ²⁻⁵	1200 watts sine wave average power output, total both channels, floating. (72v and 18A peak per channel)
Total Harmonic Distortion	Less than .1%
Crosstalk	70 dB A weighted
Dynamic Range	Greater than 100 dB
Driver Protection	Peak limiting, sliding high and low frequency filters, long-term power integrator, DC protection
Amplifier Protection	Protects against shorted output, over temperature operation, incorrect AC voltage selection
Indicators and Controls	(See diagram)
Cooling System	
Fan noise level ⁶	35 dBA, front; 45 dBA, rear of chassis
Connectors	
Input	Three-pin XLR-type female, locking
Output	Three-pin AXR-type female, locking (2 per channel)
Power Requirements	120/240V AC, 50/60 Hz (internally switchable)
Power Consumption	1600 watts maximum. (2400VA/10 sec.; 1200VA/8hr.; 350VA idle)
Operating Temperature Range	0 to 45 degrees Centigrade
Physical Dimensions	19" W×5.25" H×16" D
Shipping Weight	60 lbs.

Notes:
Unless otherwise noted, all measurements made at one meter on axis of the high frequency horn of one 500A Loudspeaker driven by one channel of the MS-500A Stereo Integrated Amplifier.

Note 1:
Measured in third-octave bands with pink noise output.

Note 2:
Two 500A Loudspeakers with two 501 Bass Enhancers grouped together and driven by both channels of the Stereo Integrated Amplifier.

Note 3:
Angle measured between −6 dB points, 500 Hz to 8 kHz bandwidth.

Note 4:
Measured with a sine wave sweep, half-space loading, delay response averaged on an octave band basis.

Note 5:
Electronic protection limits power output to speakers to maintain safe operating parameters.

Note 6:
Measurements made at one meter, fan at low speed, normal operating temperature. For high speed operation, add 10 dB to noise figures.

500A Loudspeaker Polar Patterns

- 500 Hz
- - - 1kHz
- · - · 2kHz
- · - · 4kHz
- · - · 8kHz
- 16kHz

Measured at 1 Meter in Free Field, Composite Octave Bands

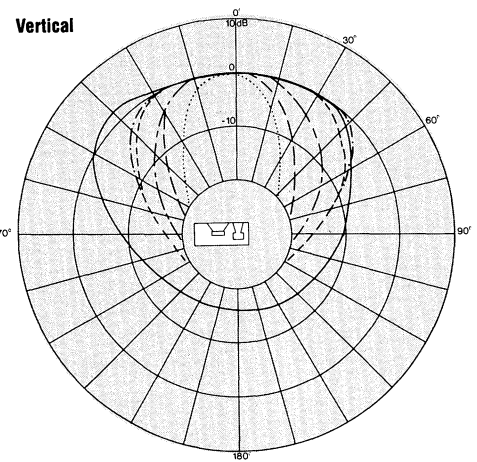
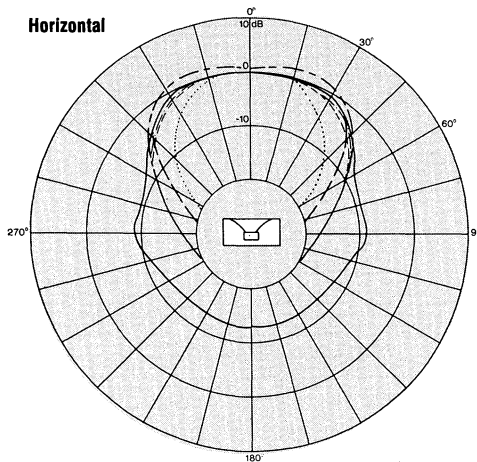

Frequency Response

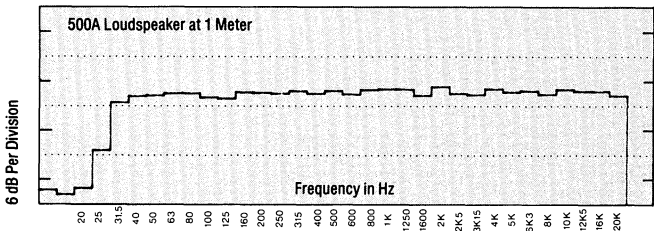

Relative Delay Response

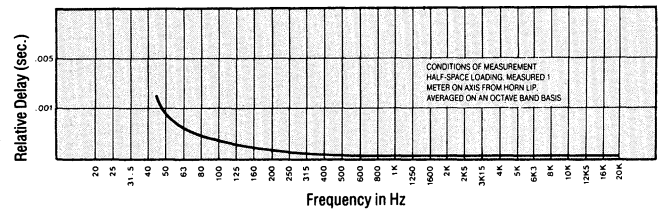

Typical Distortion Figures 500A Series Loudspeaker System at High SPL

Conditions of measurement: quarter-space loading, measured 1 meter on axis.

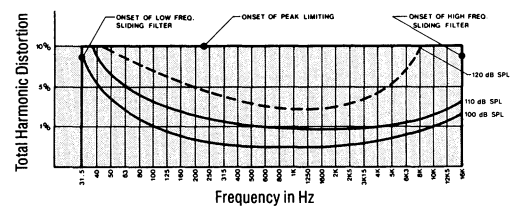
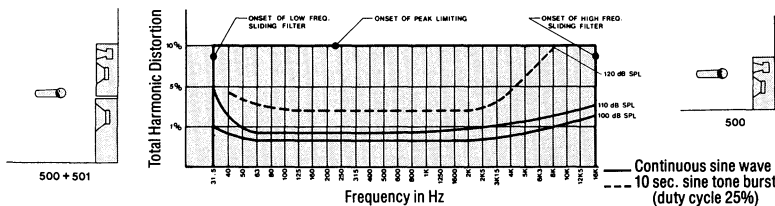

Dimensional Diagram

Both the 500A and 501 cabinets contain recessed hand grips for ease of handling as well as internally mounted 3/4" plywood rigging blocks to facilitate permanent installation. Suggested rigging points are indicated to provide various degrees of cabinet tilt.

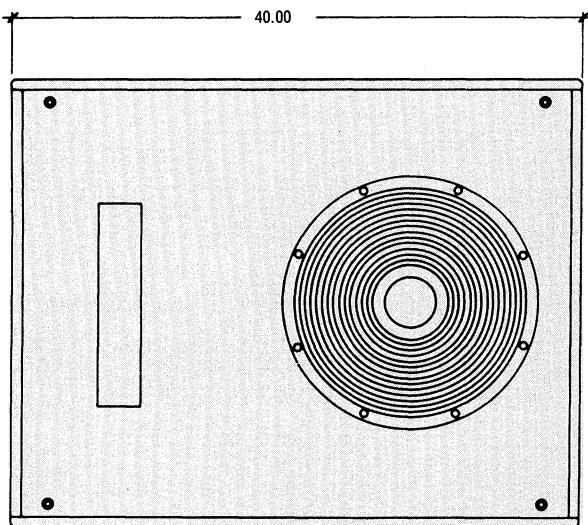

501 Subwoofer

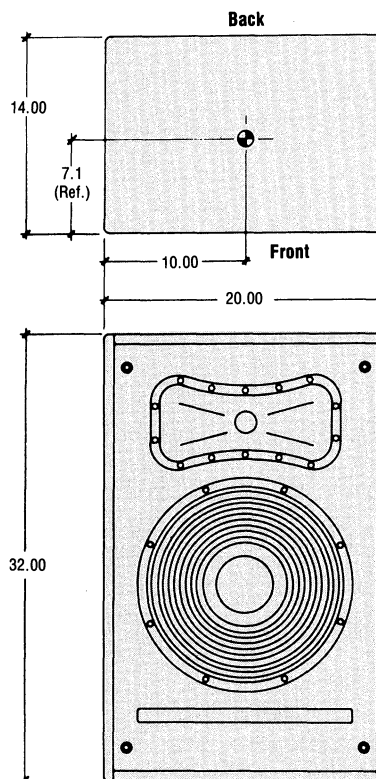

500A Loudspeaker

NOTES:

- ① Dimensioned dots suggest possible rigging positions for 500A loudspeaker.
- Center of gravity ± .40 inches

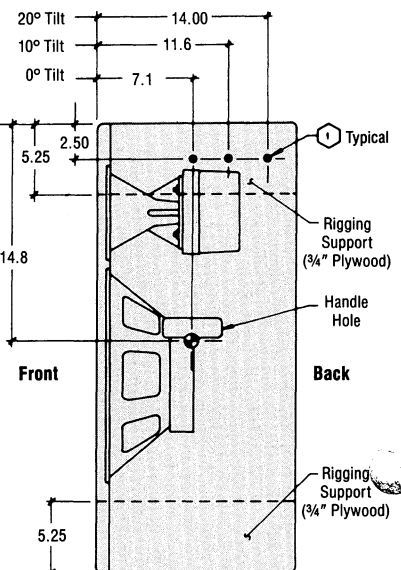

The System

The system shall consist of a pair of two-way full-frequency loudspeakers in combination with a single complementary electronics package consisting of a 600 watt per channel stereo amplifier, loudspeaker equalization and control electronics, and driver and amplifier protection circuitry. The system shall meet the following criteria: frequency response, 40 Hz to 16 kHz, ± 3 dB, measured free field in third octave bands with pink noise input at one meter on axis of the high frequency horn. Maximum SPL (half-space) of the system when combined in a "mono-block" configuration with two optional bass enhancers (each containing a single 18" cone driver) shall be 120 dB SPL, continuous sine wave, 35 Hz to 16 kHz. System sensitivity of a single loudspeaker shall be 110 dB SPL measured with a sine wave sweep, 1 volt RMS input, 0 dB gain. Coverage of any one loudspeaker from 500 Hz to 8 kHz shall be 90 degrees horizontal by 40 degrees vertical (± 10 degrees) at the -6 dB points. System noise measured at one meter in front of one loudspeaker shall be no more than 30 dBA SPL.

The system shall be the Meyer Sound 500A Series Loudspeaker System consisting of two 500A or 500AR Loudspeakers and the MS-500A Stereo Integrated Amplifier. Optional bass enhancers shall be the Meyer Sound 501, 502R or 518R Bass Enhancers.

The Loudspeaker

Each loudspeaker shall contain a 15" low frequency cone driver and a high frequency horn driver on a modified radial horn mounted in a 3.75 cu. ft. vented cabinet measuring 20"W \times 32"H \times 14"D, and tuned to 40 Hz. The cone driver shall consist of a water repellant, silicone impregnated cone with an 80 oz., 13,500 gauss ($\pm 5\%$) ferrite magnet and shall be capable of handling 800 watts of peak power as well as 200 watts of continuous sine wave power over an 8 hour period. The voice coil shall be 3" in diameter, oil cooled, rear vented and constructed of solid copper ribbon on an aluminum former. The driver shall weigh 19 lbs. (± 1 lb.), have a maximum peak-to-peak displacement of 1" and a nominal impedance of 8 ohms. The high frequency horn driver shall contain a 42.2 oz. 17,000 gauss ($\pm 5\%$) magnet and be capable of handling 350 watts peak power as well as 60 watts of continuous sine wave power over an 8 hour period. The voice coil shall be 2.8" in diameter and constructed of edgewound copper-clad aluminum ribbon on a Capton™ (Dupont)

former. The driver shall weigh 11 lbs. 4 oz. (± 8 oz.), have a throat diameter of 1.4", a maximum peak-to-peak displacement of .025" and a nominal impedance of 16 ohms. The high frequency horn shall be a modified radial design and constructed of self-damped urethane. The loudspeaker crossover shall be passive with 12 dB per octave highpass and 6 dB per octave lowpass slopes and shall have an acoustical crossover frequency of 1000 Hz. Speaker connection to the amplifier shall be via male three-pin AXR-type polarized locking connectors that shall be recessed into the rear of the loudspeaker cabinet. The cabinet shall have a weight of no more than 110 lbs.

The loudspeakers shall be the Meyer Sound 500A or 500AR Loudspeakers. Other speakers shall be considered for equivalency provided that data be submitted from a recognized independent test laboratory verifying that the above performance specifications are met.

The Bass Enhancer

The optional companion bass enhancer to the system shall have a frequency response of 30 to 90 Hz or 40 to 125 Hz. Maximum SPL with quarter space loading shall be 125 or 130 dB SPL peak and 120 dB SPL continuous, 40 Hz to 90 Hz. The bass enhancer shall contain a single 18" low frequency cone driver mounted in a vented cabinet. The cone driver shall consist of a water repellant, silicone impregnated cone with an 80 oz., 13,500 gauss ($\pm 5\%$) ferrite magnet and shall be capable of handling 800 watts of peak power as well as 200 watts of continuous sine wave power over an 8 hour period. The voice coil shall be 3" in diameter, oil cooled, rear vented and constructed of solid copper ribbon on an aluminum former. The driver shall weigh 21 lbs., 8 oz. (± 1 lb.), have a maximum peak-to-peak displacement of 1" and a nominal impedance of 8 ohms. The bass enhancer shall have an acoustical crossover frequency of 100 Hz and contain an internally mounted low pass filter (-20 dB at 300 Hz), thus eliminating the need for an external crossover. Connection to the amplifier shall be via male three-pin AXR-type polarized locking connectors that shall be recessed into the rear of the loudspeaker cabinet. The cabinet shall have a weight of no more than 150 lbs.

The optional companion bass enhancer shall be the Meyer Sound 501, 502R or 518R Bass Enhancer. Other speakers shall be considered for equivalency provided that data be submitted from a recognized independent test laboratory verifying that the above performance specifications are met.

The Stereo Integrated Amplifier

The electronics package for the system shall integrate stereo complementary-phase equalization and driver protection circuitry for the companion loudspeakers with a high performance stereo power amplifier in a single rack-mountable all-steel chassis measuring 19"W×5.25"H×16"D. It shall contain a power supply capable of operating from a 120/240V AC, 50/60 Hz line. Electronic control circuitry shall provide protection for the system against output DC offsets, excessive continuous power, output shorts and overheating. The input stage to each channel shall constitute a three-port floating balanced AC coupled signal input system, allow a full 500 volts of common-mode isolation and accommodate a wide range of input pin connections while maintaining unity gain. Input impedance shall be 5K ohms unbalanced and 10k ohms balanced. Input connectors shall be locking three-pin female XLR-type (pin 3 hot) and output connectors shall be locking three-pin female AXR-type, two per channel. The common mode rejection ratio shall be 80 DB at 100 Hz, 70 dB at 1 kHz and 60 dB at 10 kHz. The input shall eliminate power frequency hum injection by floating above chassis, ground, and common. The differential input stage to each channel shall be followed by a rear-mounted variable attenuator which functions as the channel gain control, has a 10 dB range marked off in 1 dB increments and calibrates the system to the source equipment's operating level. The gain control shall be buffered by a peaking circuit tuned for a center frequency of 40 Hz. High-pass and low-pass environment complementary equalization circuits shall be included with rear panel controls that affect both channels simultaneously. The high-pass section shall be used to compensate for various boundary conditions and shall exhibit a response varying from a gentle rolloff at minimum settings through a shelving response at intermediate settings to a 6 dB per octave rolloff at maximum setting. The turnover (-3 dB) frequency at maximum cut shall be 500 Hz. The lowpass section shall exhibit a gentle variable rolloff which, at maximum cut, introduces a 6 dB per octave lowpass characteristic with a turnover (-3 dB) frequency of 5 kHz. A high frequency filter shall be included to protect the loudspeaker from overexcursion on high power program peaks containing large amounts of high-frequency information. At levels up to 3 dB below the clip-

ping point, the circuit shall act as a peaking equalizer with a center frequency of 16 kHz. A low frequency sliding filter shall be included to protect the low frequency driver from excessive excursion at high power levels. At low to moderate amplifier power levels, the filter's turnover (-3) frequency shall be 25 Hz. At high power levels the filter's tuning shall slide upward to a maximum of 300 Hz and thereafter act as a peak limiter. Whenever the sliding filters are activated, front panel indicator lights shall flash. Six fixed-frequency peak/dip complementary-phase equalization circuits shall be incorporated for broadband equalization of the loudspeakers. A long term integrating circuit shall be included to provide advance warning via front panel LED indicators of an impending shutdown by the amplifier's overload protection circuitry. The power amplifier section of the electronics package shall be capable of producing 1200 watts sine wave average power output, both channels driven, floating, for a maximum of 10 seconds. The amplifier's bandwidth shall be at least 100 kHz, with THD of less than .01% (20 Hz to 20 kHz) and shall have a dynamic range in excess of 100 dB. The damping factor shall be immeasurably high. Crosstalk shall be 70 dB between channels. The signal path shall be complementary-symmetry throughout and AC coupled. The differential input stage shall include a soft-clipping circuit to simulate tube-type clipping characteristics. An error-correction amplifier system shall be incorporated to linearize the junction between a complementary-symmetry bipolar driver stage and output MOSFETs to reduce distortion. The power MOSFETs shall be mounted on an aluminum tunnel heatsink which shall be designed to float from chassis ground and shall be mounted on flanges made of high-temperature polycarbonate material. The electronics package shall be forced-air cooled by an automatic two speed all-metal fan which is protected against dust and designed to vent air from the front to the rear of the unit. Power supplies shall be ±80VDC and ±15VDC, fully regulated and soft-starting.

The stereo integrated amplifier shall be the Meyer Sound MS-500A Stereo Integrated Amplifier.

Meyer Sound Laboratories has devoted itself to designing, manufacturing, and refining components that deliver superb sonic reproduction. Every part of every component is designed and built to exacting specifications and undergoes rigorous, comprehensive testing in the laboratories.

Research remains an integral, driving force behind all production. Meyer strives for sound quality that is predictable and neutral over an extended lifetime and across an extended range.

**Sound
engineering
for the art
and science
of sound.**



Meyer Sound Laboratories, Inc.
2832 San Pablo Avenue
Berkeley, CA 94702
(415) 486-1166
FAX (415) 486-8356

Free Manuals Download Website

<http://myh66.com>

<http://usermanuals.us>

<http://www.somanuals.com>

<http://www.4manuals.cc>

<http://www.manual-lib.com>

<http://www.404manual.com>

<http://www.luxmanual.com>

<http://aubethermostatmanual.com>

Golf course search by state

<http://golfingnear.com>

Email search by domain

<http://emailbydomain.com>

Auto manuals search

<http://auto.somanuals.com>

TV manuals search

<http://tv.somanuals.com>