



Measuring Monkeys!™



INSTRUCTION GUIDE

LER 1880

 **WARNING:**
CHOKING HAZARD - Small parts.
Not for children under 3 years.



LER 1880 — Measuring Monkeys™

www.learningresources.com

© Learning Resources, Inc., Vernon Hills, IL 60061 (USA)
Download from www.Somanuals.com. All Manuals Search And Download.

Measuring Monkeys™

Contents

- Two-sided spinner
- Spinner center
- Two-piece plastic spinner arrow
- 10 banana pegs
- Treetop and base
- Tree trunk with four sliding monkeys

Object of the Game

Be the first player to move a monkey to the 12" mark at the top of the tree.

Set Up

- Fold the tree trunk. Insert it into the base. Pop the treetop onto the trunk as shown.
- Make sure each monkey slides easily from the top to the bottom of the tree. To adjust the tension on a monkey: unfold the tree, hold both the front and the back of the monkey, and gently pull on the circular plastic back to loosen.
- Pop the two-piece plastic spinner arrow into the cardboard spinner center as shown.
- Choose a level of play. Level 1 uses only 1" increments and uses the green side of the spinner. Level 2 uses $\frac{1}{4}$ " increments and the red side of the spinner. Assemble the spinner so that the arrow faces the appropriately colored side.
- Choose the side of the tree that is facing you and place a banana peg in the lowest red hole. Hook the monkey's hand over the banana peg. Begin playing on this side of the tree. When the tree is turned, you will move the new monkey that is facing you.

*Note: Each hole on the tree is color-coded according to the unit of measurement located next to it. A red hole is located next to each full inch. A green hole is located next to each measurement ending in $\frac{1}{4}$ inch. A blue hole is located next to each measurement ending in $\frac{1}{2}$ inch. A yellow hole is located next to each measurement ending in $\frac{3}{4}$ inch.

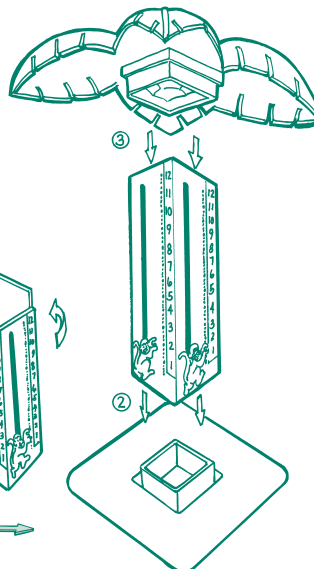

How to Play:

- On your turn, spin and follow the directions.
- If you spin a measurement move your monkey on the tree. (You will need to use a second banana peg to do this.) Remove your monkey from the old peg so that you can clearly see all the increments on the tape measure and the holes next to them. Measure up or down from the old peg, adding or subtracting the number of inches shown on the spinner. Place the new banana peg in the appropriate hole for the new measurement. Then remove the old peg to use on your next turn. Attach your monkey to the new banana peg.
- If you spin "**turn the tree**," turn the tree in the direction indicated so that the next side of the tree is facing you. Every player now has a new monkey to move. Spin again and move your new monkey.
- If you spin "**dropped the banana**," pull out your monkey's banana peg and let your monkey fall down to the bottom of the tree. Place the banana in the lowest hole and hook your monkey's hand around it.
- To win, be the first player to get a monkey's hand to the 12" mark at the top of the tree.

Free Manuals Download Website

<http://myh66.com>

<http://usermanuals.us>

<http://www.somanuals.com>

<http://www.4manuals.cc>

<http://www.manual-lib.com>

<http://www.404manual.com>

<http://www.luxmanual.com>

<http://aubethermostatmanual.com>

Golf course search by state

<http://golfingnear.com>

Email search by domain

<http://emailbydomain.com>

Auto manuals search

<http://auto.somanuals.com>

TV manuals search

<http://tv.somanuals.com>