



Leica SP2600

Ultramilling attachment

Supplementary instruction manual Leica SP2600

To be used only in conjunction
with instruction manual Leica SM2500 .

V1.2 English – 07/2002

Always keep this manual near the instrument.
Read carefully prior to operating the instrument.

Leica
MICROSYSTEMS

NOTE

The information, numerical data, notes and value judgments contained in this manual represent the current state of scientific knowledge and state-of-the-art technology as we understand it following thorough investigation in this field.

We are under no obligation to update the present manual according to the latest technical developments, nor to provide our customers with additional copies, updates etc. of this manual.

For erroneous statements, drawings, technical illustrations etc. contained in this manual we exclude liability as far as permissible according to the national legal system applicable in each individual case. In particular, no liability whatsoever is accepted for any financial loss or consequential damage caused by or related to compliance with statements or other information in this manual.

Statements, drawings, illustrations and other information as regards contents or technical details of the present manual are not to be considered as warranted characteristics of our products.

These are determined only by the contract provisions agreed between ourselves and our customers.

Leica reserves the right to change technical specifications as well as manufacturing processes without prior notice. Only in this way is it possible to continuously improve the technology and manufacturing techniques used in our products. This document is protected under copyright laws. Any copyrights of this document are retained by Leica Microsystems Nussloch GmbH.

Any reproduction of text and illustrations (or of any parts thereof) by means of print, photocopy, microfiche, web cam or other methods – including any electronic systems and media – requires express prior permission in writing by Leica Microsystems Nussloch GmbH.

For the instrument serial number and year of manufacture, please refer to the name plate at the back of the instrument.

© Leica Microsystems Nussloch GmbH

Published by:

Leica Microsystems Nussloch GmbH

Heidelberger Str. 17 - 19

D-69226 Nussloch

Germany

Telephone: +49 (0)6224 143-0

Facsimile: +49 (0)6224 143-200

Internet: <http://www.histo-solutions.com>

Table of contents

1.	Important information	6
1.1	Symbols in the text and their meaning	6
1.2	Designated use	6
1.3	Information on this instruction manual	7
2.	Safety	8
2.1	Safety regulations	8
2.2	Built-in safety devices	9
2.3	Safety instructions	10
3.	Technical Data	13
4.	Installation	14
4.1	Overview - Leica SP2600 Ultramilling attachment / basic instrument Leica SM2500 - instrument parts / functions	14
4.2	Leica SP2600 standard delivery	15
4.3	Site requirements	15
4.4	Unpacking, transport, installation	15
4.5	Installing the Leica SP2600 ultramilling attachment	16
4.6	Connecting the vacuum cleaner	17
4.7	Installing additional accessories	18
5.	Operation	19
5.1	Overview of chapter 5 'Operation'	19
5.2	Adjusting the pre-millers in the calibrating device	20
5.3	Adjusting the finishing millers in the calibrating device	25
5.4	Specimen holder systems - how to combine individual components	29
5.5	Clamping specimen	30
5.5.1	Installing the base plates in the basic instrument	30
5.5.2	Clamping the specimen holders in the base plate with dove tail guide	30
5.5.3	Clamping the vacuum stages on/in the base plates	31
5.5.4	Connecting the vacuum pump / placing specimens onto the vacuum stages	32
5.6	Preparatory steps prior to the milling procedure	34
5.7	Pre-milling	36
5.7.1	Perspective view of the pre-milling procedure	38
5.8	Finishing milling	40
5.8.1	Perspective view of the finishing milling procedure	42
5.9	Switching the instrument off (switching off the control unit	43

6.	Troubleshooting	44
7.	Cleaning, disinfection and maintenance	45
7.1	Cleaning and disinfection	45
7.2	Maintenance	46
7.2.1	Resharpener the millers	46
7.2.2	Replacing the light bulb in the calibration device	47
8.	Overview - accessories	48
8.1	Miller holders and millers	48
8.2	Base plates for specimen holders and vacuum stage adapters	48
8.3	Specimen holders	48
8.4	Vacuum stage adapters	48
8.5	Vacuum stages and matching lids / perforated specimen holders	49
8.6	Vacuum pumps	49
8.7	Additional accessories	50
9.	Warranty and service	51

1. Important information

1.1 Symbols in the text and their meaning



Warnings and cautions appear in a grey box and are marked by a warning triangle.

Failure to comply with these warnings/cautions can lead to accidents, bodily injury and damage to instrument and/or accessories.



Notes, i.e. important information for the user, appear in a grey box and are marked by an information sign.

(5)

Figures in brackets refer to item numbers in illustrations or to the illustrations themselves.

ENTER

Function keys that need to be pressed on the control unit are printed in bold and capital letters.

1.2 Designated use



Fig. 1.1

The Leica SP2600 is designated to prepare milled surfaces and thin slices of specimen materials such as plastics and metals as well as of organic materials (such as bones, teeth) in medicine, biology and industry.

The Leica SP2600 ultramilling attachment is an accessory which cannot be operated as a stand-alone device but must be used in conjunction with the Leica SM2500 sliding microtome described in a separate instruction manual.

Specimen surfaces are milled with a rotating spindle, equipped with either a pre- or a finishing miller.

With each sledge stroke, the micrometer feed mechanism of the Leica SM2500 lowers the miller towards the specimen by the feed setting selected.

The Leica SP2600 may be used only in conjunction with accessories and supplementary instruments made by Leica.

If the instrument is used for any other than the designated application, this will be considered an improper use of the product!

1.3 Information on this instruction manual

Instrument type

This supplementary instruction manual must be used together with the Leica SM2500 sliding microtome instruction manual describing the basic instrument Leica SM2500, which is needed to operate the Leica SP2600 ultramilling attachment.

All information provided in this supplementary instruction manual applies only to the instrument type indicated on the title page.

A name plate indicating the instrument type and serial number is attached to the rear of the Leica SP2600 ultramilling device.

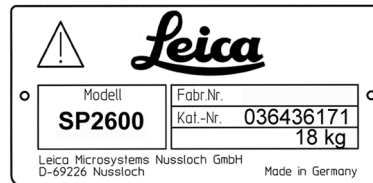

Fig. 1.2

Working with this instruction manual

This supplementary instruction manual contains important instructions and information related to the operating safety and maintenance of the Leica SP2600 ultramilling attachment.

It is an important part of the Leica SP2600 ultramilling attachment.

Prior to setting up and operating the Leica SP2600 together with the Leica SM2500 be sure to read carefully both this supplementary instruction manual as well as the Leica SM2500 instruction manual, with the exception of chapters 5.5.6 - 5.7 of the Leica SM2500 manual. These chapters describe installation of knife holders / knives and sectioning with the Leica SM2500 and are not of importance for operating the Leica SP2600 ultramilling attachment.



If additional requirements on accident prevention and environmental protection exist in the country of operation, this supplementary instruction manual must be supplemented by additional appropriate instructions to ensure compliance with such requirements.

2. Safety

2.1 Safety regulations

This instrument has been built and tested in accordance with the same directives and standards as the Leica SM2500.

For a complete list of the directives and standards applied please refer to chapter 2.1, page 8 of the Leica SM2500 instruction manual.

In order to maintain the SP2600 in a condition compliant with the above directives and standards and to ensure safe operation, the operator must observe the instructions and warnings contained in this supplementary instruction manual as well as in the Leica SM2500 instruction manual.



The Leica SP2600 ultramilling may be operated only in conjunction with the Leica SM2500 sliding microtome!

2.2 Built-in safety devices

The instrument is equipped with the following safety devices:



Fig. 2.1

Plexiglass protective cover

- The miller is equipped with a protective cover made of plexiglass (1). When the cover is moved to the upper limit position (1, Fig. 2.1) the miller is automatically blocked and cannot be started.

For any manipulations in the milling area (such as inserting millers, fine adjustment of specimen height etc.) the protective cover (1, Fig. 2.1) must be in the upper limit position.



Fig. 2.2

To be able to start the miller, the protective cover must be lowered (1, Fig. 2.2).



Never touch the milling spindle while the plexiglass cover is shut, no matter whether the spindle is rotating or not.

Important note on the safety devices built in by the manufacturer:

The safety devices provided by the manufacturer constitute only a basis for accident prevention.

Major responsibility for accident prevention during the use of the instrument rests with the employer who has the operating authority for the instrument and, in addition, with the persons, designated by him, who operate, service and repair the instrument.

To ensure safe and trouble-free operation of the instrument, be sure to comply with all instructions, warning and cautions in this supplementary instruction manual as well as in the Leica SM2500 instruction manual!

2. Safety

2.3 Safety instructions

Safety instructions - transport and installation



Be sure to read and comply with the safety instructions, warnings and cautions in this chapter as well as in chapter 2 of the Leica SM2500 instruction manual, even if you are already familiar with the operation and use of other Leica products.



Be sure to follow the unpacking instructions (attached to the outside of the instrument shipping crate)!

Never remove or modify any of the safety devices installed on the instrument and/or accessories!

Before mounting the ultramilling attachment, make sure the bearing blocks of the microtome supporting the milling attachment and the bearing surfaces of the milling attachment are clean.

Two people are required to place the milling attachment on the bearing blocks from above.

Do not slide the milling attachment onto the bearing blocks to prevent the bearing surfaces of the microtome and milling attachment from getting scratched!

The bearing surfaces must not become damaged under any circumstances!

Caution:

When releasing the lid of the milling attachment (can be lifted and used as a handle) be careful not to get your fingers caught between the lid and the body of the milling attachment!

Safety instructions - general



The Leica SP2600 ultramilling attachment may only be operated in conjunction with the Leica SM2500 sliding microtome.

Prior to working with the Leica SP2600 ultramilling attachment, be sure to read the following instruction manuals:

- The entire Leica SM2500 instruction manual except chapters 5.5.6 through 5.7.
- This supplementary instruction manual Leica SP2600.

The Leica SP2600 ultramilling attachment may only be operated by skilled laboratory personnel. It may only be used for the designated application and operated in accordance with the instructions contained in this supplementary instruction manual and in the Leica SM2500 instruction manual!

Safety instructions - transport and installation



Caution!

Only the vacuum cleaner offered by Leica or other vacuum cleaner brands rated at 230 V / 50 Hz and a maximum power draw of 4 A can be connected directly to the SM2500 control unit (see page 17), and this only in countries where the mains supply is 230 V / 50 Hz!

Otherwise, the vacuum cleaner must be connected directly to mains and operated via the on/off switch of the vacuum cleaner.

Safety instructions - inserting the millers into the holders / working with the calibrating device

Twisted or deformed springs for the miller holders must be exchanged!

When the millers are inserted into the holders the letter 'V' (pre-millers) or 'F' (finishing miller) must be visible for the milling edge to point into the right direction.

Caution:

The gauge contact plate must never hit the milling edge.

This could damage the surface of the contact plate, leading to incorrect measuring results.

Be very careful when drawing the contact plate close to the milling edge.

Always use the magnifier.

Safety instructions - working with the instrument



Never remove or modify any of the safety devices installed on the instrument and/or accessories!

Never touch the milling spindle while the plexiglass cover is shut, no matter whether the spindle is rotating or not.

Always slide the plexiglass cover to the upper position prior to attaching the miller holders to the milling spindle!

Wear protective gloves when working with potentially infectious material!

Always slide the plexiglass cover to the upper position prior to checking the distance between milling edge and specimen surface! - Risk of injury!

Always check the distance between miller cutting edge and specimen surface thoroughly prior to milling!

Under no circumstances may the miller cutting edge be positioned more than a few microns (= selected milling thickness) below the specimen surface when starting the milling procedure.

When spraying alcohol to moisten the specimen surface, remove excess liquid as soon as it starts accumulating.

Do not operate near open flames or near other sources of ignition!

No liquids may enter the interior of the instrument during operation!

2. Safety

Safety instructions - working with the instrument



Do not exceed a milling thickness setting of 5 µm with the following materials: brittle, very ductile materials such as titanium or fiberglass and compound samples containing such materials (such as printed circuit boards).

During milling:

- switch on the vacuum cleaner,
- wear appropriate safety goggles,
- wear appropriate mask (type of mask depends on the material being milled / size of the chips that form during milling).

Goggles and mask prevent milling chips and microdust from entering your eyes and from being inhaled.

Caution - rotating miller:

After switching off the milling spindle (button (37) - chapter. 5.4.11, p. 34 - instruction manual Leica SM2500) the miller continues to rotate for a little while.

When switching off the mains switch on the control unit (see chapter 5.2, p. 21 - Instruction manual Leica SM2500) the milling spindle will rotate briefly. Therefore, never switch off the control unit, while one of your hands is in the rotation zone of the miller.

- Risk of injury!

Never touch the milling spindle while it is rotating and/or while the plexi-glass cover is shut, no matter whether the spindle is rotating or not.

Safety instructions - cleaning disinfection and maintenance



Only authorized service technicians may access the internal components of the instrument for service and repair!

Cleaning detergents appropriate for the ultramilling attachment.

Varnished surfaces:

- mild laboratory detergents (slightly moistened cloth)!

Non-varnished metal parts:

- mild laboratory detergents,
- xylene substitutes (slightly moistened cloth)
- alcohol (slightly moistened cloth).

For disinfection of the instrument and accessories use Leica Cryofect or other commercial disinfectants. - Use all disinfectants according to the manufacturer's instructions.

When disinfecting, wear appropriate goggles and mask as well as protective gloves.

Dispose of potentially infectious specimen material as per the laboratory regulations applicable in the country of operation.

No liquids may enter the interior of the instrument during cleaning, disinfection or maintenance!

Ultramilling attachment

Milling spindle (special design)	type TSAV 60 x 160
Motor, rotation speed selectable in 100-rpm steps	500 to 3.000 rpm
Protective class	I
Pollution degree	2

Dimensions and weight - ultramilling attachment

Dimensions (H x W x D)	300 x 315 x 240 mm
Weight	18 kg

Vacuum cleaner 'Fakir S20'

Nominal voltage	230 V
Nominal frequency	50 Hz
Power draw	max. 4 A



These specifications are supplemented by the specifications contained in the Leica SM2500 instruction manual.

4. Installation

4.1 Overview - Leica SP2600 Ultramilling attachment / basic instrument Leica SM2500 - instrument parts / functions



Fig. 4.1

1. Leica SM2500 - basic instrument (sliding microtome)
 - 1.1 Leica SP2600 - ultramilling attachment
 - 1.2 Carrier for ultramilling attachment SP2600 (when not in use)
 - 1.3 Specimen holder system (not part of standard delivery)
 - 1.4 Carrying handle, black, rear (extendible - not visible in Fig. 4.1)
 - 1.5 Carrying handle, black, front (extendible)
2. Leica SM2500 - control unit
 - 2.1 Control panel
 - 2.2 Emergency stop button
3. Foot switch (not shown in Fig. 4.1 - for details on the foot switch please refer to p. 18, chapter 4.6 of this supplementary instruction manual and to p. 18, chapter 4.5.2 and p. 24, chapter 5.4.1 of the Leica SM2500 manual).

4.2 Leica SP2600 standard delivery

Standard delivery includes:

- 1 Basic instrument Leica SP2600 (Ultramilling attachment)
- 1 Calibrating device with dial gauge for miller adjustment
- 3 Holders, each with two springs, for pre- and finishing millers, one holder delivered attached to the instrument.
- 1 Carrier for Leica SP2600 Ultramilling device when not in use
- 1 Tool set:
 - 1 Allen key, size 2.5, with handle
 - 1 Allen key, size 4.0
 - 1 Allen key, size 4.0 with handle
 - 1 Allen key, size 5.0 with handle
 - 1 Allen key, size, 8.0
- 1 Power cord – type KN 2/5 7,5 V
- 1 Box level
- 1 Plexiglass block, 19 x 33 x 53 mm
- 1 Balance weight, installed in one of the miller holders
- 1 Flat belt
- 1 Dust cover
- 1 Supplementary instruction manual for Leica SP2600, to be used in conjunction with the Leica SM2500 instruction manual
 - German
 - English



Millers and specimen holders are not included in the instrument standard delivery but have to be ordered separately, in accordance with each user's specific application(s). Mounting instructions for all accessories and/or references to the corresponding chapters of the instruction manual Leica SM2500 can be found in chapter 5.6 of this instruction manual.

4.3 Site requirements

For site requirements, please refer to chapter 4.2 of the Leica SM2500 instruction manual.

4.4 Unpacking, transport, installation



Be sure to follow the unpacking instructions (attached to the outside of the instrument shipping crate)!

Never remove or modify any of the safety devices installed on the instrument and/or accessories!



The Leica SP2600 ultramilling attachment is supplied only in conjunction with the Leica SM2500 microtome (Leica SM2500 microtomes already installed at a customer's site must be returned to the manufacturer for upgrading with a Leica SP2600 ultramilling attachment).

For instructions on how to install / set up the Leica SM2500 please refer to chapter 4 of the Leica SM2500 instruction manual.

4. Installation

4.5 Installing the Leica SP2600 ultramilling attachment

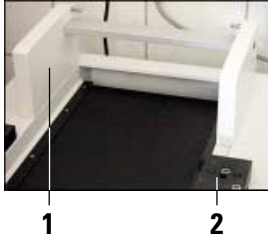

Fig. 4.2



- Place the carrier (1, Fig. 4.2) for the ultramilling attachment (3, Fig. 4.3) on the rear part of the Leica SM2500 microtome fitting the two pins of the carrier into the corresponding bores in the Leica SM2500 microtome.

- Lower the bearing blocks (2) of the microtome as far as they will go (use button (51), chapter 5.4.13, p. 36 - Leica SM2500 manual).
- Prior to placing the ultramilling attachment onto the microtome:



Make sure the bearing blocks of the microtome supporting the milling attachment and the bearing surfaces of the milling attachment are clean.

Two people are required to place the milling attachment on the bearing blocks from above.

Do not slide the milling attachment onto the bearing blocks to prevent the bearing surfaces from getting scratched!

The bearing surfaces must not become damaged under any circumstances!



Fig. 4.3



Caution:

When releasing the lid of the milling attachment (can be lifted and used as a handle) be careful not to get your fingers caught between the lid and the body of the milling attachment!

- Place ultramilling device (3) onto the microtome bearing blocks (two people!).
 - Lift lid (4) of the milling attachment (serves as a handle - see Fig. 4.3).
- Fasten the ultramilling attachment to the microtome with four screws (5) using a size 8 Allen key.
 - Connect the connecting cable of the milling attachment to the control unit (see chapter 4.5.2, page 18 of the Leica SM2500 manual).

4.6 Connecting the vacuum cleaner



Fig. 4.4 1

Milling dust is extracted by a vacuum cleaner, through a nozzle (1) located in the milling area.



230 V / 50 Hz Vacuum cleaners with a power draw of maximum 4 A can be connected directly to the SM2500 control unit and thus be switched on/off via the vacuum cleaner button on the SM2500 control unit.

Installing vacuum cleaners rated at 230 V/ 50 Hz / max. power draw 4 A

- Insert the connection piece of the vacuum cleaner hose into nozzle (1) at the rear of the ultramilling attachment.
- Connect any one of the two adapter cables (both cables are identical) supplied as part of the Leica SM2500 standard delivery into the vacuum cleaner socket at the control unit (see chapter 4.5.2, p. 18 of the Leica SM2500 manual).
- Connect the vacuum cleaner power cord to the socket of the adapter cable.
- Switch on the on/off switch of the vacuum cleaner.
- The vacuum cleaner can now be switched on/off via the vacuum cleaner button on the control unit (button (35), chapter 5.4.11, p. 34 of the Leica SM2500 manual).



Caution!

Only the vacuum cleaner offered by Leica or other vacuum cleaner brands rated at 230 V/ 50 Hz and a maximum power draw of 4 A can be connected directly to the SM2500 control unit, and this only in countries where the mains supply is 230 V / 50 Hz!
Otherwise, the vacuum cleaner must be connected directly to mains and operated via the on/off switch of the vacuum cleaner.

Installing other vacuum cleaners:

- Insert the connection piece of the vacuum cleaner hose into nozzle (1) at the rear of the ultramilling attachment.
- Connect the power cord of the vacuum cleaner to mains.
- Operate the vacuum cleaner via the vacuum cleaner on/off switch.

4. Installation

4.7 Installing additional accessories

- Install further accessories as described in chapters 4.5.2 and 4.5.3, pages 18 and 19 of the Leica SM2500 instruction manual.
- Connect the foot switch.



The foot switch must be connected - otherwise the instrument will not be operational. --> For details on the foot switch, see chapter 4.5.2, p. 18 and chapter 5.4.1, p. 24 of the Leica SM2500 instruction manual.

If working with vacuum stages, also a vacuum pump must be installed - --> see page 33, chapter 5.6.4 of this supplementary instruction manual.

5.1 Overview of chapter 5 'Operation'



Prior to working with the Leica SP2600 ultramilling attachment, be sure to read the following instruction manuals:

- **The entire Leica SM2500 instruction manual except chapters 5.5.6 through 5.7.**
- **This supplementary instruction manual Leica SP2600.**

Chapter 5 of this supplementary instruction manual Leica SP2600 includes the following subchapters:

- 5.1 Overview - chapter 5.
- 5.2 Adjusting the pre-millers in the calibrating device
- 5.3 Adjusting the finishing millers in the calibrating device
- 5.4 Specimen holder systems - how to combine individual components
- 5.5 Clamping specimens
 - 5.5.1 Installing the base plates in the basic instrument
 - 5.5.2 Clamping the specimen holders in the base plate with dovetail guide
 - 5.5.3 Clamping the vacuum stages on/in the base plates
 - 5.5.4 Connecting the vacuum pump/placing specimens onto the vacuum stages
- 5.6 Preparatory steps prior to the milling procedure
- 5.7 Pre-milling
 - 5.7.1 Perspective view of the pre-milling procedure
- 5.8 Finishing milling
 - 5.8.1 Perspective view of the finishing milling procedure
- 5.9 Switching the instrument off (switching off the control unit).

Initial operation:

The first time you operate the instrument, we recommend you work through the above subchapters, in numerical order as listed.

Pay particular attention to the safety instructions..

5. Operation

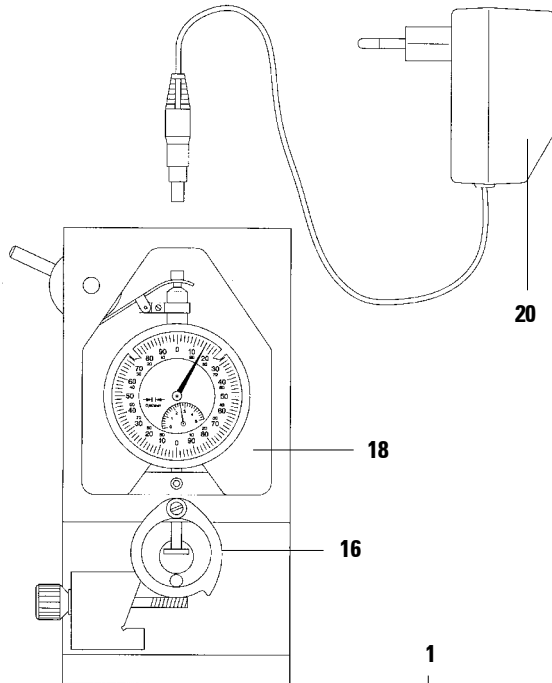

Fig. 5.1

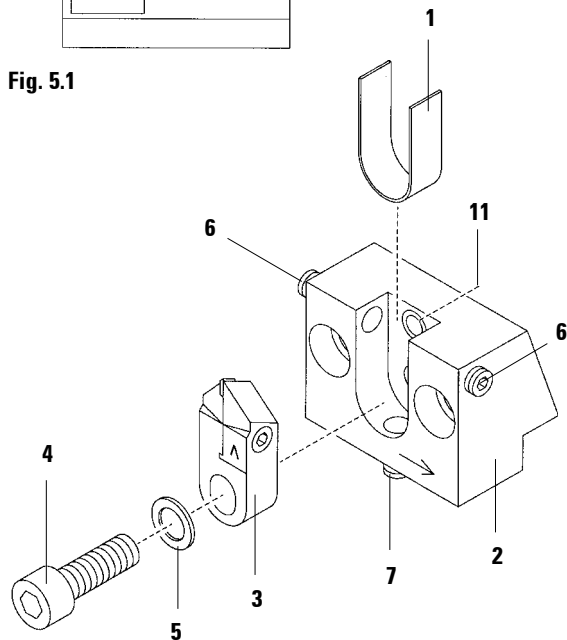

Fig. 5.2

5.2 Adjusting the pre-millers in the calibrating device

Preparatory steps

- Connect mains power supply (20) to miller calibration device (18).
 - Connect mains power supply (20) to mains: the light bulb is switched on.
 - Place magnifier (16) onto calibration device.
 - Loosen regulating screws (6), (7) and (11) in miller holder (2) until they are flush with the inner surfaces of the miller holder.
- If the screws protrude from the inner surfaces of the miller holder (2), spring (1) and miller (3) cannot be inserted into the correct position.



Twisted or deformed springs for the miller holders must be exchanged!

Inserting the miller into the miller holder

- Insert spring (1) straight from above into miller holder (2) - the two upper edges of the spring must be flush with the upper surface of the miller holder.
- Carefully insert miller (3) from the front - the letter 'V' must be visible.



When the miller is inserted into the holder the letter 'V' must be visible. - That way, the milling edge is pointing into the right direction.

- Insert the miller (3) completely - it must fit against the rear and lower inner surface of the miller holder (2) and be flush with spring (1).
- Insert screw (4) and washer (5) and tighten slightly to fasten miller (3).

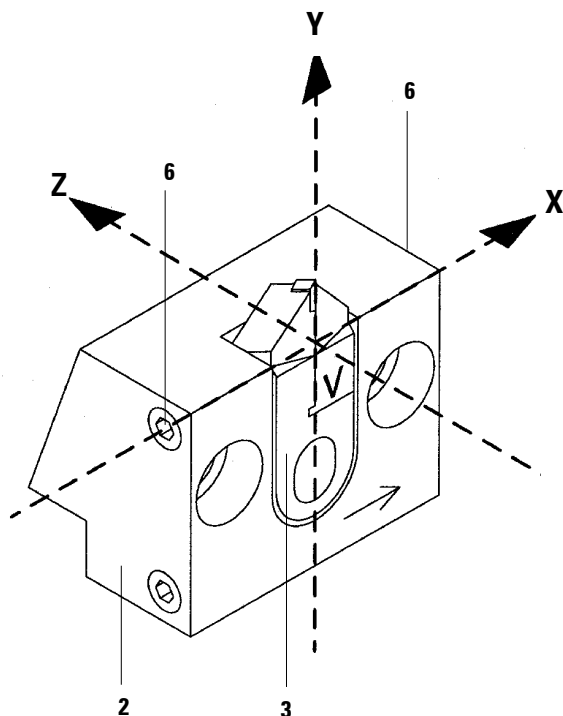

Fig. 5.3

Adjusting the miller

The miller (3) is adjusted in the holder (2) along three different axis (x, y and z - see Fig. 5.3, left). Adjustment along the x-axis is done outside the calibration device (18, Fig. 5.1).

For adjustment along the z- and y-axis, the miller holder (2) with miller (3) has to be fastened in the calibration device.

Adjustment along the x-axis

- Adjust miller (3) as shown in Fig. (5.4a / 5.4b).
- Along the entire length of both sides of the miller, there must be a uniform distance between miller (3) and miller holder (2) / spring (1) (see Fig. 5.4b).
- The miller is adjusted along the x-axis via the two regulating screws (6) (Allen key, size 2.5).
- Tighten (clockwise) and/or loosen (counterclockwise) screws (6, Fig. 5.3) alternately until the miller is adjusted to a parallel position as shown in Fig. 5.4b.

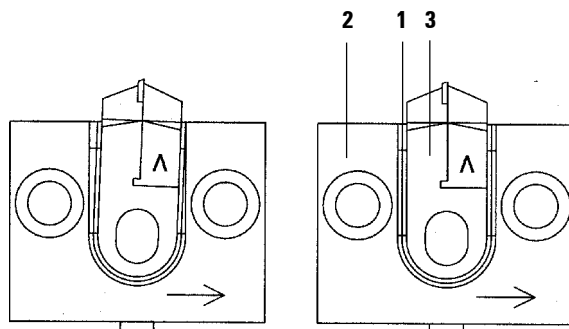

Fig. 5.4a: WRONG

Fig. 5.4b: CORRECT



Do not tighten screws (6) too much. If screws (6) are too tight, screw (7, Fig. 5.2) (for adjustment along the y-axis) can no longer be moved.

5. Operation

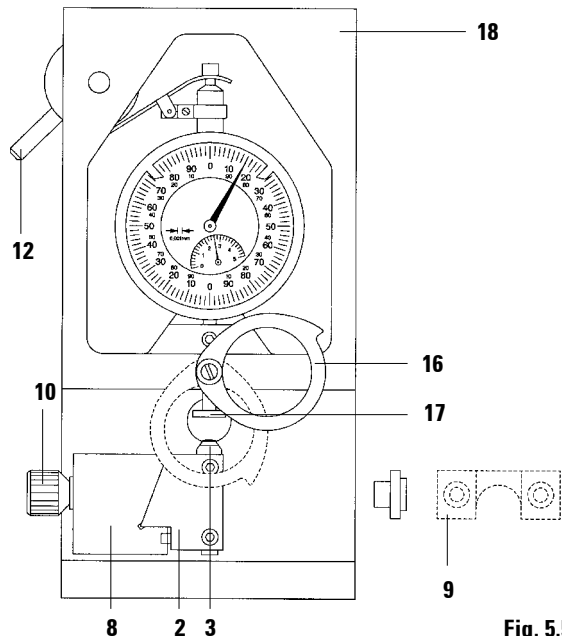

Fig. 5.5

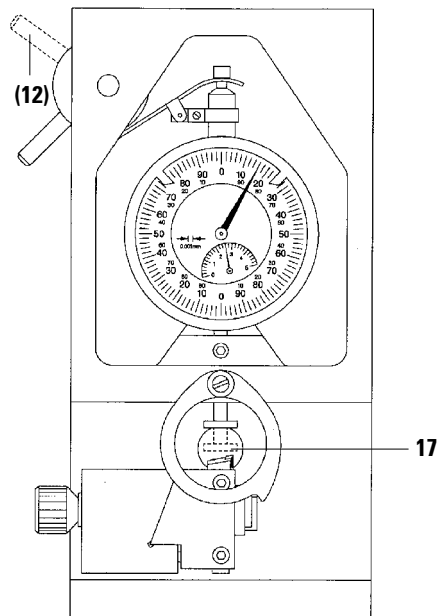

Fig. 5.6

Adjustment along the z-axis

1. Pull lever (12) at the left of calibration device (18) forward as far as it will go, thus moving contact plate (17) backwards to its rear limit position. This prevents the contact plate from hitting the milling edge during the adjustment procedure.
2. Once miller (3) has been correctly adjusted along the x-axis, place miller holder (2) with miller (3) next to block (8) into the calibration device.
3. Fit the clamping device (9) (with the semicircular recess pointing in your direction) against the miller holder (2) and fasten with two knurled screws (10) (turn screws clockwise).
4. Rotate magnifier (16) forward to a position above the miller.
5. With lever (12), bring contact plate (17) close to the miller (move lever backwards) until just a very small gap remains (see Fig. 5.6).



Caution:

The gauge contact plate must never hit the milling edge.

This could damage the surface of the contact plate, leading to incorrect measuring results.

Be very careful when bringing the contact plate close to the milling edge. Always use the magnifier.

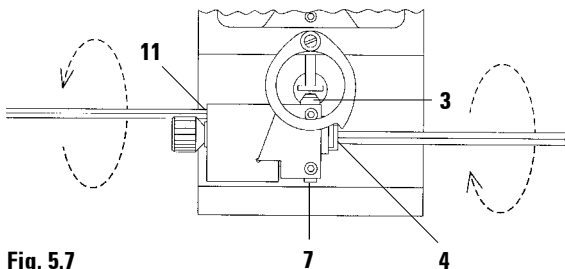

Fig. 5.7

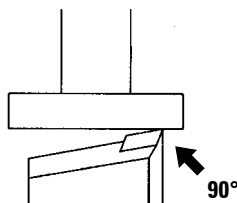

Fig. 5.8 a - CORRECT

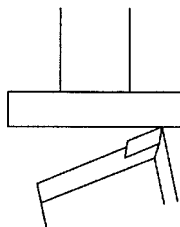

Fig. 5.8 b - WRONG

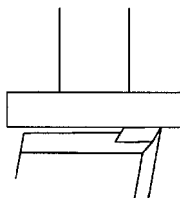

Fig. 5.8 c - WRONG

6. Insert the size-5 Allen key into regulating screw (4) insert size-2.5 Allen key into regulating screw (11) (Fig. 5.7).



The arrows in Fig. 5.7 indicate clockwise sense of rotation.

7. Tighten/loosen screws (11) and (4) alternately to adjust miller (3) along the z-axis. The miller edge is adjusted correctly when the outer edge of the miller is at right angles to the front surface of the contact plate (see Fig. 5.8a).

The miller **MUST NOT** be positioned as shown in Fig. 5.8b and 5.8c!



Tightening either regulating screw (4, 11) (= clockwise rotation in the sense of the arrow) brings the corresponding side of the miller closer to the contact plate.

8. If one of the two screws (4, 11) has been tightened as far as it will go, slightly release the opposite screw. This slackens the screw that had been completely tightened.



Do not tighten screws (4, 11) too much. If screws (4, 11) are too tight, screw (7, Fig. 5.2) (for adjustment along the y-axis) can no longer be moved.



Caution:

Be very careful when bringing the contact plate close to the milling edge.

Always use the magnifier.

Make sure the milling edge does not hit the contact plate!

5. Operation

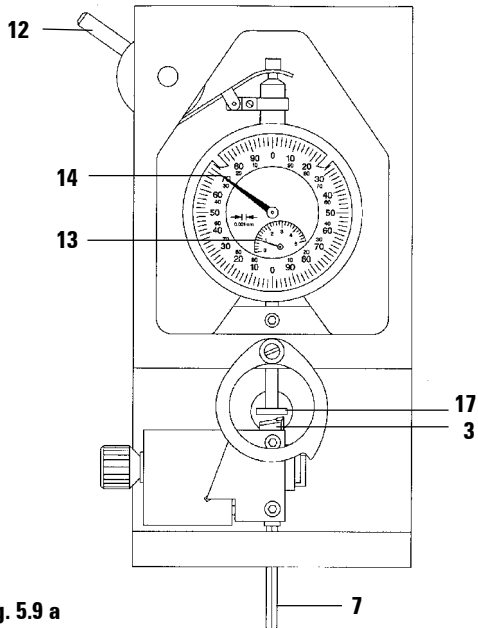

Fig. 5.9 a

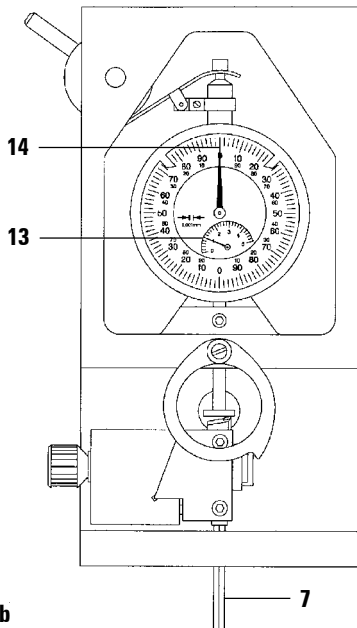

Fig. 5.9 b

Adjustment along the y-axis

1. Select reference value '1'.



The reference value will be needed later on to adjust the finishing miller to the same milling level as the pre-miller.

Any reference value can be selected. Experience, however, shows that '1' is the best value for new millers (i.e. millers not yet resharpened).

2. To select the reference value, move lever (12), setting the dial of the inner (smaller) scale (13) to a position just below '1' and the dial of the outer scale (14) to approximately '70' (approx. 10 o'clock) (Fig. 5.9a).
3. Rotate regulating screw (7) clockwise, bringing the milling edge (3) close to the contact plate (17).
4. Slowly continue to turn screw (7) clockwise until the dial of scale (14) starts to move (i.e. until the milling edge touches the contact plate).
5. Keep rotating screw (7) very carefully and slowly until the dial of scale (14) is in the upper '0' position and the dial of scale (13) is located exactly at '1' (Fig. 5.9b).



Caution:

Be very careful when bringing the contact plate close to the milling edge.

Always use the magnifier.

Make sure the milling edge does not hit the contact plate!

5.3 Adjusting the finishing millers in the calibrating device

- Carry out preparatory steps as per chapter 5.2, page 20 ('Adjusting the pre-millers in the calibrating device').



Twisted or deformed springs for the miller holders must be exchanged!

- Insert spring and finishing miller as described in chapter 5.2, page 20 ('Inserting the miller into the miller holder').



When the finishing miller is inserted into the holder, the letter 'F' must be visible. - That way, the milling edge is pointing into the right direction.

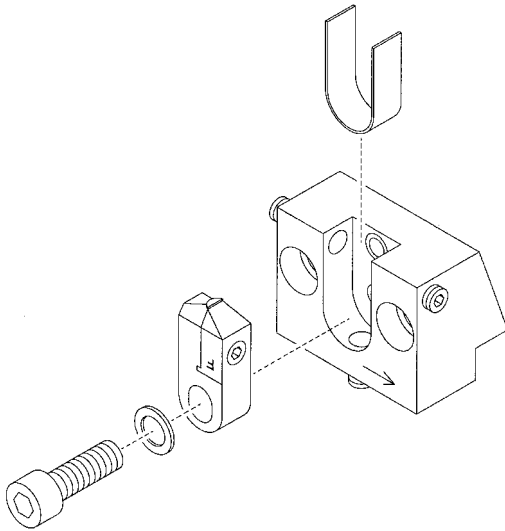

Fig. 5.10

5. Operation

Adjusting the finishing miller

Just like the pre-miller, the finishing miller is adjusted in the miller holder along three different axis (see page 21).

Adjustment along the x-axis

As described for the pre-miller - see page 21.

Adjustment along the z-axis

- Carry out steps 1 - 4 as described on page 22 (**Fig. 5.5**) for the pre-miller.

Next:

5. With lever (12), bring contact plate (17) close to the miller (turn lever backwards) so that only a small gap remains (see **Fig. 5.11**).

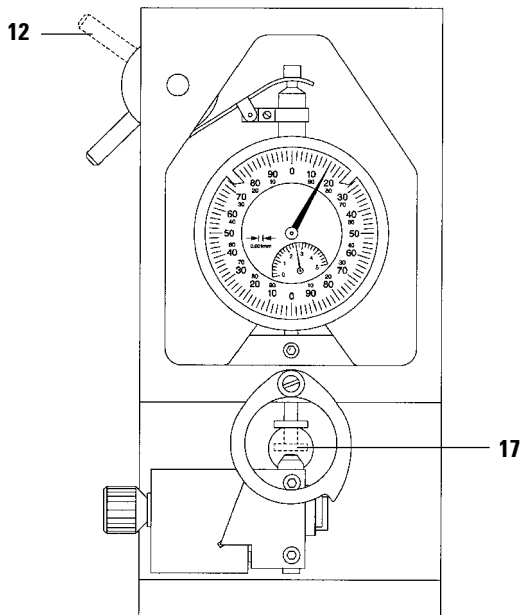

Fig. 5.11



Caution:

The gauge contact plate must never hit the milling edge.

This could damage the surface of the contact plate, leading to incorrect measuring results.

Be very careful when bringing the contact plate close to the milling edge. Always use the magnifier.

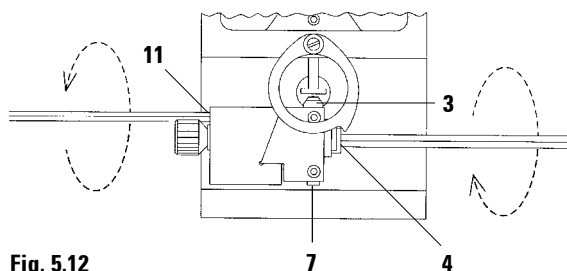

Fig. 5.12

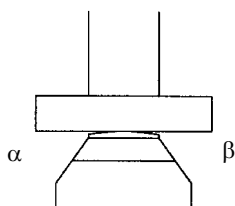

Fig. 5.13 a - CORRECT: angle α = angle β

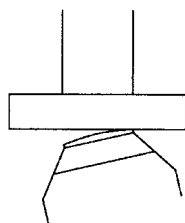

Fig. 5.13 b - WRONG

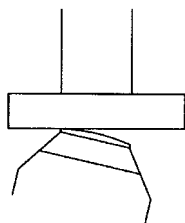

Fig. 5.13 c - WRONG

- 6 Insert size-5 Allen key into regulating screw (4) insert size-2.5 Allen key into regulating screw (11) (Fig. 5.12).



The arrows in Fig. 5.12 indicate clockwise sense of rotation.

- 7 Tighten/loosen screws (11) and (4) alternately to adjust miller (3) along the z-axis. The miller is adjusted correctly when angle ' α ' equals angle ' β ', i.e. when the distance between each end of the milling edge and the contact plate is the same: in Fig. 5.13a the finishing miller correctly adjusted.

The miller **MUST NOT** be positioned as shown in Fig. 5.13b and 5.13c!



Tightening either regulating screw (4, 11) (= clockwise rotation in the sense of the arrow) moves the corresponding side of the miller towards the contact plate.

8. If one of the two screws has been tightened as far as it will go, slightly release the opposite screw. This slackens the screw that had been completely tightened.



Do not tighten screws (4, 11) too much. If screws (4, 11) are too tight, screw (7) (for adjustment along the y-axis) can no longer be moved.



Caution:

Be very careful when bringing the contact plate close to the milling edge. Always use the magnifier. Make sure the milling edge does not hit the contact plate!

5. Operation

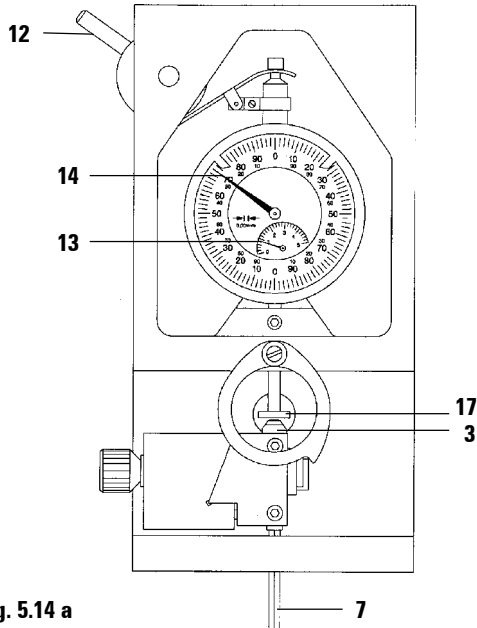

Fig. 5.14 a

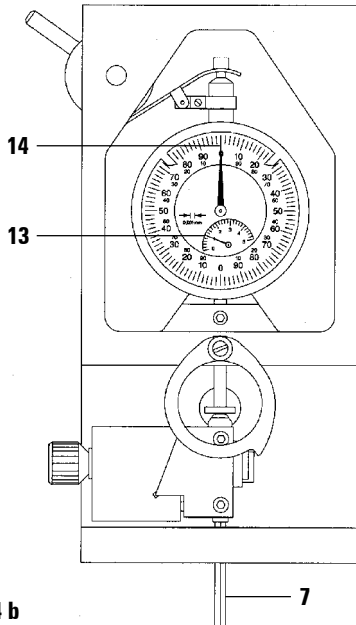

Fig. 5.14 b

Adjustment along the y-axis

- 1 Select the same reference value as was set for the pre-miller.



Pre-miller and finishing miller used for milling a specific sample must be adjusted using the same reference value. This ensures that both milling edges hit the sample at exactly the same height.

Minor differences in height can still be adjusted via the height adjustment button on the control unit, once the miller holder has been attached to the milling spindle (see chapter 5.4.13, p. 36 the Leica SM2500 manual).

- 2 To select the reference value, move lever (12), setting the dial of the inner (smaller) scale (13) to a position just below '1' and the dial of the outer scale (14) to approximately '70' (approx. 10 o'clock) (Fig. 5.14a).
- 3 Rotate regulating screw (7) clockwise, bringing the milling edge (3) close to the contact plate (17).
- 4 Slowly continue to turn screw (7) clockwise until the dial of scale (14) starts to move (i.e. until the milling edge touches the contact plate).
- 5 Keep rotating screw (7) very carefully and slowly until the dial of scale (14) is in the upper '0' position and the dial of scale (13) is located exactly at '1' (Fig. 5.14b).



Caution:

Be very careful when bringing the contact plate close to the milling edge. Always use the magnifier. Make sure the milling edge does not hit the contact plate!

5.4 Specimen holder systems - how to combine individual components

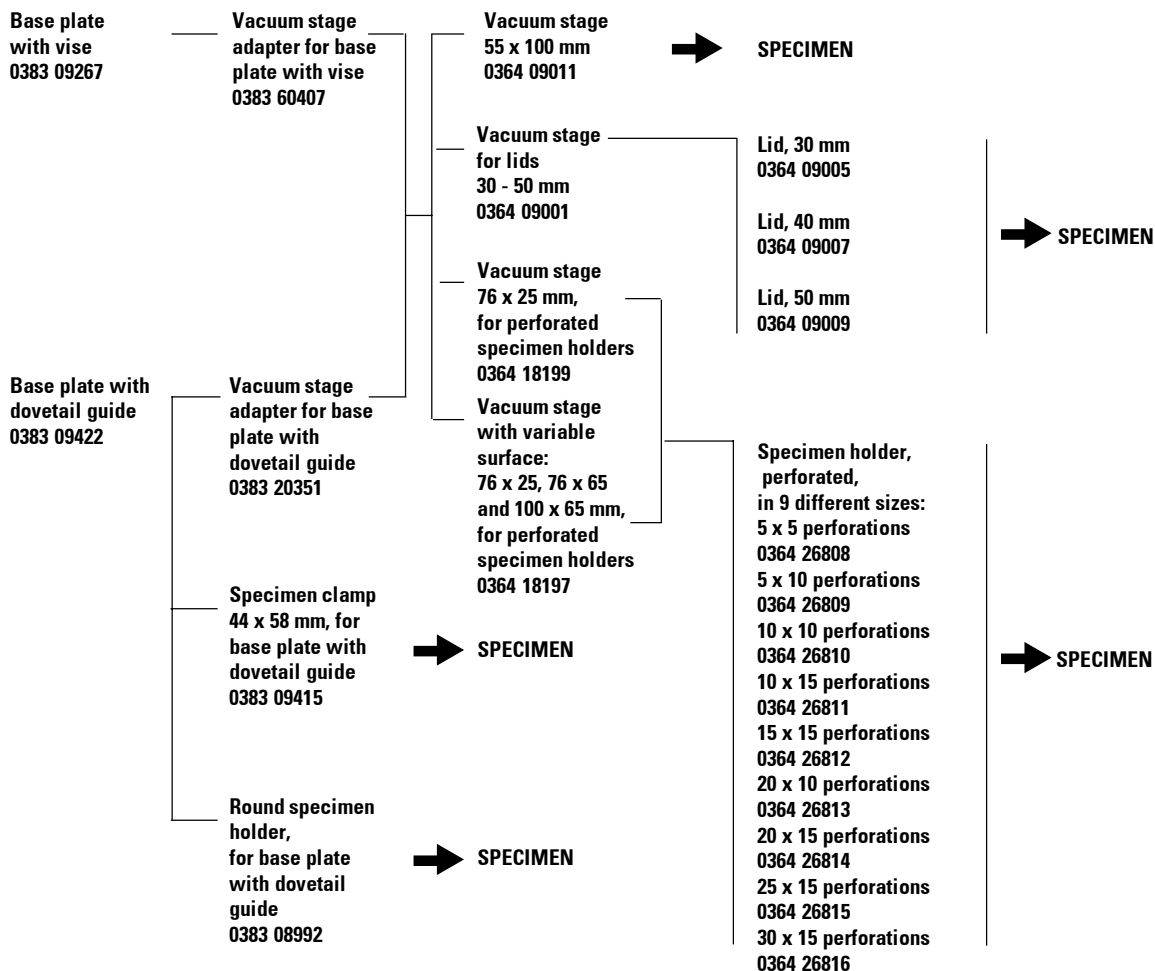

Configurations:

1. Base plate with dovetail guide (0383 09422) and holder for round specimens (0383 08992)
= order no. 0383 08993
2. Base plate with dovetail guide (0383 09422) and specimen clamp 44 x 58 mm (0383 09415) with eccentric ring (0383 09425)
= order no. 0383 20212
3. Vacuum stage 76 x 25 mm with vacuum stage adapter (0383 60407) for base plate with vise (0383 09267)
= order no. 0364 18200

5. Operation

5.5 Clamping specimen



For a detailed overview of the clamping systems available, please refer to chapter, 5.4, page 29.

5.5.1 Installing the base plates in the basic instrument



For detailed instructions on how to install the base plates in the basic instrument, please refer to chapters 5.5/5.5.1, pages 38/39 of the Leica SM2500 instruction manual.

When working with the Leica SP2600 ultramilling attachment, always insert the eccentric ring prior to installing the base plates. The eccentric ring blocks the specimen orientation mechanism thus providing enhanced stability during milling.

For details on how to insert the eccentric ring, please refer to chapter 5.5/5.5.1, page 39 of the Leica SM2500 instruction manual.

5.5.2 Clamping the specimen holders in the base plate with dove tail guide



For detailed instructions on how to clamp the specimen clamp 44 x 58 mm and/or the round specimen holder in the base plate with dovetail guide as well as on how to clamp specimens in these specimen holders, please refer to chapter 5.5.4 'Mounting specimen holders onto the base plate with dovetail guide', pages 42 - 44 of the Leica SM2500 instruction manual.

5.5.3 Clamping the vacuum stages on/in the base plates

Clamping the vacuum stages in the base plate with vise (Fig. 5.15)

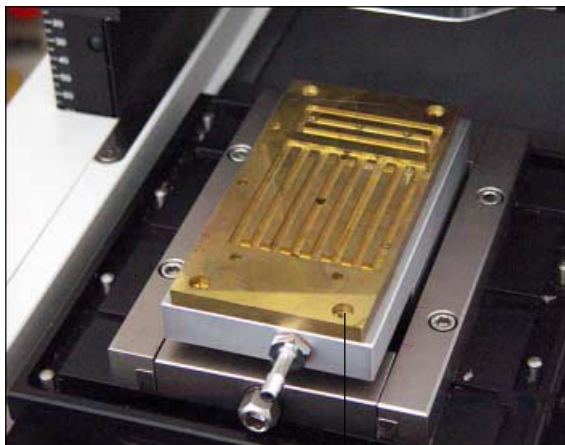

Fig. 5.15

1

- Fasten the vacuum stage on the vacuum stage adapter for the base plate with vise (with 4 Allen screws (1) / Allen key size 4). The 4 size-four Allen screws are part of the 'Vacuum stage adapter' standard delivery, the size-four Allen key comes as part of the Leica SP2600 standard delivery.

- Clamp the vacuum stage in the base plate with vise.

For detailed instructions on how to do this, please refer to chapter 5.5.2, page 41 'Clamping specimen stages' of the Leica SM2500 instruction manual: the vacuum stage is clamped the same way as the specimen stages described there.

Clamping the vacuum stages in the base plate with dovetail guide (Fig. 5.16)



Fig. 5.16

- Fasten the vacuum stage on the vacuum stage adapter for the base plate with dovetail guide (with 4 Allen screws (1) / Allen key size 3). The 4 size-three Allen screws are part of the 'Vacuum stage adapter' standard delivery, the size-three Allen key comes as part of the Leica SM2500 standard delivery.

- Clamp the vacuum stage in the base plate with dovetail guide.

For detailed instructions on how to do this, please refer to chapter 5.5.4, page 44 'Clamping the round specimen holder' of the Leica SM2500 instruction manual: the vacuum stage is clamped the same way as the round specimen holder.

5. Operation

5.5.4 Connecting the vacuum pump / placing specimens onto the vacuum stages



Fig. 5.17

1 2

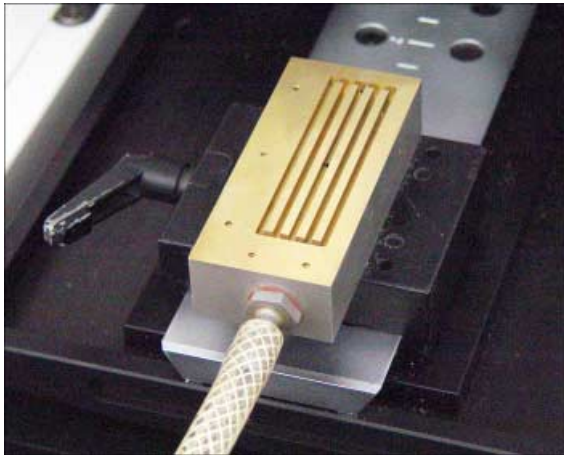

Fig. 5.18



IMPORTANT:

Prior to first use, every vacuum table surface must be milled once, just like a specimen surface. This ensures that the surface of the specimens milled on the table later on will be perfectly even.

To mill a table surface, carry out one entire pre- and finishing milling cycle as per chapters 5.6 - 5.8, pages 34 - 43 of this manual.

Connecting the vacuum pump

- Place vacuum pump (make sure the voltage rating of the vacuum pump is appropriate for the mains supply in your laboratory!) on the floor underneath the microtome bench.
- Connect vacuum pump to mains.
- Slide connecting hose (1) (part of standard delivery of Leica vacuum pumps) onto the nozzle on vacuum pump (2).
- Connect the other end of connecting hose (1) to the nozzle (3) of the vacuum stage.
- Place the specimen onto the vacuum stage.



There are different types of vacuum stages for different specimen sizes - see next page.

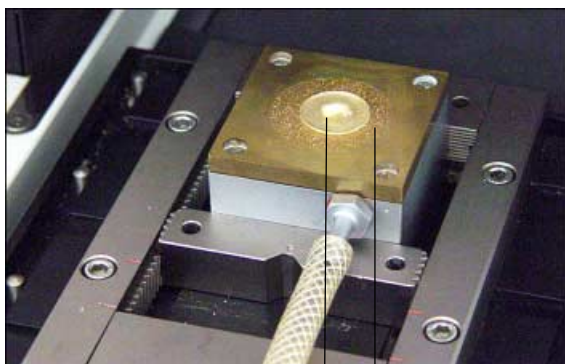

Fig. 5.19

1 2

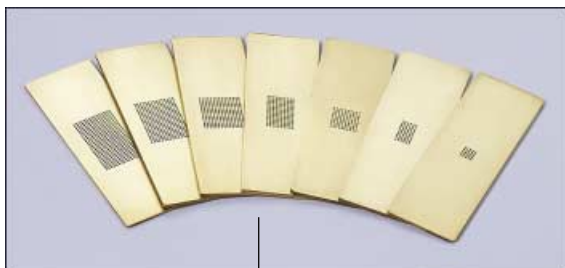

Fig. 5.20

3

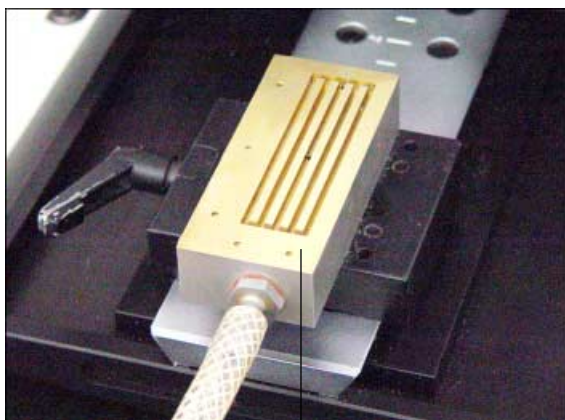

Fig. 5.21

4

Placing specimens onto vacuum stage for 30 - 50-mm lids

- Fasten a lid suited to the size of the specimen to be milled onto the vacuum stage (slotted screws are part of standard delivery of vacuum stage lids - use slotted screwdriver).
- Place the specimen (1) onto the sintered surface (2) of the lid.
- Switch on the vacuum pump.

Placing specimens onto vacuum stages for perforated specimen holders

- Fasten a perforated specimen holder (3) suited to the size of the specimen on the vacuum stage 76 x 25 mm (4) or onto the vacuum stage with variable surface (not shown here).
- Place specimen on the perforated area of the vacuum stage
- Switch on the vacuum pump.



The following is recommended for all vacuum stages, no matter of which type and size:

If the specimen is smaller than the sintered or perforated stage surface, the entire stage surface not covered by the specimen should be covered with autoadhesive plastic film.

Placing specimens onto vacuum stage 55 x 100 mm

- Place the specimen directly on the sintered surface area of the vacuum stage. (Vacuum stage 55 x 100 mm not shown here).

5. Operation

5.6 Preparatory steps prior to the milling procedure



For a detailed description of all control elements located on the control unit, please refer to chapters 5.3 ('Overview - control panel') and 5.4 ('Description of each individual control element') of the Leica SM2500 instruction manual.



- Select manual mode of operation **MAN** (button (5) - chapter 5.4.3, page 26, Leica SM2500 instruction manual).

In 'MAN' mode, carry out the following preparatory steps:



- Move the milling spindle to the upper limit position (button (48), chapter 5.4.13, p. 36, Leica SM2500 manual) and open the plexiglass cover.
- Attached the miller holder (1) (containing the adjusted pre-miller) to the milling spindle (use Allen screws size 5 (2) / Allen key size 5 - part of SP2600 standard delivery).



Always slide plexiglass cover to upper position prior to attaching the miller holders to the milling spindle!

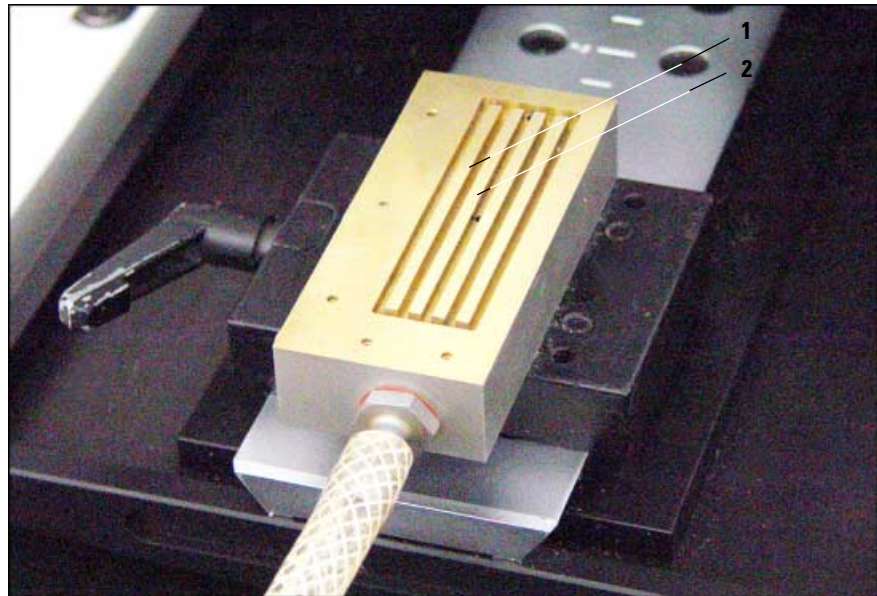

Fig. 5.22

- Insert the specimen (see chapters 5.5.2 and 5.5.4, pages 30 and 33 of this manual) or - if you need to mill a vacuum table prior to first use - see chapter 5.5.3, page 31 of this manual).



Wear protective gloves when working with potentially infectious specimen material!



or



- Move the specimen sledge underneath the miller (buttons **(56)** or **(57)**, chapter 5.4.14, page 37, Leica SM2500 instruction manual).



- Set the milling window (button **(61)** and others - see chapter 5.4.14, page 37, Leica SM2500 instruction manual).



- Press button **(51)** (chapter 5.4.13, page 36, Leica SM2500 manual) to bring the cutting edge of the miller close to the specimen surface (coarse adjustment - small gap must still remain).



Always slide the plexiglass cover to the upper position prior to the distance check 'milling edge / specimen surface'! - Risk of injury!



or



- Next, use buttons **(50)** and/or **(49)** (see chapter 5.4.13, page 36, Leica SM2500 instruction manual) for fine adjustment of the distance between milling edge and specimen surface.
- Check the remaining distance in three different zones of the specimen surface (beginning/center/end) moving the specimen sledge via buttons **(56)** - **(59)**, see chapter 5.4.14, page 37, Leica SM2500 manual) - the cutting edge of the miller should just about touch the specimen surface.



Caution:

Always check the distance between miller cutting edge and specimen surface thoroughly prior to milling!

Under no circumstances may the miller cutting edge be positioned more than a few microns (= selected milling thickness) below the specimen surface when starting the milling procedure.



If the surface height of the specimen is uneven, the cutting edge should just about touch the highest point of the specimen. - Then mill the specimen until the surface is completely level.

5. Operation

5.7 Pre-milling



- Select automatic mode of operation '**AUTO**' (button **(5)** - chapter 5.4.3, page 26 Leica SM 2500 instruction manual).



or



In 'AUTO' mode, set the milling parameters for the pre-milling procedure:

- Select STOP or PHOTO position (buttons **(23)** or **(26)** chapter 5.4.8, page 31 - Leica SM2500 instruction manual).



+



- Select milling thickness (button **(10)** / rotary selector switch **(9)** - see chapters 5.4.4 and 5.4.5, pages 27/28 - Leica SM2500 instruction manual). (**--> see following page for recommended settings**).

- Activate retraction (button **(10)** / rotary selector switch **(9)** - see chapters 5.4.4 and 5.4.5, pages 27/28 - Leica SM2500 instruction manual).



+



- Select milling and return stroke speed. (button **(19)** / rotary selector switch **(9)** - see chapter 5.4.4, page 27 and chapter 5.4.7, page 30 - Leica SM2500 instruction manual). (see next page for recommended settings).

- Close plexiglass protective cover.



- Start miller rotation (button **(37)** - chapter 5.4.11, page 34 - Leica SM2500 instruction manual).



or



- Select rotational speed of miller (buttons **(39)**, **(40)** - chapter 5.4.11, page 34 - Leica SM2500 instruction manual).



- Select desired milling mode (button **(15)** - chapter 5.4.6. page 29 - Leica SM2500 instruction manual).



Individual parameter settings depend on specimen material and size. Please refer to the following page for a list of recommended settings.

Recommended milling thickness settings for pre-milling

- 10 µm - keep milling until surface is completely level.
- 5 µm - three entire sledge strokes (milling and return stroke).
- 3 µm - three entire sledge strokes (milling and return stroke).



Do not exceed a milling thickness setting of 5 µm with the following materials: brittle, very ductile materials such as titanium or fiberglass and compound samples containing such materials (such as printed circuit boards).

Recommended sledge speed settings for pre-milling

- Milling stroke: 1.5 mm/s
- Return stroke: any speed

Recommended rotational speed of miller for pre-milling

- 2,000- 3,000 rpm (depending on specimen type)

Recommended mode of operation for pre-milling

- Select 'continuous' mode of operation.

Starting the milling procedure



During milling:

- switch on the vacuum cleaner,
- wear appropriate safety goggles,
- wear appropriate mask (type of mask depends on the material being milled / size of the chips that form during milling).

Goggles and mask prevent milling chips and microdust from entering your eyes and from being inhaled.



- Switch on the vacuum cleaner (via button (35) on the control unit - see chapter 5.4.11, page 34 of Leica SM2500 instruction manual) or via the on/off switch of the vacuum cleaner itself.



- Start sledge stroke (buttons (29), (30) - chapter 5.4.10, p. 33 - Leica SM 2500 instruction manual).

- Carry out the milling steps as per above recommendation.

--> See next page for a perspective view of the pre-milling procedure.

5. Operation

5.7.1 Perspective view of the pre-milling procedure

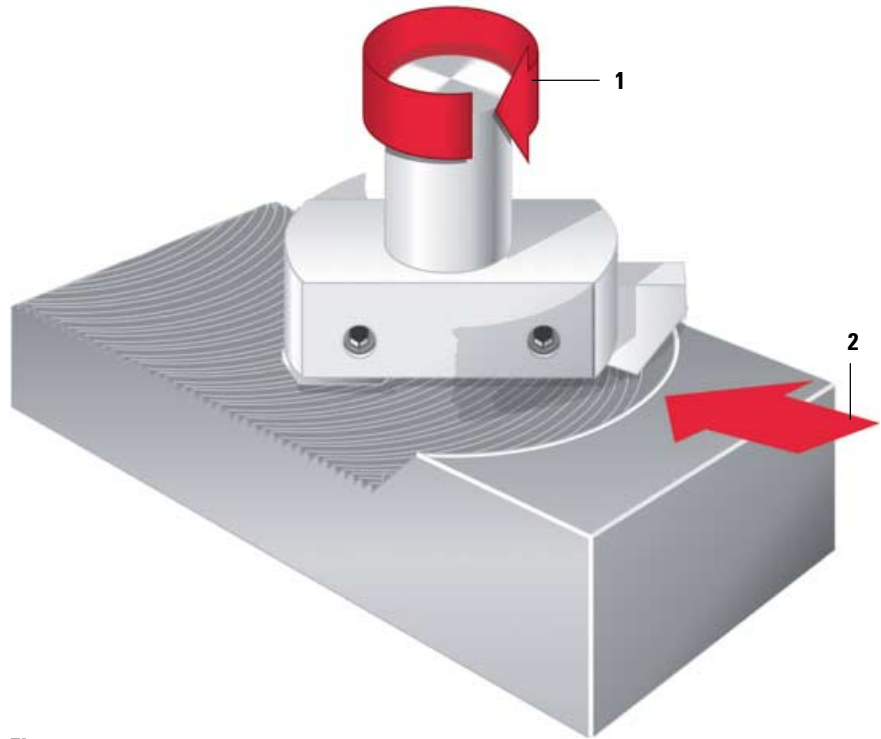

Fig. 5.23

Pre-milling procedure

The milling spindle carrying the pre-miller rotates clockwise (circular arrow (1)) while the specimen sledge passes underneath the miller in the direction of arrow (2).

The pre-miller leaves a serrated surface texture which is then in a second milling procedure milled to a mirrorlike, even surface by the finishing miller (see Fig 5.24 p. 42).

Ending the pre-milling procedure



or



- Press **RUN STOP** or **RUN ENABLE** to stop the sledge (buttons (29), (30) - Chapter 5.4.10, page 33 - Leica SM2500 manual) - or, when working in 'PROG' mode of operation, wait for the programmed number of strokes to be finished (see chapter 5.4.3, page 26, Leica SM2500 manual).
- If the specimen sledge has not stopped in the front limit position, activate manual mode of operation **MAN** (button (5) - chapter 5.4.3, page 26, Leica SM2500 manual) and move the specimen to the front limit position (via buttons (58) or (59) - chapter 5.4.14, page 37- SM2500 manual) .
- Stop miller rotation (button (37) - chapter 5.4.11, page 34 - Leica SM2500).



**After switching off the milling spindle (button (37) - chapter. 5.4.11, p. 34 - instruction manual Leica SM2500) the miller continues to rotate for a little while!
Risk of injury!**

- Slide plexiglass protective cover to upper position.



Never touch the milling spindle while it is rotating and/or while the plexiglass cover is shut, no matter whether the spindle is rotating or not.

- Remove the miller holder containing the pre-miller.

5. Operation

5.8 Finishing milling

- Attach the miller holder containing the finishing miller to the milling spindle (Allen screws / Allen key size 5) - see Fig. 5.21, page 34).



Always slide the plexiglass cover to the upper limit position prior to attaching the miller holders to the milling spindle!

- Bring the cutting edge of the miller close to the specimen surface and thoroughly check the distance between miller cutting edge and specimen surface as described for the pre-miller on page 35.
- If necessary, adjust the milling window (button **(61)** and others - see chapter 5.4.14, page 37 of Leica SM2500 instruction manual).

Setting the milling parameters for the finishing milling procedure

- Once again activate automatic mode of operation '**AUTO**' and set the milling parameters using the same control unit buttons as described for the pre-miller on page 36.



Individual parameter settings depend on specimen material and size. Please refer to the recommendations below and on the following page.

Recommended milling thickness settings for finishing milling

- 5 μm - keep milling until surface is completely level.
- 3 μm - three entire sledge strokes (milling and return stroke).
- 2 μm - three entire sledge strokes (milling and return stroke).
- 1 μm - three entire sledge strokes (milling and return stroke).



Do not exceed a milling thickness setting of 5 μm with the following materials: brittle, very ductile materials such as titanium or fiberglass and compound samples containing such materials (such as printed circuit boards).

Recommended sledge speed settings for finishing milling

- Milling stroke: 0.5 mm/s to 1.0 mm/s
- Return stroke: any speed

Recommended rotational speed of miller for finishing milling

- < 2.000 rpm

Recommended mode of operation for finishing milling

- Select 'continuous' mode of operation.

Starting the milling procedure



During milling:

- switch on the vacuum cleaner,
 - wear appropriate safety goggles,
 - wear appropriate mask (type of mask depends on the material being milled / size of the chips that form during milling).
- Goggles and mask prevent milling chips and microdust from entering your eyes and from being inhaled.**



- Switch on the vacuum cleaner (via button (35) on the control unit - see chapter 5.4.11, page 34 of Leica SM2500 instruction manual) or via the on/off switch of the vacuum cleaner itself.
- Start sledge stroke (buttons (29), (30) - chapter 5.4.10, p. 33 - Leica SM 2500 instruction manual).
- Carry out the milling steps as per above recommendation.



Important note:

If you need to mill several specimens with identical results (e.g. for examining a specimen layer located at a certain level), completely identical parameters have to be selected for each specimen (for pre-milling as well as for the finishing milling procedure).

--> See following page for a perspective view of the finishing milling procedure.

5. Operation

5.8.1 Perspective view of the finishing milling procedure

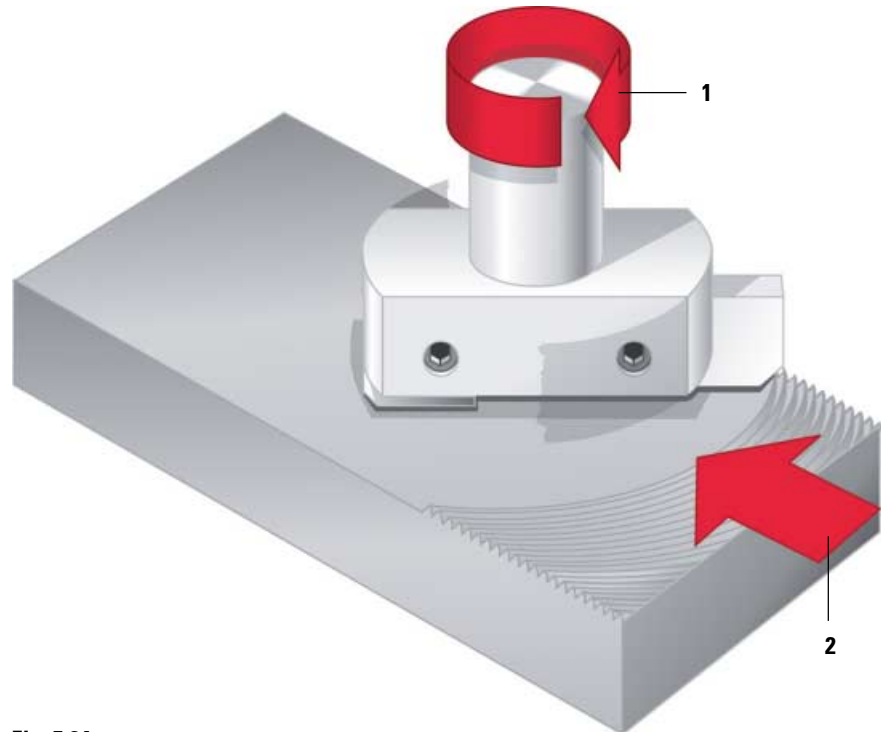

Fig. 5.24

Finishing milling procedure

The milling spindle carrying the finishing miller rotates clockwise (circular arrow (1)) while the specimen sledge passes underneath the miller in the direction of arrow (2).

The serrated surface structure created by the pre-miller (see Fig 5.23 p. 38) is converted by the finishing miller into a mirrorlike, completely even surface.

Ending the finishing milling procedure



or



- Press **RUN STOP** or **RUN ENABLE** to stop the sledge (buttons (29), (30) - chapter 5.4.10, page 33 - Leica SM2500 manual) - or, when working in 'PROG' mode of operation, wait for the programmed number of strokes to be finished (see chapter 5.4.3, page 26, Leica SM2500 manual)
- If the specimen sledge has not stopped in the front limit position, activate manual mode of operation **MAN** (button (5) - chapter 5.4.3, page 26, Leica SM2500 manual) and move the specimen to the front limit position (via buttons (58) or (59) - chapter 5.4.14, page 37- SM2500 manual) .
- Stop miller rotation (button (37) - chapter 5.4.11, page 34 - Leica SM2500).



**After switching off the milling spindle (button (37) - chapter. 5.4.11, p. 34 - instruction manual Leica SM2500) the miller continues to rotate for a little while!
Risk of injury!**

- Remove the specimen for subsequent microscopic examination.
- Slide plexiglass protective cover to upper position.



Never touch the milling spindle while it is rotating and/or while the plexiglass cover is shut, no matter whether the spindle is rotating or not.

- Remove the finishing miller.

5.9 Switching the instrument off (switching off the control unit)

- Once all milling procedures have been completed or at the end of your workday, switch off the mains switch at the rear of the control unit.



**When switching off the mains switch on the control unit (see chapter 5.2, p. 21 - Instruction manual Leica SM2500) the milling spindle will rotate briefly.
Therefore, never switch off the control unit, while one of your hands is in the rotation zone of the miller.
- Risk of injury!.**

6. Troubleshooting

6. Troubleshooting

For all instructions on error detection and trouble shooting, please refer to chapter 6, page 64 of the Leica SM2 500 instruction manual .

7.1 Cleaning and disinfection



Only authorized service technicians may access the internal components of the instrument for service and repair!

Cleaning detergents appropriate for the ultramilling attachment - varnished surfaces:

- mild laboratory detergents (slightly moistened cloth)!

non-varnished metal parts:

- mild laboratory detergents,
- xylene substitutes (slightly moistened cloth)
- alcohol (slightly moistened cloth).

No liquids may enter the interior of the instrument during cleaning!

Cleaning

- Clean the basic instrument Leica SM2500 as per the instructions in chapter 7.1, pages 65 - 67 of the Leica SM2500 instruction manual.
- Clean the Leica SP2600 with a soft, slightly moistened cloth using one of the detergents listed above.
- Clean diamond millers with a soft cloth moistened with alcohol.



For disinfection of the instrument and accessories use Leica Cryofect or other commercial disinfectants. - Use all disinfectants according to the manufacturer's instructions!

No liquids may enter the interior of the instrument during disinfection!

When disinfecting, wear appropriate goggles and mask as well as protective gloves!

Dispose of potentially infectious specimen material as per the laboratory regulations applicable in the country of operation!

Disinfection

- Remove potentially infectious milling waste / remaining samples and dispose of as per the regulations applicable.
- Disinfect instrument and accessories as per the instructions of the disinfectant manufacturer.

7. Cleaning, disinfection and maintenance

7.2 Maintenance



Only authorized service technicians may access the internal components of the instrument for service and repair!

No liquids may enter the interior of the instrument during maintenance!

- Carry out the maintenance steps to be done by the user as per the instructions in chapter 7.2, pages 67 - 70 of the Leica SM2500 instruction manual.
- In addition to the maintenance steps listed in the Leica SM2500 manual, the following maintenance work is required for the Leica SP2600:
chapter 7.2.1 - Resharpener the millers.
chapter 7.2.2 - Replacing the light bulb in the calibration device.

7.2.1 Resharpener the millers

- The millers need to be resharpened as soon as the milled specimen surfaces no longer have a smooth, mirrorlike appearance and/or when milling residues / residues of a grimy appearance start to accumulate on the specimen surface.

7.2.2 Replacing the light bulb in the calibration device

- Remove base cover (2) of calibration device (1) (unscrew 4 slotted screws (3)).
- Loosen light bulb holder (5) (metal bridge with lamp socket) (unscrew 2 slotted screws (4)).
- Take replacement light bulb (8) out of sponge rubber cube (7).
- Remove broken light bulb (6) from lamp socket and replace with new light bulb (8).
- Place another replacement bulb (8) into the sponge rubber cube (7).
- Put light bulb holder (5) back in place.
- Place ring with cable (9) onto bore (10) in the light bulb holder.
- Fasten light bulb holder with two screws (4).
- Put sponge rubber cube (7) with new replacement light bulb (8) back into the calibration device.
- Put base cover (2) back in place and fasten with 4 screws (3).

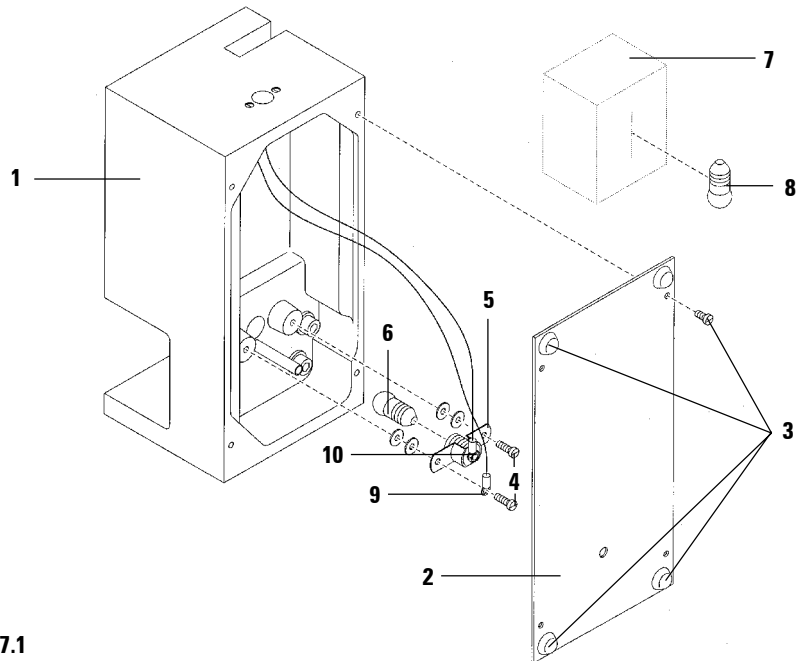

Fig. 7.1

8. Overview - accessories

8.1 Miller holders and millers

Miller holder

Holder for pre- and finishing miller

Pre-miller

- Pre-miller D - with diamond edge, cutting angle -1° , clearance angle $+3^\circ$

Finishing miller

- Finishing miller D - with diamond edge, cutting angle $+3^\circ$, clearance angle $+4^\circ$, for milling plastics
- Finishing miller D - with diamond edge, cutting angle -8° , clearance angle $+1.5^\circ$, for milling precious and nonferrous heavy metals
- Finishing miller D - with diamond edge, cutting angle -1° , clearance angle $+1.5^\circ$, for milling light metals
- Finishing miller D - with diamond edge, cutting angle -5° , clearance angle $+1.5^\circ$, for milling light metals
- Counterbalance insert - for Leica SP2600 - to be used instead of a pre- or finishing miller

8.2 Base plates for specimen holders and vacuum stage adapters

- Base plate with vise
- Base plate with dovetail guide

8.3 Specimen holders

- Specimen clamp 44 x 58 mm, for base plate with dovetail guide
- Round specimen holder, for base plate with dovetail guide

8.4 Vacuum stage adapters

- Vacuum stage adapter for base plate with vise
- Vacuum stage adapter for base plate with dovetail guide

8.5 Vacuum stages and matching lids / perforated specimen holders

- Vacuum stage for Leica SP2600 - basic body for lids 30 - 50 mm
 - Lid, 30 mm, for Leica SP2600 vacuum stage
 - Lid, 40 mm, for Leica SP2600 vacuum stage
 - Lid, 50 mm, for Leica SP2600 vacuum stage
- Vacuum stage for Leica SP2600 - 55 x 100 mm
- Vacuum stage, 76 x 25 mm
Available either configured (with vacuum stage adapter for base plate with vise) or without vacuum stage adapter.
To be used with several different perforated specimen holders:
 - specimen holder, 5 x 5 perforations
 - specimen holder, 5 x 10 perforations
 - specimen holder, 10 x 10 perforations
 - specimen holder, 10 x 15 perforations
 - specimen holder, 15 x 15 perforations
 - specimen holder, 20 x 10 perforations
 - specimen holder, 20 x 15 perforations
 - specimen holder, 25 x 15 perforations
 - specimen holder, 30 x 15 perforations
- Vacuum stage, with variable surface: 76 x 25 mm, 76 x 56 mm and 100 x 65 mm.
To be used with the same perforated specimen holders as vacuum stage 76 x 25 mm.

8.6 Vacuum pumps

- Vacuum pump, 230 V, 50 Hz
- Vacuum pump, 120 V, 60 Hz

8.7 Additional accessories

Vacuum cleaner and vacuum cleaner accessories

- Vacuum cleaner 'Fakir S20', with connection hose
230 V / 50 Hz only
- Set of vacuum cleaner bags for Fakir S 20

Illumination

- Halogen spotlight illumination
230 V/50 Hz only

9. Warranty and service

For all information on warranty and service, please refer to chapter 9, pages 74 - 76 of the Leica SM2500 instruction manual.

Free Manuals Download Website

<http://myh66.com>

<http://usermanuals.us>

<http://www.somanuals.com>

<http://www.4manuals.cc>

<http://www.manual-lib.com>

<http://www.404manual.com>

<http://www.luxmanual.com>

<http://aubethermostatmanual.com>

Golf course search by state

<http://golfingnear.com>

Email search by domain

<http://emailbydomain.com>

Auto manuals search

<http://auto.somanuals.com>

TV manuals search

<http://tv.somanuals.com>