

LENNOX[®]

©2001 Lennox Industries Inc.
Dallas, Texas, USA

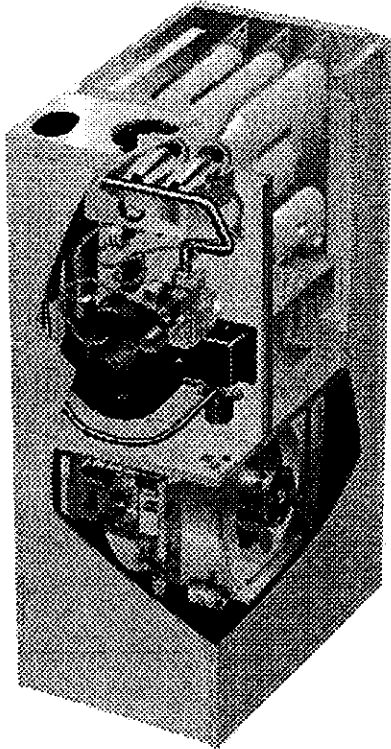

**RETAIN THESE INSTRUCTIONS
FOR FUTURE REFERENCE**

INSTALLATION INSTRUCTIONS

G32Q SERIES UNITS

GAS UNITS
504,488M
11/2001
Supersedes 504,382M

TP Technical
Publications
Litho U.S.A.

Table of Contents

Unit Dimensions	2
G32Q Parts Arrangement	3
Requirements	4
General	5
Installation - Setting Equipment	5
Return Air Opening Guidelines	5
Filters & Optional Filter Assembly	6
Duct System	7
Pipe & Fittings Specifications	7
Vent Piping Guidelines	8
Joint Cementing Procedure	8
Venting Practices	9
Gas Piping	15
Electrical	16
Unit Start-Up	21
Heating Sequence of Operation	22
Blower Operation	22
Gas Pressure Adjustment	22
High Altitude Information	23
Other Unit Adjustments	23
Service	24
Repair Parts	27
Troubleshooting	27
Start-Up & Performance Checklist	32



⚠ WARNING

If the information in this manual is not followed exactly, a fire or explosion may result causing property damage, personal injury or death.



Do not store or use gasoline or other flammable vapors and liquids in the vicinity of this or any other appliance.

Installation and service must be performed by a qualified installer, service agency or the gas supplier.

WHAT TO DO IF YOU SMELL GAS:

- Do not try to light any appliance.
- Extinguish any open flames.
- Do not touch any electrical switch; do not use any phone in your building.
- Immediately call your gas supplier from a neighbor's phone. Follow the gas supplier's instructions.
- If you cannot reach your gas supplier, call the fire department.

11/01



Page 1

504,488M



G32Q Unit Dimensions - Inches (mm)

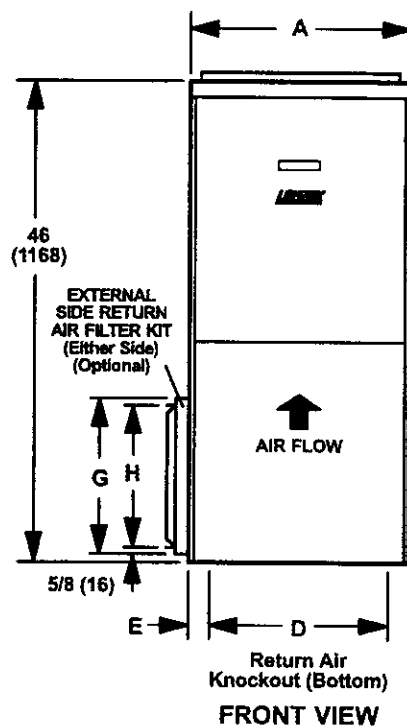
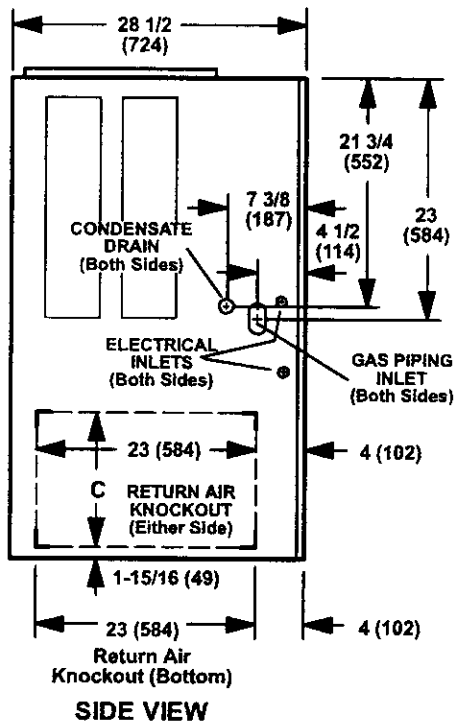
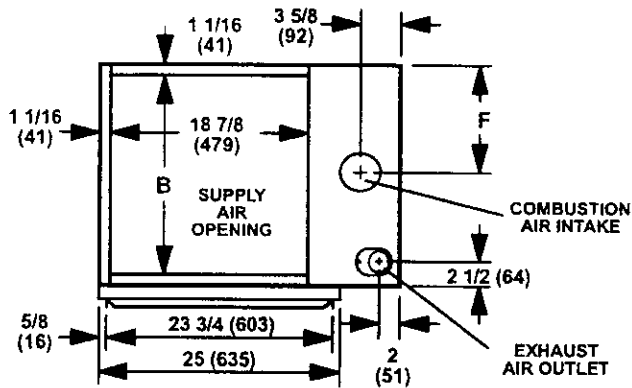

Model No.	A		B		C		D		E		F		G		H	
	in.	mm	in.	mm	in.	mm	in.	mm	in.	mm	in.	mm	in.	mm	in.	mm
G32Q3-75	16-1/4	413	14-1/8	359	12	305	12	305	2-1/8	54	7-5/8	194	14	356	12-3/4	324
G32Q3/4-100 G32Q4/5-100	21-1/4	540	19-1/8	486	18	457	18	457	1-5/8	41	10-1/8	257	20	508	18-3/4	476
G32Q4/5-125	26-1/4	667	24-1/8	613	18	457	18	457	4-1/8	105	12-5/8	321	20	508	18-3/4	476

G32Q Parts Arrangement

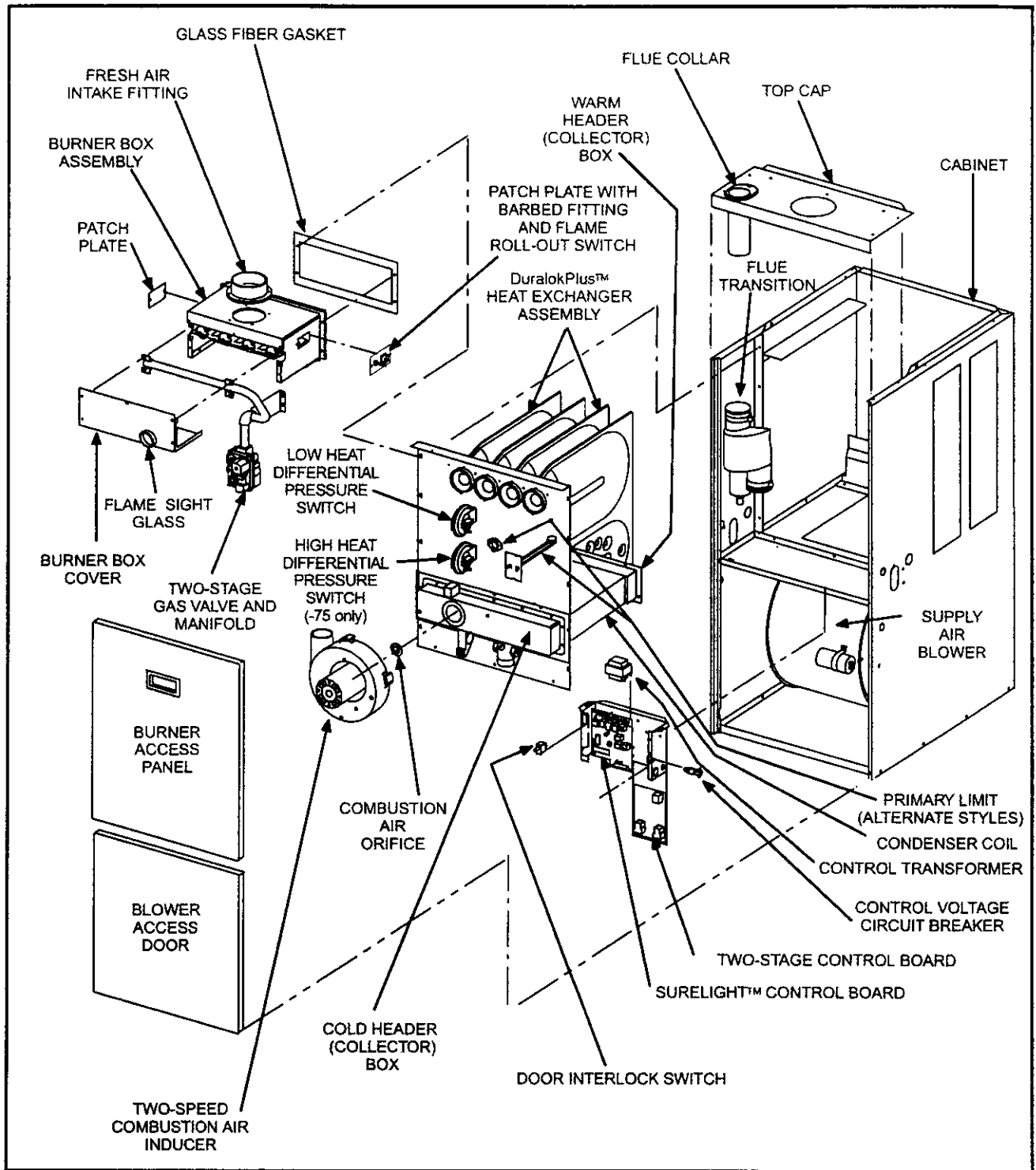

FIGURE 1

Requirements

Lennox G32Q units are CSA International certified to ANSI Z21.47 and CSA 2.3 standards.

In the USA, installation of Lennox gas central furnaces must conform with local building codes. In the absence of local codes, units must be installed according to the current National Fuel Gas Code (ANSI-Z223.1) in the United States. The National Fuel Gas Code is available from the following address:

American National Standards Institute, Inc.
11 West 42nd Street
New York, NY 10036

In Canada, installation must conform with current National Standard of Canada CAN/CGA-B149.1 "Installation Code for Natural Gas Burning Appliances and Equipment" and CAN/CGA-B149.2 "Installation Code for Propane Gas Burning Appliances and Equipment," local plumbing or waste water codes and other applicable local codes.

This furnace is CSA International certified for installation clearances to combustible material as listed on the unit rating plate and in table 1.

TABLE 1

Clearances	Location	Inches (mm)
Service access	Front	24 (610)
	Condensate side	3 (76) (from side of unit)
To combustible materials	Top	1 (25)
	Exhaust	0
	Side, rear, and front	0
	Floor	0*

NOTE - For installation on combustible floors, the furnace shall not be installed directly on carpeting, tile, or other combustible material other than wood flooring.

Accessibility and service clearances must take precedence over fire protection clearances.

For installation in a residential garage, the furnace must be installed so that the burner(s) and the ignition source are located no less than 18 inches (457 mm) above the floor. The furnace must be located or protected to avoid physical damage by vehicles. When a furnace is installed in a public garage, hangar, or other building that has a hazardous atmosphere, the furnace must be installed according to recommended good practice requirements and current National Fuel Gas Code or CAN/CGA B149.1 and B149.2 standards.

When the furnace is used with cooling units, it shall be installed in parallel with, or on the upstream side of, cooling units to avoid condensation in the heating compartment. With a parallel flow arrangement, a damper (or other means to control the flow of air) must adequately prevent chilled air from entering the furnace. If the damper is manually operated, it must be equipped to prevent operation of either the heating or the cooling unit, unless it is in the full "HEAT" or "COOL" setting.

When installed, the furnace must be electrically grounded according to local codes. In addition, in the United States, installation must conform with the current National Electric Code, ANSI/NFPA No. 70. The National Electric Code (ANSI/NFPA No. 70) is available from the following address:

National Fire Protection Association
1 Battery March Park
Quincy, MA 02269

In Canada, all electrical wiring and grounding for the unit must be installed according to the current regulations of the Canadian Electrical Code Part I (CSA Standard C22.1) and/or local codes.

Field wiring connections must meet or exceed specifications of type T wire and withstand a maximum temperature rise of 180°F (82°C).

G32 unit must be installed so that electrical components are protected from water.

When the furnace is installed so that supply ducts carry air circulated by the furnace to areas outside of the space containing the furnace, return air shall be handled by a duct(s) sealed to the furnace casing and terminating outside space containing furnace.

WARNING

Product contains fiberglass wool.

Disturbing the insulation in this product during installation, maintenance, or repair will expose you to fiberglass wool dust. Breathing this may cause lung cancer. (Fiberglass wool is known to the State of California to cause cancer.)

Fiberglass wool may also cause respiratory, skin, and eye irritation.

To reduce exposure to this substance or for further information, consult material safety data sheets available from address shown below, or contact your supervisor.

Lennox Industries Inc.

P.O. Box 799900

Dallas, TX 75379-9900

NOTE - G32 series units must not be used as a construction heater during any phase of construction. Very low return air temperatures, harmful vapors and misplacement of the filters will damage the unit and lower its efficiency.

General

The G32Q is an upflow gas furnace. A changeover kit is necessary if the furnace is to be used with L.P. gas. These instructions are intended as a general guide and do not supersede local codes in any way. Consult authorities having jurisdiction before installation.

Shipping and Packing List

- 1 - Assembled G32 furnace
- 1 - 3 inch x 2 inch vent transition piece (-100, -125 units only)
- 1 - Bag assembly containing:
 - 1 - Electrical make-up box
 - 1 - Wiring harness
 - 1 - Snap bushing
 - 2 - Filter clips
 - 1 - Condensate plug
 - 1 - Condensate drain adapter
 - 1 - Brown accessory wire
 - 1 - Green ground wire
 - 4 - Wire nuts
 - 2 - Star washers and screws
 - 8 - Self-tapping screws
 - 1 - Grounding label
 - 1 - Wire tie
 - 3 - Thread-forming screws

Shipping Damage

Check equipment for shipping damage. If you find any damage, immediately contact the last carrier.

⚠ WARNING

Improper installation, adjustment, alteration, service or maintenance can cause property damage, personal injury or loss of life. Installation and service must be performed by a qualified installer, service agency or the gas supplier.

⚠ CAUTION

As with any mechanical equipment, personal injury can result from contact with sharp sheet metal edges. Be careful when you handle this equipment.

Installation - Setting Equipment

Select a location that allows for required clearances listed on the unit rating plate. Also consider gas supply connections, electrical supply, vent connection and installation and service clearances [24 inches (610 mm) at unit front]. The furnace must be level.

NOTE - 1/3 and 1/2 hp blower motors are equipped with either four flexible mounting legs or three flexible legs and one rigid leg. The rigid leg is equipped with a shipping bolt and a flat white plastic washer (rather than the rubber mounting grommet used with a flexible mounting leg). This shipping bolt and flat washer must be removed before the furnace is put into operation. Once the shipping bolt and washer are removed, the rigid leg will not touch the blower housing.

⚠ CAUTION

G32 unit should not be installed in areas normally subject to freezing temperatures.

Return Air Opening Guidelines

⚠ WARNING

Improper installation of unit can result in personal injury or death. Combustion and flue products must never be allowed to enter the return air system or air in the living space. Use sheet metal screws and joint tape to seal return air system to furnace.

In platform installations with furnace return, the furnace should be sealed airtight to the return air plenum. A door must never be used as a portion of the return air duct system. The base must provide a stable support and an airtight seal to the furnace. Allow absolutely no sagging, cracks, gaps, etc. For no reason should return and supply air duct systems ever be connected to or from other heating devices such as a fireplace or stove, etc. Fire, explosion, carbon monoxide poisoning, personal injury and/or property damage could result.

⚠ WARNING

The blower access panel must be securely in place when the blower and burners are operating. Gas fumes, which could contain carbon monoxide, can be drawn into living space resulting in personal injury or death.

Return air can be brought in either side or at the bottom of the unit. Scribe lines show the outline of each side and the bottom return air opening.

Bottom Return Air Applications

If return air is to terminate through the floor under the furnace, a direct, airtight and sealed connection must be made to the bottom of the furnace.

- 1 - Cut opening in floor or platform. Using knockouts provided, cut bottom of base panel. See figure 2.

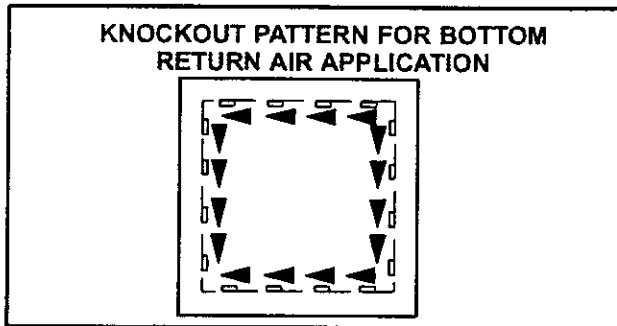

FIGURE 2

- 2 - Bend a flange on return air plenum and lower into floor or platform opening. See figure 3.
- 3 - Position unit over return air opening. Seal unit airtight with return air plenum.

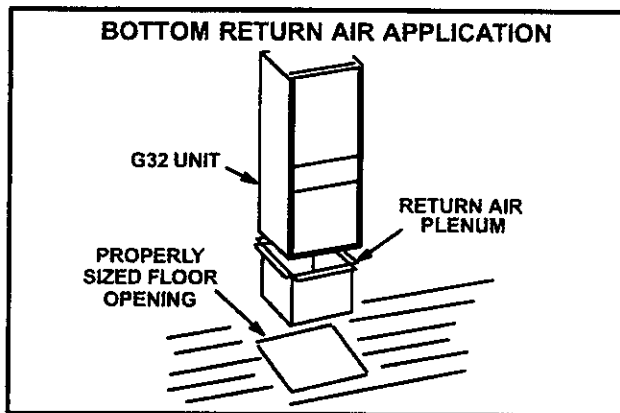

FIGURE 3

NOTE - Be careful not to damage insulation. Check for tight seal.

Side Return Air Applications

For installations where the return air is taken from a return air drop, unit may be installed with return air entry through either the left or right side of the furnace.

For side return air applications, cut furnace cabinet at the dimensions given on page 2. Embossed corners are provided on both cabinet sides for return air opening location.

Filters

This unit is not equipped with a filter or rack. A field-provided high-velocity filter is required for the unit to operate properly. A filter must be in place any time the unit is operating. The unit does include filter clips for installation of a field-provided, internally installed filter. See figure 4.

Bottom Return Air Applications

- 1 - Remove blower access panel.
- 2 - Install filter clips, provided with unit, by slipping folded section of clip on edge of bottom opening. See figure 4.
- 3 - Place filter in bottom of blower compartment beneath rear filter clip. Press down on filter sides. Filter clips flex allowing filter to snap into place.
- 4 - To remove filter, press clip and pull filter up and out.

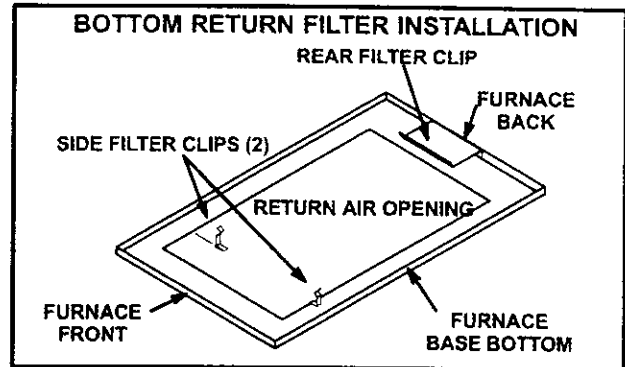

FIGURE 4

Side Return Air Applications

Filter racks are available from Lennox for side return air applications. See figures 5 and 6.

NOTE - The filter door may be shipped in the rack behind the filter. If necessary, remove the filter, retrieve the door and continue with the installation of the rack.

- 1 - Align filter rack opening with the inside edge of the side return opening. Bottom of rack should be approximately 1 inch (25 mm) from the bottom and 3 inches (76 mm) from the front of the unit.
- 2 - Screw filter rack into place with the eight self drill, self tap screws provided. See figure 5.
- 3 - Push filter door pins through the two holes in filter door from the inside of the u-channel. See figure 6.

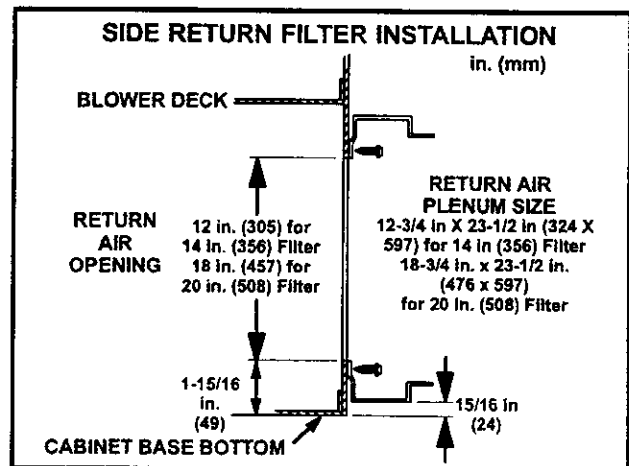

FIGURE 5

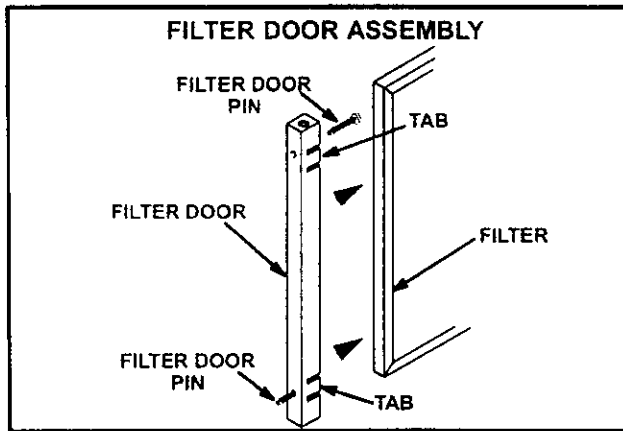

FIGURE 6

- 4 - Position filter door on end of filter so that the thumb tab side of the filter door is away from the furnace. Squeeze thumb tabs to secure filter to door.
- 5 - Guide filter and filter door into the filter rack installed on side of furnace. Push door into filter rack until secure.
- 6 - To remove filter, pull filter door pins until door is released from filter rack.

Duct System

Use industry-approved standards to size and install the supply and return air duct system. This will result in a quiet and low-static system that has uniform air distribution.

Supply Air Plenum

Furnaces installed without a cooling coil require the installation of a removable access panel in the supply air duct. The access panel should be large enough to permit inspection (either by smoke or reflected light) of the heat exchanger for leaks after installation. The furnace access panel must always be in place when the furnace is operating and it must not allow leaks into the supply air duct system.

Return Air Plenum

See dimension illustration on page 2 for proper return air duct size.

NOTE - For bottom return air, return air duct should be secured to the unit using rivets or S-locks. For side return air, secure return air duct to filter rack using screws. When using screws, take care to avoid interference with the filter which may cause improper filtration.

The return air must not be drawn from a room where another gas appliance (ie., a water heater) is installed. Even though this furnace draws its combustion air from outside of the structure, other gas appliances that share a utility room may not. When return air is drawn from a room, a negative pressure is created in the room. If

a gas appliance is operating in a room with negative pressure, the flue products can be pulled back down the vent pipe and into the room. This reverse flow of the flue gas may result in incomplete combustion and the formation of carbon monoxide gas. This toxic gas might then be distributed through the house by the furnace duct system.

Pipe & Fittings Specifications

All pipe, fittings, primer and solvent cement must conform with American National Standard Institute and the American Society for Testing and Materials (ANSI/ASTM) standards. The solvent shall be free flowing and contain no lumps, undissolved particles or any foreign matter that adversely affects the joint strength or chemical resistance of the cement. The cement shall show no gelation, stratification, or separation that cannot be removed by stirring. Refer to table 2 for approved piping and fitting materials.

TABLE 2
PIPING AND FITTINGS SPECIFICATIONS

PIPE & FITTING MATERIAL	ASTM SPECIFICATION
Schedule 40 PVC (Pipe)	D1785
Schedule 40 PVC (Cellular Core Pipe)	F891
Schedule 40 PVC (Fittings)	D2466
Schedule 40 CPVC (Pipe)	F441
Schedule 40 CPVC (Fittings)	F438
SDR-21 PVC (Pipe) or SDR-26 PVC (Pipe)	D2241
SDR-21 CPVC (Pipe) or SDR-26 CPVC (Pipe)	F442
Schedule 40 ABS (Pipe)	D1527
Schedule 40 ABS (Fittings)	D2468
ABS-DWV (Drain Waste & Vent) (Pipe & Fittings)	D2661
PVC-DWV (Drain Waste & Vent - Pipe & Fittings)	D2665

⚠ CAUTION

Solvent cements for plastic pipe are flammable liquids and should be kept away from all sources of ignition. Do not use excessive amounts of solvent cement when making joints. Good ventilation should be maintained to reduce fire hazard and to minimize breathing of solvent vapors. Avoid contact of cement with skin and eyes.

Primers and solvents must meet ASTM specifications. PVC primer is specified in ASTM F 656. Use PVC solvent cement as specified in ASTM D 2564 and ABS solvent cement as specified in ASTM D 2235. Low temperature solvent cement is recommended. Metal or plastic strapping may be used for vent pipe hangers.

Table 3 lists the available exhaust termination kits. All Lennox vent terminations are PVC.

**TABLE 3
TERMINATION KITS**

Lennox Part No.	Kit LB#	Description-Inches (mm)
60G77	LB-49107CE	1-1/2" (38) Concentric Termination Kit
33K97	LB-87942	3" (50.8) Low Pressure Drop Concentric Term. Kit
15F75	LB-49107CC	2" (50.8) Roof Termination Kit
22G44	LB-49107CD	2" (50.8) Wall Assembly Termination Kit
15F74	LB-49107CB	2" (50.8) Wall Ring Kit
44J41	LB-65678A	3" (76.2) Roof Termination Kit
44J40	LB-65701A	3" (76.2) Wall Assembly Termination Kit
30G28	WTK	2" (50.8) Wall Termination Extended Vent
30G79	WTKX	2" (50.8) Wall Termination Extension Riser

When making ABS joints, pieces can be prepared with a cleaner. When joining ABS to PVC materials, use PVC solvent cement. Refer to this procedure as specified in ASTM D3138.

Canada Only -- In some provinces, PVC primer must be purple in color, PVC solvent cement must be grey, ABS solvent cement must be yellow and PVC solvent cement used when joining ABS to PVC must be white.

Vent Piping Guidelines

Pipe used for exhaust and intake lines should be sized according to table 4. Note that maximum length of vent pipe is for one run; either intake or exhaust. Maximum vent length given is not the total length of intake plus exhaust vents.

Each 90° elbow is equivalent to 5 feet (1.52 m) of vent pipe. Two 45° elbows are equivalent to one 90° elbow. One 45° elbow is equal to 2.5 feet (.76 m) of vent pipe.

If intake and exhaust piping runs are not equal in length and number of elbows, the larger diameter pipe must be used for both runs.

NOTE - When a WTKX termination kit (30G79) is installed as part of the intake and exhaust piping, add twelve feet to the equivalent length (the two 2 inch diameter 90° elbows and the 27 inch pipe in the kit).

For 75 kBtuh units, connections are provided for 2 inch diameter venting which should satisfy most venting requirements. No transition pieces are provided or needed for 2 inch venting.

**TABLE 4
VENT PIPE SIZING TABLE FOR G32Q FURNACES
MINIMUM DIAMETER OF INTAKE/EXHAUST PIPE**

Vent Pipe Equivalent Length Max. Feet (Meters)	G32-75 75,000 BTU	G32-100 100,000 BTU	G32-125 125,000 BTU
15 (4.57 m)	2"	2"	2"
20 (6.10 m)	2"	2"	3"
25 (7.62 m)	2"	2"	3"
30 (9.14 m)	2"	3"	3"
40 (12.19 m)	2"	3"	3"
50 (15.24 m)	2"	3"	3"
55 (16.76 m)	2"	3"	3"
60 (18.29 m)	3"	3"	3"
70 (21.34 m)	3"	3"	3"
80 (24.38 m)	3"	3"	3"
90 (27.43 m)	3"	3"	3"
100 (30.48 m)	3"	3"	3"
110 (33.53 m)	3"	3"	3"
120 (36.58 m)	3"	3"	3"
130 (39.62 m)	3"	3"	--

NOTE - Min. pipe for G32-75 is 5 feet and 2 elbows of 2 inch diameter pipe.

NOTE - Min. pipe for G32-100 is 5 feet and 2 elbows of 2 inch diameter pipe.

NOTE - Min. pipe for G32-125 is 5 feet and 2 elbows of 2 inch diameter pipe.

For -100 and -125 kBtuh units, the intake connection is sized for 3 inch diameter pipe. The exhaust connection has a 2 inch nipple. A pipe transition piece is shipped with the unit to connect to 3 inch pipe. See figure 7 for 2 inch and 3 inch venting applications.

Most venting applications will require 3 inch venting for proper unit operation. For no reason should the intake and exhaust pipe be different diameter pipes. Regardless of the diameter of pipe used, the standard roof and wall terminations described in *Intake and Exhaust Piping Terminations* section should be used. Exhaust piping must terminate with 1-1/2 inch pipe for 1-1/2 inch or 2 inch venting and 2 inch pipe for 3 inch venting.

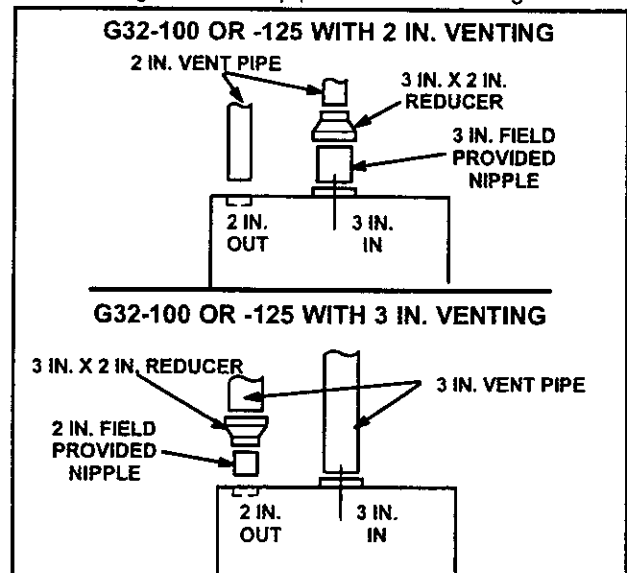

FIGURE 7

Joint Cementing Procedure

All cementing of joints should be done according to the specifications outlined in ASTM D 2855.

WARNING

DANGER OF EXPLOSION! Fumes from PVC glue may ignite during system check. Disconnect wire from pressure switch terminal before 115 volt power is applied to unit. Reconnect wire after two minutes of combustion air inducer operation.

- 1 - Measure and cut vent pipe to desired length.
- 2 - Deburr and chamfer end of pipe, removing any ridges or rough edges. If end is not chamfered, edge of pipe may remove cement from fitting socket and result in a leaking joint.
- 3 - Clean and dry surfaces to be joined.
- 4 - Test fit joint and mark depth of fitting on outside of pipe.
- 5 - Uniformly apply liberal coat of PVC primer for PVC or ABS cleaner for ABS to inside socket surface of fitting and male end of pipe to depth of fitting socket.
- 6 - Promptly apply solvent cement to end of pipe and inside socket surface of fitting. Cement should be applied lightly but uniformly to inside of socket. Take care to keep excess cement out of socket. Apply second coat to end of pipe.

NOTE - Time is critical at this stage. Do not allow primer to dry before applying cement.

- 7 - Immediately after applying last coat of cement to pipe, and while both inside socket surface and end of pipe are wet with cement, forcefully insert end of pipe into socket until it bottoms out. Turn pipe 1/4 turn during assembly (but not after pipe is fully inserted) to distribute cement evenly.

NOTE - Assembly should be completed within 20 seconds after last application of cement. Hammer blows should not be used when inserting pipe.

- 8 - After assembly, wipe excess cement from pipe at end of fitting socket. A properly made joint will show a bead around its entire perimeter. Any gaps may indicate a defective assembly due to insufficient solvent.
- 9 - Handle joints carefully until completely set.

Venting Practices

The thickness of construction through which vent/air intake pipes may be installed is a minimum of 3 inches (76 mm) and a maximum of 24 inches (610 mm). If a G32 furnace replaces a furnace which was commonly vented with another gas appliance, the size of the existing vent pipe for that gas appliance must be checked. Without the heat of the original furnace flue products, the existing vent pipe is probably oversized for the single water heater or other appliance. The vent should be checked for proper draw with the remaining appliance.

Intake Piping

- 1 - Cement intake piping in slip connector located at top of unit.
- 2 - Route piping to outside of structure. Continue with installation following instructions given in exhaust and intake piping termination section.

WARNING

Insufficient combustion air can cause headaches, nausea, dizziness or asphyxiation. It will also cause excess water in the heat exchanger resulting in rusting and premature heat exchanger failure. Excessive exposure to contaminated combustion air will result in safety and performance related problems. Avoid exposure to the following substances in the combustion air supply:

- Permanent wave solutions
- Chlorinated waxes and cleaners
- Chlorine base swimming pool chemicals
- Water softening chemicals
- De-icing salts or chemicals
- Carbon tetrachloride
- Halogen type refrigerants
- Cleaning solvents (such as perchloroethylene)
- Printing inks, paint removers, varnishes, etc.
- Hydrochloric acid
- Cements and glues
- Antistatic fabric softeners for clothes dryers
- Masonry acid washing materials

Exhaust Piping

- 1 - Cement exhaust piping into flue collar socket located on the left side of the top cap.
- 2 - All horizontal runs of exhaust pipe must slope back toward the unit. A minimum of 1/4 inch (6 mm) drop for each 12 inches (305 mm) of horizontal run is mandatory for drainage. Horizontal runs of exhaust piping must be supported every 5 feet (1.52 m) using hangers.

NOTE - Exhaust piping should be checked carefully to make sure there are no sags or low spots.

NOTE - Exhaust piping must be insulated with 1/2 inch (13 mm) Armaflex or equivalent when run through unheated space. Do not leave any area of exhaust pipe open to outside air; exterior exhaust must be insulated with 1/2 inch (13 mm) Armaflex or equivalent.

⚠ CAUTION

Do not discharge exhaust into an existing stack or stack that also serves another gas appliance. If vertical discharge through an existing unused stack is required, insert PVC pipe inside the stack until the end is even with the top or outlet end of the metal stack.

⚠ CAUTION

The exhaust vent pipe operates under positive pressure and must be completely sealed to prevent leakage of combustion products into the living space.

Removal of Unit from Common Venting System

In the event that an existing furnace is removed from a venting system commonly run with separate gas appliances, the venting system may be too large to properly vent the remaining attached appliances. The following test should be conducted while all appliances (both in operation and those not in operation) are connected to the common venting system. If the venting system has been installed improperly, corrections must be made as outlined in the previous section.

- 1 - Seal any unused openings in the common venting system.
- 2 - Visually inspect the venting system for proper size and horizontal pitch and determine there is no blockage or restriction, leakage, corrosion or other deficiencies which could cause an unsafe condition.
- 3 - To the extent that it is practical, close all building doors and windows, and all doors between the space in which the appliances remaining connected to the common venting system are located and other spaces of the building. Turn on clothes dryers and any appliances not connected to the common venting system. Turn on any exhaust fans, such as range hoods and bathroom exhausts, so they will operate at maximum speed. Do not operate a summer exhaust fan. Close fireplace dampers.
- 4 - Follow the lighting instructions. Place the appliance being inspected in operation. Adjust thermostat so appliance will operate continuously.

- 5 - Test for spillage at the draft hood relief opening after 5 minutes of main burner operation. Use the flame of match or candle, or smoke from a cigarette or cigar, or a draft gauge.
- 6 - After determining that each appliance remaining connected to the common venting system properly vents when tested as indicated in step 3, return doors, windows, exhaust fans, fireplace dampers and any other gas-burning appliance to their previous condition of use.
- 7 - If improper venting is observed during any of the above tests, the common venting system must be corrected. The common venting system should be resized to approach the minimum size as determined by using the appropriate tables in appendix G in the current standards of the National Fuel Gas Code ANSI Z223-1 in the USA, and the appropriate Category 1 Natural Gas appliances venting sizing tables in the current standard of the CAN/CGA-B149.1 in the Natural Gas Installation Code in Canada.

Intake and Exhaust Piping Terminations

Intake and exhaust pipes may be routed either horizontally through an outside wall or vertically through the roof. In attic or closet installations, vertical termination through the roof is preferred. Figures 8 through 20 show typical terminations.

- 1 - Use recommended piping materials for both intake and exhaust piping.
- 2 - Secure all joints, including drain leg, gas tight using approved cement.
- 3 - Piping diameters should be determined according to length of pipe run. See table 4. Locate intake piping upwind (prevailing wind) from exhaust piping. To avoid recirculation of exhaust gas on roof terminations, end of exhaust pipe must be higher than intake pipe.
Exhaust and intake exits must be in same pressure zone. Do not exit one through the roof and one on the side. Also, do not exit the intake on one side and the exhaust on another side of the house or structure.
- 4 - Intake and exhaust pipes should be placed as close together as possible at termination end (refer to illustrations). Maximum separation is 3 inches (76 mm) on roof terminations and 6 inches (152 mm) on side wall terminations.
- 5 - Exhaust piping must terminate straight out or up as shown. In rooftop applications, a 2 inch X 1-1/2 inch reducer for 2 inch venting, 3 inch x 2 inch reducer for 3 inch venting must be used on the exhaust piping at the point where it exits the structure to improve the velocity of exhaust away from the intake piping.

On roof terminations, the intake piping should terminate straight down using two 90° elbows. See figure 8.

⚠ IMPORTANT
Do not use screens or perforated metal in intake and exhaust terminations. Doing so will cause freeze-ups and may block the terminations.

NOTE - If winter design temperature is below 32°F (0°C), exhaust piping must be insulated with 1/2 inch (13 mm) Armaflex or equivalent when run through unheated space. Do not leave any surface area of exhaust pipe open to outside air; exterior exhaust pipe must be insulated with 1/2 inch (13 mm) Armaflex or equivalent. In extreme cold climate areas, 3/4 inch (19 mm) Armaflex or equivalent is recommended. Insulation on outside runs of exhaust pipe must be painted or wrapped to protect insulation from deterioration.

NOTE - During extremely cold temperatures, below approximately 20°F (6.67°C), units with long runs of vent pipe through unconditioned space, even when insulated, may form ice in the exhaust termination that prevents the unit from operating properly. Longer run times of at least 5 minutes will alleviate most icing problems. Also, a heating cable may be installed on exhaust piping and termination to prevent freeze-ups. Heating cable installation kit is available from Lennox. See Condensate Piping section for part numbers.

NOTE - Care must be taken to avoid recirculation of exhaust back into intake pipe.

6 - On field-supplied terminations for side wall exits, exhaust piping should extend a maximum of 12 inches (305 mm) beyond the outside wall. Intake piping should be as short as possible. See figure 10.

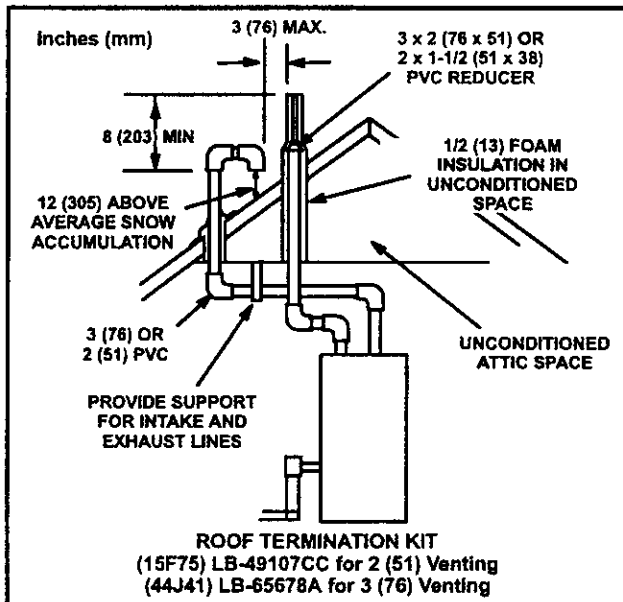

FIGURE 8

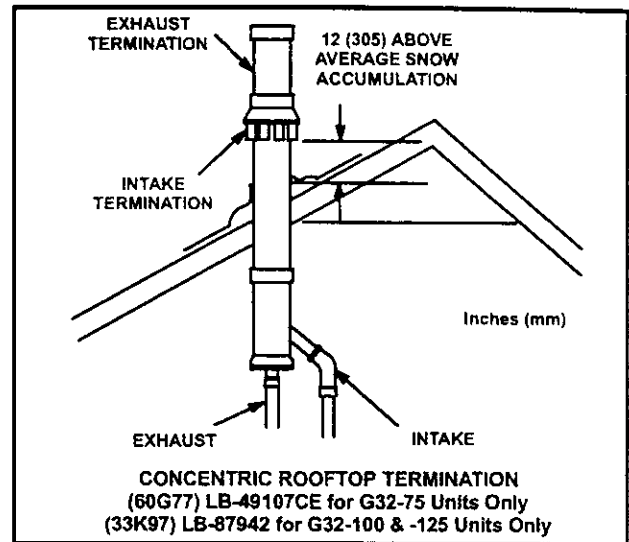

FIGURE 9

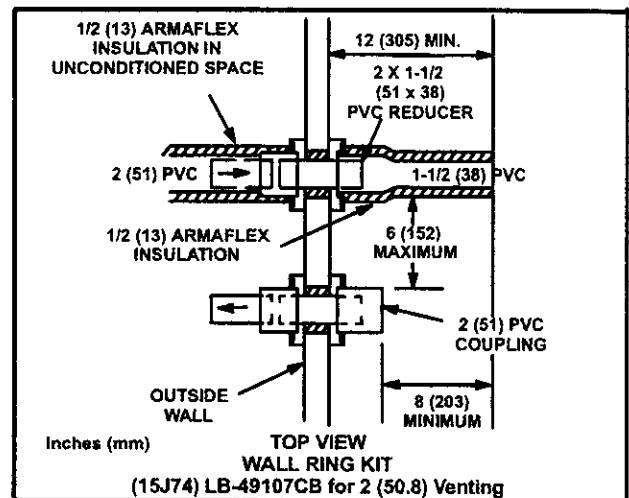

FIGURE 10

7 - On field-supplied terminations, a minimum separation distance between the end of the exhaust pipe and the end of the intake pipe is 8 inches (203 mm).

8 - If intake and exhaust piping must be run up a side wall to position above snow accumulation or other obstructions, the piping must be supported every 3 feet (.91 m) as shown in figure 15. Refer to figures 13 and 14 for proper piping method. WTK wall termination kit must be extended for use in this application. See figure 18 or use kit WTKX shown in figure 19. When exhaust and intake piping must be run up an outside wall, the exhaust piping is reduced to 1-1/2 inches (38 mm) after the final elbow. The intake piping may be equipped with a 90° elbow turndown. Using 90° turndown will add 5 feet (1.5 m) to the equivalent length of the pipe.

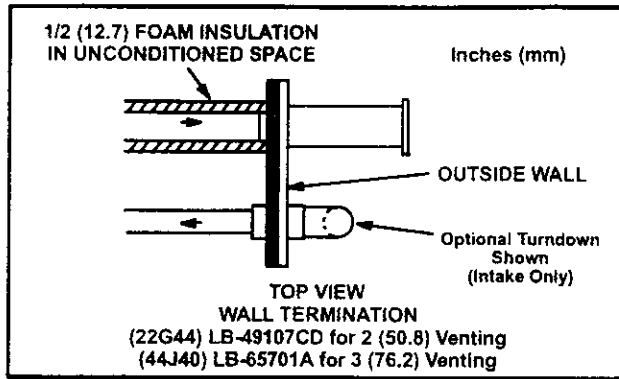

FIGURE 11

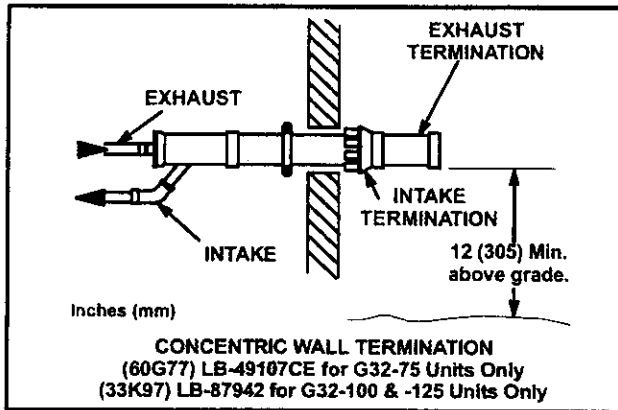

FIGURE 12

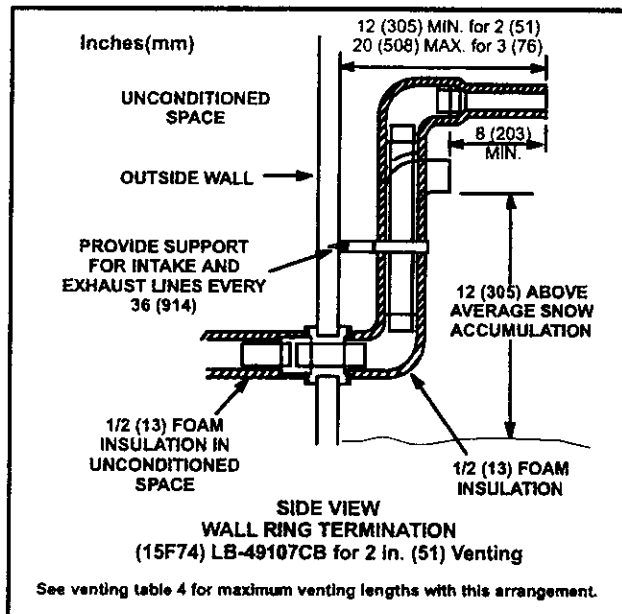

FIGURE 13

- 9 - Position termination ends so they are free from any obstructions and above the level of snow accumulation (where applicable). Termination ends must be a minimum of 12 inches (305 mm) above grade level. Do not point into window wells, stairwells, alcoves,

courtyard areas or other recessed areas. Do not position termination ends directly below roof eaves or above a walkway. Since the G32 is a certified direct vent, Category IV gas furnace, the location of the termination is limited by local building codes. In the absence of local codes, refer to the current National Fuel Gas Code ANSI Z223-1 in USA, and current standard CAN/CGA-B149.1 of the Natural Gas Installation Instructions in Canada for details. The termination should be at least 12 inches (305 mm) from any opening through which flue products could enter the building.

When horizontally vented, minimum clearance for termination from electric meters, gas meters, regulators and relief equipment is 4 feet (1.2 m) for US installations. Refer to the current CAN/CGA-B149.1 for installations in Canada or with authorities having local jurisdiction.

At vent termination, care must be taken to maintain protective coatings over building materials (prolonged exposure to exhaust condensate can destroy protective coatings). It is recommended that the exhaust outlet not be located within 6 feet (1.8 m) of a condensing unit because the condensate can damage the painted coating.

⚠ IMPORTANT

Combustion air inlet and exhaust outlet should not be located within 6 feet (1.8 m) of dryer vent or combustion air inlet or outlet of another appliance. Piping should not exit less than 3 feet (.91 m) from opening into another building.

⚠ IMPORTANT

For Canadian Installations Only:
In accordance to CAN/CGA-B149.1 and .2, the minimum allowed distance between the combustion air inlet and the exhaust outlet of other appliances shall not be less than 12 inches (305 mm).

- 10 - Suspend piping using hangers at a minimum of every 5 feet (1.52 m) for schedule 40 PVC and every 3 feet (.91 m) for ABS-DWV, PVC-DWV, SDR-21 PVC, and SDR-26 PVC piping. A suitable hanger can be fabricated by using metal or plastic strapping or a large wire tie.
- 11 - In areas where piping penetrates joists or interior walls, hole must be large enough to allow clearance on all sides of pipe as it passes through the center of the hole.
- 12 - Isolate piping at the point where it exits the outside wall or roof.

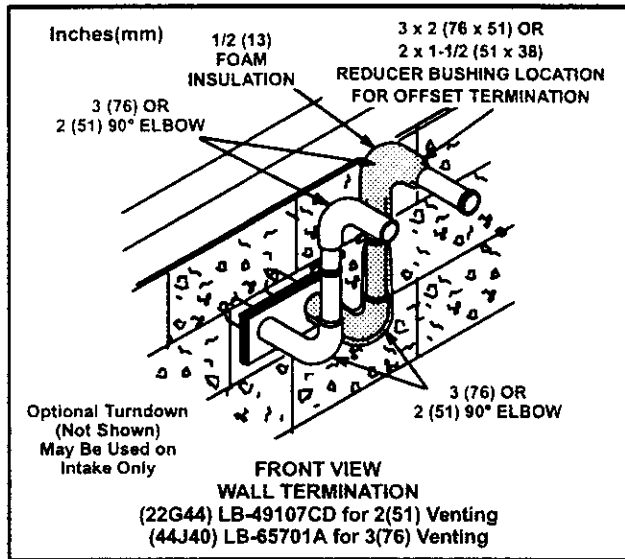

FIGURE 14

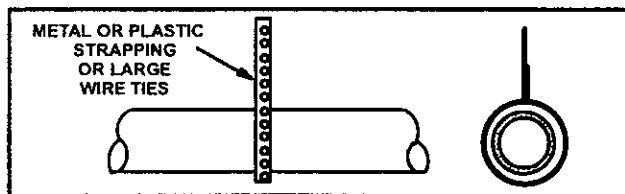

FIGURE 15

- 13 - When furnace is installed in a residence where unit is shut down for an extended period of time, such as a vacation home, make provisions for draining condensate collection trap and lines.
- 14 - Based on the recommendation of the manufacturer, a multiple furnace installation may use a group of up to four termination kits WTK assembled together horizontally, as shown in figure 17.

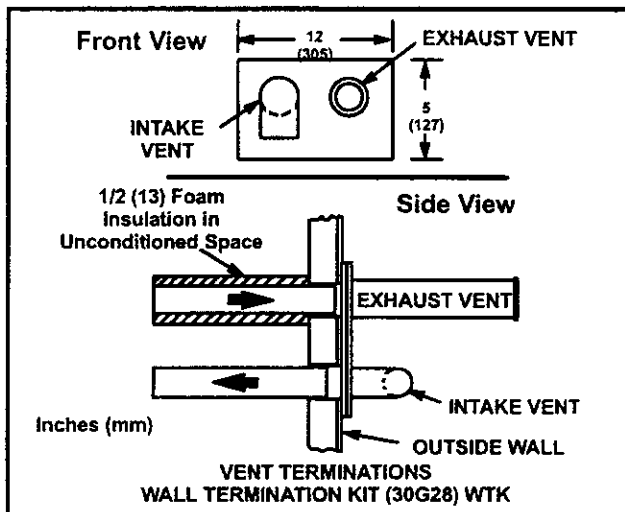

FIGURE 16

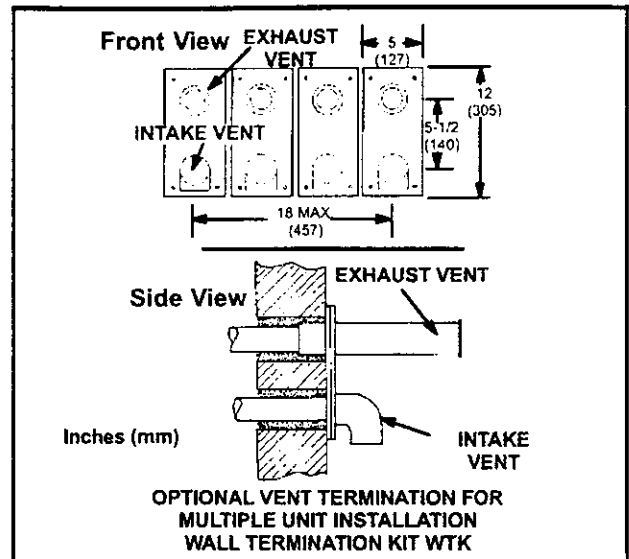

FIGURE 17

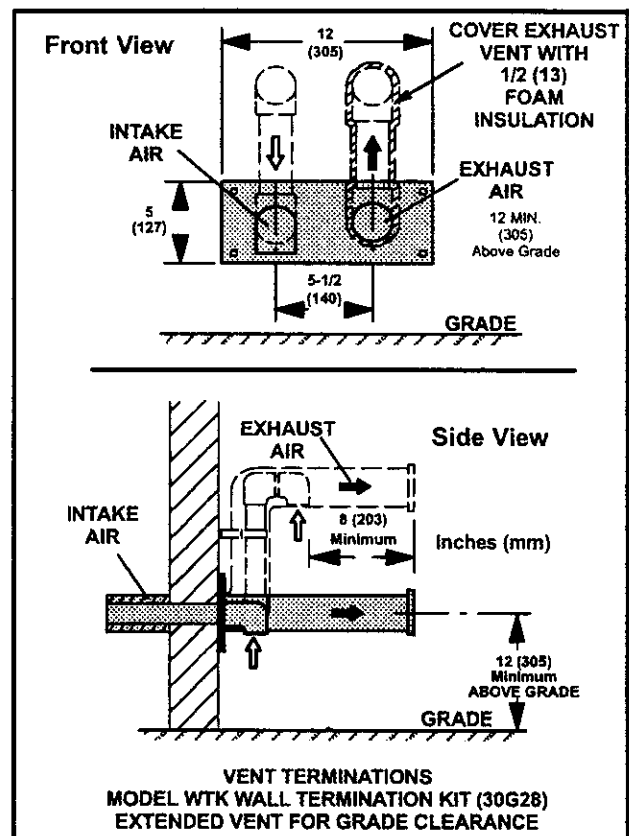

FIGURE 18

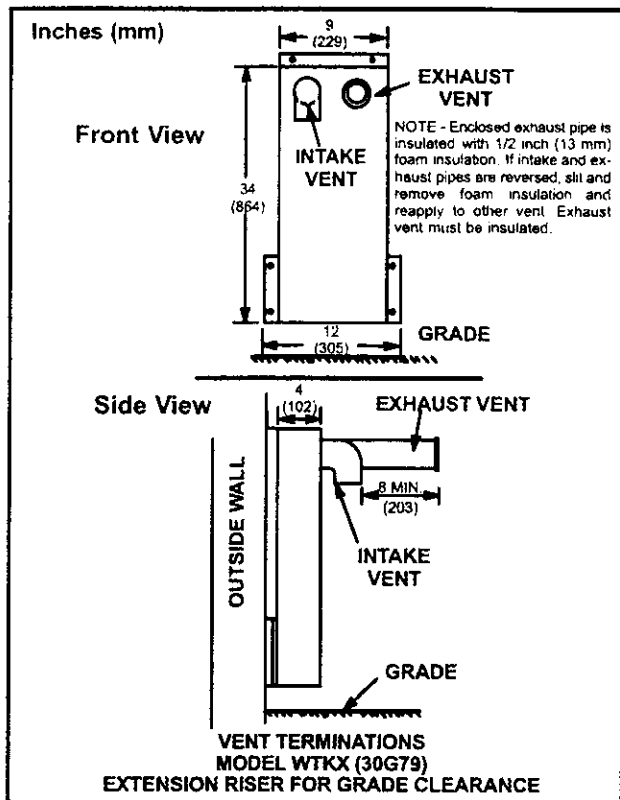

FIGURE 19

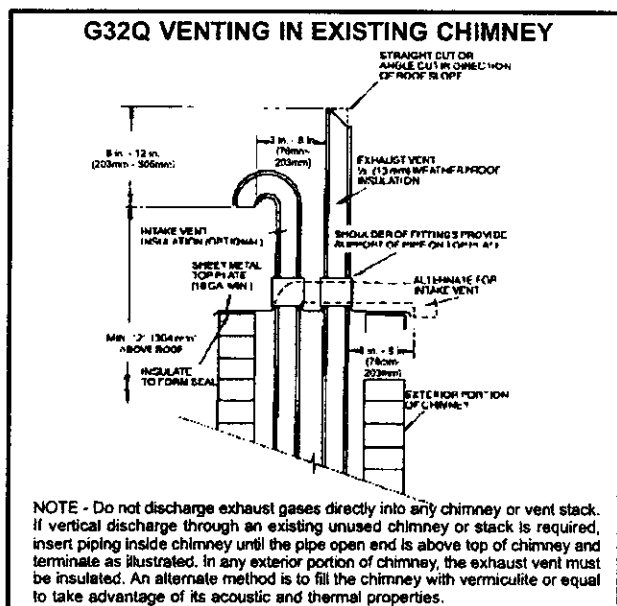

FIGURE 20

Condensate Piping

This unit is designed for either right- or left-side exit of condensate piping. Route the condensate drainline only within the conditioned space: this prevents possible

freezing of the condensate, which would block the drainline. Use an electric heat cable if you route the condensate line through unconditioned areas.

CAUTION

Do not use copper tubing or existing copper condensate lines for drain line.

- 1 - Determine which side condensate will exit the unit.
- 2 - Connect 1/2 inch (13 mm) plastic pipe plug (provided) in the unused end of the condensate trap. Install plug so that it is sealed water tight yet able to be removed. Do not permanently seal the connection. Teflon tape is recommended to seal joint. See figure 21.

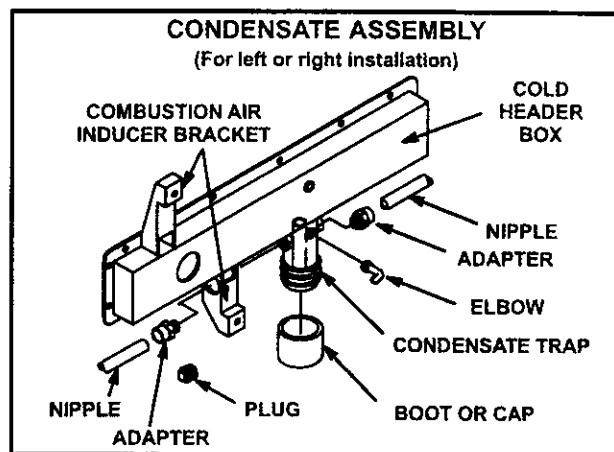

FIGURE 21

- 3 - Use the provided condensate drain adapter (3/4" x 1/2") and a field-provided nipple to carry drainage outside the cabinet. If a field substitute is needed, 1/2 inch CPVC x 1/2 inch MPT adapter and 1/2 inch CPVC is acceptable for use.
- 4 - Glue nipple to the adapter using the procedures outlined in the "Joint Cementing Procedures" section. The nipple/adapter assembly should be connected in a non-permanent manner and must be water tight. Teflon tape is recommended to seal the joint.

For Right-Hand Side Condensate Exit:

Install the nipple/adapter assembly from the outside of the cabinet and insert the adapter into the threaded opening in the condensate trap.

For Left-Hand Side Condensate Exit:

Insert nipple/adapter assembly from the left hand side of the cabinet and through the combustion air inducer mounting structure into the threaded opening in the condensate trap.

- 5 - Connect field-supplied plumbing to nipple and route to open drain. Plumbing should be vented to a point higher than the condensing coil. See figure 22.

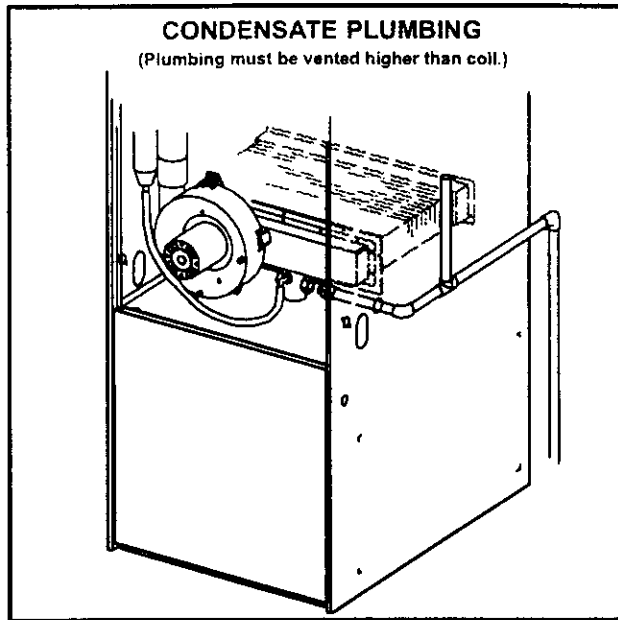

FIGURE 22

- 6 - Connect condensate drain line (1/2 inch [13 mm] SDR 11 plastic pipe or tubing) to condensate connection on condensate trap assembly and route to open drain. Condensate line must be sloped downward away from drip leg to drain. If the drain level is above condensate outlet, use a condensate pump to pump the condensate to the higher level. Condensate drain line should be routed within the conditioned space to avoid freezing of condensate and blockage of drain line. If this is not possible, a heat cable kit may be used on the condensate line. Heating cable kit is available from Lennox in various lengths; 6 feet (1.8 m) - kit no. 18K48; 24 feet (7.3 m) - kit no. 18K49; and 50 feet (15.2 m) - kit no. 18K50.

Gas Piping

⚠ CAUTION

If a flexible gas connector is required or allowed by the authority that has jurisdiction, black iron pipe shall be installed at the gas valve and extend outside the furnace cabinet.

- 1 - Gas piping may be routed into the unit through either the left- or right-hand side. Supply piping enters into the gas valve from the bottom of the valve as shown in figure 24.
- 2 - When connecting the gas supply, factors such as length of run, number of fittings and furnace rating must be considered to avoid excessive pressure drop. Table 5 lists recommended pipe sizes for typical applications.

NOTE - Use two wrenches when connecting gas piping to avoid transferring torque to the manifold.

- 3 - The gas piping must not run in or through air ducts, clothes chutes, gas vents or chimneys, dumb waiters or elevator shafts. Center gas line through piping hole. Gas line should not touch side of unit. When left-hand gas plumbing is required, gas line should be installed in the lower half of knockout so that piping will clear combustion air inducer. See figure 24.
- 4 - The piping should be sloped 1/4 inch (6.4 mm) per 15 feet (4.57 m) upward toward the meter from the furnace. The piping must be supported at proper intervals [every 8 to 10 feet (2.44 to 3.01 m) using suitable hangers or straps. A drip leg should be installed in vertical pipe runs to the unit.
- 5 - Some local codes may require installation of a manual main shut-off valve and union (furnished by the installer) external to the unit. Union must be of the ground joint type.

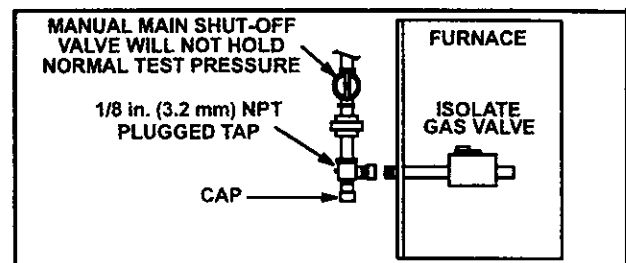

FIGURE 23

NOTE - Install a 1/8 inch NPT plugged tap in the field piping upstream of the gas supply connection to the unit. The tap must be accessible for test gauge connection. See figure 24.

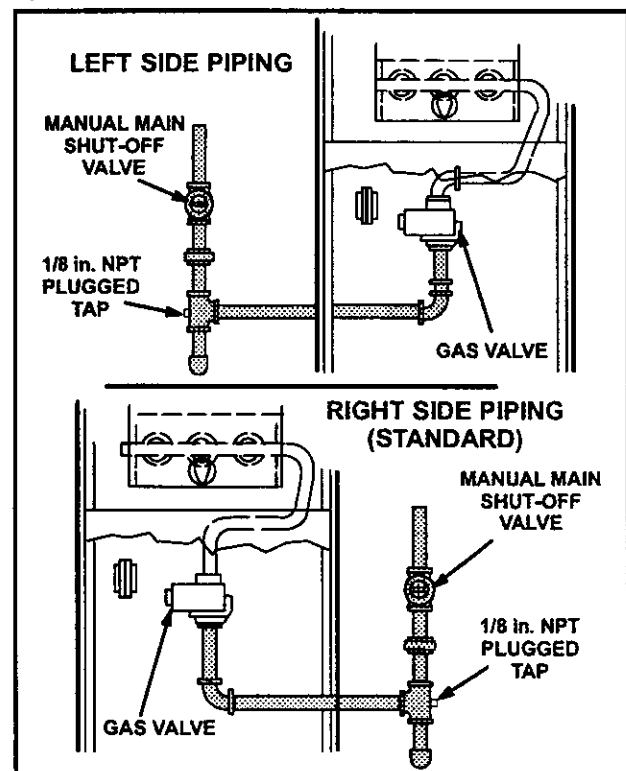

FIGURE 24

**TABLE 5
GAS PIPE CAPACITY - ft.³/hr (m³/hr)**

Nominal Iron Pipe Size -Inches(mm)	Internal Diameter -Inches(mm)	Length of Pipe-Feet (m)									
		10 (3.048)	20 (6.096)	30 (9.144)	40 (12.192)	50 (15.240)	60 (18.288)	70 (21.336)	80 (24.384)	90 (27.432)	100 (30.480)
1/4 (6.35)	.364 (9.246)	43 (1.13)	29 (.82)	24 (.68)	20 (.57)	18 (.51)	16 (.45)	15 (.42)	14 (.40)	13 (.37)	12 (.34)
3/8 (9.53)	.493 (12.522)	95 (2.69)	65 (1.84)	52 (1.47)	45 (1.27)	40 (1.13)	36 (1.02)	33 (.73)	31 (.88)	29 (.82)	27 (.76)
1/2 (12.7)	.622 (17.799)	175 (4.96)	120 (3.40)	97 (2.75)	82 (2.32)	73 (2.07)	66 (1.87)	61 (1.73)	57 (1.61)	53 (1.50)	50 (1.42)
3/4 (19.05)	.824 (20.930)	360 (10.19)	250 (7.08)	200 (5.66)	170 (4.81)	151 (4.28)	138 (3.91)	125 (3.54)	118 (3.34)	110 (3.11)	103 (2.92)
1 (25.4)	1.049 (26.645)	680 (19.25)	465 (13.17)	375 (10.62)	320 (9.06)	285 (8.07)	260 (7.36)	240 (6.80)	220 (6.23)	205 (5.80)	195 (5.52)
1-1/4 (31.75)	1.380 (35.052)	1400 (39.64)	950 (26.90)	770 (21.80)	660 (18.69)	580 (16.42)	530 (15.01)	490 (13.87)	460 (13.03)	430 (12.18)	400 (11.33)
1-1/2 (38.1)	1.610 (40.894)	2100 (59.46)	460 (41.34)	1180 (33.41)	990 (28.03)	900 (25.48)	810 (22.94)	750 (21.24)	690 (19.54)	650 (18.41)	620 (17.56)
2 (50.8)	2.067 (52.502)	3950 (111.85)	2750 (77.87)	2200 (62.30)	1900 (53.80)	1680 (47.57)	1520 (43.04)	1400 (39.64)	1300 (36.81)	1220 (34.55)	1150 (32.56)
2-1/2 (63.5)	2.469 (67.713)	6300 (178.39)	4350 (123.17)	3520 (99.67)	3000 (84.95)	2650 (75.04)	2400 (67.96)	2250 (63.71)	2050 (58.05)	1950 (55.22)	1850 (52.38)
3 (76.2)	3.068 (77.927)	11000 (311.48)	7700 (218.03)	6250 (176.98)	5300 (150.07)	4750 (134.50)	4300 (121.76)	3900 (110.43)	3700 (104.77)	3450 (97.69)	3250 (92.03)
4 (101.6)	4.026 (102.260)	23000 (651.27)	15800 (447.39)	12800 (362.44)	10900 (308.64)	9700 (274.67)	8800 (249.18)	8100 (229.36)	7500 (212.37)	7200 (203.88)	6700 (189.72)

NOTE - Capacity given in cubic feet (m³) of gas per hour and based on 0.60 specific gravity gas.

Leak Check

After gas piping is completed, carefully check all piping connections (factory- and field-installed) for gas leaks. Use a leak detecting solution or other preferred means.

⚠ CAUTION

Some soaps used for leak detection are corrosive to certain metals. Carefully rinse piping thoroughly after leak test has been completed. Do not use matches, candles, flame or other sources of ignition to check for gas leaks.

⚠ IMPORTANT

The furnace must be isolated from the gas supply piping system by closing its individual manual shut-off valve during any pressure testing of the gas supply piping system at test pressures equal to or less than 1/2 psig (3.45 kPa). See figure 23.

The furnace and its individual shut-off valve must be disconnected from the gas supply piping system during any pressure testing of the system at test pressures greater than 1/2 psig (3.45 kPa).

Electrical

A field make-up box is provided for line voltage wiring. Line voltage wiring to unit is done through the J69 jack from the field make-up box to plug P69 from the control box. See figures 26 and 27 for make-up box installation.

Figure 28 shows thermostat designations for identification purposes. Refer to figure 29 for control box arrangement, figure 30 for a detail of the Surelight™ integrated control, figure 32 for point-to-point field wiring and figure 33 for schematic wiring diagram and troubleshooting.

**ELECTROSTATIC DISCHARGE (ESD)
Precautions and Procedures**

⚠ CAUTION

Electrostatic discharge can affect electronic components. Take precautions during furnace installation and service to protect the furnace's electronic controls. Precautions will help to avoid control exposure to electrostatic discharge by putting the furnace, the control and the technician at the same electrostatic potential. Neutralize electrostatic charge by touching hand and all tools on an unpainted unit surface, such as the gas valve or blower deck, before performing any service procedure.

- 1 - Install field make-up box on either side, inside or out of the cabinet. Knockouts are provided in box and cabinet to run wiring. See figures 26 and 27.
- 2 - Remove cap from knockout in blower deck on the same side as the installed make-up box.

⚠ IMPORTANT

Ignition control will not operate unless unit is properly grounded. 120V supply must be installed with correct polarity.

- Electrically ground unit in accordance with local codes or, in the absence of local codes, in accordance with the current National Electric Code (ANSI/NFPA No. 70) and in Canada with the current Canadian Electric Code part 1 (CSA standard C22.1). The ground wire is provided in the field make-up box.

To ensure proper grounding of the furnace, two star washers are included in the electrical make-up box bag assembly. Place the star washer on securing screw before installing the make-up box. Make sure the star washer breaks the paint on the cabinet so that the washer is touching metal. Unit is not properly grounded if paint has not been removed by star washer.

- An optional 120 volt accessory wire is provided with G32 units. Install the brown accessory wire into J69 jack plug by inserting the pin of the brown wire into the open socket of the jack. See figure 25. Any accessory rated up to 4 amps can be connected to this wire. Connect the neutral leg of the accessory to the neutral white wire in the make-up box. The accessory terminal is energized whenever the blower is in operation.

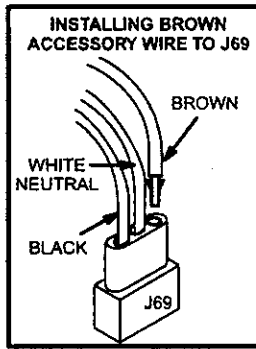

FIGURE 25

- Insert the three-pin (P69) plug from the control box into the knockout provided in the blower deck.
- Connect jack (J69) from make-up box to jack plug in blower deck.
- Select wire size according to the blower motor amps.
- Snaphole bushing is provided for the wiring entry hole in the cabinet. A snaphole plug is provided to seal the unused wire entry hole

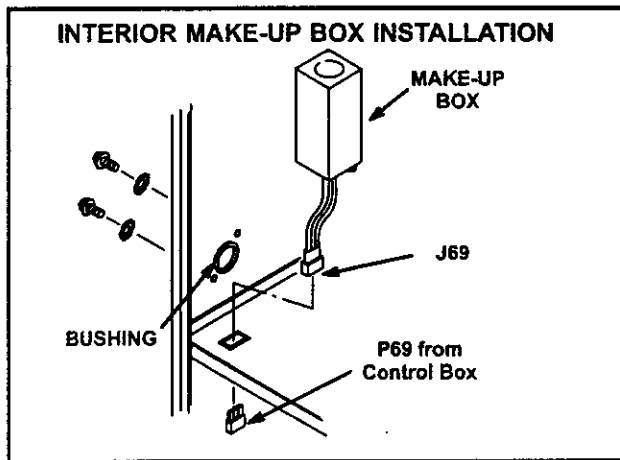

FIGURE 26

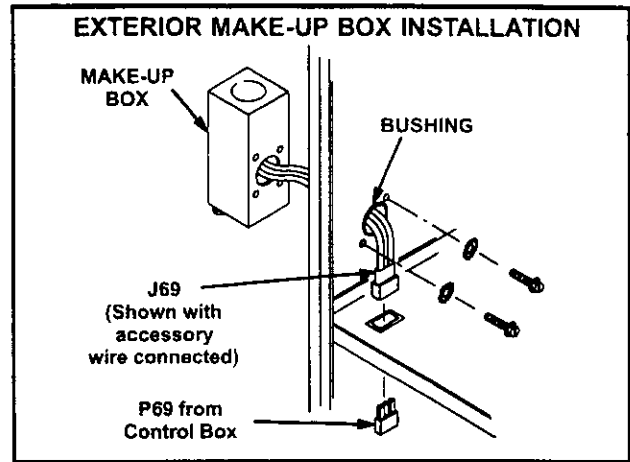

FIGURE 27

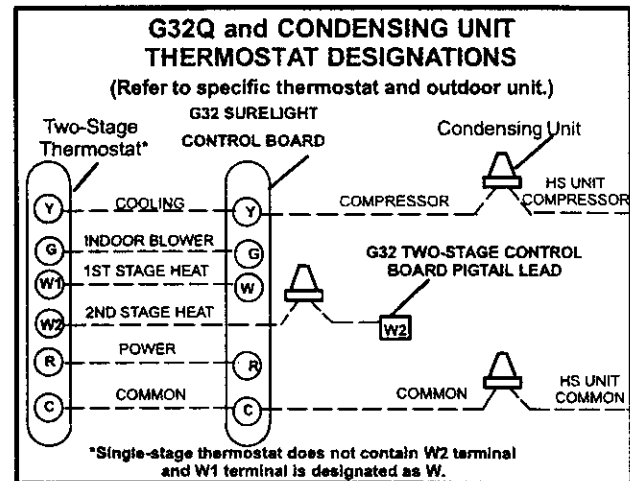

FIGURE 28

- Install room thermostat according to instructions provided with thermostat. See figure 28 for thermostat designations. If furnace is being used with heat pump refer to FM21 installation instruction.

NOTE - W2 thermostat connection (pigtail) must be made at two-speed control board. SureLight™ board is not equipped with a W2 terminal.

- Install a separate disconnect switch near the unit so power can be turned off for servicing.
- Complete wiring connections to equipment using wiring diagrams provided with unit and in figures 32 and 33. Use 18-gauge wire or larger for thermostat connections.
- The two-stage relay board controls first- and second-stage furnace operation providing maximum comfort and efficiency. The furnace may be controlled by either a single- or two-stage room thermostat.
- The blower will run on continuous fan speed with the low speed tap connected to the (ACB LOW) 120 volt terminal and the thermostat set to "FAN ON" when there is no call for heating or cooling.

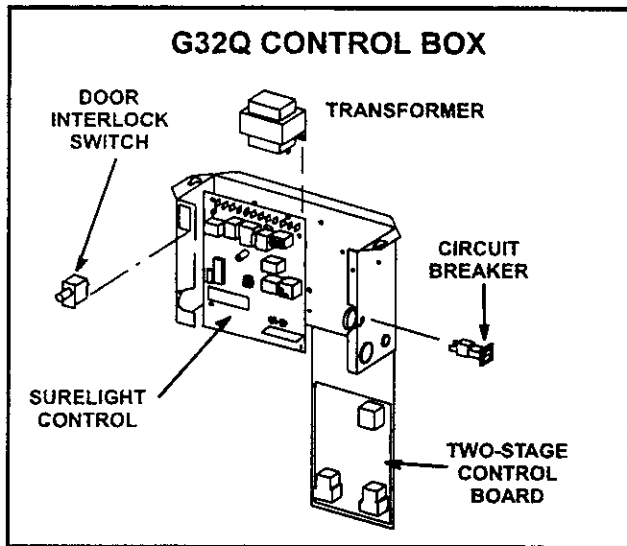

FIGURE 29

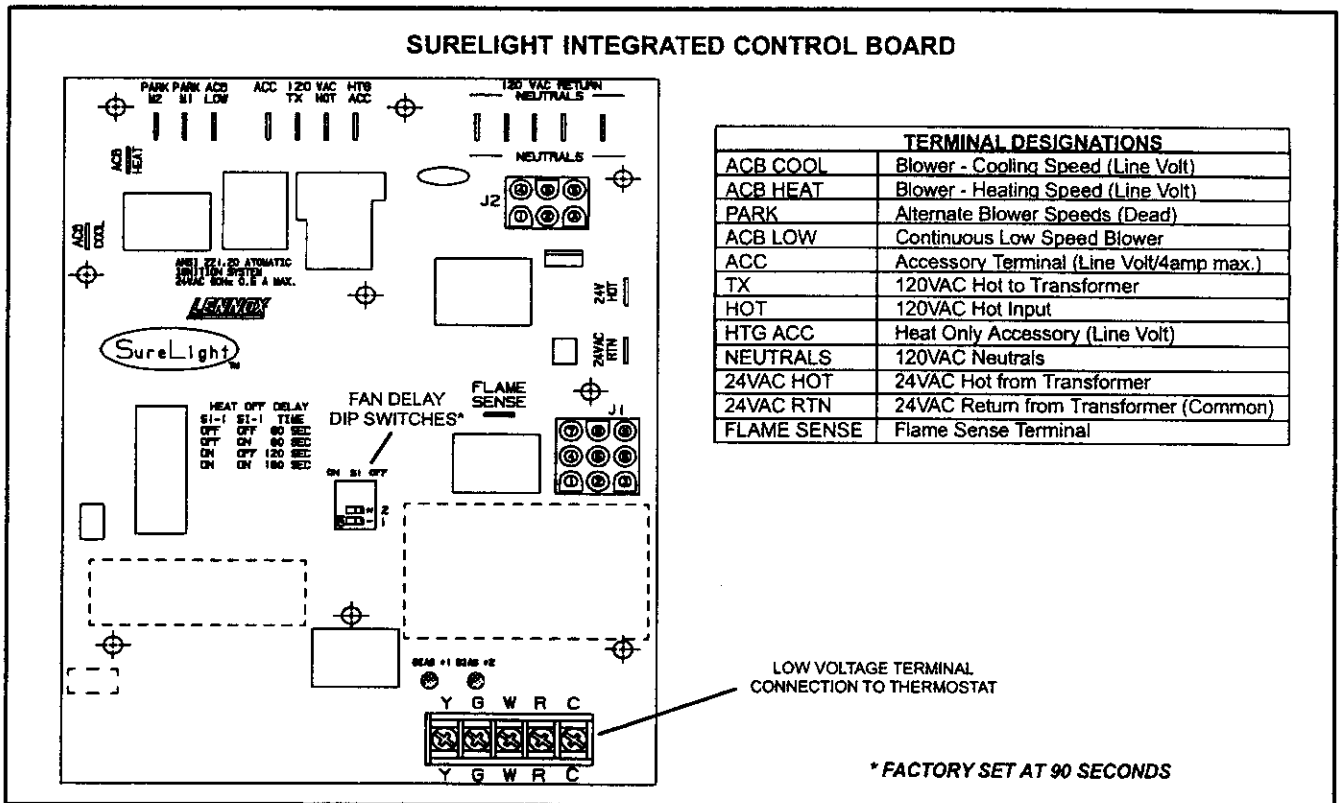

FIGURE 30

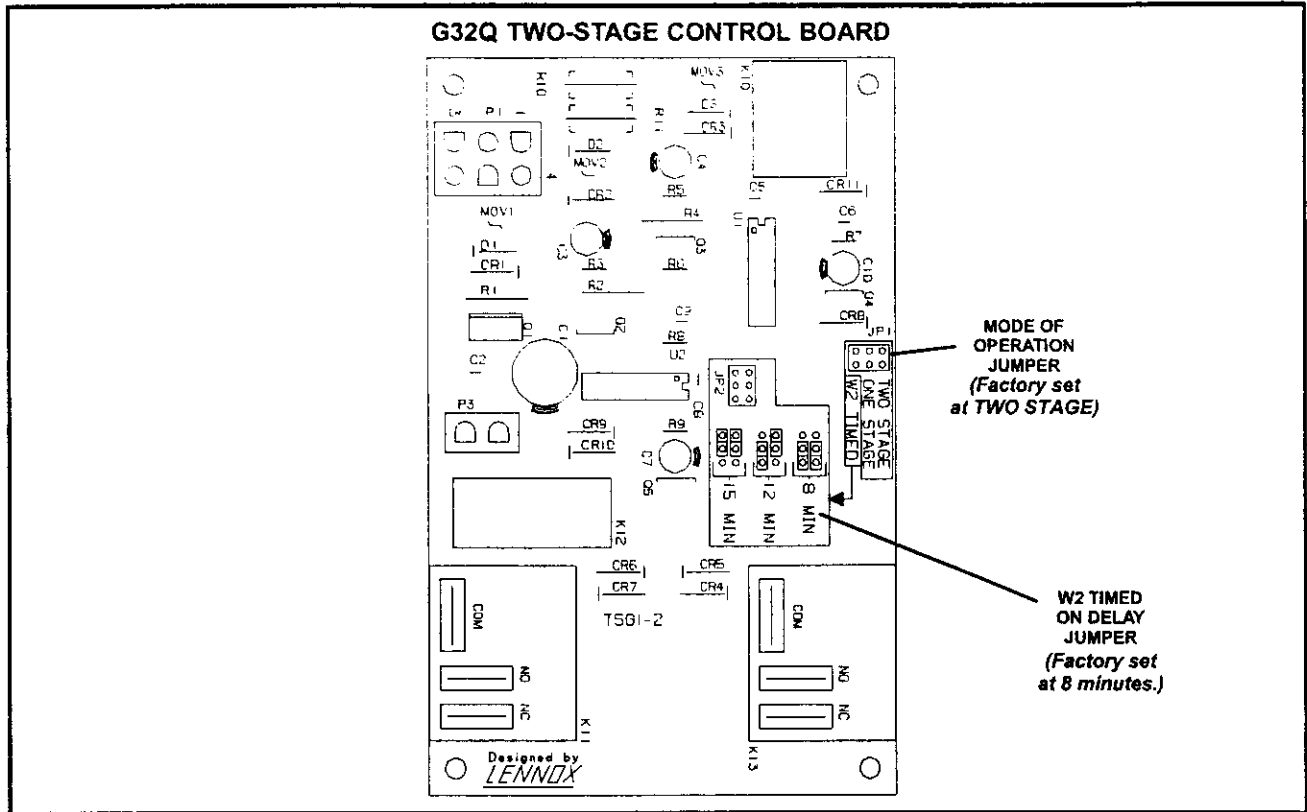

FIGURE 31

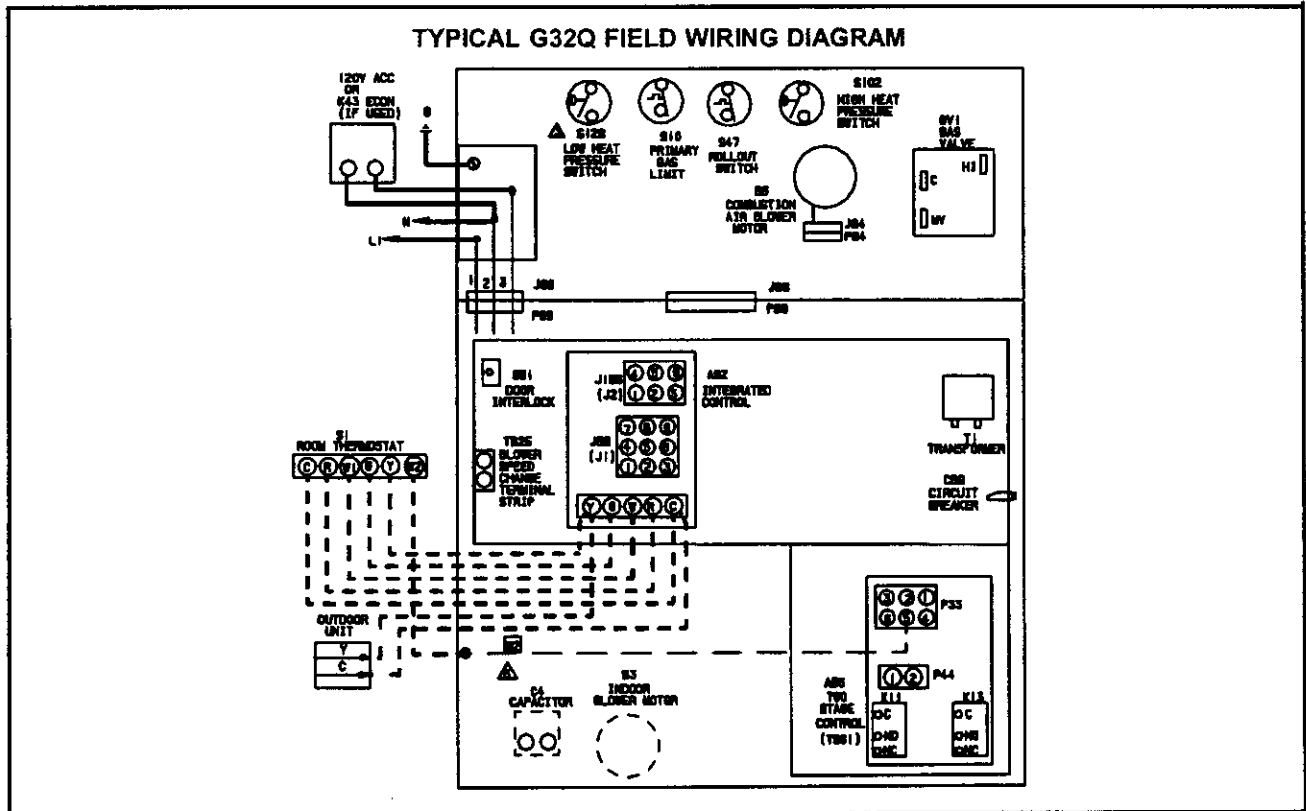
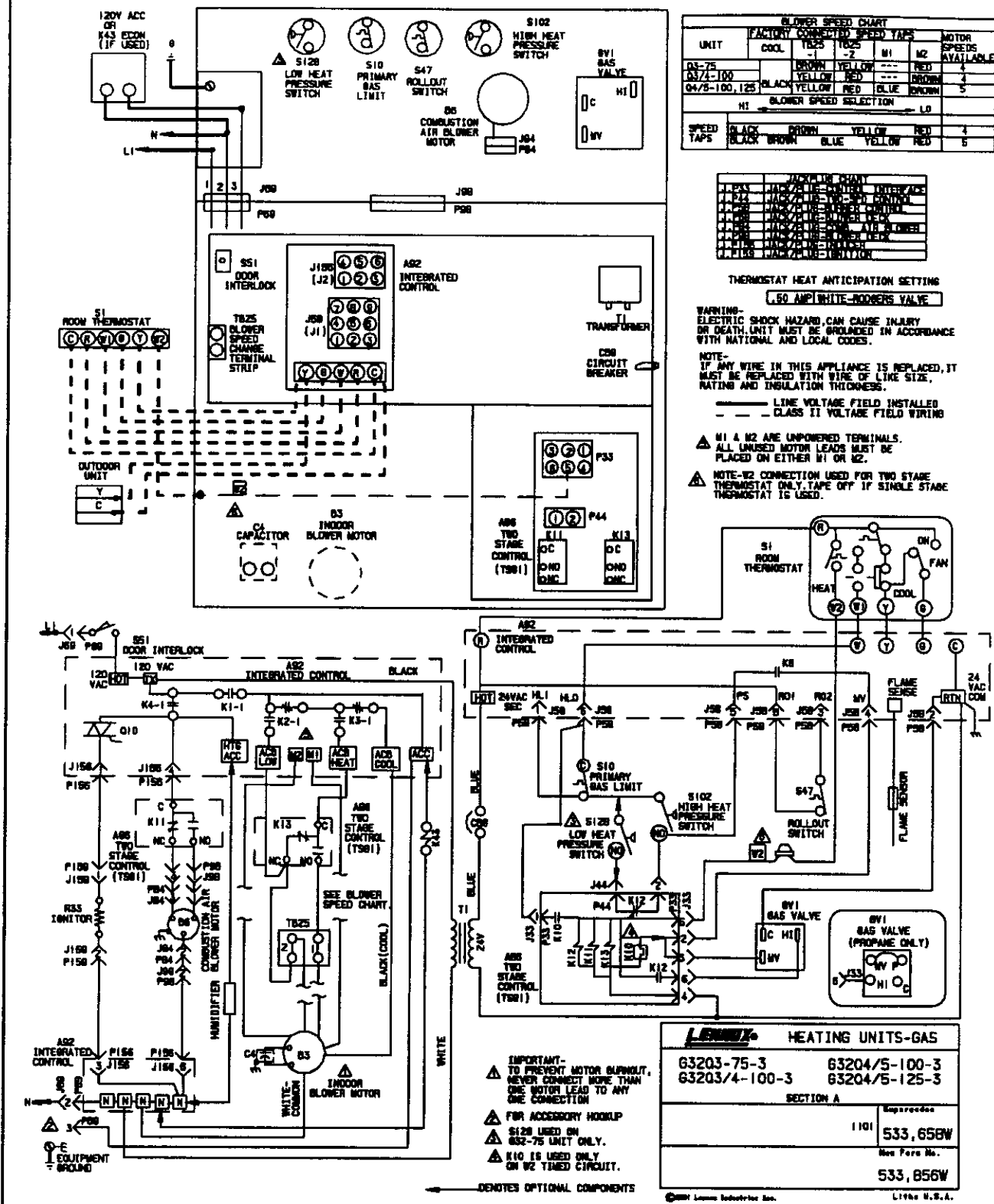

FIGURE 32

TYPICAL G32Q SCHEMATIC WIRING DIAGRAM



BLOWER SPEED CHART

UNIT	FACTORY CONNECTED SPEED TAPS					MOTOR SPEEDS AVAILABLE
	COOL	T825	T825	M1	M2	
D3-75		BROWN	YELLOW	---	RED	4
G3/4-100		YELLOW	RED	---	BROWN	4
Q4/5-100, 125	BLACK	YELLOW	RED	BLUE	BROWN	5

M1 ← BLOWER SPEED SELECTION → M2

SPEED TAPS	BLACK	BROWN	YELLOW	RED	4
	BLACK	BROWN	BLUE	YELLOW	RED

WIRE COLOR	WIRE SIZE	WIRE TYPE	WIRE LENGTH
BLACK	14	THIN	100'
BROWN	14	THIN	100'
YELLOW	14	THIN	100'
RED	14	THIN	100'
BLUE	14	THIN	100'
GREEN	14	THIN	100'
WHITE	14	THIN	100'

TERMOSTAT HEAT ANTICIPATION SETTING
.50 AMP WHITE-RODGERS VALVE

WARNING- ELECTRIC SHOCK HAZARD, CAN CAUSE INJURY OR DEATH. UNIT MUST BE GROUNDED IN ACCORDANCE WITH NATIONAL AND LOCAL CODES.

NOTE- IF ANY WIRE IN THIS APPLIANCE IS REPLACED, IT MUST BE REPLACED WITH WIRE OF LIKE SIZE, RATING AND INSULATION THICKNESS.

— LINE VOLTAGE FIELD INSTALLED
 - - - CLASS II VOLTAGE FIELD WIRING

▲ M1 & M2 ARE UNPOWERED TERMINALS. ALL UNUSED MOTOR LEADS MUST BE PLACED ON EITHER M1 OR M2.

▲ NOTE-W2 CONNECTION USED FOR TWO STAGE THERMOSTAT ONLY. TAPE OFF IF SINGLE STAGE THERMOSTAT IS USED.

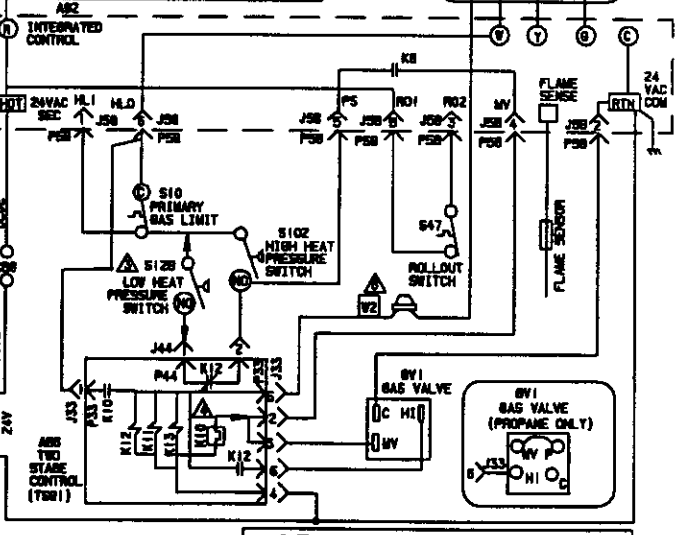
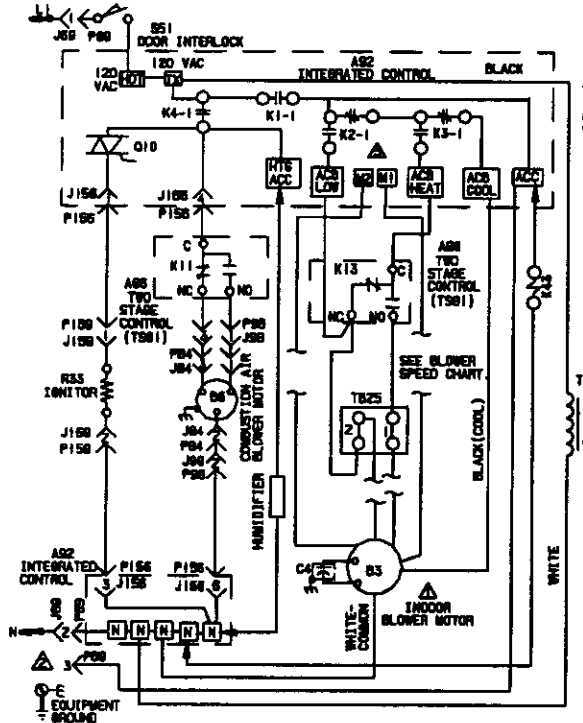
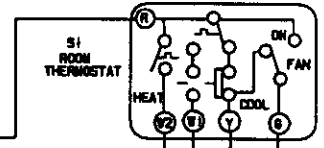

- ▲ IMPORTANT- TO PREVENT MOTOR OVERHEAT, NEVER CONNECT MORE THAN ONE MOTOR LEAD TO ANY ONE CONNECTION
- ▲ F8R ACCESSORY HOOKUP
- ▲ S128 USED ON G32-75 UNIT ONLY.
- ▲ K10 IS USED ONLY ON W2 TIMED CIRCUIT.

← DENOTES OPTIONAL COMPONENTS

LENEX HEATING UNITS-GAS

G3203-75-3	G3204/5-100-3
G3203/4-100-3	G3204/5-125-3

SECTION A

1101	Engrossed
	533, 658W
	See Form No.
	533, 656W

©1987 Lennox Industries Inc. Litho U.S.A.

FIGURE 33

Unit Start-Up

FOR YOUR SAFETY READ BEFORE OPERATING

⚠ WARNING

Do not use this furnace if any part has been under water. Immediately call a qualified service technician to inspect the furnace and to replace any part of the control system and any gas control which has been under water.

⚠ WARNING

If overheating occurs or if gas supply fails to shut off, shut off the manual gas valve to the appliance before shutting off electrical supply.

⚠ CAUTION

Before attempting to perform any service or maintenance, turn the electrical power to unit OFF at disconnect switch.

BEFORE OPERATING smell all around the appliance area for gas. Be sure to smell next to the floor because some gas is heavier than air and will settle on the floor.

This unit is equipped with a gas control knob. Use only your hand to turn the gas control knob. Never use tools. If knob will not turn by hand, do not try to repair it. Call a qualified service technician. Force or attempted repair may result in a fire or explosion.

G3Q2 units are equipped with a SureLight™ ignition system. Do *not* attempt to manually light burners on this furnace. Each time the thermostat calls for heat, the burners will automatically light. The ignitor does not get hot when there is no call for heat on units with SureLight™ ignition system.

Gas Valve Operation

⚠ WARNING

If you do not follow these instructions exactly, a fire or explosion may result causing property damage, personal injury or death.

- 1 - **STOP!** Read the safety information at the beginning of this section.
- 2 - Set thermostat to lowest setting.
- 3 - Turn off all electrical power to furnace.
- 4 - This furnace is equipped with an ignition device which automatically lights the burner. Do **not** try to light the burner by hand.

- 5 - Remove unit access panel.
- 6 - Turn gas valve knob to **OFF** position. See figure 34.
- 7 - Wait five (5) minutes to clear out any gas. If you then smell gas, **STOP!** Immediately call your gas supplier from a neighbor's phone. Follow the gas supplier's instructions. If you do not smell gas go to next step.

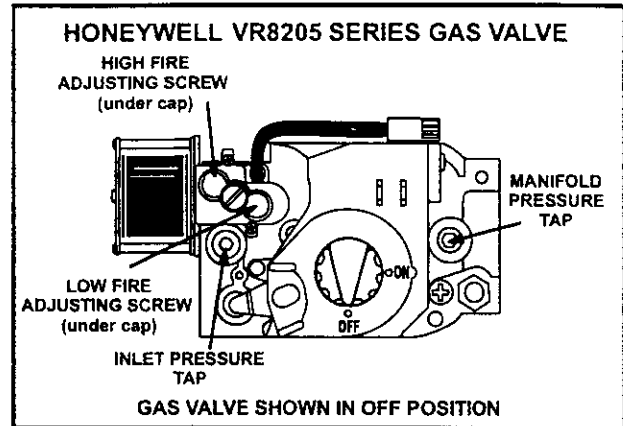

FIGURE 34

- 8 - Turn gas valve knob to **ON** position.
- 9 - Replace access panel.
- 10 - Turn on all electrical power to unit.
- 11 - Set thermostat to desired setting.
- 12 - If the appliance will not operate, follow the instructions given in "Turning Off Gas To Unit" section and call your service technician or gas supplier.

Turning Off Gas To Unit

- 1 - Set thermostat to lowest setting.
- 2 - Turn off all electrical power to unit if service is to be performed.
- 3 - Remove access panel.
- 4 - **Turn gas valve knob to OFF** position. Do not force.
- 5 - Replace access panel.

Heating Sequence of Operation

NOTE - The thermostat selection jumper on the two-stage control board is factory-set in the "TWO-STAGE" position.

Applications Using A Single-Stage Thermostat

A - Heating Sequence – Mode of Operation Jumper in "ONE-STAGE" Position

NOTE - To operate in this mode, the mode of operation jumper on the two-stage control board must be in the "ONE STAGE" position. See figure 31.

- 1 - On a call for heat, thermostat contacts close sending a signal to the integrated control module. Module runs self-diagnostic program and checks high limit switches for normally closed contacts and pressure switches for normally open contacts.
- 2 - Control module energizes combustion air inducer at high speed for 15-second prepurge.
- 3 - Control module checks pressure switches and high limit switch for closed contacts.

- 4 - After the prepurge is complete and the pressure switch is closed, a 20-second initial ignitor warm-up period begins.
- 5 - After warm-up period, gas valve is energized on second stage (high heat).
- 6 - Gas valve opens and gas is ignited. When flame is established, flame sensor sends signal to control module to de-energize the ignitor.
NOTE - If the flame is not detected after the first ignition attempt, the control module de-energizes the gas valve and the prepurge / ignition sequence is repeated. After five ignition trials without proof of flame, the unit will go into a Watchguard / Flame Failure mode. In Watchguard mode, control will repeat the prepurge and ignition trial sequence after 60 minutes of unsatisfied thermostat demand.
- 7 - After flame is sensed, 45-second FAN ON delay begins. Indoor blower is energized on high heating speed after delay. ACC and HTG ACC terminals are energized.
- 8 - When heat demand is satisfied, gas valve is de-energized, combustion air inducer goes to 5-second postpurge and adjustable FAN OFF delay begins.

B - Heating Sequence -- Mode of Operation Jumper in "W2 TIMED" Position

NOTE - To operate in this mode, the mode of operation jumper on the two-stage control board must be in the "W2 TIMED" position. See figure 31.

- 1 - On call for heat from a **single-stage thermostat**, operation sequence follows steps 1 through 4 as outlined above in single-stage heating sequence.
- 2 - Gas valve is energized on low heat (first stage). Ignition occurs and signal is sent from control module to two-stage control board to begin "W2 ON" delay (factory set at 8 minutes). See figure 31 for delay settings.
- 3 - "FAN ON" delay begins. When delay ends, indoor blower motor is energized on low speed.
- 4 - If the selected "W2 ON" delay ends and the demand for heat is still not satisfied, the two-stage control switches the furnace to second stage operation (high heat). In second stage operation, the following occur: combustion air inducer motor is energized at high speed; indoor blower motor is energized on high heating speed; and gas valve is energized on high heat after an 8-second delay.

- 5 - When the demand for heat is satisfied, the high- and low-heat gas valves are de-energized, the combustion air inducer goes into the 5-second post purge operation on low speed and the indoor blower motor goes into the FAN OFF delay on low speed.

Applications Using A Two-Stage Thermostat

C - Heating Sequence -- Mode of Operation Jumper in "TWO-STAGE" Position (Factory Setting)

The sequence of operation is the same as outlined above (in section B), except that low-heat and high-heat operation is controlled from the room thermostat.

Blower Operation

- 1 - When the thermostat is set to "FAN ON," the indoor blower will run on continuous fan speed when there is no cooling or heating demand.
- 2 - When the G32 is running in the low heat (first stage) mode, the indoor blower will run on continuous fan speed.
- 3 - When the G32Q is running in the high heat (second stage) mode, the indoor blower will run on the heating speed.
- 4 - When there is a cooling demand, the indoor blower will run on the cooling speed.

Gas Pressure Adjustment

Gas Flow

To check for proper gas flow to the combustion chamber, determine the Btu (kW) input from the unit rating plate. Divide this input rating by the Btu (kW) per cubic foot (cubic meter) of available gas. The result is the required number of cubic feet (cubic meter) per hour. Determine the flow of gas through the gas meter for two minutes and multiply by 30 to get the hourly flow of gas.

Gas Pressure

- 1 - Check gas line pressure with unit firing at maximum rate. A minimum of 4.5 in. w.c. (1.12 kPa) for natural gas should be maintained.
- 2 - After line pressure has been checked and adjusted, check high heat regulator pressure. See figure 34 for gas pressure adjustment screw location. High heat manifold pressure is given in table 6.

TABLE 6

Model No.	Manifold Pressure (outlet) in. w.g. (kPa)			
	0 to 4500 ft. (0 to 1372 m) above sea level	4501 to 5500 ft. (1373 to 1676 m) above sea level	5501 to 6500 ft. (1677 to 1981 m) above sea level	6501 to 7500 ft. (1982 to 2286 m) above sea level
G32-75 natural	3.5	3.5	3.5	3.5
G32-100 natural	3.5 (0.87)	3.4 (0.85)	3.3 (0.82)	3.2 (0.80)
G32-125 natural				
G32-75 L.P.	7.5	7.5	7.5	7.5
G32-100 L.P.	7.5 (1.90)	7.3 (1.81)	7.1 (1.80)	7.0 (1.74)
G32-125 L.P.	7.5 (1.90)	7.3 (1.81)	7.1 (1.80)	7.0 (1.74)

Manifold Pressure Measurement & Adjustment

NOTE - Pressure test adaptor kit (10L34) is available from Lennox to facilitate manifold pressure measurement.

- 1 - Connect test gauge to outlet tap on gas valve.
- 2 - Disconnect pressure sensing hose from gas valve and plug hose by covering opening with tape or equivalent. Leave barbed fitting on valve open to atmosphere. See figure 35 for differential pressure switch circuitry on 75 kBtuh models. Only 75 kBtuh models are equipped with a second pressure switch. Other models have single pressure switch.

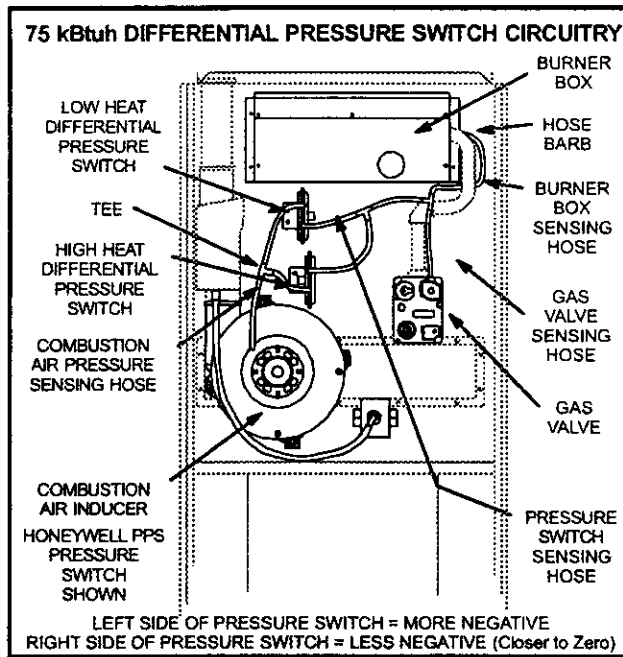

FIGURE 35

- 3 - Start unit on high heat and allow 5 minutes for unit to reach steady state.
- 4 - While waiting for the unit to stabilize, notice the flame. Flame should be stable and should not lift from burner. Natural gas should burn blue.
- 5 - After allowing unit to stabilize for 5 minutes, record manifold pressure and compare to value given in table 6.

NOTE - Shut unit off and remove manometer as soon as an accurate reading has been obtained. Take care to replace pressure tap plug.

NOTE - During this test procedure, the unit will be overfiring:

- Operate unit only long enough to obtain accurate reading to prevent overheating heat exchanger.
 - Attempts to clock gas valve during this procedure will be inaccurate. Measure gas flow rate only during normal unit operation.
- 6 - When test is complete remove obstruction from hose and return hose to gas valve barbed fitting.

High Altitude Information

Refer to table 6 for manifold pressure settings for installations at altitudes from 0 to 7500 feet (0 to 2286 m).

NOTE - In Canada, certification for installations at elevations over 4500 feet (1372 m) is the jurisdiction of local authorities.

The two pressure switches (high and low heat) are factory set and are not to be adjusted.

Other Unit Adjustments

NOTE - Disconnect power to unit before making any adjustments.

Heat Anticipation Settings

Thermostat anticipator setting (if adjustable) should be set according to amps listed on wiring diagram on unit.

Flame Rollout Switch

Factory set: No adjustment necessary.

Limit Control

Factory set: No adjustment necessary.

Pressure Switches

Factory set: No adjustment is necessary.

Fan Control

The fan-on delay of 45 seconds is not adjustable. The fan-off delay (time that the blower operates after the heating demand has been satisfied) can be adjusted by moving the jumper on the integrated control board. The unit is shipped with a factory fan-off delay of 180 seconds. The fan-off delay will affect comfort and is adjustable to satisfy individual applications. See figure 36.

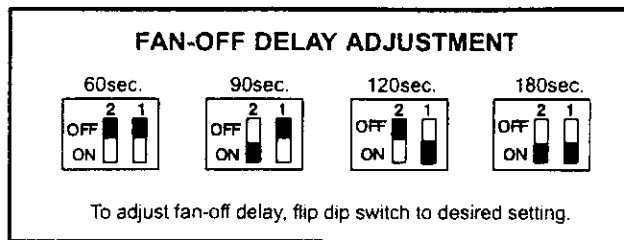

FIGURE 36

Temperature Rise

Check temperature rise and, if necessary, adjust blower speed to maintain temperature rise within range shown on unit rating plate.

Two-Stage Control

The two-stage control allows the field selection of one of three modes of operation:

- "TWO STAGE" operation controlled by a two-stage room thermostat;
- "ONE STAGE" operation controlled by a single-stage room thermostat (high heat only); and
- "W2 TIMED" operation with second stage timed ON controlled by a single-stage room thermostat. Three second-stage timed ON settings are available for field selection. They are 8, 12 and 15 minutes. (The factory setting is 8 minutes.) Refer to figure 31 for control board layout and jumper locations.

Electrical

- Check all wiring for loose connections.
- Check circuit breaker located on unit control box.
- Check for the correct voltage at the furnace (furnace operating).
- Check amp-draw on the blower motor.
Motor Nameplate _____ Actual _____.

NOTE - Do not secure electrical conduit directly to ducting or structure.

Blower Speeds

Refer to blower speed selection chart on unit wiring diagram.

NOTE - CFM readings are taken external to unit with a dry evaporator coil, filter installed and without any other accessories.

Electronic Ignition

The SureLight™ integrated control has an added feature of an internal watchdog control. The feature serves as an automatic reset device for ignition controls locked out because the burner has failed to light. After one hour of continuous thermostat demand for heat, the watchdog will break and remake thermostat demand to the furnace and automatically reset the control to relight the furnace.

Burner Flame

Start burner and allow to operate for a few minutes to establish normal burning conditions. Check burner flame by observation. Flame should be predominantly blue and strong in appearance.

Check burner flame periodically to ensure proper operation.

Service

⚠ WARNING

Disconnect power before servicing unit.

⚠ CAUTION

Label all wires prior to disconnection when servicing controls. Wiring errors can cause improper and dangerous operation. Verify proper operation after servicing.

Annual Service

At the beginning of each heating season, system should be checked as follows by a qualified service technician:

Electrical

- Check all wiring for loose connections.
- Check circuit breaker located on unit control box.
- Check for the correct voltage at the furnace (furnace operating).
- Check amp-draw on the blower motor.
Motor Nameplate _____ Actual _____
- Check to see that heat (if applicable) is operating.

Blower

Check the blower wheels for debris and clean if necessary. The blower motors are prelubricated for extended bearing life. No further lubrication is needed.

Filters

- Filters must be cleaned or replaced when dirty to assure proper furnace operation.
- Reusable foam filters used with the unit can be washed with water and mild detergent. When dry, they should be sprayed with filter handcoater prior to reinstallation. Filter handcoater is RP Products coating no. 418 and is available as Lennox part no. P-8-5069.
- If replacement is necessary, order Lennox part no. 31J81 for 14 inches x 25 inches (356 x 635 mm) filter for G32-75 units and P-8-7831 for 20 inches x 25 inches (508 x 635 mm) filter for G32-100 and -125 units.

Intake and Exhaust Lines

Check intake and exhaust lines and all connections for tightness and make sure there is no blockage. Also check condensate line for free flow during operation.

Insulation

Outdoor piping insulation should be inspected yearly for deterioration. If necessary, replace with same materials.

Winterizing and Condensate Trap Care

- Turn off power to unit.

- 2 - Have a shallow pan ready to empty condensate water. Avoid spilling water into the control box.
- 3 - Remove clamp from flue assembly and remove boot or cap. Empty water from cap. Visually inspect bottom of flue assembly. Replace boot and clamp.
- 4 - Remove boot from condensate trap and empty water. Inspect trap then replace boot.

Cleaning DuralokPlus™ Heat Exchanger

If cleaning the heat exchanger is necessary, follow the procedures below, and refer to figure 1 while you disassemble the furnace. Place papers or protective covering in front of the furnace while you remove the heat exchanger assembly.

- 1 - Turn off electrical and gas power supplies to furnace.
- 2 - Remove upper and lower furnace access panels.
- 3 - Remove four screws around air intake fitting and lift intake pipe up and away.
- 4 - Loosen hose clamp securing top of flue transition to bottom of flue collar. Remove screw securing flue collar to top cap and lift exhaust pipe and flue collar up and away.
- 5 - If electrical field make-up box is located inside the unit, it must be removed.
- 6 - Remove gas supply line connected to gas valve.
- 7 - Mark all gas valve wires and disconnect them from valve. Mark and remove wires from flame roll-out switch.
- 8 - Remove top cap of unit.
- 9 - Remove sensor wire from SureLight™ control. Disconnect 2-pin plug from the ignitor.
- 10 - Mark and disconnect pressure switch tubing from both sides of the pressure switch(es).
- 11 - Loosen two screws holding gas manifold support at vestibule panel.
- 12 - Remove four burner box screws at the vestibule panel and remove burner box and gas valve/manifold assembly with bracket.
- 13 - Drain condensate trap. Disconnect condensate line from the outside of unit. Remove condensate line from condensate trap by turning the adapter fitting counterclockwise. The fitting has standard right hand threads.
- 14 - Disconnect the drain hose from the flue transition to the elbow on the cold header (collector) box trap.
- 15 - Disconnect the 3-pin plug from the combustion air inducer at the blower deck. Remove four screws from combustion air inducer and remove flue transition and inducer assembly from cabinet. Take care not to lose the combustion air orifice.
- 16 - Mark and disconnect all remaining wires from heating compartment components .
- 17 - Disengage strain relief bushing from blower deck and pull bushing and wires into the blower section.
- 18 - Remove the limit switch and the pressure switch(es) from the vestibule panel.
- 19 - Remove two screws from the front cabinet flange at the blower deck. Remove front screws from cabinet at blower deck on left and right sides. Cabinet sides must be slightly spread to clear heat exchanger passage.
- 20 - Remove screws along vestibule sides and bottom which secure vestibule panel and heat exchanger assembly to cabinet. Remove heat exchanger.
- 21 - Back wash heat exchanger with soapy water solution or steam. **If steam is used it must be below 275°F (135°C).**
- 22 - Thoroughly rinse and drain the heat exchanger. Soap solution can be corrosive so take care that entire assembly is completely rinsed.
- 23 - Reinstall heat exchanger into cabinet making sure that the clamshells of the heat exchanger assembly are resting in the notches of the support located at the rear of the cabinet. This can be viewed by removing the indoor blower and examining through the blower opening.
- 24 - Resecure the supporting screws along the vestibule sides and bottom to the cabinet.
- 25 - Reinstall cabinet screws on sides and front flange at blower deck.
- 26 - Reinstall the limit switch and pressure switches on the vestibule panel.
- 27 - Route heating component wiring back through the hole in the blower deck and reinsert strain relief bushing. Reconnect wires.
- 28 - Reinstall the combustion air inducer. Check to ensure that the plastic orifice on the blower inlet has not fallen out. See figure 1. Reconnect the 3-pin plug to the wire harness. Reinstall the flue transition in the cabinet and reattach the drain tube. Route the drain tube below the combustion air inducer housing and to the elbow on the cold header (collector) box trap. See figure 35.
- 29 - Reinstall condensate line with adapter to condensate trap. Use fresh Teflon tape to ensure a leak-free joint. Re-connect to condensate line outside of the unit.
- 30 - Reinstall the burner box. Tighten the screws holding the support bracket. It is important that the glass fiber gasket not be damaged so it will provide a continuous seal between the burner box and the vestibule panel.
- 31 - Reconnect pressure switch tubing by connecting the tubing from the burner box to the barbed fitting on the bottom and the tubing from the combustion air inducer to the barbed fitting on the top. See figure 35.
- 32 - Reconnect the sensor and ignitor wires.
- 33 - Reinstall top cap to unit.

- 34 - Reconnect wiring to gas valve. Brown wire to "HI," yellow wire to "C" and orange wire to "M." Reconnect wires to flame roll-out switch.
NOTE - Unit is polarity-sensitive. 120V supply wiring must be installed correctly.
- 35 - Reconnect main gas line to gas valve. Use second wrench on gas valve to avoid transferring torque to the gas manifold.
- 36 - Reinstall field make-up box if removed.
- 37 - Reinstall exhaust pipe/flue collar and secure flue collar to the unit top cap using existing screw. Insert the bottom of the flue collar into the top of the flue transition and tighten hose clamp.
- 38 - Reinstall intake pipe fitting on burner box with screws.
- 39 - Replace both upper and lower access panels.
- 40 - Refer to instruction on verifying gas and electrical connections when re-establishing supply.
- 41 - Following lighting instructions from installation manual, light and run unit for 5 minutes to ensure heat exchanger is clean, dry and operating safely.

Cleaning the Burner Assembly

- 1 - Turn off electrical and gas power supplies to furnace. Remove upper and lower furnace access panels.
- 2 - Disconnect the gas supply line to gas valve. Depending on gas plumbing installation, the gas manifold may move aside enough that breaking the union may not be necessary.
- 3 - Remove five screws from edges of burner box cover.
- 4 - Loosen two screws on bottom of burner box front. The cover is key holed at these screw point so screws do not need to be removed. Pull off cover and set aside.
- 6 - Mark all gas valve wires and disconnect them from valve.
- 7 - Mark and disconnect sensor wires from the burner box at the ignition control. Disconnect 2-pin plug from the ignitor at the burner box.
- 8 - Loosen two screws at the gas manifold support bracket.
- 9 - Pull on the left side of the gas manifold and follow with tension to the right side. The manifold support bracket will be free of the mounting screws on the vestibule panel. Set the gas manifold/gas valve assembly aside. Take care not to damage foam gaskets on each end of the gas manifold.
- 10 - Using a 1/4 inch nut driver, remove the burner mounting screws from underneath the burners.
- 11 - While supporting ignitor and sensor lines at the grommet, grasp burners and simultaneously pull burners and grommet out of the burner box.
- 12 - Remove ignitor and sensor bracket assemblies from burners using a 1/4 inch nut driver to remove two screws from each bracket.
- 13 - Clean burner by running a vacuum with a soft brush attachment over face of burners. Use burner brush to clean inside of burners. Visually inspect inside of burners and crossovers for any blockage caused by foreign matter. Remove any blockage.
- 14 - Reinstall ignitor and sensor bracket assemblies on burners.
NOTE - Ignitor must be installed on the opposite side of the burner from the metal button protrusions. Screws which attached the ignitor bracket must be installed from the same side as the ignitor and through the bracket to engage in the smaller holes located in the burner. The correct burner orientation is with metal button protrusions always pointing up.
- 15 - Replace burner ignitor assembly back into burner box so that grommet groove fits back into sheet metal notch and makes a good seal. The burners sit on top of the burner box flanges. Make certain that the screws from underneath the box pass through the larger holes in the flange and engage in the smaller holes in the burner. Reinstall the two screws.
- 16 - Reinstall the gas manifold/gas valve assembly by first inserting the right hand side of the gas manifold into the burner box. Swing left side of manifold into box while engaging support bracket to vestibule panel screws. Check that foam gaskets are providing a seal around each end of the gas manifold. All gas orifices should be engaged. If at this point the burners were mounted in the wrong holes, this needs to be corrected. The saddle brackets on the gas manifold should be flush with the front surfaces on the burner box sides.
- 17 - Inspect the dual layered metal pieces at the front lip of the cover. These pieces must sandwich around the metal. Reinstall burner box cover.
- 18 - Reinstall the screws to secure the burner box cover. Make sure screws are tight to ensure a leak tight burner box. Tighten the two screws underneath the box. Again, inspect the grommet to ensure a tight seal.
- 19 - Tighten the two screws holding the manifold bracket to the vestibule panel.
- 20 - Reinstall the electrical connections to the gas valve. Brown wire to "HI" yellow wire to "C" and orange wire to "M."
- 21 - Reinstall the 2-pin ignitor plug at the burner box. Reinstall sensor line to ignition control spade connector.
- 22 - Reconnect gas line to gas valve.
- 23 - Replace lower access panel.
- 24 - Following lighting instructions and gas line connection test procedures from installation manual.
- 25 - Replace upper access panel.

Repair Parts List

The following repair parts are available through independent Lennox dealers. When ordering parts, include the complete furnace model number listed on the unit rating plate. Example: G32Q3-75-1.

CABINET PARTS

Cabinet cap
Blower panel
Upper access panel

CONTROL PANEL PARTS

Two-Stage control board
Surelight™ integrated control board
Transformer
Circuit breaker
Door interlock switch

BLOWER PARTS

Blower wheel
Motor
Motor mounting frame (Q4/5 only)
Motor capacitor
Blower housing cut-off plate
Blower housing

HEATING PARTS

Heat exchanger/coil assembly

Gas manifold
Combustion air inducer
Main burner orifices
Main burners
Two-stage gas valve
Ignitor
Primary limit control
Flame rollout switch
Filter and filter rack assembly
Flue transition
Pressure switch - high heat (-75 only)
Pressure switch - low heat
Flame sensor
Sight glass and grommet
Rubber boot trap
Foam manifold gaskets
Two-speed combustion air inducer
Condensate pipe plug and adapter
Cold end header (collector) box

Troubleshooting

DIAGNOSTIC CODES

Make sure to identify LED'S Correctly.
Refer to figure 30 for control board layout.

LED #1	LED #2	DESCRIPTION
SIMULTANEOUS SLOW FLASH	SIMULTANEOUS SLOW FLASH	Power on - Normal operation. Also signaled during cooling and continuous fan.
SIMULTANEOUS FAST FLASH	SIMULTANEOUS FAST FLASH	Normal operation - signaled when heating demand initiated at thermostat.
SLOW FLASH	ON	Primary or secondary limit switch open. Limit must close within 3 minutes or unit goes into 1 hour Watchguard.
OFF	SLOW FLASH	Pressure switch open or has opened 5 times during a single call for heat; OR: Blocked inlet/exhaust vent; OR: Pressure switch closed prior to activation of combustion air inducer.
ALTERNATING SLOW FLASH	ALTERNATING SLOW FLASH	Watchguard -- burners failed to ignite; OR limit open more than 3 minutes; OR lost flame sense 5 times in one heating cycle; OR pressure switch opened 5 times in one heating cycle.
SLOW FLASH	OFF	Flame sensed without gas valve energized.
ON	SLOW FLASH	Rollout switch open.
ON ON OFF	ON OFF ON	Circuit board failure or control wired incorrectly. Check 24 and 115 volts to board.
FAST FLASH	SLOW FLASH	Main power polarity reversed. Switch line and neutral.
SLOW FLASH	FAST FLASH	Low flame signal. Measures below .7 microAmps. Replace flame sense rod.
ALTERNATING FAST FLASH	ALTERNATING FAST FLASH	The following conditions are sensed during the ignitor warm-up period only: 1) Improper main ground; 2) Broken ignitor; OR: Open ignitor circuit; 3) Line voltage below 75 volts. (If voltage lower than 75 volts prior to ignitor warm-up, control will signal waiting on call from thermostat, and will not respond.

NOTE - Slow flash equals 1 Hz (one flash per second). Fast flash equals 3 Hz (three flashes per second). Dropout flame sense current = 0.15 to 0.17 microAmps.

HEATING SEQUENCE OF OPERATION

NORMAL HEATING MODE

ABNORMAL HEATING MODE

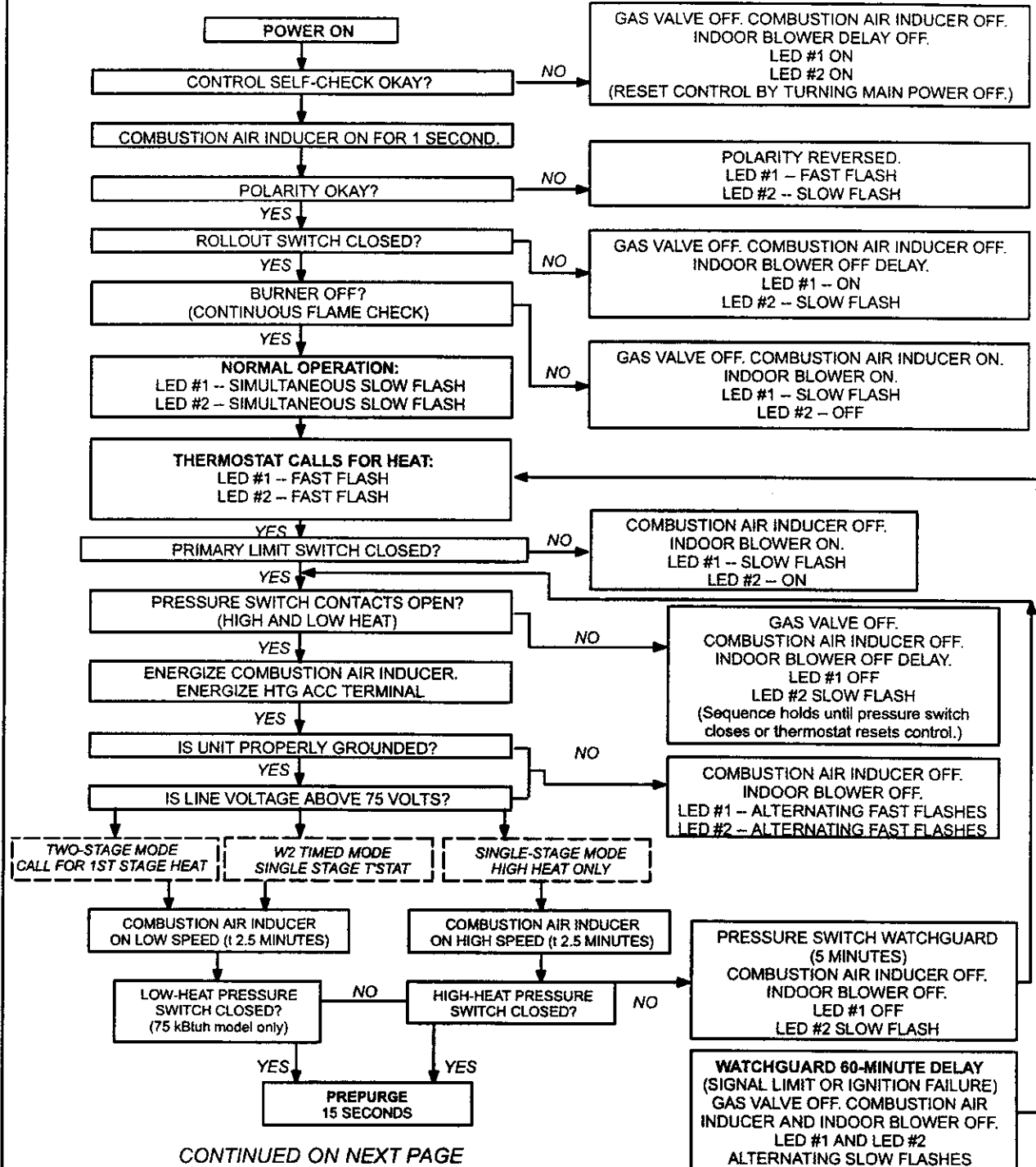

CONTINUED ON NEXT PAGE

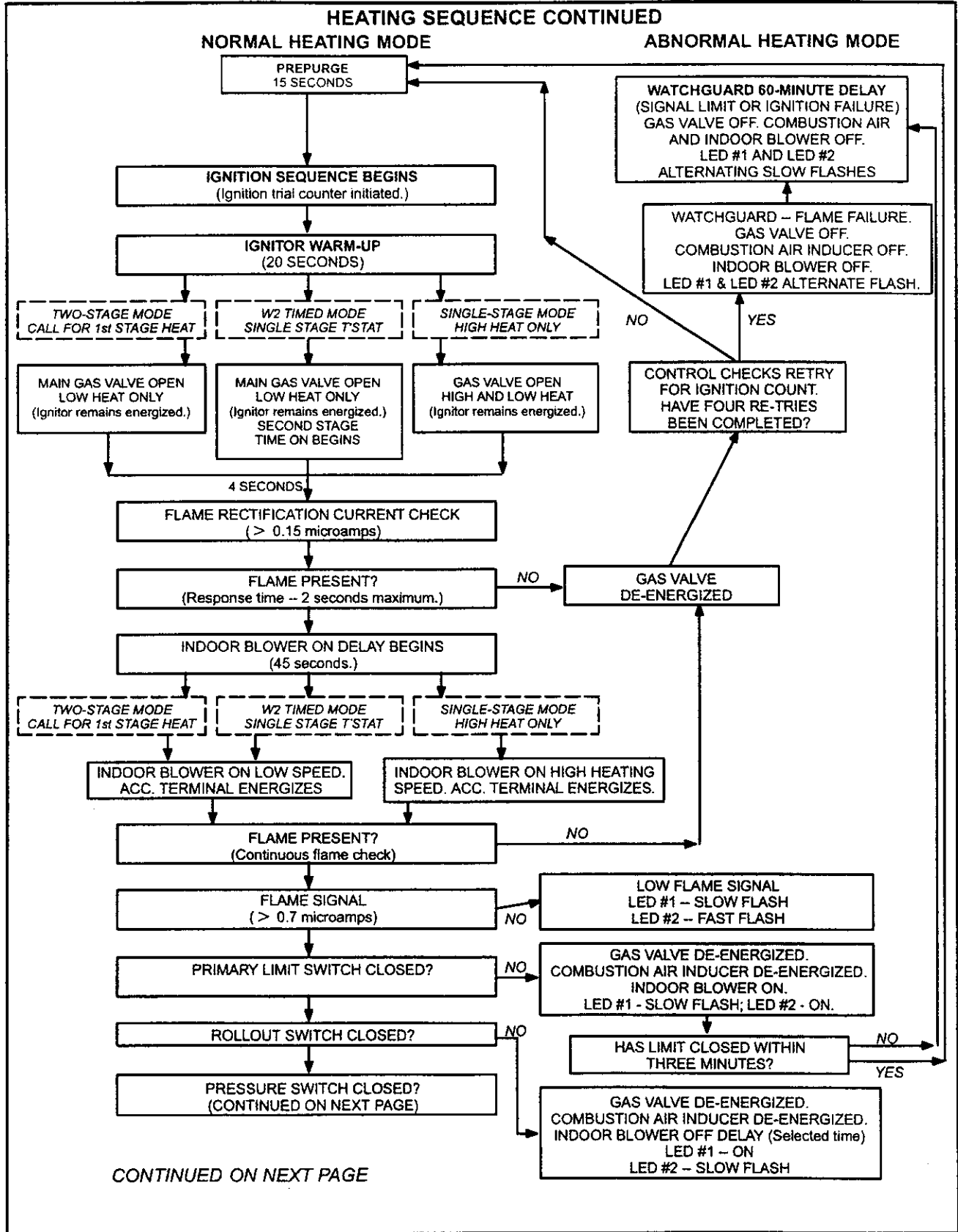

CONTINUED ON NEXT PAGE

HEATING SEQUENCE CONTINUED

NORMAL HEATING MODE

ABNORMAL HEATING MODE

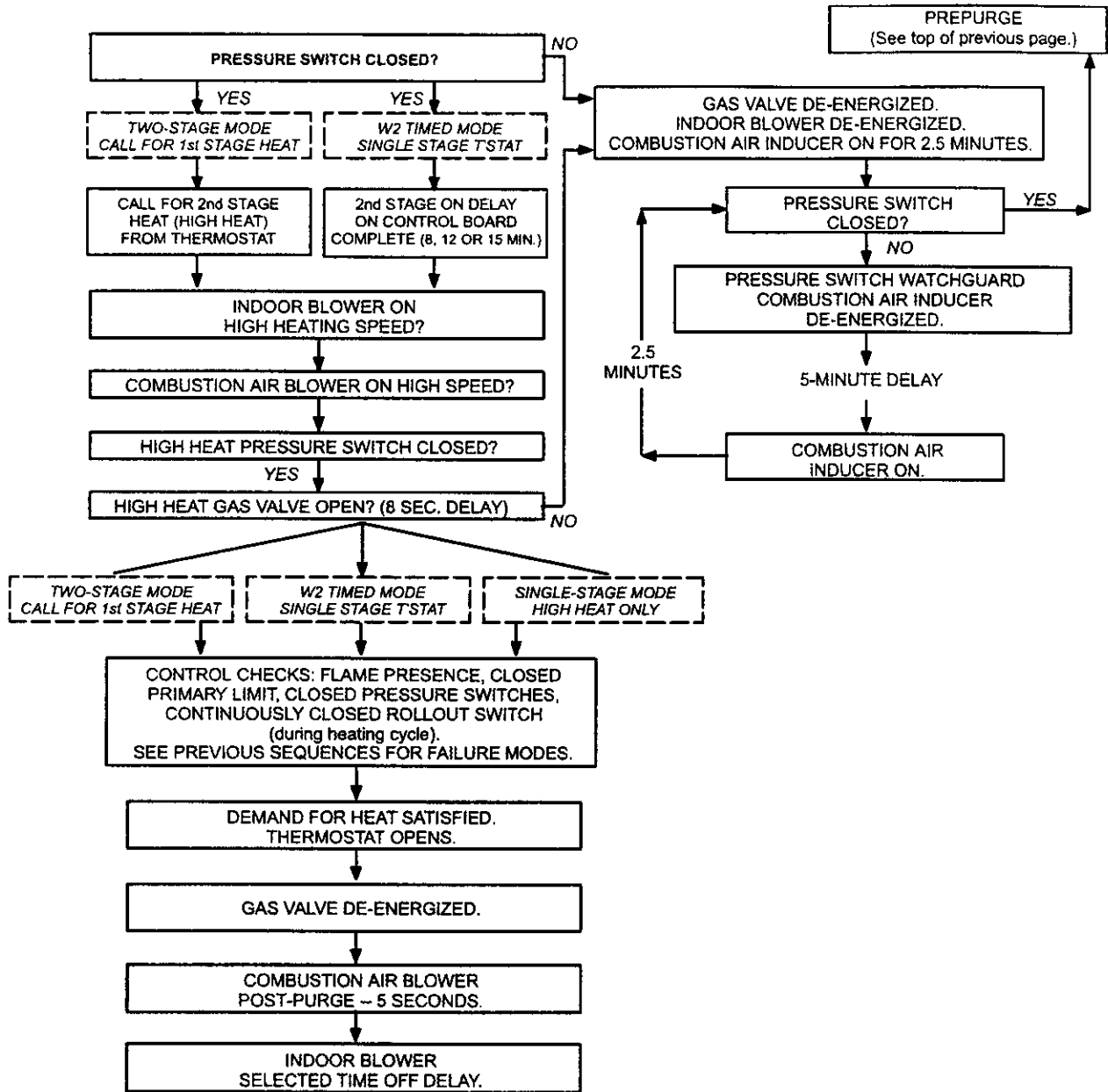

COOLING SEQUENCE OF OPERATION

NORMAL COOLING MODE

ABNORMAL COOLING MODE

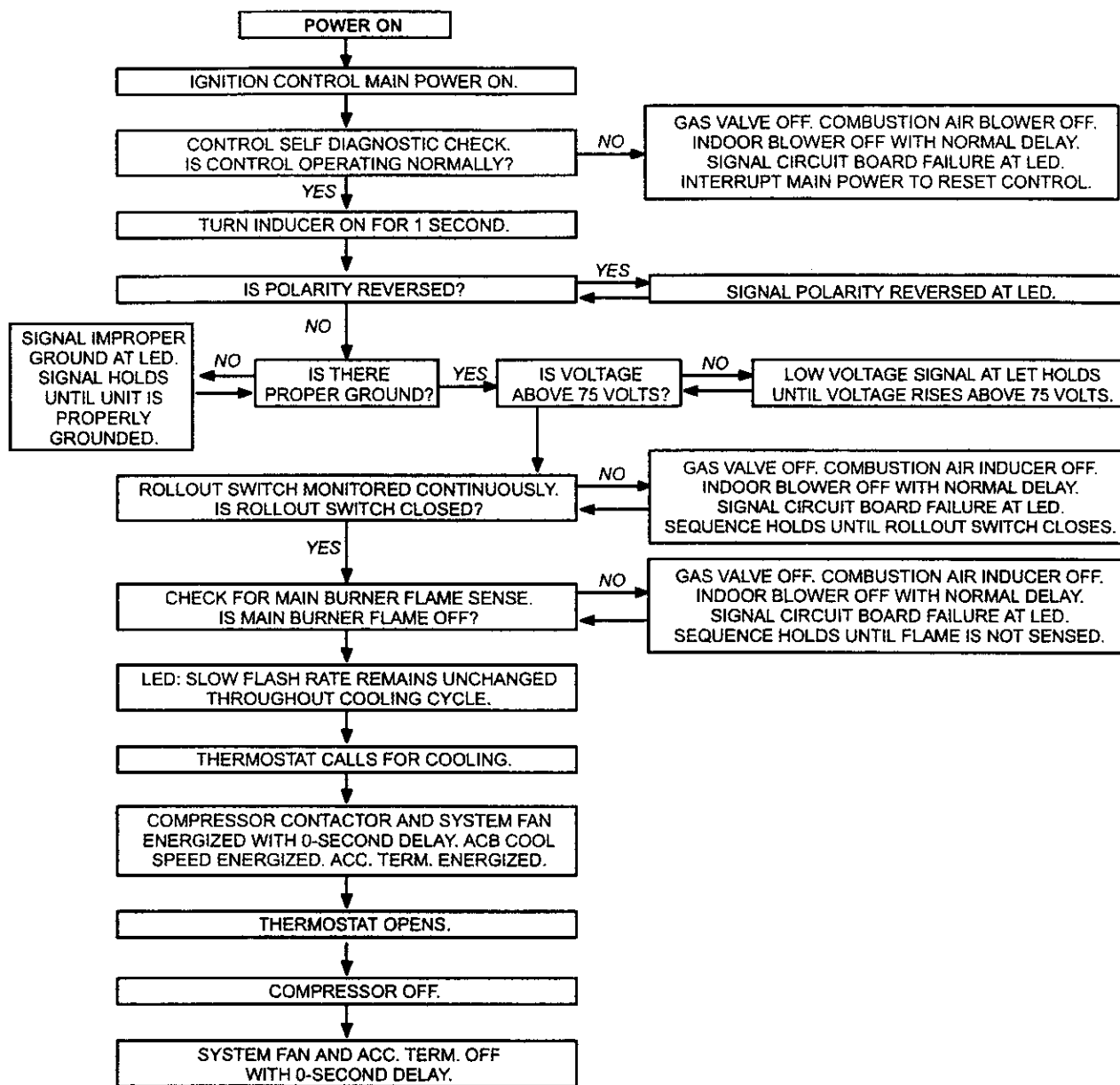

Troubleshooting

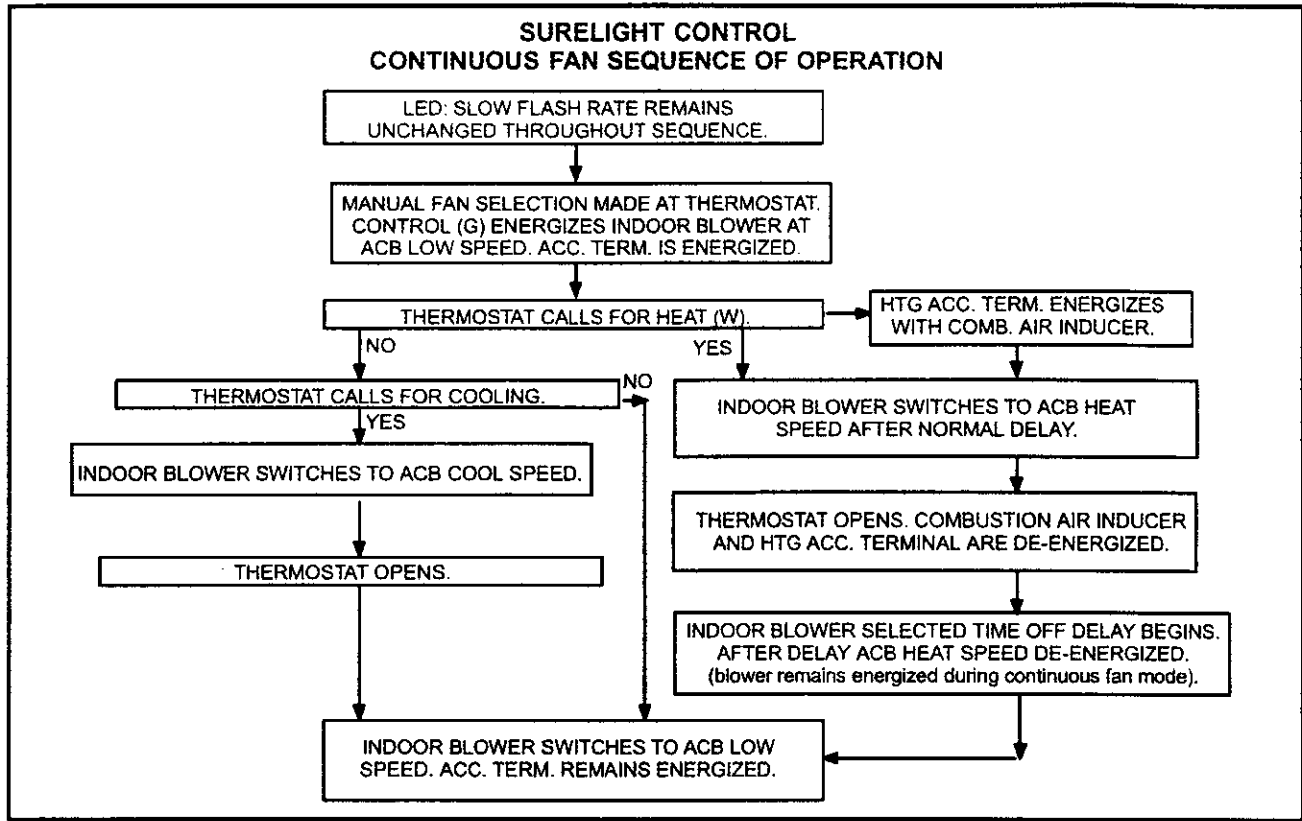

G32 Start-Up & Performance Check List

Job Name _____ Job Number _____ Date _____
 Job Location _____ City _____ State/Province _____
 Installer _____ City _____ State/Province _____
 Unit Model Number _____ Serial Number _____ Service Technician _____

HEATING SECTION

Electrical Connections Tight? Supply Voltage _____
 Blower Motor Amps _____ Blower Motor Horsepower/kW _____
 Blower Motor Lubrication OK?
 Gas Piping Connections Tight & Leaks Tested?
 Fuel Type: Natural Gas?
 Furnace Btu (kW) Input _____ Line Pressure _____
 Regulator Pressure w.c./Pa -- Nat. _____
 Air Shutters Properly Adjusted (If Installed)?
 Connections Tight? Proper Draft? _____
 Fan Control Setting (45 Seconds Fixed On) _____ Fan Control Off Setting _____
 Temperature Rise _____ Filter Clean & Secure? Vent Clear?

THERMOSTAT

Calibrated Heat Anticipator Properly Set? Level?

Free Manuals Download Website

<http://myh66.com>

<http://usermanuals.us>

<http://www.somanuals.com>

<http://www.4manuals.cc>

<http://www.manual-lib.com>

<http://www.404manual.com>

<http://www.luxmanual.com>

<http://aubethermostatmanual.com>

Golf course search by state

<http://golfingnear.com>

Email search by domain

<http://emailbydomain.com>

Auto manuals search

<http://auto.somanuals.com>

TV manuals search

<http://tv.somanuals.com>