



DURABRAND

STEREO ACTIVE SPEAKER SYSTEM

OPERATING INSTRUCTIONS

MODEL DSP-19A

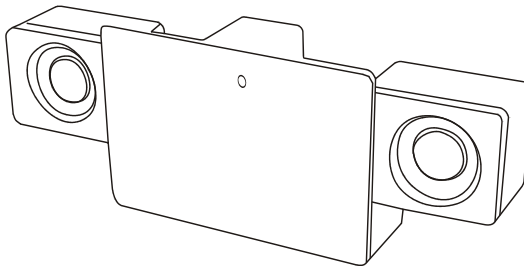

- 0.5 WATT RMS OUTPUT PER CHANNEL FOR RICH STEREO SOUND
- ROTARY VOLUME CONTROL
- POWER ON LED INDICATOR
- AUDIO IN JACK - CONNECTS TO YOUR CD PLAYER, MP3 PLAYER, COMPUTER OR ANY AUDIO DEVICE (AUDIO CABLE WITH 3.5MM PLUG INCLUDED)
- USES 4 SIZE "AAA" BATTERIES (NOT INCLUDED) OR 6V AC/DC ADAPTOR (INCLUDED)

PLEASE READ CAREFULLY BEFORE USE

IB-DSP19A-WM-E-062006



LOCATION OF CONTROLS

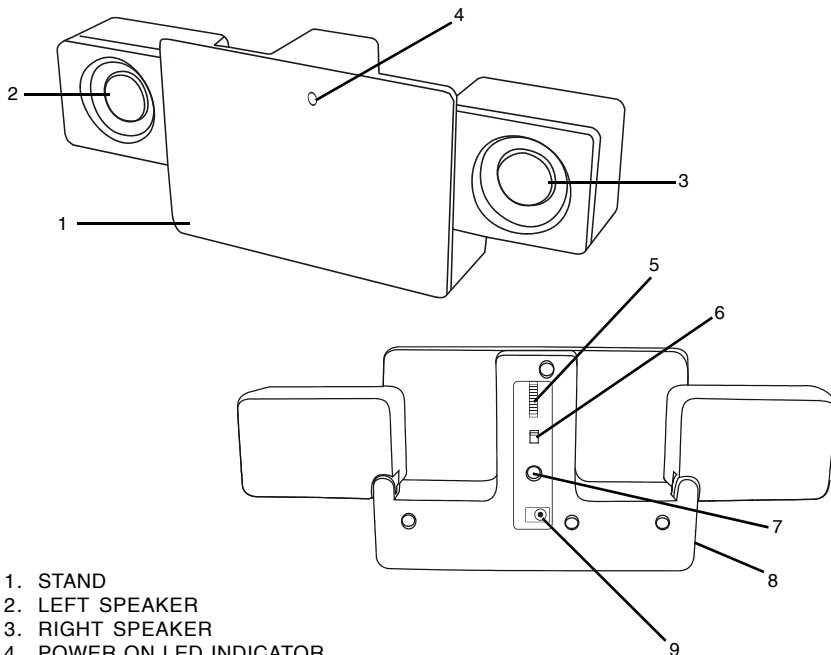

1. STAND
2. LEFT SPEAKER
3. RIGHT SPEAKER
4. POWER ON LED INDICATOR
5. VOLUME CONTROL
6. POWER ON/OFF SWITCH
7. AUDIO IN JACK (for CD player/MP3 player/Computer)
8. BATTERY DOOR
9. AC ADAPTOR JACK (AC ADAPTOR INCLUDED)



POWER SOURCE

Power your speaker system by inserting 4 size “AAA” fresh alkaline batteries or by connecting the supplied AC adaptor.

1. BATTERY INSTALLATION (batteries not included)

1. Slide the BATTERY DOOR out.
2. Insert 4 size “AAA” alkaline batteries, according to the + and – markings on the bottom of the set.
3. We recommend alkaline batteries for longer life.
4. Close the BATTERY DOOR.

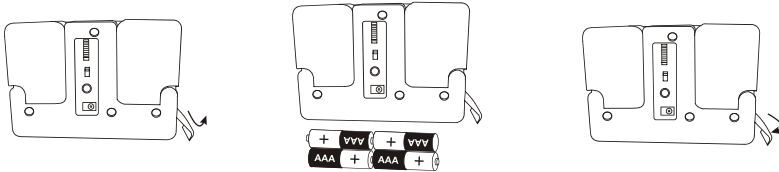

BATTERY REPLACEMENT

Exhausted batteries may leak and damage the set, or cause weak or distorted sound. Replace batteries when required.

Battery Safety

- * Do not dispose of any battery in fire.
- * Do not put the battery in a damp place.
- * Do not mix old and new batteries.
- * Do not mix alkaline, standard (Carbon-Zinc) or rechargeable batteries.
- * Please take out the batteries if you don't use the player for a long time.
- * Batteries should be installed by adults for safety.



2. AC ADAPTOR (included)

The AC adaptor suitable for this speaker system is DC 6V 500mA, with PLUS center polarity \ominus - \oplus . If you want to buy an adaptor, please choose only this type. Insert the ADAPTOR plug to the AC adaptor jack of the speaker system and connect the adaptor to a wall outlet.

SPEAKER SYSTEM OPERATION

1. Insert the included audio cable with 3.5mm plugs on each end into the LINE OUT jack or PHONES jack of your CD player or MP3 player or computer, and the other end into the AUDIO IN jack of the speaker system.

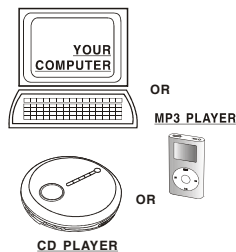
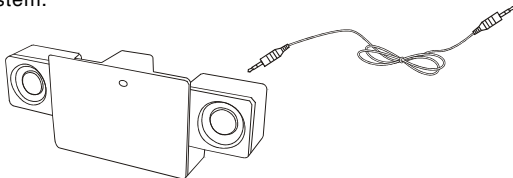

2. Slide the POWER switch of speaker system to the ON position (the LED indicator turns on).
3. Turn on your CD player or MP3 player or computer, adjust the VOLUME control of the CD player/MP3 player/computer and the speaker system to the desired levels.
4. Slide the POWER switch of speaker system to OFF position after use.

NOTE

- Do not play this system at maximum volume or too close to your ears for hearing safety.
- This stereo active speaker system is a low power system, it's suitable for your CD player/MP3 player/computer. We advise not to connect it to your home theater system or high power devices!
- Remember to slide the POWER switch to OFF position after use.





TROUBLE SHOOTING

Symptom	Remedy
No power.	<ol style="list-style-type: none">1. Is the power switched to the OFF position? Slide it to ON.2. Were the batteries inserted correctly? Please make sure 4 size "AAA" alkaline batteries are inserted into battery compartment according to the + and - markings on the bottom of the set.3. Is the adaptor cord firmly plugged into the adaptor jack? Insert the AC adaptor plug securely into the speaker.
The POWER LED indicator blinks or gets dim.	The batteries are weak, please replace the batteries with new ones or use the supplied AC adaptor.
No sound or only a very low-level sound is heard.	<ol style="list-style-type: none">1. Check that the speaker AUDIO IN cable is connected securely and correctly. Make sure the cable is inserted well.2. Make sure your speaker has power and POWER switch is in the ON position.3. Make sure the input source CD player/MP3 player/computer works well.4. Adjust the speaker system and CD player/MP3 player/computer volume control.5. The batteries are weak, please replace the batteries with new ones or use the supplied AC adaptor.
Distorted sound.	<ol style="list-style-type: none">1. Reduce input source volume or the speaker volume.2. The batteries are weak, please replace the batteries with new ones or use the supplied AC adaptor.



WARNING:

To prevent fire or shock hazard, do not expose this appliance to rain or moisture.

Do not block or obstruct the ventilation holes at the rear of the set.

SAFETY INFORMATION

1. Batteries should only be installed by adult for safety.
2. Do not load batteries with polarities (-/+) reversed.
3. Do not force batteries into the battery compartment.
4. Do not short-circuit the battery with metallic objects such as key holders or jewellery. This may damage the battery.
5. When not in use for an extended period of time, or while internal batteries will not be used, please remove them to prevent possible battery acid leakage or corrosion.
6. Clean only with a dry or very slightly damp cloth.
7. Do not use this set near water, do not expose this appliance to rain or moisture.
8. To minimize risk of possible overheating, do not block the ventilation holes at the rear cabinet.



FCC NOTES:

NOTICE FOR USA: This equipment has been tested and found to comply with the limits for a Class B digital device, pursuant to Part 15 of the FCC rules. These limits are designed to provide reasonable protection against harmful interference in a residential installation. This equipment generates, uses and can radiate radio frequency energy and, if not installed and used in accordance with the instructions, may cause harmful interference to radio communications. However, there is no guarantee that interference will not occur in a particular installation. If this equipment does cause harmful interference to radio or television reception, which can be determined by turning the equipment off and on, the user is encouraged to try to correct the interference by one or more of the following measures.

- Reorient or relocate the receiving antenna.
- Increase the separation between the equipment and receiver.
- Connect this equipment into an outlet on a circuit different from that to which the receiver is connected.
- Consult the dealer or an experienced radio/TV technician for help.

CAUTION: To comply with the limits for the Class B digital services, pursuant to Part 15 of the FCC Rules, this device must be installed with computer equipment certified to comply with the Class B limits.

Modifications

Any changes or modifications not expressly approved by the grantee of this device could void the user's authority to operate the device.

This device complies with part 15 of the FCC Rules. Operation is subject to the following two conditions: (1) This device may not cause harmful interference, and (2) this device must accept any interference received, including interference that may cause undesired operation.

SPECIFICATIONS

Power Supply

DC	: 6V, using 4 size "AAA" alkaline batteries (not included)
AC adaptor	: Input 100-240V, 50/60Hz, output 6V 500mA DC (included)
Power Output	: 0.5W/channel
Dimensions	: 4 " x 1 1/16 " x 2 3/4 " / 10 cm x 2.7 cm x 7 cm (L x W x H)
Weight	: 4.2 oz / 120 g (without batteries)





LIMITED WARRANTY

We warrant this product to be free from defects in material and workmanship under normal use for a period of 90 days after purchase and we will repair it free of charge or replace it at no charge, should it become defective under this warranty, providing you submit proof of purchase (sales slip) with the set.

During the initial 90 day period after original purchase, we will service or exchange, at no charge, the set that is returned to LENOXX ELECTRONICS CORP. After the initial 90 day period expires, and for a period of 12 months from original purchase, we will repair the unit covering any part(s) that need to be replaced at no charge, but will charge for the cost of labor, return postage paid by Lennox.

This warranty does not apply to any products which have been subject to misuse, neglect or accident. This warranty does not cover broken cord or cabinet. UNDER NO CIRCUMSTANCES WILL LENOXX ELECTRONICS CORP. BE LIABLE FOR ANY INCIDENTAL OR CONSEQUENTIAL DAMAGES. Some states do not allow the exclusion or limitation of incidental or consequential damages, so the above limitations or exclusions may not apply to you.

This warranty gives you specific legal rights, and you may also have other rights which vary from state to state. The following charges apply to repairs beyond the warranty period: \$5.00. Be sure to pack carefully and return postage paid insured together with your money order (personal checks will not be accepted) and sales receipt to:

LENOXX ELECTRONICS CORP., 35 BRUNSWICK AVENUE, EDISON, N.J. 08817, USA

We reserve the right to make design and specification changes for product improvement.

The descriptions and characteristics given in this document are given as a general indication and not as a guarantee. In order to provide the highest quality product possible, we reserve the right to make any improvement or modification without prior notice. The English version serves as the final reference on all product and operation details should any discrepancies arise in other languages.

For customer service

Dial: 1-800-315-5885 (MONDAY - THURSDAY 8:00 AM - 5:00 PM, FRIDAY 8:00 AM - 1:30 PM EST)

or Visit Our Website: <http://www.lenox.com>

or Email: evergo@att.net

© 2006 LENOXX ELECTRONICS CORP.
35 BRUNSWICK AVENUE
EDISON, N.J. 08817, USA
MADE & PRINTED IN CHINA

Free Manuals Download Website

<http://myh66.com>

<http://usermanuals.us>

<http://www.somanuals.com>

<http://www.4manuals.cc>

<http://www.manual-lib.com>

<http://www.404manual.com>

<http://www.luxmanual.com>

<http://aubethermostatmanual.com>

Golf course search by state

<http://golfingnear.com>

Email search by domain

<http://emailbydomain.com>

Auto manuals search

<http://auto.somanuals.com>

TV manuals search

<http://tv.somanuals.com>