



website:<http://biz.LGservice.com>
e-mail:<http://www.LGService.com/techsup.html>

COLOR TV SERVICE MANUAL

CHASSIS : MC-022A

**MODEL:RT-29FB50RB/RE/RP/RX
RT-29FB50VB/VE**

CAUTION

BEFORE SERVICING THE CHASSIS,
READ THE SAFETY PRECAUTIONS IN THIS MANUAL.



P/NO : 3828VD0118Z

Feb.,2003
Printed in Korea

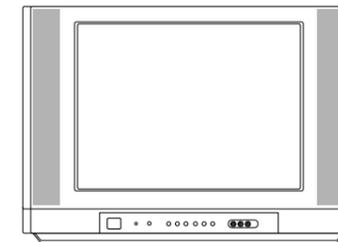

CONTENTS

Contents	2
Safety Precautions	3
Specifications	4
Control Descriptions	5
Disassembly Instructions	8
Adjustment Instructions	9
Block Diagram	16
Trouble Shooting	18
Exploded View	22
Exploded View Parts List	23
Replacement Parts List	24
SVC. Sheet	

SAFETY PRECAUTIONS

IMPORTANT SAFETY NOTICE

Many electrical and mechanical parts in this chassis have special safety-related characteristics. These parts are identified by Δ in the Schematic Diagram and Replacement Parts List.

It is essential that these special safety parts should be replaced with the same components as recommended in this manual to prevent X-RADIATION, Shock, Fire, or other Hazards.

Do not modify the original design without permission of manufacturer.

General Guidance

An **Isolation Transformer should always be used** during the servicing of a receiver whose chassis is not isolated from the AC power line. Use a transformer of adequate power rating as this protects the technician from accidents resulting in personal injury from electrical shocks.

It will also protect the receiver and its components from being damaged by accidental shorts of the circuitry that may be inadvertently introduced during the service operation.

If any fuse (or Fusible Resistor) in this TV receiver is blown, replace it with the specified.

When replacing a high wattage resistor (Oxide Metal Film Resistor, over 1W), keep the resistor 10mm away from PCB.

Keep wires away from high voltage or high temperature parts.

Due to high vacuum and large surface area of picture tube, extreme care should be used in **handling the Picture Tube**. Do not lift the Picture tube by its Neck.

X-RAY Radiation

Warning:

The source of X-RAY RADIATION in this TV receiver is the High Voltage Section and the Picture Tube. For continued X-RAY RADIATION protection, the replacement tube must be the same type tube as specified in the Replacement Parts List.

To determine the presence of high voltage, use an accurate high impedance HV meter.

Adjust brightness, color, contrast controls to minimum.

Measure the high voltage.

The meter reading should indicate

23.5 ; 15KV: 14-19 inch, 26 ; 15KV: 19-21 inch,

29.0 ; 15KV: 25-29 inch, 30.0 ; 15KV: 32 inch

If the meter indication is out of tolerance, immediate service and correction is required to prevent the possibility of premature component failure.

Before returning the receiver to the customer,

always perform an **AC leakage current check** on the exposed metallic parts of the cabinet, such as antennas, terminals, etc., to be sure the set is safe to operate without damage of electrical shock.

Leakage Current Cold Check(Antenna Cold Check)

With the instrument AC plug removed from AC source, connect an electrical jumper across the two AC plug prongs. Place the AC switch in the on position, connect one lead of ohm-meter to the AC plug prongs tied together and touch other ohm-meter lead in turn to each exposed metallic parts such as antenna terminals, phone jacks, etc.

If the exposed metallic part has a return path to the chassis, the measured resistance should be between $1M\Omega$ and $5.2M\Omega$.

When the exposed metal has no return path to the chassis the reading must be infinite.

An other abnormality exists that must be corrected before the receiver is returned to the customer.

Leakage Current Hot Check (See below Figure)

Plug the AC cord directly into the AC outlet.

Do not use a line Isolation Transformer during this check.

Connect 1.5K/10watt resistor in parallel with a 0.15uF capacitor between a known good earth ground (Water Pipe, Conduit, etc.) and the exposed metallic parts.

Measure the AC voltage across the resistor using AC voltmeter with 1000 ohms/volt or more sensitivity.

Reverse plug the AC cord into the AC outlet and repeat AC voltage measurements for each exposed metallic part. Any voltage measured must not exceed 0.75 volt RMS which is corresponds to 0.5mA.

In case any measurement is out of the limits specified, there is possibility of shock hazard and the set must be checked and repaired before it is returned to the customer.

Leakage Current Hot Check circuit

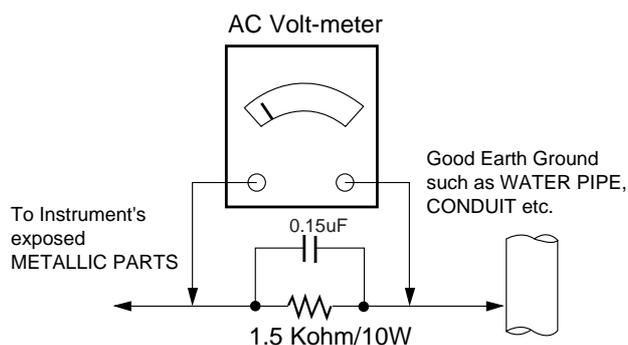

SPECIFICATIONS

Note : Specification and others are subject to change without notice for improvement.

- **Video input system:**

PAL-B/G, D/K, I/I
 SECAM-B/G, D/K/L/L'
 NTSC M
 NTSC 4.43(AV)
 NTSC- M/PAL M-N

SOUND IF : 33.4MHz (B/G)
 32.9MHz (I/I)
 32.4MHz (D/K,L)
 34.4MHz (M)
 40.4MHz (L')

- **Intermediate Frequency (Unit : MHz)**

VISION IF : 38.9MHz,33.9MHz(SECAM-L')
 COLOR IF : 34.47MHz(4.43)
 35.32MHz(3.58) : NTSC-M
 (VIF-4.25000MHz): SECAM
 VIF-4.40625MHz

- **Power requirement :** 110~240V, 50/60Hz(NON-EU)
 230V, 50Hz(EU)

- **Power consumption :** 25":125W
 29":135W

- **Tuning range**

Band	For TV				For CATV
	B/G	D/K	I/I	NTSC	
VHF-Low	Ch2-4	Ch1-5		Ch2-13	S1'-S3', S1
VHF-High	Ch5-12	Ch6-12	Ch4-13		S2-S10, S11-S20
Hyper					S21-S41
UHF	Ch21-69			Ch14-69	

- **Tuning system :**

FVS
 100 Programme memory
 200 Programme memory(W/O TXT Model)

- **Antenna input impedance :** VHF/UHF 75 ohm, unbalanced

- **Voice coil impedance :** 8 ohm

- **External In/Output**

Audio-In:0.5Vrms ± 3db,over 10Kohm
 Audio-Out:0.5Vrms ± 3db,below 1Kohm
 Video-In/Out:1Vp-p ± 3db,75ohm
 R,G,B In:0.7Vp-p ± 3db

- **Feature & Funtion**

Teletext(TOP/FLOF/LIST)
 AV Input : Side or Front(1),Rear(2)
 Component Input : Rear(Opt.)
 PERI TV Connector(AV Input,SCART Opt.)
 RGB INput
 2 Carrier Stereo : BG/DK
 NICAM Stereo : BG/I/L
 2 Carrier Dual : BG/DK
 NICAM Dual : BG/I/L
 SSC(Split Screen) Mode
 Multi Picture Display Mode(1:4:9 PIP)
 DBS

DESCRIPTION OF CONTROLS

All the functions can be controlled with the remote control handset. Some functions can also be adjusted with the buttons on the front panel of the set.

Remote control handset

Before you use the remote control handset, please install the batteries. See the next page.

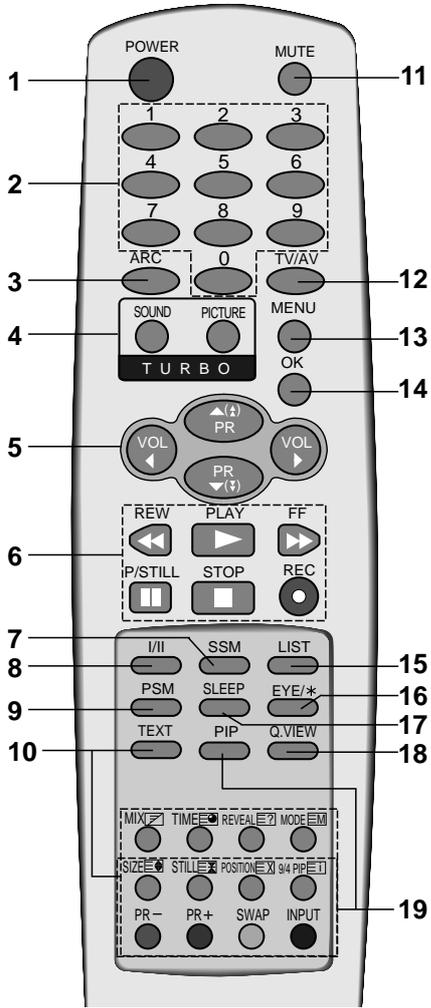

(With TELETEXT / PIP)

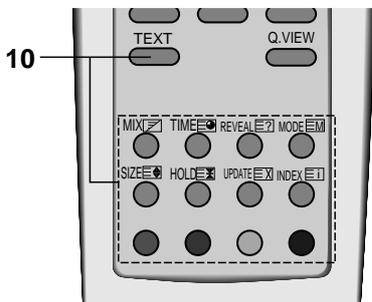

(With TELETEXT / Without PIP)

1. **POWER**
switches the set on from standby or off to standby.
2. **NUMBER BUTTONS**
switches the set on from standby or directly select a number.
3. **ARC (Aspect Ratio Control)**
changes the picture format.
4. **TURBO PICTURE / SOUND BUTTON**
selects Turbo picture / sound.
5. **▲ (▲) / ▼ (▼) (Programme Up/Down)**
selects a programme or a menu item.
◀ / ▶ (Volume Up/Down)
adjusts the volume.
adjusts menu settings.
6. **VCR BUTTONS (option)**
control a LG video cassette recorder.
7. **SSM (Sound Status Memory)**
recalls your preferred sound setting.
8. **I/II (option)**
selects the language during dual language broadcast (option).
selects the sound output.
9. **PSM (Picture Status Memory)**
recalls your preferred picture setting.
10. **TELETEXT BUTTONS (option)**
These buttons are used for teletext.
For further details, see the 'Teletext' section.
11. **MUTE**
switches the sound on or off.
12. **TV/AV**
selects TV or AV mode.
switches the set on from standby.
13. **MENU**
selects a menu.

- 14. OK**
accepts your selection or displays the current mode.
- 15. LIST**
displays the programme table.
- 16. EYE/* (option)**
switches the eye function on or off.
- 17. SLEEP**
sets the sleep timer.
- 18. Q.VIEW**
returns to the previously viewed programme.
selects a favorite programme.
- 19. PIP BUTTONS (option)**
PIP
switches the sub picture on or off.
PR +/-
selects a programme for the sub picture.
SWAP
alternates between main and sub picture.
INPUT
selects the input mode for the sub picture.
SIZE
adjusts the sub picture size.
STILL
freezes motion of the sub picture.
POSITION
relocates the sub picture in clockwise direction.
9/4 PIP
switches on or off the 9 or 4 sub pictures.

COLOURED BUTTONS

These buttons are used for teletext (only TELETEXT models) or programme edit.

Battery installation

The remote control handset is powered by two AA type batteries. To load the batteries, turn the remote control handset over and open the battery compartment. Install two batteries as indicated by the polarity symbols (+ and -) marked inside the compartment.

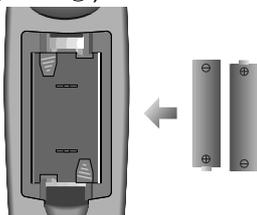

Note : To avoid damage from possible battery leakage, remove the batteries if you do not plan to use the remote control handset for an extended period of time.

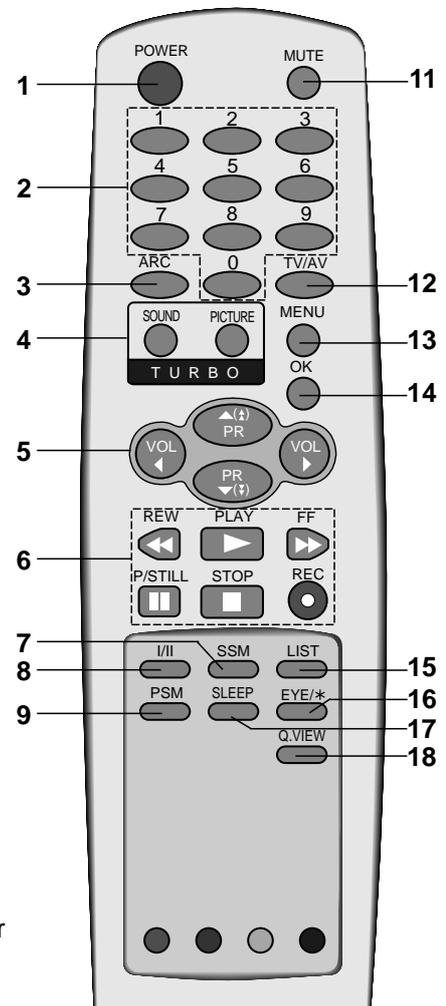

(Without TELETEXT / PIP)

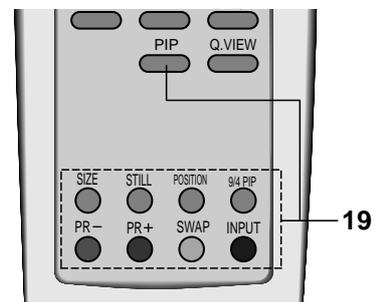

(Without TELETEXT / With PIP)

RF/RT-25/29CA40 series

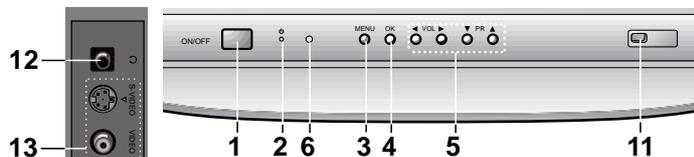

CF/CT-25/29M30 series

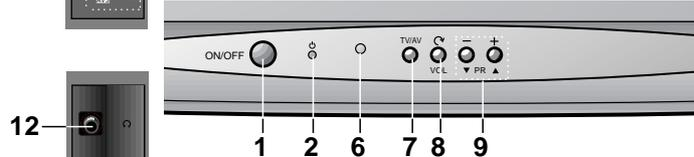

CF/CT-25/29Q40 series

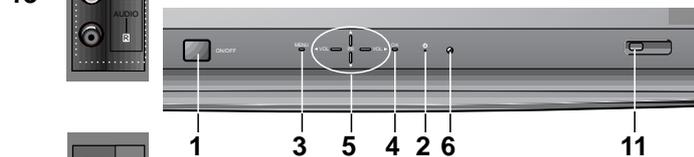

CF/CT-25/29K30 series



CF/CT-21/29Q90 series

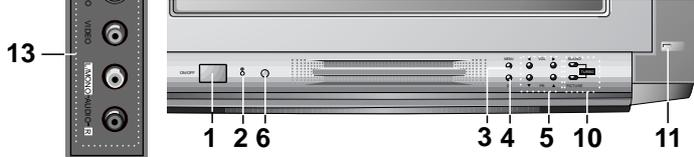

RF/RT-29FB50 series

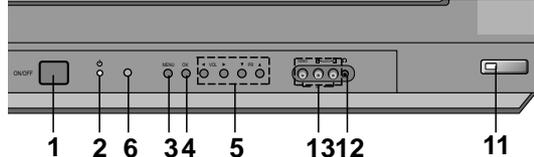

- 1. MAIN POWER**
switches the set on or off.
- 2. POWER/STANDBY INDICATOR**
illuminates brightly when the set is in standby mode.
dims when the set is switched on.
- 3. MENU**
selects a menu.
- 4. OK**
accepts your selection or displays the current mode.
- 5. ▲ / ▼ (Programme Up/Down)**
selects a programme or a menu item.
switches the set on from standby.
- ◀ / ▶ (Volume Down/Up)**
adjusts the volume.
adjusts menu settings.
- 6. REMOTE CONTROL SENSOR**
Note : Only use the supplied remote control handset. (When you use others, they'll be not able to function.)
- 7. TV/AV**
selects TV or AV mode.
clears the menu from the screen.
switches the set on from standby.
- 8. ⌚ (Function)**
selects volume, EYE (option), picture items or brief auto programme while the menus not display.
- 9. +/- (▲/▼)**
adjusts the function or selects a programme.
switches the set on from standby.
- 10. TURBO SOUND / PICTURE (option)**
switches Turbo sound or Turbo picture function on or off.
- 11. EYE (option)**
adjusts picture according to the surrounding conditions.
- 12. HEADPHONE SOCKET (option)**
Connect the headphone plug to this socket.
- 13. AUDIO/VIDEO IN SOCKETS (AV3)**
Connect the audio/video out sockets of external equipment to these sockets.
S-VIDEO/AUDIO IN SOCKETS (S-AV) (option)
Connect the video out socket of an S-VIDEO VCR to the **S-VIDEO** socket.
Connect the audio out sockets of the S-VIDEO VCR to the audio sockets as in **AV3**.

Note : Do not place any heavy objects (over 4Kg) on the RT-29FA33 series models..

DISASSEMBLY INSTRUCTIONS

Important note

This set is disconnected from the power supply through the converter transformer. An isolating transformer is necessary for service operations on the primary side of the converter transformer.

Back Cabinet Removal

Remove the screws residing on the back cabinet and carefully separate the back cabinet from the front cabinet. (Fig. 2-1).

CPT Removal

1. Pull out the CPT board from the CPT neck.
2. Place the front cabinet on soft material not to mar the front surface or damage control knobs.
3. Remove 4 screws securing the picture tube mounting brackets to the front cabinet.
4. Carefully separate CPT from the front cabinet.

Chassis Assy Removal

Grasp both side of Frame and pull it backward smoothly.

PICTURE TUBE HANDLING CAUTION

Due to high vacuum and large surface area of picture tube, great care must be exercised when handling picture tube. Always lift picture tube by grasping it firmly around faceplate. NEVER LIFT TUBE BY ITS NECK! The picture tube must not be scratched or subjected to excessive pressure as fracture of glass may result in an implosion of considerable violence which can cause personal injury or property damage.

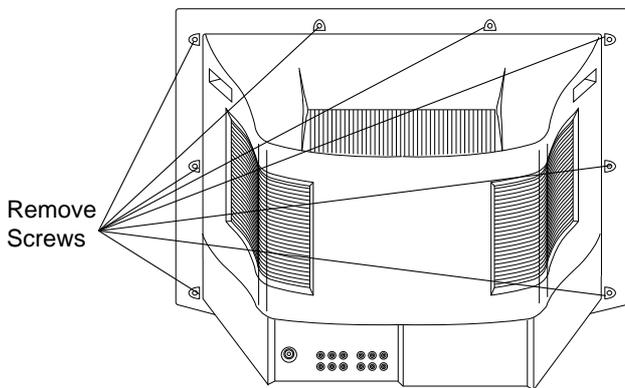

Fig. 2-1

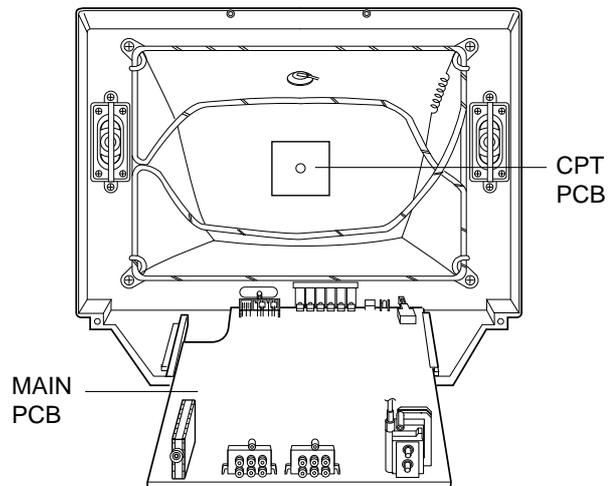

Fig. 2-2

ADJUSTMENT INSTRUCTIONS

1. Safety Precautions

1. It is safe to adjust after using insulating transformer between the power supply line and chassis input to prevent the risk of electric shock and protect the instrument.
2. Never disconnect leads while the TV receiver is on.
3. Don't short any portion of circuits while power is on.
4. The adjustment must be done by the correct appliances.
5. Unless otherwise noted, set the line voltage to 230Vac±10%, 50Hz.
6. The adjustment of TV should be performed after warming up for 15 minutes.

2. Test Equipment required

1. RF signal generator (with pattern generator)
2. DC Power Supply
3. Multimeter (volt meter)
4. Oscilloscope
5. Color analyzer

3. DVCO Adjustment

- 1) This is for adjustment of VCT38XX, crystal oscillator frequency after receiving a company Digital pattern.(PAL:EU05CH,NTSC:13CH)
- 2) When entering adjustment mode by pressing IN-START button,DVCO adjustment is operating automatically. (T/X doesn't operating occasionally during DVCO adjustment.)

4. Focus Adjustment

4-1. Preparation for Adjustment

Tune the TV set to receive a digital pattern.

4-2. Adjustment Method

1) Single Focus CPT

Adjust the upper Focus volume of FBT for the best focus of horizontal line A, vertical line B.

2) Double Focus CPT

- 1) Adjust the lower Focus volume of FBT for the best focus of vertical line B.
- 2) Adjust the upper Focus volume of FBT for the best focus of area A.
- 3) Repeat above step 1) and 2) for the best overall focus.

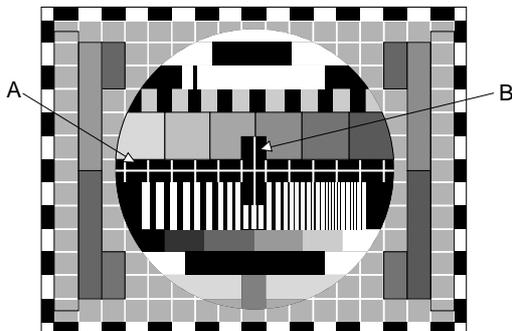

Fig. 1

5. Screen Voltage & White Balance Adjustment

5-1. Adjustment of screen manually (Using ADJ.Remote Control)

- 1) Receive the PAL or SECAM(NTSC) signal into RF mode regardless of channel.
- 2) If you press the "ADJ" button in LINE SVC mode(IN-START button), the LINE SVC mode changes to screen adjustment mode.
- 3) Turn the Screen Volume of FBT to change luminance of White signal center as shown below.(Deviation ± 1FL)
- 4) Press the EXIT button (Like TV/AV) to exit SVC mode.

CPT & INCH	Luminance(Manual)	Note
29" FLAT	6±1FL	Single Focus
25" FLAT	8±1FL	
29" NORMAL	5±1FL	
25" NORMAL	6±1FL	
28" NORMAL	8±1FL	

5-2. Adjustment of white balance manually(Line-SVC 1)

- 1) Tune the TV set to receive an 100% white pattern.
- 2) Adjust LOW Light status of CUT R,CUT B at CUT G:50.
- 3) Adjust HIGH Light status of WDR R,WDR B at WDR G:380.
- 4) Repeat above step 2) and 3) for the best condition each status of High Light and Low Light.

White Balance Color analyzer

Menu	EU	N-EU
X	288	268
Y	295	273
Color Temperature	9000°K	13000°K

White Balance Initial Data

Menu	Range	DATA
CUR R	0 ~ 511	50
CUR G	0 ~ 511	50
CUR B	0 ~ 511	50
WDR R	0 ~ 511	380
WDR G	0 ~ 511	380
WDR B	0 ~ 511	380

NOTE : When adjusting white balance automatically, connect the adjustment JIG in SVC mode.(When pressing IN-START,MUTE button on remote control for adjustment orderly,it changes to SVC mode and screen displays SVC.)

6. Deflection Data Adjustment (Line SVC-2)

NOTE : How to enter into the Line Service Mode with a remote con.

- 1.Power off.
- 2.Press the Red button.
- 3.Press the Green button.
- 4.Press the Yellow button.
- 5.Press the Cyan button.
- 6.Press the OK button.
- 7.Power On.

6-1. Preparation for Deflection Adjustment

- 1) At adjustment mode(IN-START button on remote control of adjustment),changed to LINE SVC 2 mode to adjust the deflection.
- 2) Press Channel UP/DOWN button for desirous function Adjustment.
- 3) Press Volume UP/DOWN button to adjust the data.
- 4) Tune the TV set to receive a Digital pattern.(PAL:05CH)

NOTE : If production line doesn't the production line of LG TV, receive available deflection adjustment pattern.

6-2. Adjustment Method

NOTE : First,adjust deflection at N50Hz,W50Hz,Z50Hz of PAL signal.Then adjust deflection at N60Hz,W60Hz,Z60Hz of NTSC signal.
In case of NTSC only model,adjust deflection of N60Hz,W60Hz,Z60Hz of NTSC signal.

Store the deflection adjustment data in EEPROM by using ENTER button before adjusting PIP position.

- 1) When adjusting a deflection,adjust N50Hz of PAL signal first and adjust a deflection at W50Hz,Z50Hz,N60Hz,W60Hz,Z60Hz of PAL signal.
- 2) Adjust a deflection as shown below
PAL 4:3=> PAL 16:9=>PAL ZOOM=>NTSC 4:3=>NTSC 16:9=>NTSC ZOOM.
- 3) After finishing deflection adjustment,press the ENTER button to enter or exit in SVC mode.

VL (Vertical Linearity)

Adjust so that the boundary line between upper and lower half is in accord with geometric horizontal center of the CPT.

VA (Vertical Amplitude)

Adjust so that the circle of a digital circle pattern may be located within the effective screen of the CPT.

SC (Vertical "S" Correction)

Adjust so that all distance between each horizontal lines are to be the same.

VS (Vertical Shift)

Adjust so that the horizontal center line of a digital circle pattern is in accord with geometric horizontal center of the CPT.

HS (Horizontal Shift)

Adjust so that the vertical center line of a digital circle pattern is in accord with geometric vertical center of the CPT.

EW (Horizontal Width)

Adjust to that a digital circle pattern looks like exact circle.

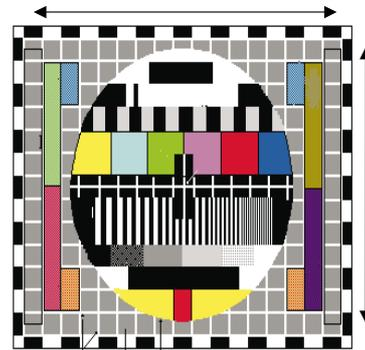

Fig. 2

EP (East-west Parabolar)

Adjust so that middle portion of the outermost left and right vertical line looks like parallel with vertical lines of the CPT.

EC (East-west Coner)

Adjust so that the vertical line at every 4 corners of the screen looks like parallel with the vertical lines of the CPT.

ET (East-west Trapezium)

Adjust to make the length of top horizontal line same with it of the bottom horizontal line.

PIP (PIP Position)

Adjust until the distance between PIP and main picture becomes about 1~2mm.

25/29" LG FLAT CPT(CT-25Q20RB)

ITEM	RANGE	N50Hz	W50Hz	Z50Hz
VA	0050~00CF	009A	22	11
VL	0025~00BF	00F3	3	0
SC	0000~009F	00D0	0	0
VS	0600~0900	0774	0	0
HS	0000~003F	0019	0	0
EW	0400~0EFF	0B96	22	0
ET	0700~08FF	07DE	0	0
EP	06E0~0840	07BF	19	-14
ES	06A0~0AFF	085C	0	0
EC	0790~08E0	082B	0	0
PIP P	0790~08E0	0007	0	0

29" S/S SEB FLAT CPT

ITEM	RANGE	N50Hz	W50Hz	Z50Hz
VA	0050~00CF	00A3	-22	11
VL	0025~00BF	00F5	0	0
SC	0000~009F	00D0	0	0
VS	0600~0900	0744	0	0
HS	0000~003F	0016	0	0
EW	0400~0EFF	0E40	0	0
ET	0700~08FF	07E9	0	0
EP	06E0~0840	07B4	22	-14
ES	06A0~0AFF	0840	0	0
EC	0790~08E0	0840	0	0
PIP P	0790~08E0	0000B	0	0

25/29" FST CPT

ITEM	RANGE	N50Hz		W50Hz		Z50Hz		N60Hz		W60Hz		Z60Hz	
		25"	29"	25"	29"	25"	29"	25"	29"	25"	29"	25"	29"
VA	0050~00CF	0092	008A	-22	-22	14	14	0	0	-22	-22	-5	-5
VL	0025~00BF	00FF	00F8	0	0	0	0	-5	-5	-5	-5	0	0
SC	0000~009F	00E1	00E1	0	0	0	0	0	0	0	0	0	0
VS	0600~0900	07FF	0733	0	0	0	0	43	43	43	43	43	43
HS	0000~003F	0016	001C	0	0	0	0	4	4	4	4	4	4
EW	0400~0EFF	0C36	0C59	0	0	0	0	15	15	15	15	15	15
ET	0700~08FF	07FC	07F3	0	0	0	0	-6	-6	-6	-6	-16	-16
EP	06E0~0840	07B3	07BF	25	25	-16	-16	-2	-2	15	15	-16	-16
ES	06A0~0AFF	0864	085F	29	29	29	29	0	0	44	44	44	44
EC	0790~08E0	083F	073E	0	0	0	0	12	12	12	12	12	12
PIP P	0790~08E0	0009	0009	0	0	0	0	0	0	0	0	0	0

28" LGPD FLAT CPT

ITEM	RANGE	16: 9		14: 9		ZOOM		STANDARD	
		50Hz	60Hz	50Hz	60Hz	50Hz	60Hz	50Hz	60Hz
VA	0050~00CF	0083	0083	008F	008E	00A7	00A7	0083	0084
VL	0025~00BF	00FD	00FA	00FD	00A	00FD	00F8	00FD	00F9
SC	0000~009F	00F0	00F0	00F0	00F0	00F0	00F0	00F0	00F0
VS	0600~0900	0729	0753	0732	0756	073B	075D	0741	0753
HS	0000~003F	0016	0014	0016	0014	0016	0014	0016	0014
EW	0400~0EFF	0A6E	0A62	0A6E	0A68	0A6E	0A68	0A6E	0A68
ET	0700~08FF	07FF	07FD	07FF	07E8	07FF	07EA	07FD	07EA
EP	06E0~0840	07B7	07B6	07A9	07AB	078E	078B	07B3	07B6

ITEM	RANGE	16: 9		14: 9		ZOOM		STANDARD	
		50Hz	60Hz	50Hz	60Hz	50Hz	60Hz	50Hz	60Hz
VA	0050~00CF	0083	0083	008F	008E	00A7	00A7	0083	0084
VL	0025~00BF	00FD	00FA	00FD	00A	00FD	00F8	00FD	00F9

7. SVC Data & PSM,SSM Data.

PICTURE SETTING DATA (LINE SVC-3)

Menu	Range	25/29" LG Flat	29" S/S-Flat	25" FST	28" FST	29" FST	28" FLAT
DVCO(Digital VCO)							
IBRM(BLACK CURRENT)	0~1FFH	00C8	00C8	00C8	00C8	00C8	00C8
WDRM(WHITE CURRENT)	0~3FFH	0190	0190	0190	0190	0190	0190
BCLT(BCL THERSHOLD)	0~7FFH	0055	0055	0050	0050	0050	0050
BCLTM(BCL TIME)	0~1FFH	0007	0007	0007	0007	0007	0007
BCLGA(BCL GAIN)	0~1FFH	0007	0007	0007	0007	0007	0007
SVGA(SVM GAIN)		000D	000D	000D	000D	000D	000D
SVDEL(SVM DELAY)		0007	0007	0007	0007	0007	0007
SVD1(SVM DELAY1)		0003	0003	0003	0003	0003	0003
LDLY(L DELAY)		FFFC	FFFE	FFFE	FFFE	FFFE	
DSCC(Discharge Sample)	0~01FF	000D	000D	0009		0007	0008
DSCV(Vertical Discharge)	0~01FF	FB80	FB80	FDC0		FD80	FB80

8. OPTION Adjustment (OPTION-1,2, 3,Teletext)

8-1. Preparation for Adjustment

- 1) This decides funtion in accordance with model.
Press the SVC TX adjustment button(IN-START button) at SVC mode,then adjust the option at OPTION 1,2,3,4 mode.
- 2) Mark the option adjustment data like [111,11,111,11] in BOM.

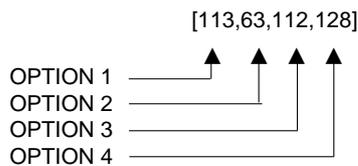

- Mark of BOM

LEVEL	PART NO.	SPECIFICATION	DESCRIPTION	JOB EXP.
1.	3141VMN382A	MAIN[MC-022A]	CHASSIS ASSY	OP[113,63,112,128]

The OPTION 1 data is 113,OPTION 2 data is 63,the oOPTION 3 data is 112,the OPTION 4 data is 128 in this model.

8-2. Adjustment Method

- 1) Input data directly by the buttons corresponded with OPTION1 ??(0~255), OPTION2 ??(0~255), OPTION3 ???(0~127),OPTION 4 ???(0~255).
- 2) Select each OPTION function by the CH Up/Down button and then set up each OPTION by the VOL Up/Down button.

8-3. OPTION 1 Function

Option	Code	Function	Remark
WIDE	0	4:3 NORMAL MODEL	
	1	WIDE FLAT MODEL	
TOP	0	W/O TOP(FLOP BASIC)	
	1	WITH TOP	
ACMS	0	Without ACMS funtion	Only Austrailia
	1	With ACMS funtion	
CH+AU	0	ALL NATION	
	1	Frequency Table	
EYE	0	WITHOUT EYE	
	1	WITH EYE	
DEG	0	Without DEGAUSSING	
	1	With DEGAUSSING	
TILT	0	WITHOUT TILT	
	1	WITH TILT	
KEY	0	6 KEY	
	1	4KEY(H80,K90,K30)	

8-5. OPTION 3 Function

Option	Code	Function	Remark
GAME	0	W/O GAME	TXT Model
	1	GAME PACK GAME(HINDI MICOM)	W/O TXT Model
MONO	0	FORCED MONO NOT SETTING	
	1	FORCED MONO SETTING	
AV2	0	WITH 1 AV JACK(BACK)	PAL model ALL
	1	WITH 2 AV JACK(BACK)	
TBS	0	BOOSTER CONTROL disable	1 TUNER Model
	1	BOOSTER CONTROL enable	2 PIP only
WOOF	0	W/O WOOFER	
	1	WITH WOOFER	
PIP	0	1 TUNER PIP or W/O PIP	1 PIP or W/O PIP
	1	2 TUNER PIP	2 PIP
SYS	0	B/G,I,D/K	CE/RE-MODEL
	1	B/G,I,D/K,L/L'	CL/RL-MODEL
	2	B/G,I,D/K,M	CT/RT-MODEL
	3	RESERVED	

8-4. OPTION 2 Function

Option	Code	Function	Remark
TURBO	0	Without TURBO search	EU
	1	With TURBO search	
C MUTE	0	Not CARRIER MUTE	MONO MODEL
	1	CARRIER MUTE	DEFAULT
A2 ST	0	NICAM	
	1	NICAM & FM STEREO	
DUAL	0	NO SAVE DUAL/SOUND Condition	EU(CE,CL Model)
	1	SAVE DUAL SOUND Condition	NON EU(CT Model)
SCART	0	PHONE JACK	
	1	SCART JACK	
V-CUR	0	NORMAL VOLUME CURVE	
	1	RUSHED VOLUME CURVE	
DVD	0	Without DVD INPUT	
	1	With DVD INPUT	
HOTEL	0	Without HOTEL OPTION	
	1	With HOTEL OPTION	
M-VOL	0~100	MAX VOLUME	With HOTEL mode

8-6. SOUND PRE-SCALER

Menu	DATA
FP(FM PRE-SCALER)	0016
NP(NICAM PRE-SCALER)	0056
SP(SCART PRE-SCALER)	0013
S1 VOL(SCART1 PRE-SCALER)	0064
S2 VOL(SCART2 PRE-SCALER)	0064
AGC-L(AUTO GAIN CONT.LIMIT)	00C5

8-7. OPTION 4 Function

OPTION	CODE	FUNTION	
OSD LANG.	0	English Only(Eng.)	Arab.Asia
	1	Arab(Eng/Fr/Arab)	3834
	2	Urdu(Eng/Fr/Arab/Urdu)	
	3	Asia(Eng/Fr/Indonesia)	
	0	English Only(Eng.)	Farsi
	1	Arab(Eng/Fr/Arab)	3834
	2	Farsi(Eng/Fr/Arab/Farsi)	
	0	English Only(Eng.)	Arab-Asia
	1	Arab(Eng/Fr/Arab)	3804
	2	Urdu(Eng/Fr/Arab/Urdu)	
	3	Arab all(Eng/Fr/Arab/Urdu/Farsi)	
	4	Farsi ONLY(Eng/Farsi)	
	5	Asia(Eng/Fr/Indonesia/Malay)	
	0	English Only(Eng.)	WEST-EU
	1	EU-7(E.Ger/Fr/Ita/Spain/Holand/Port)	3834 Only(W/TXT)
	2	EU-NORTH(E-Ger/Fr/Holand/Swe/Nor/Den/Fin)	
	0	English Only(Eng.)	EAST-EU
	1	Cyrilic(E.Russia)	3834 Only(W/TXT)
	2	EU-EAST(E.Ger/Rum/Pin/Hung/Chez)	
	3	EU-EAST All(E-Ger/Rum/Pol/Hung/Chez/Russia)	
	0	English Only(Eng.)	EU-ALL
	1	EU-7(E.Ger/Fr/Ita/Spain/Holand/Port)	3804 Only(W/O TXT)
	2	EU-NORTH(E-Ger/Fr/Holand/Swe/Nor/Den/Fin)	
	3	Cyrilic(E.Russia)	
	4	EU-EAST(E.Ger/Rum/Pin/Hung/Chez)	
	5	EU-EAST All(E-Ger/Rum/Pol/Hung/Chez/Russia)	
	0	English Only(Eng.)	28" Wide Flat
	1	EU-5(E.Ger/Fr/Ita/Spain)	3834 Only(W/TXT)
	0	English Only(Eng.)	Hindi-China-Viet.
	1	Vietnam(E.Vietnam)	3804 Only(W/O TXT)
	2	Hindi(E.Hindi)	
	3	China(E.China)	
0	Eng/Spain/Port		
1	Spain/Port/Eng		
2	Port/Spain/Eng		
3	Eng/Fr		
0	KOrean Only	Korea Version	

OPTION	CODE	FUNTION	
TXT-L	0	WEST-EU	Farsi only 3834 only(W/TXT)
	1	EAST-EU	
	2	Turkey	
	3	Cyrillic3	
	5	Arab/English	
	8	Farsi/English	
	0	WEST-EU	Arab-Asia 3834 only(W/TXT)
	1	EAST-EU	
	2	Turkey	
	3	Cyrillic3	
	5	Arab/English	
	0	WEST-EU	WEST EU 3834 only(W/TXT)
	1	EAST-EU	
	2	Turkey	
	6	Cyrillic3	
	0	WEST-EU	EAST EU 3834 only(W/TXT)
	1	EAST-EU	
	2	Turkey	
	6	Cyrillic3	
	0	WEST-EU	28" WIDE FLAT 3834 only(W/TXT)
1	EAST-EU		
2	Turkey		
4	Cyrillic3		
5	Arab/English		
6	Farsi/English		

BLOCK DIAGRAM

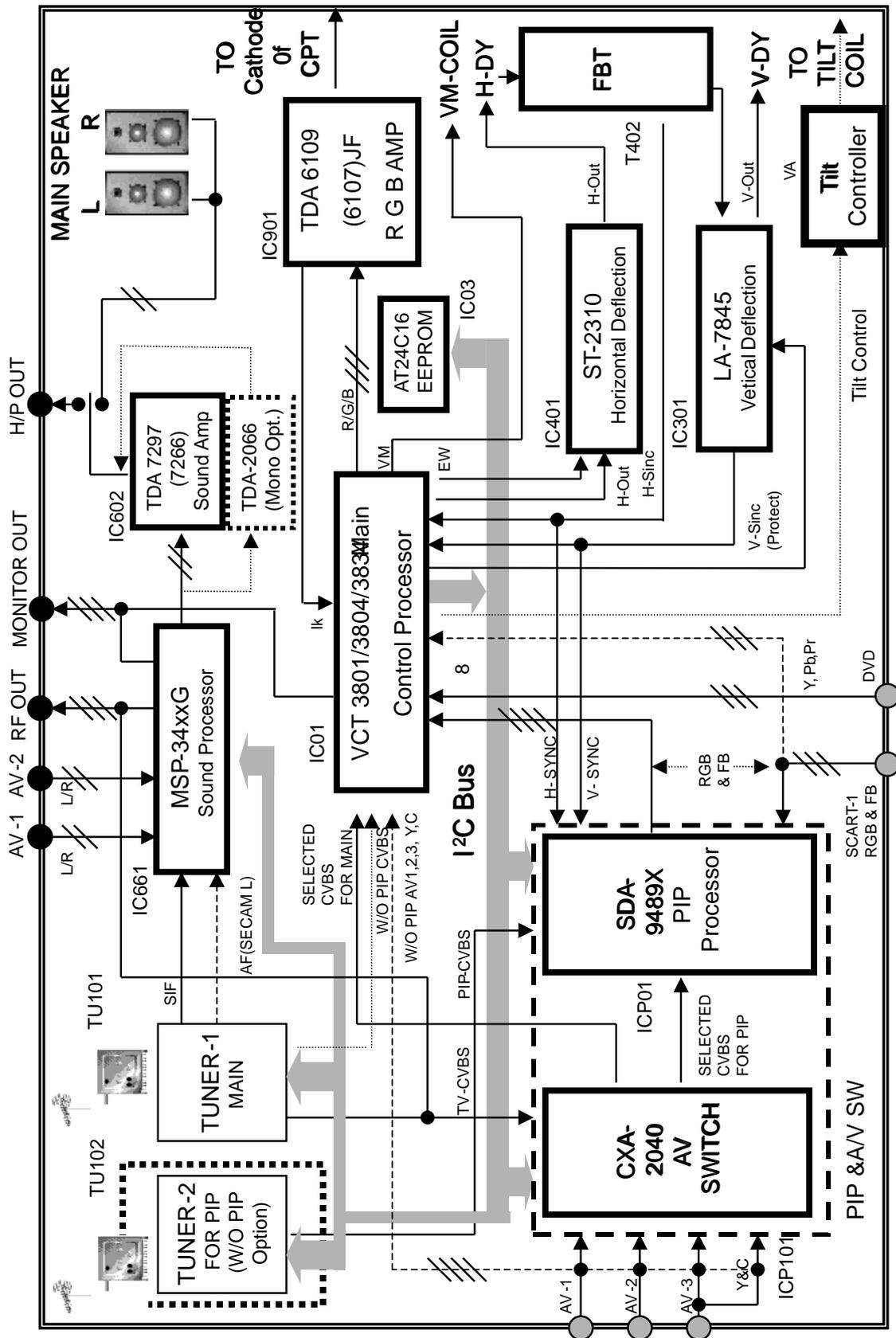

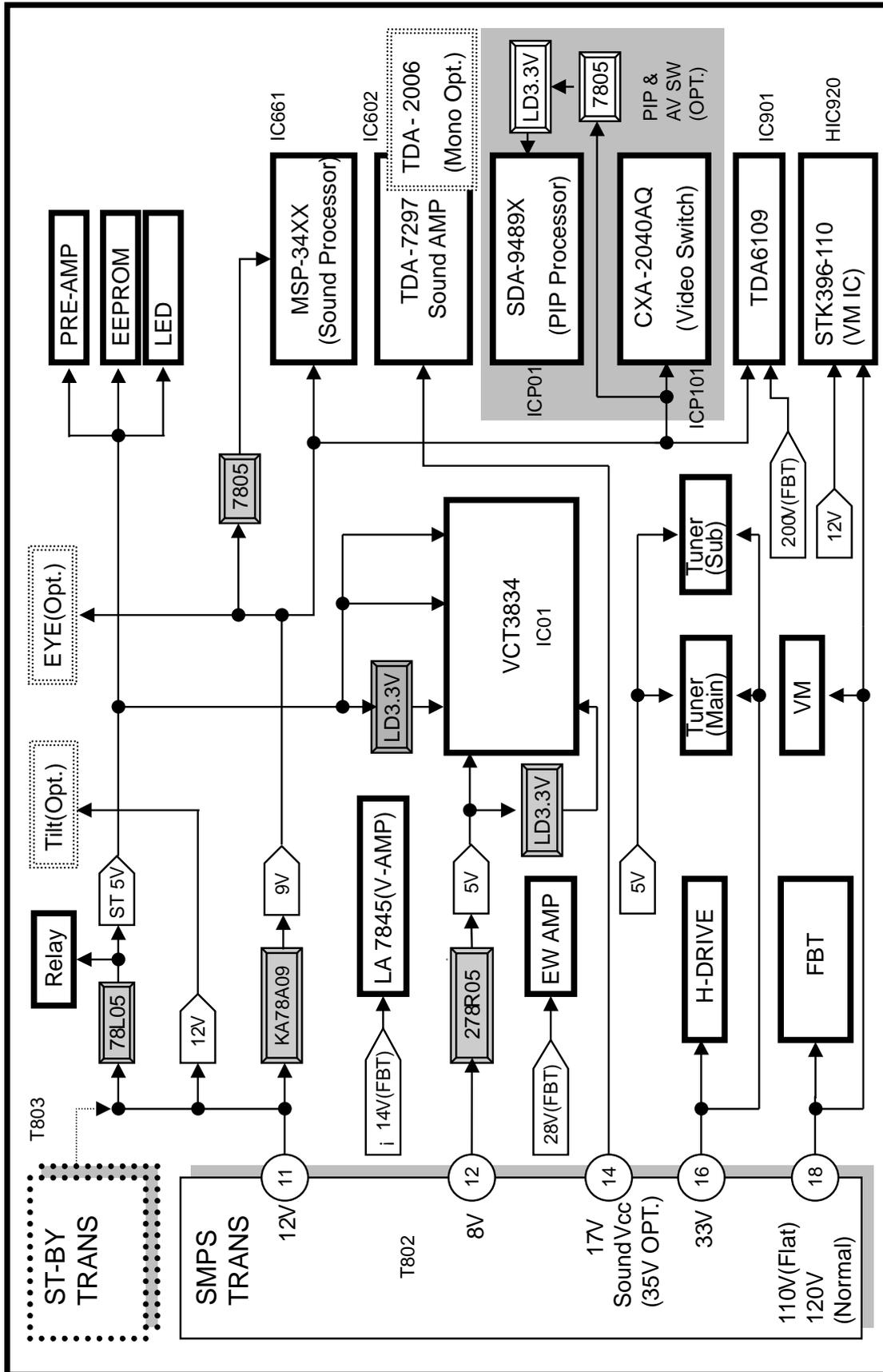

TROUBLE SHOOTING

RF - STEREO

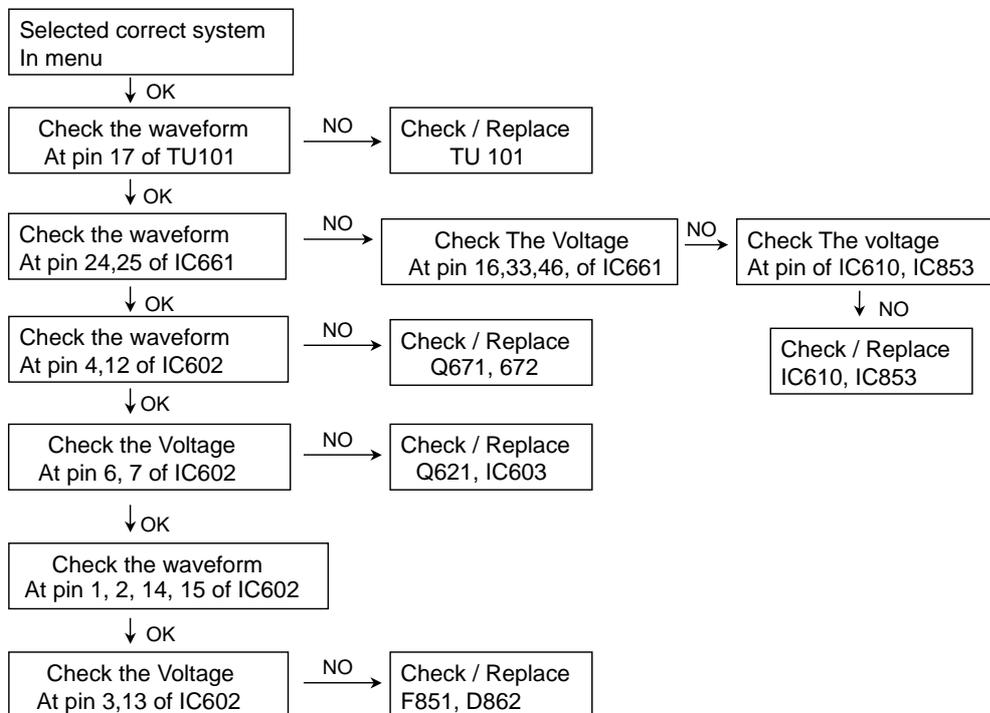

No Raster / Sound OK

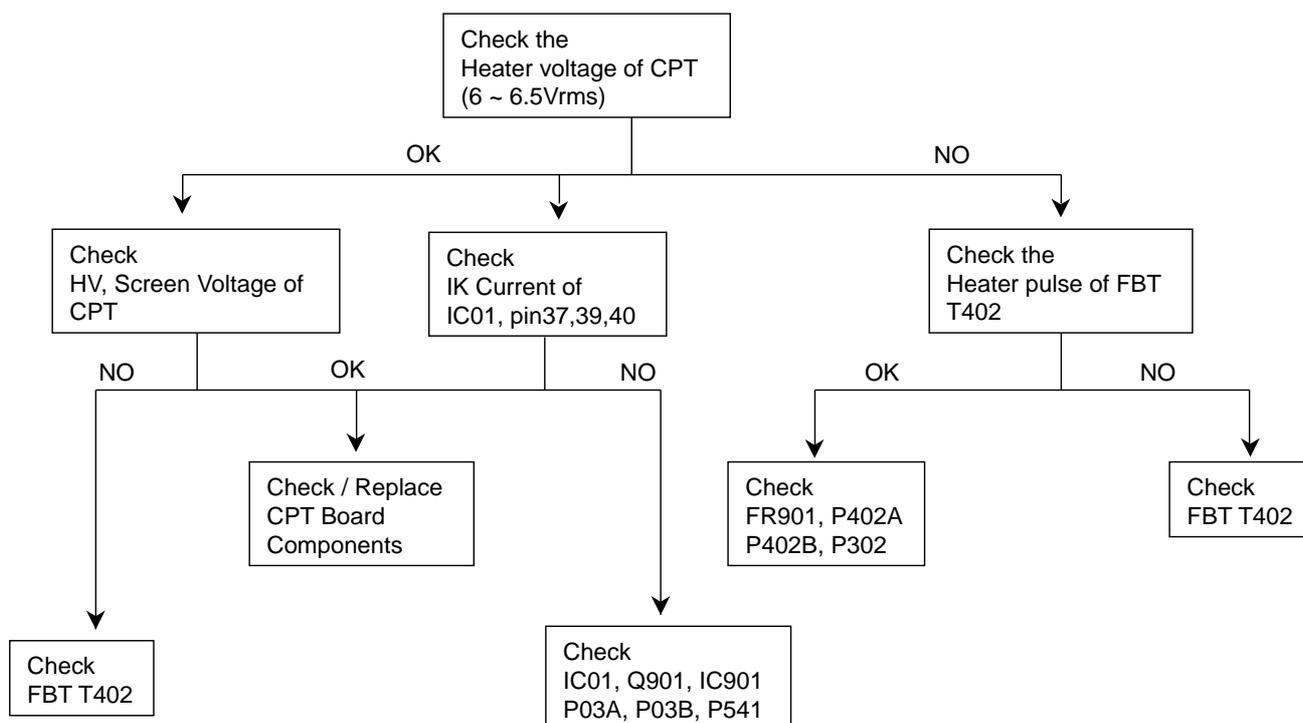

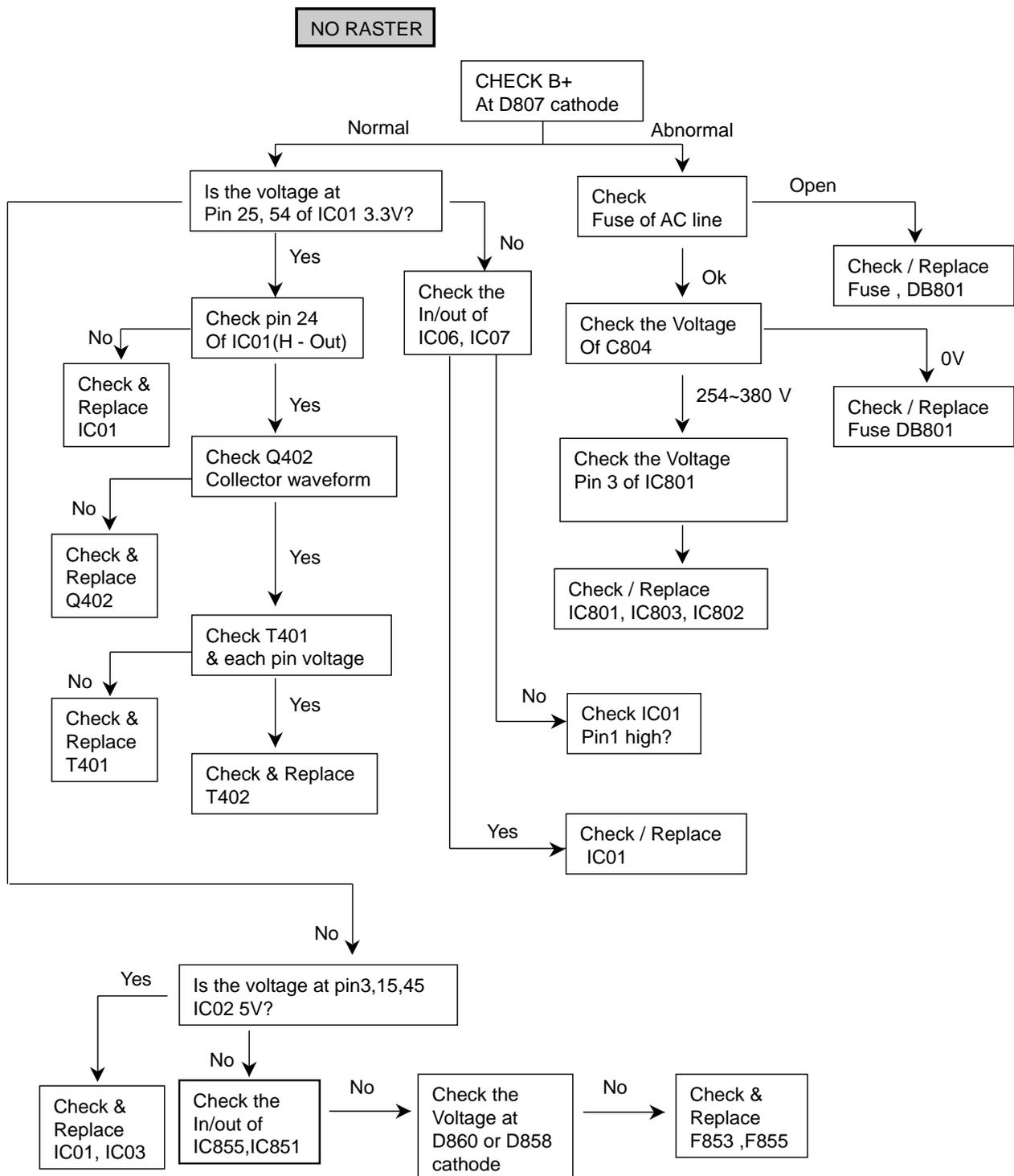

No Picture / No Sound

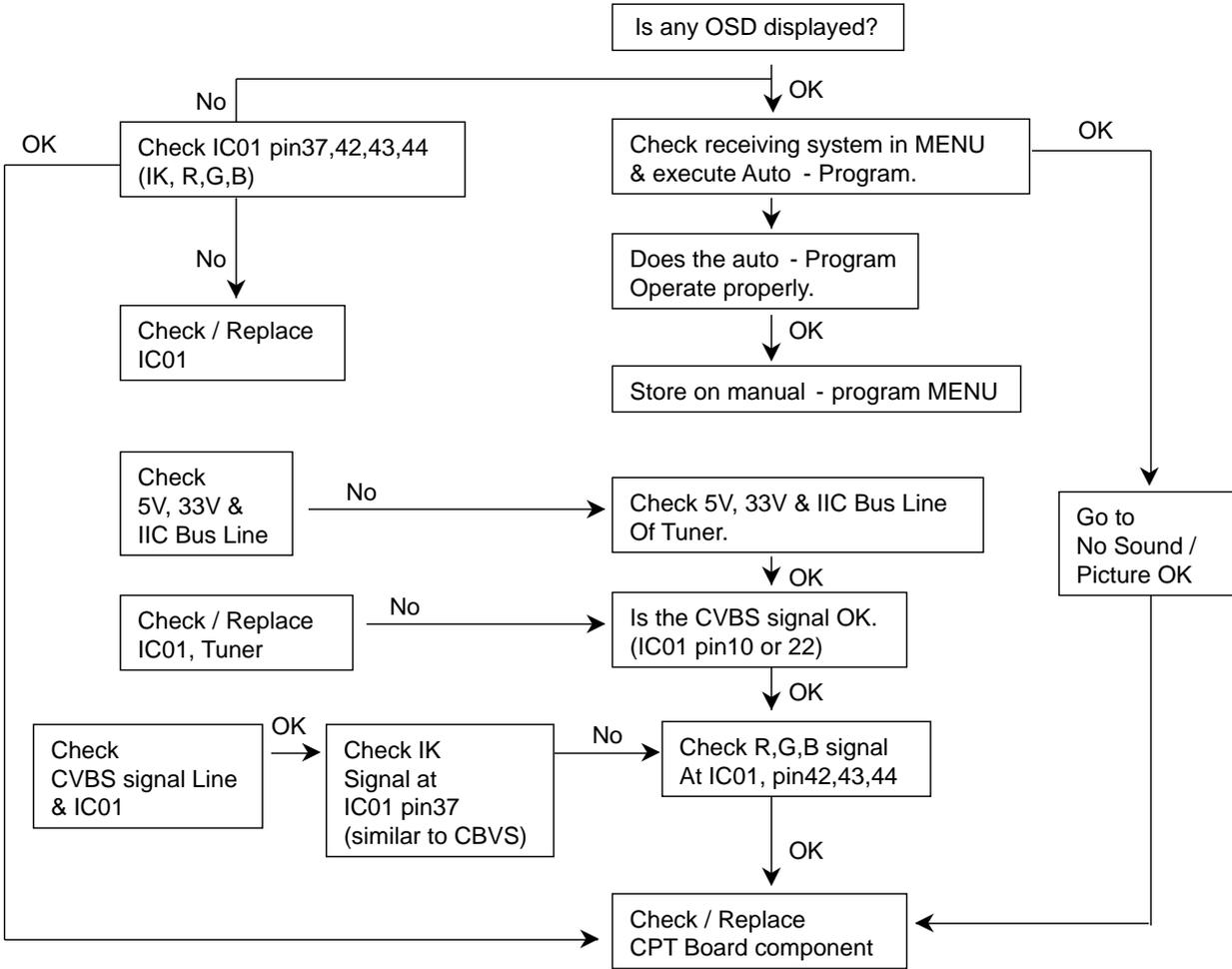

AV Stereo

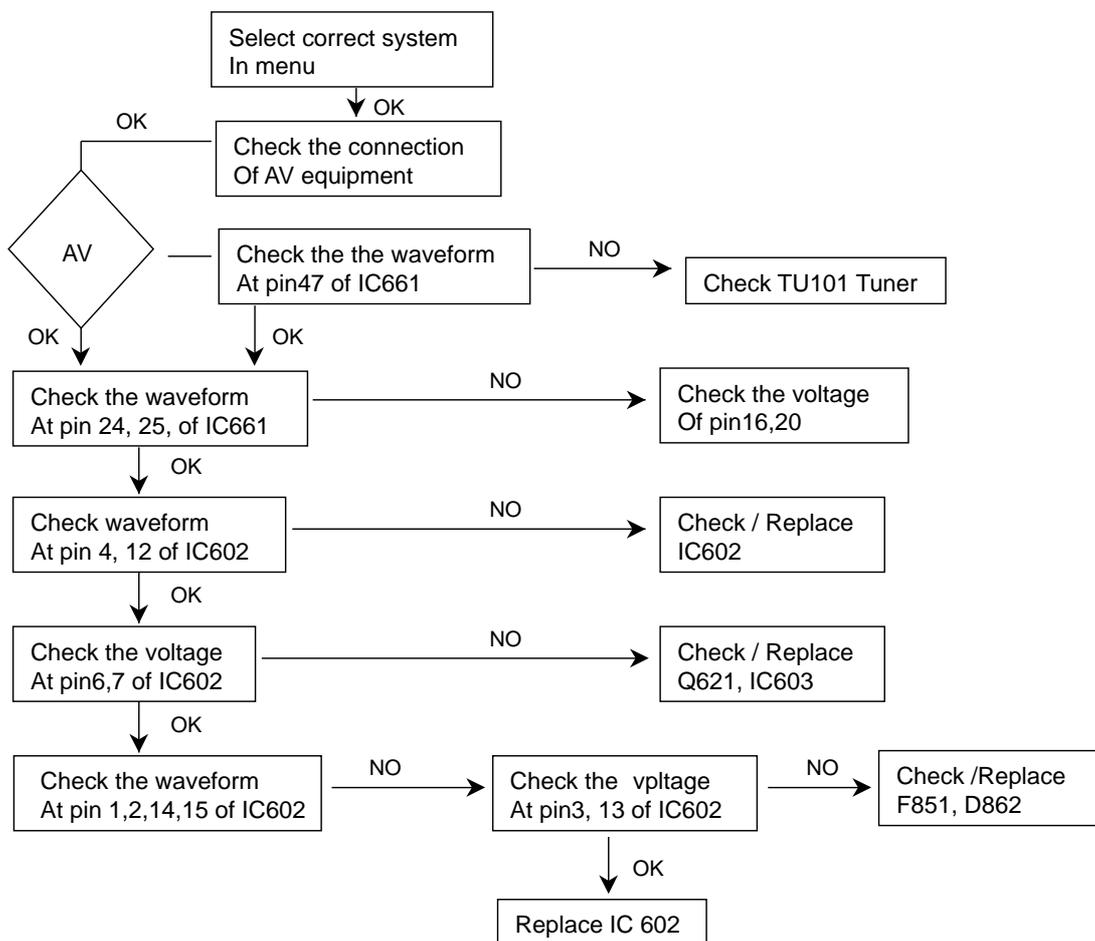

EXPLODED VIEW

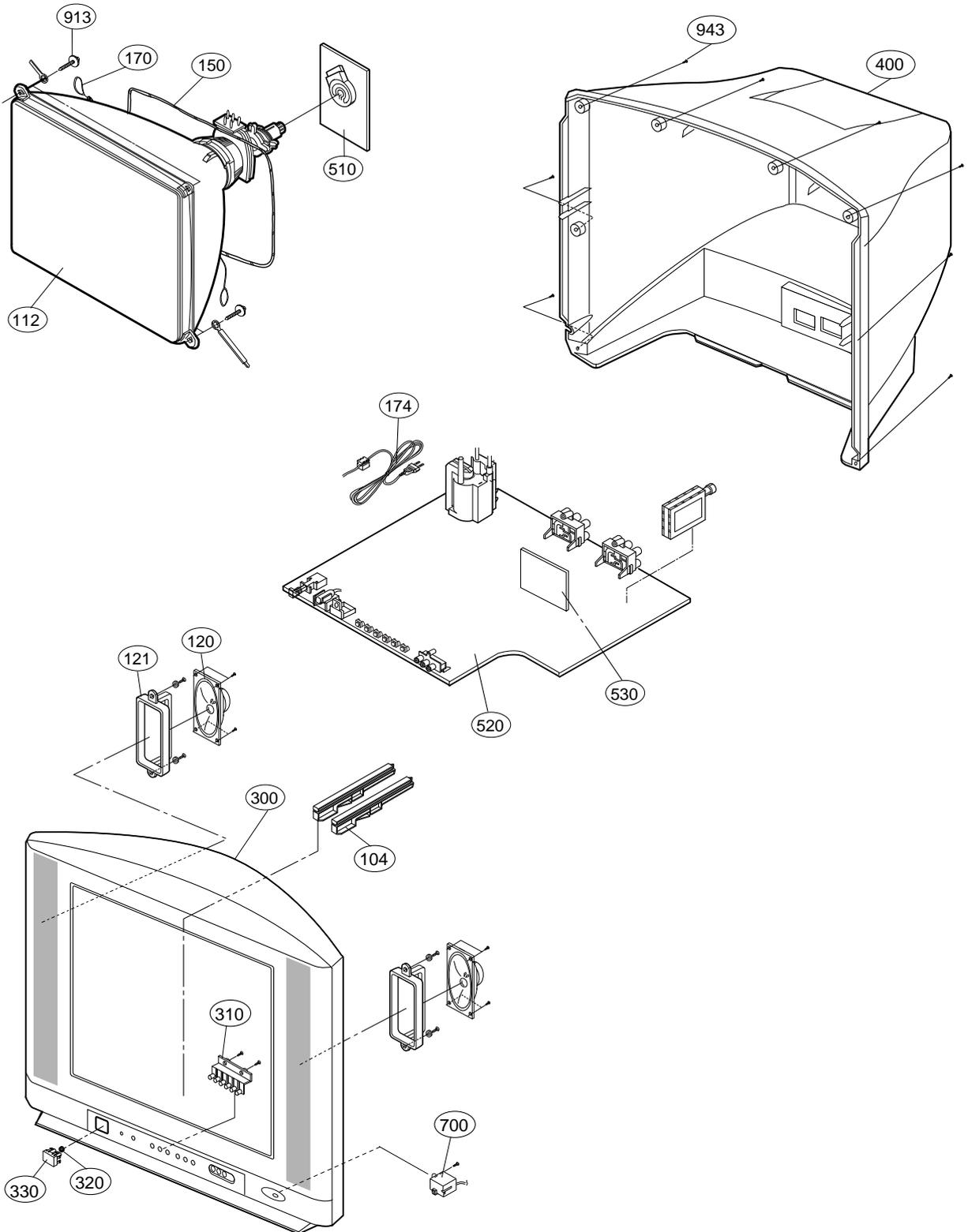

EXPLODED VIEW PARTS LIST

The components identified by mark Δ is critical for safety.
Replace only with part number specified.

LOCA. NO	PART NO	DESCRIPTIONS
104	343-B52A	SUPPORTER,PCB
Δ 112	6341V29009A	CPT ASSEMBLY,A68QCU759X ,5006C DY S-FOCUS
	6334V29003A	CPT
	6334V29003B	CPT
120	120-C77G	SPEAKER,FULLRANGE C122P02K1459 MOTOR JOY 8 OHM 10/15W
121	4810V00088A	BRACKET,SPEAKER
Δ 150	6140VC2005F	COIL,DEGAUSSING 29 FLAT ASSY (W) SELLA TECH 2001R+D07L
Δ 153	6150V-5006C	DY,DC29SFALJ
	6150V-5006D	DY,DC29SPFL3
Δ 170	170-844K	CPT EARTH 29 98T 4LUG LEAD SET SPRING(50MM)
300	3091V00445B	CABINET ASSEMBLY,RT-29FB50RB STEREO MC022A .
	3091V00472B	CABINET ASSEMBLY,RT-29FB50RE
	3091V00445C	CABINET ASSEMBLY,RT-29FB50RX
310	5020V00676A	BUTTON,CONTROL
	5020V00715A	BUTTON,CONTROL ABS
320	320-075B	SPRING,COIL NON DIA:7.5MM, H:15.5MM
	320-062E	SPRING,KNOB
330	5020V00677A	BUTTON,POWER
	5020V00716A	BUTTON,POWER ABS
400	3809V00A55B	BACK COVER ASSEMBLY 1SCART 1PHONE .
	3809V00A55C	BACK COVER ASSEMBLY 2PHONE C/SKD
	3809V00321A	BACK COVER ASSEMBLY 2PHONE
	3809V00321B	BACK COVER ASSEMBLY(40AF) 1SCART 1PHONE
	3809V00321C	BACK COVER ASSEMBLY
510	6871VSMB26C	PWB ASSEMBLY,CPT 022A (CPT/VM) 29 LG
	6871VSMD76B	PWB ASSEMBLY,CPT(SY-CKD) 022A
	6871VSMN22B	PWB ASSEMBLY,CPT 022A 29" LG FLAT
520	6871VMMD20A	PWB ASSEMBLY,MAIN MC022A RT-29FB50RB
	6871VMMD20B	PWB ASSEMBLY,MAIN MC022A RT-29FB50RP
	6871VMMD19X	PWB ASSEMBLY,MAIN MC022A RT-29FB50RE
	6871VMMD19W	PWB ASSEMBLY,MAIN MC022A RT-29FB50VE
	6871VMMD40A	PWB ASSEMBLY,MAIN MC022A RT-29FB50VB
	6871VMMD40B	PWB ASSEMBLY,MAIN MC022A RT-29FB50VE
	6871VMMD40C	PWB ASSEMBLY,MAIN MC022A RT-29FB50VE
	6871VMMN10F	PWB ASSEMBLY,MAIN MC022A RT-29FB50RX
530	6871VSMB25B	PWB ASSEMBLY,PIP 022A W/ F-AV,W/O S-JACK
	6871VSMN37A	PWB ASSEMBLY,PIP(SY-CKD)
700	0IGL120104C	IC,LG SEMICONDUCTOR CDS SENSOR MODULE(P1201-04C)
913	332-229H	SCREW,DRAWING HEXAGON HEAD
943	1PTF0403116	SCREW,TAP TITE(P)[TRUSS HEAD]
Δ P801	174-009V	POWER CORD(W/HOLD,HOUSING)L=400,4.0
	6410VEH001E	POWER CORD

REPLACEMENT PARTS LIST

LOCA. NO	PART NO	DESCRIPTION	LOCA. NO	PART NO	DESCRIPTION
IC					
HIC920	0IZZVF0018A	STK386-110 11P ST SCAN VELOCITY MODU. SINGLE SCAN (BW 6M)	"	0DR100009FA	DIODE,RECTIFIERS EU1DGR TP
IC01	0ICTMMN006B	VCT3834B LG28 MIDDLE ASIA MICRONAS 64P ST TXT MICOM	D803	0DD100009AM	DIODE,RECTIFIERS EU1ZV(1) TP SANKEN
IC01	0ICTMMN015A	VCT3804B LG15 MICRONAS	"	0DR100009FA	DIODE,RECTIFIERS EU1DGR TP
IC01	0ICTMMN011A	VCT3804B LG31	D804	0DD414809ED	DIODE,1N4148 TA
IC03	0IAL241610B	AT24C16A-10PI-2.7 8PIN DIP	"	0DS141489AB	DIODE,1N4148 TP GRADE 20V
IC06	0ISG111733B	LD1117V33C 3SIP ST REGULATOR	D815	0DD060009AC	DIODE,RECTIFIERS TVR06J TP 600V 250NSEC
IC07	0ISG111733B	LD1117V33C 3SIP ST REGULATOR	"	0DR060009AA	DIODE,RECTIFIERS TVR06J TP
IC09	0IFA752700A	KA75270Z 3 TP RE-SET IC MC-007	D857	0DD414809ED	DIODE,1N4148 TA
IC301	0ISA784500A	LA7845 7SIP V/OUT(1.5A)	"	0DS141489AB	DIODE,1N4148 TP GRADE 20V
IC302	0IKE455800E	KIA4558 8DIP DUAL OP AMP	D858	0DD420000BB	DIODE,D4L20U SHINDENGEN
IC602	0ISG729700A	TDA7297 15P,SIP BK 2CH 15W DUAL AMP	"	0DR200009DA	DIODE,RU2JGF
IC603	0IFA754207A	KA75420ZTA 3P,TO-92 TP 4.2V RESET IC	D860	0DD420000BB	DIODE,D4L20U SHINDENGEN
IC610	0IKE780500Q	KIA7805API 3P TO-220 ST REGULATOR 5V	D861	0DD060009AC	DIODE,RECTIFIERS TVR06J TP 600V 250NSEC
IC661	0IMCRMN011C	MSP3410G PO B8 V3 MICRONAS 52P DIP ST SOUND	"	0DR060009AA	DIODE,RECTIFIERS TVR06J TP
"	0IIT346000B	MSP3460G PO B8 V3 52P DIP	D862	0DD420000BB	DIODE,D4L20U SHINDENGEN
IC662	0IFA753307A	KA75330ZTA 3P,TO-92 TP 3.3V RESET IC	D863	0DD414809ED	DIODE,1N4148 TA
IC801	0IMCRSK001A	STR-F6456R SANKEN 5PIN(LF1352) BK STR	"	0DS141489AB	DIODE,1N4148 TP GRADE 20V
IC802	0IL1817000G	LTV817M-VB 4P,DIP BK PHOTO COU	D864	0DD414809ED	DIODE,1N4148 TA
IC803	0IL1817000G	LTV817M-VB 4P,DIP BK PHOTO COU	"	0DS141489AB	DIODE,1N4148 TP GRADE 20V
IC851	0IKE780500P	KIA7805BP(AT) 3P 5V,150MA - - -	D865	0DS113379BA	DIODE,SWITCHING 1SS133 T-72 TP DO34 90V
IC853	0IMCRKE002A	KIA78R09PI KEC 4PIN,TO220IS-4 ST 1A LOW	D866	0DD410000AD	DIODE,RECTIFIERS RU4AM,LF-L1
IC855	0IMCRKE006A	KIA278R05PI KEC TO220IS,4P ST 2A LOW	"	0DR400009AB	DIODE,RECTIFIERS RU4JGF
IC856	0ISK110000A	SE110N(LF12) 3P 110V ERROR AMP	D867	0DD414809ED	DIODE,1N4148 TA
IC901	0IMCRPH009A	TDA6109JF PHILIPS 9SIP ST RGB	"	0DS141489AB	DIODE,1N4148 TP GRADE 20V
ICP01	0ISM948900A	SDA9489 28PIN SOP TP PIP	D901	0DR210009AC	DIODE,RECTIFIERS BAV21 200V 0.2A 1A 50SEC 100A
ICP02	0ISG111733B	LD1117V33C 3SIP ST REGULATOR	D902	0DR210009AC	DIODE,RECTIFIERS BAV21 200V 0.2A 1A 50SEC 100A
ICP03	0IKE780500Q	KIA7805API 3P TO-220 ST REGULATOR 5V	D903	0DR210009AC	DIODE,RECTIFIERS BAV21 200V 0.2A 1A 50SEC 100A
ICP101	0ISO204000A	CXA2040AQ 32P,QFP BK IIC BUS VIDEO S/W	D904	0DR140049AC	DIODE,RECTIFIERS 1N4004A T-81 TP ROHM-KOREA
DIODE			D920	0DD060009AC	DIODE,RECTIFIERS TVR06J TP 600V 250NSEC
D110	0DD414809ED	DIODE,1N4148 TA	"	0DR060009AA	DIODE,RECTIFIERS TVR06J TP
"	0DS141489AB	DIODE,1N4148 TP GRADE 20V	DB801	0DD560000AA	DIODE,RECTIFIER D5SB60 BRIDGE (5A/600V)
D180	0DD414809ED	DIODE,1N4148 TA	LD01	4930V00048A	HOLDER DIODE,LED ASSY
"	0DS141489AB	DIODE,1N4148 TP GRADE 20V	ZD101	0DZ330009DG	DIODE,ZENERS GDZJ33B TP GRANDE DO34 0.5W 33.0V
D181	0DD414809ED	DIODE,1N4148 TA	ZD102	0DZ620009AK	DIODE,ZENERS GDZJ6.2B TP GRAND
"	0DS141489AB	DIODE,1N4148 TP GRADE 20V	ZD121	0DZ330009DG	DIODE,ZENERS GDZJ33B TP GRANDE DO34 0.5W 33.0V
D301	0DD150009CA	DIODE,RECTIFIERS RGP15J TP	ZD302	0DZ510009BF	DIODE,ZENERS GDZ5.1B TP GRANDE DO34 0.5W 5.1V 0.02A
"	0DR150009EA	DIODE,RECTIFIERS RGP15J TP	ZD303	0DZ180009BE	DIODE,ZENERS GDZJ18B TP GRANDE DO34 0.5W 18.0V
D302	0DS113379BA	DIODE,SWITCHING 1SS133 T-72 TP ROHM	ZD401	0DZ510009BF	DIODE,ZENERS GDZ5.1B TP GRANDE DO34 0.5W 5.1V 0.02A
D401	0DD410000AG	DIODE,RECTIFIERS RS4FS R4 1500V 2.5A 50A 1.0USEC 50UA	ZD402	0DZ110009AD	DIODE,ZENERS MTZJ11B TP ROHM-K DO34 - 11V 5UA
D402	0DD410000AD	DIODE,RECTIFIERS RU4AM,LF-L1	"	0DZ110009CF	DIODE,ZENERS GDZJ11B TP GRADE
"	0DR400009AB	DIODE,RECTIFIERS RU4JGF TP	ZD501	0DZ510009BF	DIODE,ZENERS GDZ5.1B TP GRANDE DO34 0.5W 5.1V 0.02A
D403	0DD150009CA	DIODE,RECTIFIERS RGP15J TP	ZD601	0DZ510009BF	DIODE,ZENERS GDZ5.1B TP GRANDE DO34 0.5W 5.1V 0.02A
"	0DR150009EA	DIODE,RECTIFIERS RGP15J TP	ZD610	0DZ910009BD	DIODE,ZENERS GDZJ9.1B TP GRANDE DO34 0.5W 9.1V
D404	0DD150009CA	DIODE,RECTIFIERS RGP15J TP	ZD910	0DZ470009EF	DIODE,ZENERS GDZJ4.7B GRANDE TP DO34 0.5W 4.7V 5MA
"	0DR150009EA	DIODE,RECTIFIERS RGP15J TP	ZD911	0DZ470009EF	DIODE,ZENERS GDZJ4.7B GRANDE TP DO34 0.5W 4.7V 5MA
D405	0DR150009AB	DIODE,RECTIFIERS RGP15G TP DO15 400V 1.5A	ZD912	0DZ470009EF	DIODE,ZENERS GDZJ4.7B GRANDE TP DO34 0.5W 4.7V 5MA
D406	0DR150009AB	DIODE,RECTIFIERS RGP15G TP DO15 400V 1.5A	TRANSISTOR		
D408	0DD060009AC	DIODE,RECTIFIERS TVR06J TP 600V 250NSEC	Q06	0TR198009BA	TR,2SA1980Y TP AUK - -
"	0DR060009AA	DIODE,RECTIFIERS TVR06J TP	Q103	0TR534309AA	TR,2SC5343Y TP AUK - -
D505	0DD414809ED	DIODE,1N4148 TA	Q108	0TR534309AA	TR,2SC5343Y TP AUK - -
"	0DS141489AB	DIODE,1N4148 TP GRADE 20V	Q110	0TR127009AA	TR,KTA1270-Y KEC TP TO92 50V 100MA
D506	0DD414809ED	DIODE,1N4148 TA	Q111	0TR534309AA	TR,2SC5343Y TP AUK - -
"	0DS141489AB	DIODE,1N4148 TP GRADE 20V	Q112	0TR534309AA	TR,2SC5343Y TP AUK - -
D802	0DD100009AM	DIODE,RECTIFIERS EU1ZV(1) TP SANKEN	Q180	0TR534309AA	TR,2SC5343Y TP AUK - -
			Q181	0TR198009BA	TR,2SA1980Y TP AUK - -
			Q182	0TR198009BA	TR,2SA1980Y TP AUK - -

For Capacitor & Resistors, the characters at 2nd and 3rd digit in the P/No. means as follows;

CC, CX, CK, CN : Ceramic	RD : Carbon Film
CQ : Polyester	RS : Metal Oxide Film
CE : Electrolytic	RN : Metal Film
	RF : Fusible

LOCA. NO	PART NO	DESCRIPTION
Q183	0TR534309AA	TR,2SC5343Y TP AUK - -
Q184	0TR534309AA	TR,2SC5343Y TP AUK - -
Q185	0TR198009BA	TR,2SA1980Y TP AUK - -
Q186	0TR198009BA	TR,2SA1980Y TP AUK - -
Q187	0TR534309AA	TR,2SC5343Y TP AUK - -
Q201	0TR198009BA	TR,2SA1980Y TP AUK - -
Q202	0TR198009BA	TR,2SA1980Y TP AUK - -
Q301	0TR534309AA	TR,2SC5343Y TP AUK - -
Q302	0TR205900AB	TR,KTD2059-Y TO-220IS KEC
Q303	0TR127409AB	TR,KTA1274-Y TO-92L TP KEC
Q401	0TRSG10001A	TR,SGS-T ST2310HI ST TO220 1500V 1MA
Q402	0TR223800AA	TR,KTC2238A-Y BK KEC - -
Q505	0TR534309AA	TR,2SC5343Y TP AUK - -
Q506	0TR198009BA	TR,2SA1980Y TP AUK - -
Q507	0TR198009BA	TR,2SA1980Y TP AUK - -
Q508	0TR198009BA	TR,2SA1980Y TP AUK - -
Q509	0TR534309AA	TR,2SC5343Y TP AUK - -
Q621	0TR534309AA	TR,2SC5343Y TP AUK - -
Q671	0TR198009BA	TR,2SA1980Y TP AUK - -
Q672	0TR198009BA	TR,2SA1980Y TP AUK - -
Q806	0TR102009AB	TR,KRC102M(KRC1202) KEC TP NA NA NA
Q807	0TR102009AB	TR,KRC102M(KRC1202) KEC TP NA NA NA
Q853	0TR127009AA	TR,KTA1270-Y KEC TP TO92 50V 100MA
Q855	0TR421009CB	TR,BF421L(AMMO)TO-92 TP PHILIPS
Q856	0TR102009AB	TR,KRC102M(KRC1202) KEC TP NA NA NA
Q856	0TR102009AB	TR,KRC102M(KRC1202) KEC TP NA NA NA
Q901	0TR198009BA	TR,2SA1980Y TP AUK - -
QP01	0TR387500AA	TR,CHIP 2SC3875S(ALY) KEC
QP02	0TR387500AA	TR,CHIP 2SC3875S(ALY) KEC
QP03	0TR387500AA	TR,CHIP 2SC3875S(ALY) KEC
QP04	0TR387500AA	TR,CHIP 2SC3875S(ALY) KEC
QP05	0TR387500AA	TR,CHIP 2SC3875S(ALY) KEC

CAPACITOR

C01	0CC0500K115	5P 50V D NP0 TS
C02	0CC0500K115	5P 50V D NP0 TS
C03	0CE335DK618	3.3UF STD 50V 20% FL TP 5
C04	0CN1020K519	1000P 50V K B TA52
C06	0CE107DF618	100UF STD 16V M FL TP5
C07	0CN1030F679	10000P 16V M Y TA52
C08	0CN1030F679	10000P 16V M Y TA52
C10	0CX4700K409	47P 50V J SL TA52
"	0CN8200K519	82P 50V K B
C102	0CX4700K409	47P 50V J SL TA52
C103	0CX4700K409	47P 50V J SL TA52
C104	0CN1030F679	10000P 16V M Y TA52
C105	0CN1030F679	10000P 16V M Y TA52
C106	0CN1030F679	10000P 16V M Y TA52
C107	0CN1030F679	10000P 16V M Y TA52
C108	0CE476DD618	47UF STD 10V 20% FL TP 5
C109	0CE475DK618	4.7UF STD 50V 20% FL TP 5
C11	0CE107DD618	100UF STD 10V M FL TP5
C110	0CE476DK618	47UF STD 50V M FL TP5
"	0CE475DK618	4.7UF STD 50V 20% FL TP5
C111	0CN1030F679	10000P 16V M Y TA52
C114	0CE476DD618	47UF STD 10V 20% FL TP 5

LOCA. NO	PART NO	DESCRIPTION
C120	0CN1030F679	10000P 16V M Y TA52
C121	0CE474DK618	0.4700UF STD 50V M FL TP5
C125	0CN1040K949	0.1M 50V Z F TA52
C127	0CN1030F679	10000P 16V M Y TA52
C130	0CN1030F679	10000P 16V M Y TA52
C14	0CE476DF618	47UF STD 16V M FL TP5
C16	0CN4720F569	4700P 16V K X TA52
C17	0CE106DK618	10UF STD 50V M FL TP5
C180	0CN1020K519	1000P 50V K B TA52
C181	0CN2210K519	220P 50V K B TA52
C183	0CN1040K949	0.1M 50V Z F TA52
C184	0CE105DK618	1UF STD 50V M FL TP5
C200	0CN1010K519	100P 50V K B TA52
C201	0CE227DF618	220UF STD 16V M FL TP5
C202	0CN1010K519	100P 50V K B TA52
C205	0CN1010K519	100P 50V K B TA52
C206	0CN1010K519	100P 50V K B TA52
C207	0CN2210K519	220P 50V K B TA52
C209	0CN1050K949	1UF D 50V 80%,-20% F(Y5V) TA52
C210	0CE227DF618	220UF STD 16V M FL TP5
C211	0CN4710K519	470P 50V K B TA52
C213	0CN4710K519	470P 50V K B TA52
C215	0CN4710K519	470P 50V K B TA52
C216	0CN4710K519	470P 50V K B TA52
C22	0CE476DF618	47UF STD 16V M FL TP5
C22	0CE107DD618	100UF STD 10V M FL TP5
C227	0CE226DF618	22UF STD 16V M FL TP5
C228	0CE226DF618	22UF STD 16V M FL TP5
C229	0CE226DF618	22UF STD 16V M FL TP5
C23	0CE107DD618	100UF STD 10V M FL TP5
C230	0CE226DF618	22UF STD 16V M FL TP5
C232	0CN2210K519	220P 50V K B TA52
C24	0CE475DK618	4.7UF STD 50V 20% FL TP 5
C240	0CN2210K519	220P 50V K B TA52
C241	0CN2210K519	220P 50V K B TA52
C242	0CE106DF618	10UF STD 16V M FL TP5
C244	0CN2210K519	220P 50V K B TA52
C245	0CN4710K519	470P 50V K B TA52
C246	0CN4710K519	470P 50V K B TA52
C248	0CN4710K519	470P 50V K B TA52
C249	0CN4710K519	470P 50V K B TA52
C25	0CN1040K949	0.1M 50V Z F TA52
C27	0CE476DF618	47UF STD 16V M FL TP5
C28	0CN1030F679	10000P 16V M Y TA52
C29	0CE107DD618	100UF STD 10V M FL TP5
C30	0CE226DF618	22UF STD 16V M FL TP5
C30	0CE476DD618	47UF STD 10V 20% FL TP 5
C301	0CQ1031N509	0.01U 100V K POLY TP
C302	0CQ3341N401	0.33U 100V J POLY F5
C303	0CE107BK618	100UF KME 50V M FL TP5
C304	0CQ6821N509	0.0068U 100V K POLY TP
C305	0CQ1021N509	0.001U 100V K POLY TP
C306	0CQ3331N509	0.033U 100V K POLY TP
C308	0CE476DK618	47UF STD 50V M FL TP5
C309	0CN4710K519	470P 50V K B TA52
C310	0CQ1031N509	0.01U 100V K POLY TP

For Capacitor & Resistors, the characters at 2nd and 3rd digit in the P/No. means as follows;	CC, CX, CK, CN : Ceramic CQ : Polyester CE : Electrolytic	RD : Carbon Film RS : Metal Oxide Film RN : Metal Film RF : Fusible
---	---	--

LOCA. NO	PART NO	DESCRIPTION	LOCA. NO	PART NO	DESCRIPTION
C311	0CQ1031N509	0.01U 100V K POLY TP	"	181-007F	ECQ-V1H224JL3,50V
C401	0CE474DK618	0.4700UF STD 50V M FL TP5	C650	0CN1030F679	10000P 16V M Y TA52
C401	0CE105DK618	1UF STD 50V M FL TP5	C651	0CN1030F679	10000P 16V M Y TA52
C402	0CE475DK618	4.7UF STD 50V 20% FL TP 5	C663	0CE107DD618	100UF STD 10V M FL TP5
C403	0CQ1521N509	0.0015U 100V K POLY TP	C666	0CE335DK618	3.3UF STD 50V 20% FL TP 5
C405	181-015Q	0.02UF 1.6KV H M/PP NI FM20	C667	0CN3320F569	3300P 16V K X TA52
C406	181-091Y	R 680PF 2KV 10%,-10% R/TP TP7.5	C668	0CN3320F569	3300P 16V K X TA52
C407	181-010A	PP 400V 0.022UF J	C670	0CE106DK618	10UF STD 50V M FL TP5
C408	0CE6851K652	6.8UF SM,SA 50V 20% FM7.5 BP(S)	C670	0CE105DK618	1UF STD 50V M FL TP5
C409	0CK2220W515	2200P 500V K B TS	C671	0CE107DD618	100UF STD 10V M FL TP5
C410	0CE105CR636	1UF SHL,SD 250V 20% BP(D) TP FM5	C672	0CE106DK618	10UF STD 50V M FL TP5
C411	0CF5341U460	0.53UF D 400V 5% BULK M/PP	C672	0CE105DK618	1UF STD 50V M FL TP5
"	0CF5641U470	0.56UF D 400V 5%	C673	0CF3341L438	0.33UF D 63V 5% TP 5 M/PE NI
C413	0CE107DJ618	100UF STD 35V M FL TP5	"	181-007G	ECQ-V1H334JL3
C415	0CE108DH618	1000UF STD 25V M FL TP5	C674	0CF3341L438	0.33UF D 63V 5% TP 5 M/PE NI
C416	181-009R	PP 200V 0.022UF K	"	181-007G	ECQ-V1H334JL3
C419	0CE108DH618	1000UF STD 25V M FL TP5	C675	0CE106DF618	10UF STD 16V M FL TP5
C420	181-010B	PP 400V 0.056UF J	C676	0CF3341L438	0.33UF D 63V 5% TP 5 M/PE NI
C422	0CE475DR618	4.7UF STD 250V 20% FL TP 5	"	181-007G	ECQ-V1H334JL3
C501	0CE107DD618	100UF STD 10V M FL TP5	C677	0CF3341L438	0.33UF D 63V 5% TP 5 M/PE NI
C502	0CN1040K949	0.1M 50V Z F TA52	"	181-007G	ECQ-V1H334JL3
C503	0CN1050K949	1UF D 50V 80%,-20% F(Y5V) TA52	C678	0CF3341L438	0.33UF D 63V 5% TP 5 M/PE NI
C504	0CN1050K949	1UF D 50V 80%,-20% F(Y5V) TA52	"	181-007G	ECQ-V1H334JL3
C505	0CN1040K949	0.1M 50V Z F TA52	C679	0CF3341L438	0.33UF D 63V 5% TP 5 M/PE NI
C506	0CN1040K949	0.1M 50V Z F TA52	"	181-007G	ECQ-V1H334JL3
C508	0CN1050K949	1UF D 50V 80%,-20% F(Y5V) TA52	C681	0CE106DF618	10UF STD 16V M FL TP5
C509	0CN1050K949	1UF D 50V 80%,-20% F(Y5V) TA52	C682	0CF3341L438	0.33UF D 63V 5% TP 5 M/PE NI
C510	0CN1020K519	1000P 50V K B TA52	C685	0CE106DF618	10UF STD 16V M FL TP5
"	0CN1010K519	100P 50V K B TA52	C686	0CX5600K409	56P 50V J SL TA52
C511	0CN1050K949	1UF D 50V 80%,-20% F(Y5V) TA52	C687	0CX5600K409	56P 50V J SL TA52
C512	0CN1010K519	100P 50V K B TA52	C688	0CX5600K409	56P 50V J SL TA52
C513	0CN1050K949	1UF D 50V 80%,-20% F(Y5V) TA52	C689	0CC0200K115	2P 50V D NP0 TS
C514	0CN1050K949	1UF D 50V 80%,-20% F(Y5V) TA52	C690	0CC0200K115	2P 50V D NP0 TS
C515	0CN1050K949	1UF D 50V 80%,-20% F(Y5V) TA52	C802	0CQZVBK002C	A.C 275V 0.22UF K (S=22.5)
C516	0CN1030F679	10000P 16V M Y TA52	"	181-506J	ECQ-U 2A224KVA 0.22UF 250V
C517	0CQ6831N509	0.068U 100V K POLY TP	C803	181-091U	R 220PF 2KV 10%,-10% R/TP TP7.5
C518	0CQ6831N509	0.068U 100V K POLY TP	C804	0CE337KV6A0	330UF SLT 450V M VNSN BULK
C520	0CN1020K519	1000P 50V K B TA52	C806	181-014Y	MPP 1.6KV 0.0015UF J
C521	0CN1010K519	100P 50V K B TA52	C807	0CK4710K515	470PF 50V K B TR
C522	0CN1010K519	100P 50V K B TA52	C808	0CE107BJ618	100UF KME 35V M FL TP5
C523	0CN1010K519	100P 50V K B TA52	C809	181-091D	DEHR33A102KN2A 1000PF 1KV 10%,-10%
C559	0CQ6831N509	0.068U 100V K POLY TP	C813	0CK10201515	1000P 1KV K B TS
C561	0CQ2242K439	0.22UF S 50V 5% M/PE NI TP5	C814	0CQZVBK002A	A.C 275V 0.1UF M (S=15)
C562	0CN2210K519	220P 50V K B TA52	"	181-506K	ECQ-V2A104MVA 0.1UF D 250
C563	0CN2210K519	220P 50V K B TA52	C815	181-091C	DEHR33A471KN2A 470PF 1KV 10%,-10%
C564	0CN2210K519	220P 50V K B TA52	C816	0CK10201515	1000P 1KV K B TS
C565	0CN2210K519	220P 50V K B TA52	C818	181-120K	2200PF 4KV M E FMTW LEAD 4.5
C568	0CE107DF618	100UF STD 16V M FL TP5	C820	0CK2220W515	2200P 500V K B TS
C601	0CE226DF618	22UF STD 16V M FL TP5	C821	0CK47201510	4700P 1KV K B S
C604	0CE475DK618	4.7UF STD 50V 20% FL TP 5	C822	0CE226DD618	22UF STD 10V 20% FL TP 5
C605	0CQ3321N509	0.0033U 100V K POLY TP	C840	0CN1010K519	100P 50V K B TA52
C606	0CF2241L438	0.22UF D 63V 5% TP 5 M/PE NI	C854	0CE107DF618	100UF STD 16V M FL TP5
"	181-007F	ECQ-V1H224JL3,50V	C855	0CE107DD618	100UF STD 10V M FL TP5
C612	0CE477DH618	470UF STD 25V M FL TP5	C857	0CE108BF618	1000UF KME 16V M FL TP5
C621	0CQ3321N509	0.0033U 100V K POLY TP	C858	0CE108BF618	1000UF KME 16V M FL TP5
C622	0CF2241L438	0.22UF D 63V 5% TP 5 M/PE NI	C860	0CE108DF618	1000UF STD 16V M FL TP5

For Capacitor & Resistors, the characters at 2nd and 3rd digit in the P/No. means as follows;	CC, CX, CK, CN : Ceramic CQ : Polyester CE : Electrolytic	RD : Carbon Film RS : Metal Oxide Film RN : Metal Film RF : Fusible
--	---	--

LOCA. NO	PART NO	DESCRIPTION
C860	0CE108BF618	1000UF KME 16V M FL TP5
C861	0CE108DF618	1000UF STD 16V M FL TP5
C862	0CE105DK618	1UF STD 50V M FL TP5
C862	0CE335CK636	3.3UF SHL,SD 50V 20% FM5 BP(D) TP
C864	0CE108BJ618	1000UF KME 35V M FL TP5
C865	181-091Q	R 470PF 1KV 10%,-10% R/TP TP5
C867	0CE227DK618	220UF STD 50V M FL TP5
C868	0CE227DD618	220UF STD 10V M FL TP5
C871	0CE227DP61A	220UF STD 160V 20% FL TP 7.5
C872	0CE107CP618	100U SHL 160V M FL TP5
C873	0CQ1041N509	0.1U 100V K POLY TP
C874	181-091D	DEHR33A102KN2A 1000PF 1KV 10%,-10% R/TP
C874	181-091Y	R 680PF 2KV 10%,-10% R/TP TP7.5
C880	0CE106DH618	10UF STD 25V M FL TP5
C901	0CE475DR618	4.7UF STD 250V 20% FL TP 5
C902	0CQ1044R539	0.1UF TE 250V K M/PE NI TP5
C903	181-033S	2KV B 122K TP7.5
C904	0CE475DR618	4.7UF STD 250V 20% FL TP 5
C920	0CN1030F679	10000P 16V M Y TA52
C921	0CE107DF618	100UF STD 16V M FL TP5
C922	0CN1510K519	150P 50V K B TA52
C923	0CE107DJ618	100UF STD 35V M FL TP5
C924	0CE107DF618	100UF STD 16V M FL TP5
C925	0CK1030W510	0.01U 500V K B S
C926	0CE106DP618	10UF STD 160V M FL TP5
C927	0CK1010W515	100P 500V K B TS
C928	0CE107DF618	100UF STD 16V M FL TP5
C929	0CK1030W510	0.01U 500V K B S
C930	0CE106DP618	10UF STD 160V M FL TP5
CP08	0CE476DF618	47UF STD 16V M FL TP5
CP09	0CE107DD618	100UF STD 10V M FL TP5
CP10	0CE337DD618	330UF STD 10V M FL TP5
CP101	0CE106DF618	10UF STD 16V M FL TP5
CP104	0CE106DF618	10UF STD 16V M FL TP5
CP105	0CE106DF618	10UF STD 16V M FL TP5
CP106	0CE107DF618	100UF STD 16V M FL TP5
CP108	0CE106DF618	10UF STD 16V M FL TP5
CP109	0CE106DF618	10UF STD 16V M FL TP5
CP11	0CN1030F679	10000P 16V M Y TA52
CP112	0CE106DF618	10UF STD 16V M FL TP5
CP12	0CN1030F679	10000P 16V M Y TA52
CP13	0CN1030F679	10000P 16V M Y TA52
CP21	0CE476DF618	47UF STD 16V M FL TP5
CP22	0CE476DF618	47UF STD 16V M FL TP5
CP25	0CE476DF618	47UF STD 16V M FL TP5
CP26	0CE105DK618	1UF STD 50V M FL TP5
CP27	0CE105DK618	1UF STD 50V M FL TP5
CP29	181-442Z	PE,ECQ-B1H104KF3(TR)
CP30	181-442Z	PE,ECQ-B1H104KF3(TR)
CP32	0CE226DF618	22UF STD 16V M FL TP5
CP33	0CE226DF618	22UF STD 16V M FL TP5
COIL & TRANSFORMER		
J125	0LA0101K119	INDUCTOR,AXIAL LEAD 1.0UH K 2.3*3.4 TP
J134	0LA0102K139	INDUCTOR,AXIAL LEAD 10UH K 4*10.5 TP
J219	0LA0680K119	INDUCTOR,AXIAL LEAD 0.68UH K 2.3*3.4 TP

LOCA. NO	PART NO	DESCRIPTION
J225	0LA0391K119	INDUCTOR,AXIAL LEAD 3.9UH K 2.3*3.4 TP
J347	0LA0391K119	INDUCTOR,AXIAL LEAD 3.9UH K 2.3*3.4 TP
L01	0LA0102K119	INDUCTOR,AXIAL LEAD 10UH K 2.3*3.4 TP
L04	0LA0102K119	INDUCTOR,AXIAL LEAD 10UH K 2.3*3.4 TP
L05	0LA0102K139	INDUCTOR,AXIAL LEAD 10UH K 4*10.5 TP
L08	0LA0102K119	INDUCTOR,AXIAL LEAD 10UH K 2.3*3.4 TP
L101	0LA0102K139	INDUCTOR,AXIAL LEAD 10UH K 4*10.5 TP
L102	0LA0102K139	INDUCTOR,AXIAL LEAD 10UH K 4*10.5 TP
L103	0LA0102K139	INDUCTOR,AXIAL LEAD 10UH K 4*10.5 TP
L121	0LA0102K139	INDUCTOR,AXIAL LEAD 10UH K 4*10.5 TP
L210	0LA0102K119	INDUCTOR,AXIAL LEAD 10UH K 2.3*3.4 TP
L211	0LA0102K119	INDUCTOR,AXIAL LEAD 10UH K 2.3*3.4 TP
L212	0LA0102K049	INDUCTOR,AXIAL LEAD 10UH 10% TP
L213	0LA0102K119	INDUCTOR,AXIAL LEAD 10UH K 2.3*3.4 TP
L214	0LA0102K119	INDUCTOR,AXIAL LEAD 10UH K 2.3*3.4 TP
L218	0LA0102K119	INDUCTOR,AXIAL LEAD 10UH K 2.3*3.4 TP
L219	0LA0102K119	INDUCTOR,AXIAL LEAD 10UH K 2.3*3.4 TP
L241	0LA0102K119	INDUCTOR,AXIAL LEAD 10UH K 2.3*3.4 TP
L242	0LA0102K119	INDUCTOR,AXIAL LEAD 10UH K 2.3*3.4 TP
L243	0LA0472K119	INDUCTOR,AXIAL LEAD 47UH K 2.3*3.4 TP
L244	0LA0472K119	INDUCTOR,AXIAL LEAD 47UH K 2.3*3.4 TP
L245	0LA0102K139	INDUCTOR,AXIAL LEAD 10UH K 4*10.5 TP
L401	150-717K	COIL,CHOKE 1.1UH PHY TURN
L402	6140VE0001J	COIL,LINEARITY 20UH USTC0.12PHY 48.5TURN
L509	0LA0102K119	INDUCTOR,AXIAL LEAD 10UH K 2.3*3.4 TP
L510	0LA0102K119	INDUCTOR,AXIAL LEAD 10UH K 2.3*3.4 TP
L512	0LA0102K139	INDUCTOR,AXIAL LEAD 10UH K 4*10.5 TP
L663	0LA0102K119	INDUCTOR,AXIAL LEAD 10UH K 2.3*3.4 TP
L810	0LA0102K119	INDUCTOR,AXIAL LEAD 10UH K 2.3*3.4 TP
L853	150-C02F	COIL,CHOKE 82UH PHY TURN
LP01	0LA0472K119	INDUCTOR,AXIAL LEAD 47UH K 2.3*3.4 TP
LP12	0LA0102K119	INDUCTOR,AXIAL LEAD 10UH K 2.3*3.4 TP
LP13	0LA0102K119	INDUCTOR,AXIAL LEAD 10UH K 2.3*3.4 TP
LP14	0LA0102K119	INDUCTOR,AXIAL LEAD 10UH K 2.3*3.4 TP
R242	0LA0391K119	INDUCTOR,AXIAL LEAD 3.9UH K 2.3*3.4 TP
T401	151-C02F	TRANSFORMER,H-DRIVE,EI-19,BULK
T402	6174V-5003A	FBT,BSC28-N2325 29 YINYANG 6003LB+115V
T802	6170VMCB01R	TRANSFORMER,SMPS EER5345 340UH 115V,
CONNECTOR		
P01	366-932B	CONNECTOR,2.5MM 3P GIL-G LG CABLE S
P03A	366-921J	CONNECTOR,2.5MM 10P GIL-G LG CABLE .
P03B	387-A10J	CONNECTOR,10P 2.5MM 500MM H-B UL1007
P102	366-009D	CONNECTOR,2.36PAI 1P . K/M AUTO
P180	366-932B	CONNECTOR,2.5MM 3P GIL-G LG CABLE S
P201B	366-173G	CONNECTOR,2.5MM 8*2P AEPH-254 A/K R/A
P202B	366-173G	CONNECTOR,2.5MM 8*2P AEPH-254 A/K R/A
P203B	366-173E	CONNECTOR,2.5MM 6*2P AEPH-254 A/K R/A
P401	366-043K	CONNECTOR,PLUG(4P)
P402A	366-921G	CONNECTOR,2.5MM 8P GIL-G LG CABLE .
P402B	387-A08H	CONNECTOR,8P 2.5MM 450MM H-B UL1007
P601	366-932B	CONNECTOR,2.5MM 3P GIL-G LG CABLE S
P602	366-932C	CONNECTOR,2.5MM 4P GIL-G LG CABLE S
P801A	366-009D	CONNECTOR,2.36PAI 1P . K/M AUTO
P801B	366-009D	CONNECTOR,2.36PAI 1P . K/M AUTO
P802A	366-009D	CONNECTOR,2.36PAI 1P . K/M AUTO

For Capacitor & Resistors, the characters at 2nd and 3rd digit in the P/No. means as follows;	CC, CX, CK, CN : Ceramic CQ : Polyester CE : Electrolytic	RD : Carbon Film RS : Metal Oxide Film RN : Metal Film RF : Fusible
--	---	--

LOCA. NO	PART NO	DESCRIPTION
P802B	366-009D	CONNECTOR,2.36PAI 1P . K/M AUTO
P901	366-009D	CONNECTOR,2.36PAI 1P . K/M AUTO
P903	366-009D	CONNECTOR,2.36PAI 1P . K/M AUTO
P920	366-932B	CONNECTOR,2.5MM 3P GIL-G LG CABLE S
PP501	366-932B	CONNECTOR,2.5MM 3P GIL-G LG CABLE S
RESISTOR		
F851	ORP0020J809	0.02 OHM 1 W 20% TA52
F853	ORP0050H709	0.05 OHM 1/2 W 10% TA52
F854	ORP0050H709	0.05 OHM 1/2 W 10% TA52
F855	ORP0050H709	0.05 OHM 1/2 W 10% TA52
FR402	ORF0101K607	1 OHM 2 W 5.00% TA62
FR403	ORP0050H709	0.05 OHM 1/2 W 10% TA52
FR406	ORF0121K607	1.2 OHM 2 W 5.00% TA62
FR406	ORF0101K607	1 OHM 2 W 5.00% TA62
FR413	ORP0050H709	0.05 OHM 1/2 W 10% TA52
FR901	ORF0121K607	1.2 OHM 2 W 5.00% TA62
J128	ORD1002F609	10K OHM 1/6 W 5% TA52
J130	ORD1002F609	10K OHM 1/6 W 5% TA52
J137	ORD1000F609	100 OHM 1/6 W 5% TA52
J148	ORD3900F609	390 OHM 1/6 W 5% TA52
J149	ORD1000F609	100 OHM 1/6 W 5% TA52
J151	ORD1800F609	180 OHM 1/6 W 5% TA52
J163	ORD1000F609	100 OHM 1/6 W 5% TA52
J167	ORD1000F609	100 OHM 1/6 W 5% TA52
J170	ORD1000F609	100 OHM 1/6 W 5% TA52
J175	ORD1000F609	100 OHM 1/6 W 5% TA52
J192	ORD1000F609	100 OHM 1/6 W 5% TA52
J207	ORD1000F609	100 OHM 1/6 W 5% TA52
J210	ORD4702F609	47K OHM 1/6 W 5% TA52
J215	ORD1001F609	1K OHM 1/6 W 5% TA52
J216	ORD1001F609	1K OHM 1/6 W 5% TA52
J317	ORD1000F609	100 OHM 1/6 W 5% TA52
J318	ORD1000F609	100 OHM 1/6 W 5% TA52
R01	ORD1000F609	100 OHM 1/6 W 5% TA52
R02	ORD1000F609	100 OHM 1/6 W 5% TA52
R06	ORD3301F609	3.3K OHM 1/6 W 5.00% TA52
R06	ORD3001F609	3K OHM 1/6 W 5.00% TA52
R07	ORD1002F609	10K OHM 1/6 W 5% TA52
R08	ORD2001F609	2K OHM 1/6 W 5% TA52
R09	ORD2001F609	2K OHM 1/6 W 5% TA52
R10	ORD1000F609	100 OHM 1/6 W 5% TA52
R102	ORD5100F609	510 OHM 1/6 W 5.00% TA52
R103	ORD5600H609	560 OHM 1/2 W 5.00% TA52
R104	ORD5600H609	560 OHM 1/2 W 5.00% TA52
R11	ORD1000F609	100 OHM 1/6 W 5% TA52
R110	ORD1000F609	100 OHM 1/6 W 5% TA52
R111	ORD1002F609	10K OHM 1/6 W 5% TA52
R116	ORD4701F609	4.7K OHM 1/6 W 5% TA52
R119	ORD0102F609	10 OHM 1/6 W 5% TA52
R12	ORD1001F609	1K OHM 1/6 W 5% TA52
R123	ORD2201F609	2.2K OHM 1/6 W 5.00% TA52
R126	ORD3301F609	3.3K OHM 1/6 W 5.00% TA52
R126	ORD1001F609	1K OHM 1/6 W 5% TA52
R127	ORD1001F609	1K OHM 1/6 W 5% TA52
R127	ORD3301F609	3.3K OHM 1/6 W 5.00% TA52

LOCA. NO	PART NO	DESCRIPTION
R128	ORD0222F609	22 OHM 1/6 W 5.00% TA52
R129	ORD1000F609	100 OHM 1/6 W 5% TA52
R130	ORD1000F609	100 OHM 1/6 W 5% TA52
R131	ORD1000F609	100 OHM 1/6 W 5% TA52
R132	ORD4700F609	470 OHM 1/6 W 0.05 TA52
R133	ORD4700F609	470 OHM 1/6 W 0.05 TA52
R135	ORD5600H609	560 OHM 1/2 W 5.00% TA52
R136	ORD1002F609	10K OHM 1/6 W 5% TA52
R137	ORD1002F609	10K OHM 1/6 W 5% TA52
R138	ORD0102F609	10 OHM 1/6 W 5% TA52
R140	ORD0102F609	10 OHM 1/6 W 5% TA52
R18	ORD1000F609	100 OHM 1/6 W 5% TA52
R180	ORD1001F609	1K OHM 1/6 W 5% TA52
R181	ORD3002F609	30K OHM 1/6 W 5.00% TA52
R182	ORD6801F609	6.8K OHM 1/6 W 5.00% TA52
R183	ORD1003F609	100K OHM 1/6 W 5% TA52
R184	ORD1801F609	1.8K OHM 1/6 W 5.00% TA52
R185	ORD1801F609	1.8K OHM 1/6 W 5.00% TA52
R186	ORD4701F609	4.7K OHM 1/6 W 5% TA52
R187	ORD1801F609	1.8K OHM 1/6 W 5.00% TA52
R188	ORD2202F609	22K OHM 1/6 W 5% TA52
R189	ORD5602F609	56K OHM 1/6 W 5% TA52
R190	ORD5103F609	510K OHM 1/6 W 5.00% TA52
R191	ORD1000F609	100 OHM 1/6 W 5% TA52
R192	ORD4701F609	4.7K OHM 1/6 W 5% TA52
R193	ORD4701F609	4.7K OHM 1/6 W 5% TA52
R201	ORD0682F609	68 OHM 1/6 W 5.00% TA52
R202	ORD2200H609	220 OHM 1/2 W 5.00% TA52
R205	ORD3302F609	33K OHM 1/6 W 5% TA52
R206	ORD0752F609	75 OHM 1/6 W 5.00% TA52
R207	ORD0752F609	75 OHM 1/6 W 5.00% TA52
R208	ORD0752F609	75 OHM 1/6 W 5.00% TA52
R209	ORD0752F609	75 OHM 1/6 W 5.00% TA52
R210	ORD0682F609	68 OHM 1/6 W 5.00% TA52
R211	ORD1000F609	100 OHM 1/6 W 5% TA52
R212	ORD3901F609	3.9K OHM 1/6 W 5% TA52
R214	ORD0752F609	75 OHM 1/6 W 5.00% TA52
R215	ORD4700F609	470 OHM 1/6 W 0.05 TA52
R215	ORD2200F609	220 OHM 1/6 W 5.00% TA52
R216	ORD1000F609	100 OHM 1/6 W 5% TA52
R216	ORD1300F609	130 OHM 1/6 W 5.00% TA52
R218	ORD0752F609	75 OHM 1/6 W 5.00% TA52
R219	ORD0752F609	75 OHM 1/6 W 5.00% TA52
R220	ORD0752F609	75 OHM 1/6 W 5.00% TA52
R230	ORD1200H609	120 OHM 1/2 W 5.00% TA52
R231	ORD1200H609	120 OHM 1/2 W 5.00% TA52
R24	ORD1002F609	10K OHM 1/6 W 5% TA52
R301	ORD2201F609	2.2K OHM 1/6 W 5.00% TA52
R302	ORD0101H609	1 OHM 1/2 W 5.00% TA52
R305	ORN4700F409	470 OHM 1/6 W 1.00% TA52
R306	ORD1002F609	10K OHM 1/6 W 5% TA52
R307	ORD2202F609	22K OHM 1/6 W 5% TA52
R309	ORD4701F609	4.7K OHM 1/6 W 5% TA52
R310	ORD0392F609	39 OHM 1/6 W 5.00% TA52
R311	ORN0151H609	1.5 OHM 1/2 W 5.00% TA52
R312	ORN0471H609	4.7 OHM 1/2 W 5.00% TA52

For Capacitor & Resistors, the characters at 2nd and 3rd digit in the P/No. means as follows;	CC, CX, CK, CN : Ceramic	RD : Carbon Film
	CQ : Polyester	RS : Metal Oxide Film
	CE : Electrolytic	RN : Metal Film
		RF : Fusible

LOCA. NO	PART NO	DESCRIPTION	LOCA. NO	PART NO	DESCRIPTION
R313	0RS3900J607	390 OHM 1 W 5.00% TA62	R537	0RD2202F609	22K OHM 1/6 W 5% TA52
R315	0RD1000F609	100 OHM 1/6 W 5% TA52	R541	0RD2700F609	270 OHM 1/6 W 5% TA52
R316	0RD2702F609	27K OHM 1/6 W 5.00% TA52	R542	0RD2200F609	220 OHM 1/6 W 5.00% TA52
R317	0RD2001F609	2K OHM 1/6 W 5% TA52	R543	0RD2202F609	22K OHM 1/6 W 5% TA52
R319	0RN8202F409	82K OHM 1/6 W 1.00% TA52	R544	0RD0332F609	33 OHM 1/6 W 5.00% TA52
R320	0RD1001F609	1K OHM 1/6 W 5% TA52	R545	0RD1800F609	180 OHM 1/6 W 5.00% TA52
R321	0RS0561K619	5.6 OHM 2 W 5% TR	R546	0RD0472F609	47 OHM 1/6 W 5% TA52
R322	0RD1501F609	1.5K OHM 1/6 W 5% TA52	R548	0RD4300F609	430 OHM 1/6 W 5.00% TA52
R323	0RD2702F609	27K OHM 1/6 W 5.00% TA52	R549	0RD1800F609	180 OHM 1/6 W 5.00% TA52
R324	0RD4700F609	470 OHM 1/6 W 0.05 TA52	R550	0RD0472F609	47 OHM 1/6 W 5% TA52
R325	0RS2701H609	2.7K OHM 1/2 W 5.00% TA52	R552	0RD4300F609	430 OHM 1/6 W 5.00% TA52
R326	0RS1501H609	1.5K OHM 1/2 W 5.00% TA52	R553	0RD1800F609	180 OHM 1/6 W 5.00% TA52
R327	0RS1501H609	1.5K OHM 1/2 W 5.00% TA52	R554	0RD0472F609	47 OHM 1/6 W 5% TA52
R328	0RN8201F609	8.2K OHM 1/6 W 5.00% TA52	R556	0RD4300F609	430 OHM 1/6 W 5.00% TA52
R330	0RD3001F609	3K OHM 1/6 W 5.00% TA52	R557	0RD2701F609	2.7K OHM 1/6 W 5% TA52
R331	0RD2401F609	2.4K OHM 1/6 W 5.00% TA52	R558	0RD0222F609	22 OHM 1/6 W 5.00% TA52
R402	0RD1001F609	1K OHM 1/6 W 5% TA52	R559	0RD1001F609	1K OHM 1/6 W 5% TA52
R403	0RD5600H609	560 OHM 1/2 W 5.00% TA52	R560	0RD4301F609	4.3K OHM 1/6 W 5.00% TA52
R404	0RD0332H609	33 OHM 1/2 W 5.00% TA52	R570	0RD1800F609	180 OHM 1/6 W 5.00% TA52
R405	0RS1000K619	100 OHM 2 W 5% TR	R571	0RD3901F609	3.9K OHM 1/6 W 5% TA52
R408	0RS0221K607	2.2 OHM 2 W 5.00% TA62	R572	0RD0822F609	82 OHM 1/6 W 5% TA52
R409	0RS1801H609	1.8K OHM 1/2 W 5.00% TA52	R601	0RD1001F609	1K OHM 1/6 W 5% TA52
R410	0RMZVBK002D	15K OHM 5W +/-5% RSR V-TYPE	R601	0RD1001F609	1K OHM 1/6 W 5% TA52
R411	0RS5102H609	51K OHM 1/2 W 5.00% TA52	R602	0RD1002F609	10K OHM 1/6 W 5% TA52
R413	0RS2202H609	22K OHM 1/2 W 5.00% TA52	R603	0RD1001F609	1K OHM 1/6 W 5% TA52
R414	0RS1001H609	1K OHM 1/2 W 5.00% TA52	R603	0RD1001F609	1K OHM 1/6 W 5% TA52
R415	0RD1002F609	10K OHM 1/6 W 5% TA52	R604	0RD3301F609	3.3K OHM 1/6 W 5.00% TA52
R416	0RD1001F609	1K OHM 1/6 W 5% TA52	R607	0RS0681H609	6.8 OHM 1/2 W 5.00% TA52
R417	0RD8203F609	820K OHM 1/6 W 5.00% TA52	R608	0RD3301F609	3.3K OHM 1/6 W 5.00% TA52
R419	0RD7501H609	7.5K OHM 1/2 W 5.00% TA52	R609	0RD6201F609	6.2K OHM 1/6 W 5.00% TA52
R42	0RD0101F609	1 OHM 1/6 W 5.00% TA52	R610	0RD4702F609	47K OHM 1/6 W 5% TA52
R420	0RS0472K607	47 OHM 2 W 5.00% TA62	R611	0RD4702F609	47K OHM 1/6 W 5% TA52
R43	0RD3300F609	330 OHM 1/6 W 5.00% TA52	R624	0RD6201F609	6.2K OHM 1/6 W 5.00% TA52
R44	0RD4701F609	4.7K OHM 1/6 W 5% TA52	R629	0RD0912F609	91 OHM 1/6 W 5.00% TA52
R45	0RD1201F609	1.2K OHM 1/6 W 5% TA52	R662	0RD1000F609	100 OHM 1/6 W 5% TA52
R46	0RD8200F609	820 OHM 1/6 W 5.00% TA52	R663	0RD1000F609	100 OHM 1/6 W 5% TA52
R47	0RD3600F609	360 OHM 1/6 W 5.00% TA52	R664	0RD1002F609	10K OHM 1/6 W 5% TA52
R48	0RD4300F609	430 OHM 1/6 W 5.00% TA52	R680	0RD1000F609	100 OHM 1/6 W 5% TA52
R49	0RD5600F609	560 OHM 1/6 W 5% TA52	R681	0RD1000F609	100 OHM 1/6 W 5% TA52
R50	0RD1001F609	1K OHM 1/6 W 5% TA52	R80	0RD3301F609	3.3K OHM 1/6 W 5.00% TA52
R509	0RD0752F609	75 OHM 1/6 W 5.00% TA52	R801	0RKZVTA001K	0.47M OHM 1/2 W 5% TA52
R51	0RD3301F609	3.3K OHM 1/6 W 5.00% TA52	R802	180-822M	RWR 15W 1.0 OHM J PD
R512	0RD0752F609	75 OHM 1/6 W 5.00% TA52	R803	0RD0102H609	10 OHM 1/2 W 5.00% TA52
R513	0RD0752F609	75 OHM 1/6 W 5.00% TA52	R804	0RD4701F609	4.7K OHM 1/6 W 5% TA52
R515	0RD1800F609	180 OHM 1/6 W 5.00% TA52	R805	0RD1001F609	1K OHM 1/6 W 5% TA52
R517	0RD3000F609	300 OHM 1/6 W 5.00% TA52	R806	180-A01C	2 W RWR G 2W 0.12 J TA31(63)
R518	0RD0222F609	22 OHM 1/6 W 5.00% TA52	R807	0RKZVTA001C	8.2M OHM 1/2 W 5% TA52
R519	0RD1001F609	1K OHM 1/6 W 5% TA52	R808	0RD3301F609	3.3K OHM 1/6 W 5.00% TA52
R523	0RD1002F609	10K OHM 1/6 W 5% TA52	R809	0RS2702K619	27K OHM 2 W 5.00% TR
R525	0RD6801F609	6.8K OHM 1/6 W 5.00% TA52	R811	0RS2702K619	27K OHM 2 W 5.00% TR
R526	0RD2702F609	27K OHM 1/6 W 5.00% TA52	R813	0RD1002F609	10K OHM 1/6 W 5% TA52
R528	0RD6801F609	6.8K OHM 1/6 W 5.00% TA52	R821	0RD3601F609	3.6K OHM 1/6 W 5.00% TA52
R531	0RD1201F609	1.2K OHM 1/6 W 5% TA52	R822	0RD3301F609	3.3K OHM 1/6 W 5.00% TA52
R532	0RD1200F609	120 OHM 1/6 W 5.00% TA52	R830	0RP0050H709	0.05 OHM 1/2 W 10% TA52
R533	0RD2201F609	2.2K OHM 1/6 W 5.00% TA52	R831	0RP0050H709	0.05 OHM 1/2 W 10% TA52
R534	0RD1000F609	100 OHM 1/6 W 5% TA52	R832	0RP0020J809	0.02 OHM 1 W 20% TA52

For Capacitor & Resistors, the characters at 2nd and 3rd digit in the P/No. means as follows;	CC, CX, CK, CN : Ceramic CQ : Polyester CE : Electrolytic	RD : Carbon Film RS : Metal Oxide Film RN : Metal Film RF : Fusible
--	---	--

LOCA. NO	PART NO	DESCRIPTION
R833	0RP0050H709	0.05 OHM 1/2 W 10% TA52
R850	0RD0471F609	4.7 OHM 1/6 W 5% TA52
R852	0RS0102K619	10 OHM 2 W 5% TR
R858	0RD0471F609	4.7 OHM 1/6 W 5% TA52
R862	0RD5601F609	5.6K OHM 1/6 W 5% TA52
R863	0RD2001F609	2K OHM 1/6 W 5% TA52
R864	0RS0161K607	1.6 OHM 2 W 5.00% TA62
R865	0RS0161K607	1.6 OHM 2 W 5.00% TA62
R866	0RD1002H609	10K OHM 1/2 W 5.00% TA52
R867	0RD7502F609	75K OHM 1/6 W 5.00% TA52
R868	0RD1002F609	10K OHM 1/6 W 5% TA52
R869	0RD4701F609	4.7K OHM 1/6 W 5% TA52
R871	0RD2400F609	240 OHM 1/6 W 5.00% TA52
R871	0RD3000F609	300 OHM 1/6 W 5.00% TA52
R872	0RD2203H609	220K OHM 1/2 W 5.00% TA52
R873	0RD4701F609	4.7K OHM 1/6 W 5% TA52
R873	0RD4701F609	4.7K OHM 1/6 W 5% TA52
R90	0RD1000F609	100 OHM 1/6 W 5% TA52
R901	0RD2200F609	220 OHM 1/6 W 5.00% TA52
R902	0RD2200F609	220 OHM 1/6 W 5.00% TA52
R903	0RD2200F609	220 OHM 1/6 W 5.00% TA52
R904	0RD4700F609	470 OHM 1/6 W 0.05 TA52
R905	0RD7501F609	7.5K OHM 1/6 W 5.00% TA52
R906	0RD1000F609	100 OHM 1/6 W 5% TA52
R907	0RD1000F609	100 OHM 1/6 W 5% TA52
R908	0RD1000F609	100 OHM 1/6 W 5% TA52
R909	0RCZVTA002D	1/2 W 1.5K,10%,PLIKOR(HIGH SURGE)
R91	0RD5600H609	560 OHM 1/2W 5%
R910	0RCZVTA002D	1/2 W 1.5K,10%,PLIKOR(HIGH SURGE)
R911	0RCZVTA002D	1/2 W 1.5K,10%,PLIKOR(HIGH SURGE)
R912	0RD2204H609	2.2M OHM 1/2 W 5.00% TA52
R913	0RD4701F609	4.7K OHM 1/6 W 5% TA52
R921	0RD1000F609	100 OHM 1/6 W 5% TA52
R922	0RD0622F609	62 OHM 1/6 W 5.00% TA52
R923	0RS0102J607	10 OHM 1 W 5.00% TA62
R924	0RS3300J607	330 OHM 1 W 5.00% TA62
R925	0RS4300J607	430 OHM 1 W 5.00% TA62
R926	0RS6800K607	680 OHM 2 W 5.00% TA62
R94	0RD1000F609	100 OHM 1/6 W 5% TA52
R95	0RD1001F609	1K OHM 1/6 W 5% TA52
RP01	0RD2200F609	220 OHM 1/6 W 5.00% TA52
RP02	0RD2200F609	220 OHM 1/6 W 5.00% TA52
RP03	0RD1000F609	100 OHM 1/6 W 5% TA52
RP04	0RD1000F609	100 OHM 1/6 W 5% TA52
RP07	0RD2202F609	22K OHM 1/6 W 5% TA52
RP08	0RD2202F609	22K OHM 1/6 W 5% TA52
RP11	0RD3300F609	330 OHM 1/6 W 5.00% TA52
RP110	0RD1000F609	100 OHM 1/6 W 5% TA52
RP111	0RD1000F609	100 OHM 1/6 W 5% TA52
RP12	0RD0102F609	10 OHM 1/6 W 5% TA52
RP122	0RD1000F609	100 OHM 1/6 W 5% TA52
RP13	0RD0102F609	10 OHM 1/6 W 5% TA52
RP14	0RD0102F609	10 OHM 1/6 W 5% TA52
RP32	0RS0222K619	22 OHM 2 W 5% TR
RP33	0RS0222K619	22 OHM 2 W 5% TR

LOCA. NO	PART NO	DESCRIPTION
SWITCH		
SW01	140-315A	SWITCH,TACT SKHV17910B LG C&D NON 12V
SW02	140-315A	SWITCH,TACT SKHV17910B LG C&D NON 12V
SW03	140-315A	SWITCH,TACT SKHV17910B LG C&D NON 12V
SW04	140-315A	SWITCH,TACT SKHV17910B LG C&D NON 12V
SW05	140-315A	SWITCH,TACT SKHV17910B LG C&D NON 12V
SW06	140-315A	SWITCH,TACT SKHV17910B LG C&D NON 12V
SW801	6600VM2002A	SWITCH,SDKEA3 IEC 250V 8A HORIZONTAL 480G
FILTER & CRYSTAL		
FB202	125-123A	FILTER,FERRITE BFD3565R2F
FB202	125-123A	FILTER,FERRITE BFD3565R2F
FB220	125-123A	FILTER,FERRITE BFD3565R2F
FB241	125-123A	FILTER,FERRITE BFD3565R2F
FB401	125-022K	FILTER,FERRITE 1UH TAPING
FB801	125-022K	FILTER,FERRITE 1UH TAPING
FB802	125-022K	FILTER,FERRITE 1UH TAPING
FB803	125-022K	FILTER,FERRITE 1UH TAPING
FB855	125-022K	FILTER,FERRITE 1UH TAPING
L920	125-022K	FILTER,FERRITE 1UH TAPING
T801	150-F06T	FILTER,SQE3535 20MH PHY TURN
X01	6202VDB007B	RESONATOR,CRYSTAL HC49U 20.250MHZ 30PPM 13PF
X661	156-A02M	RESONATOR,CRYSTAL HC49U 18.432MHZ 30PPM 10PF
XP01	6202VDB007B	RESONATOR,CRYSTAL HC49U 20.250MHZ 30PPM 13PF
ACCESSORIES		
A1	3828VA0325F	MANUAL,OWNERS MC022A NEU LG AR/EN 077V/Z/088A/B TX
A1	3828VA0325B	MANUAL,OWNERS NEU LG EN 077V/Z/
A1	3828VA0325P	MANUAL,OWNERS MC022A SA LG EN 077V/Z/088
A1	3828VA0325N	MANUAL,OWNERS NEU LG FR/EN 077V/Z/
A2	6710V00077Z	REMOTE CONTROLLERMC022A FULL SPEC
A2	6710V00077Z	REMOTE CONTROLLER W/O PIP,W/O TXT
A2	6710V00088A	REMOTE CONTROLLER MC022A W/PIP W/O TXT
A4	450-018C	ADAPTER,RF 1.5KV 5MA
MISCELLANEOUS		
F801	0FT4001B51B	FUSE,SLOW BLOW 4000MA 250 V 5.2X20
"	0FT4001B53C	FUSE,SLOW BLOW 4000MA 250 V 5.2X20
JK201	6612VMH001A	JACK,SCART UPJ-R1-018 ULIM ELEC RGB 21
"	6612VJH011K	JACK,RCA PPJ109K
JK202	6612VJH011C	JACK,RCA PPJ109C A/V IN/OUT 6P STEREO
"	6612VJH011L	JACK,RCA PPJ109L
JK203	6613V00006A	JACK ASSY 3P+EAR(PJ6062A)
PA01	6726V0006H	REMOTE CONTROLLER RECEIVER 38KHZ
RL801	6920VB1001E	RELAY,SDT-S-105LMR OEG 5V 0.05A 250V 5A 100 OHM 1A
SK901	6620VBC003A	SOCKET,CPT PCS030A PARK ELEC 8PIN 14/360
TH801	163-058D	THERMISTOR,PTC 03-07MX JA HWA 7 OHM
TU101	6700MF0001C	TUNER,TAUD-Z240D LG MULTI FS 4SYS,2IN1
"	6700MF0001E	TUNER,TAUD-Z242D LG MULTI FS 4SYS
TU102	6700MF0001D	TUNER,TAUD-Z241P LG MULTI FS 4SYS,2 IN
VD801	164-003K	VARIATOR SVC621D-14A ILJIN 620V 0%

SCHEMATIC DIAGRAM OF MC-022A [PANG PANG +]

<Q20 CONTROL PWB ASSY>

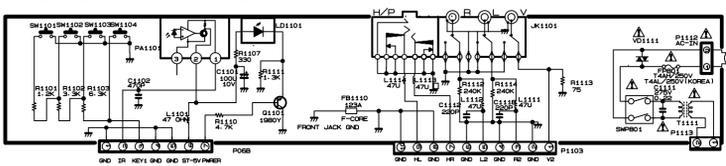

SIDE A/V BOARD

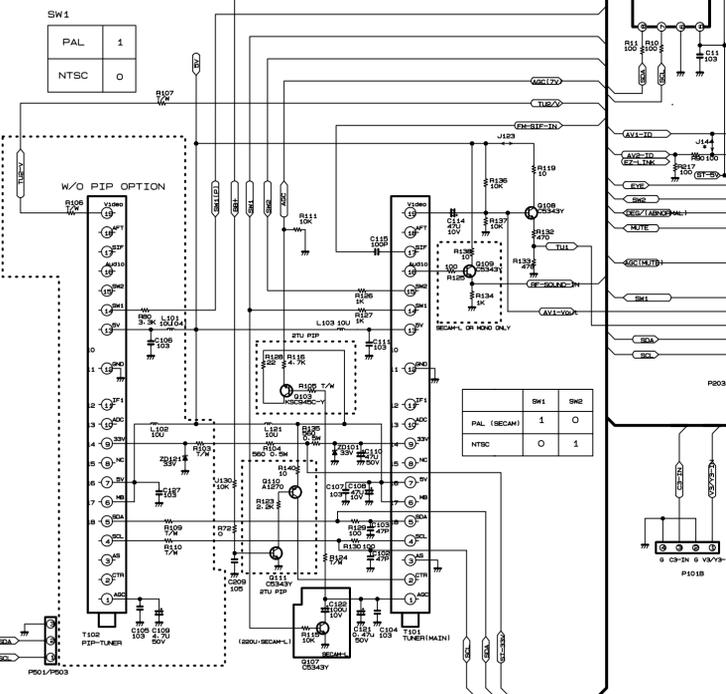
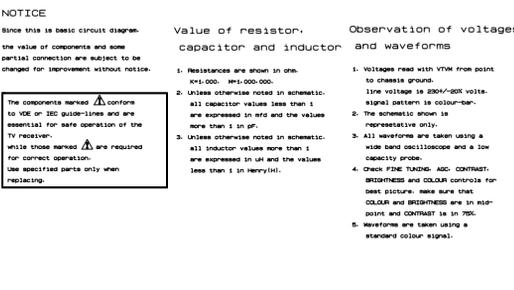
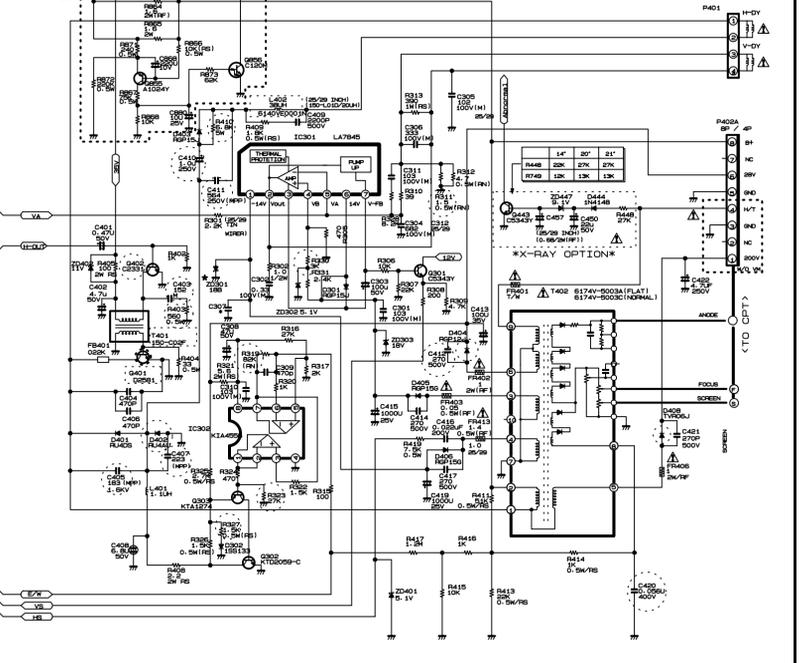
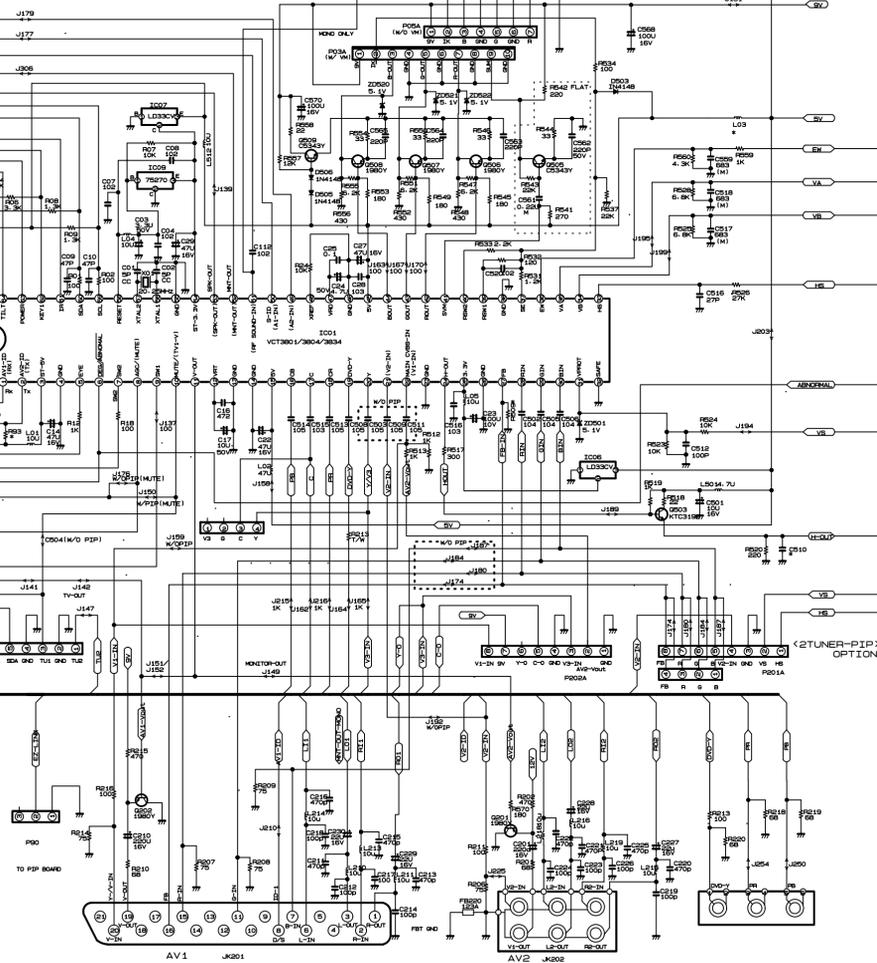
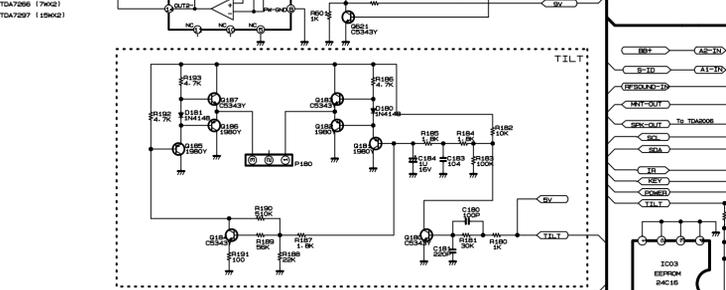
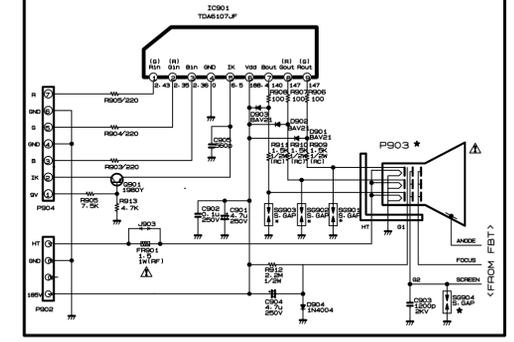
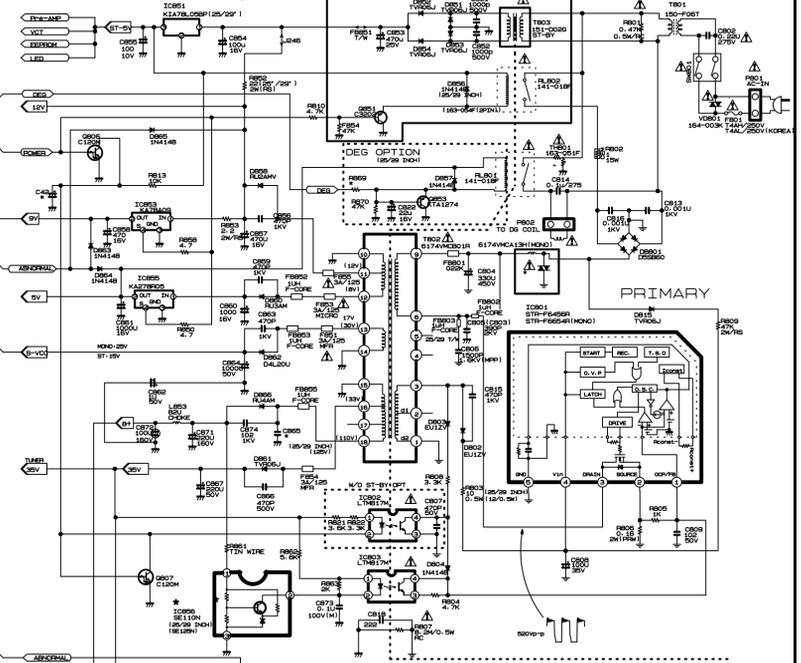
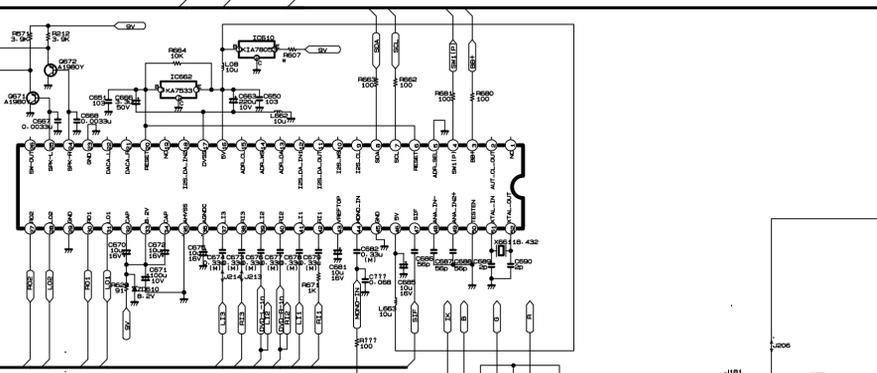
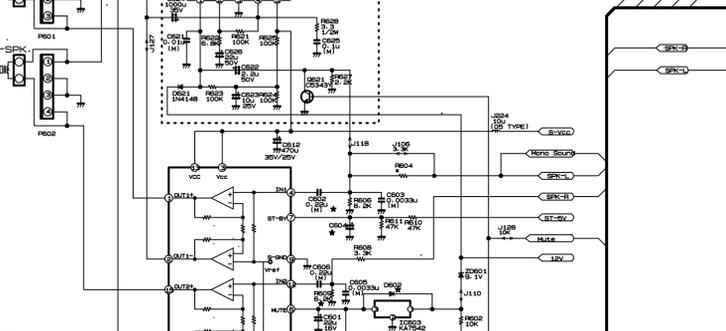
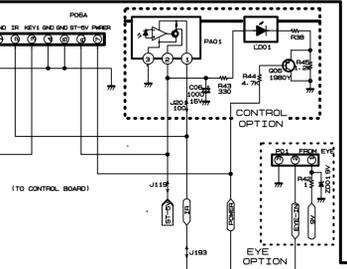
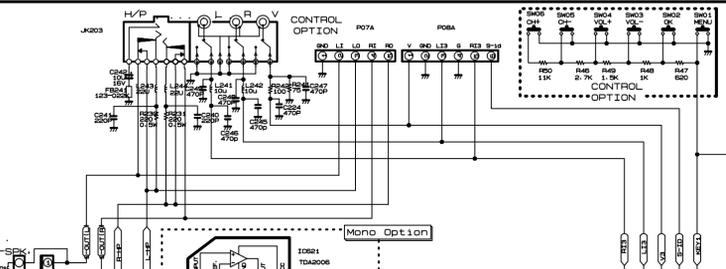
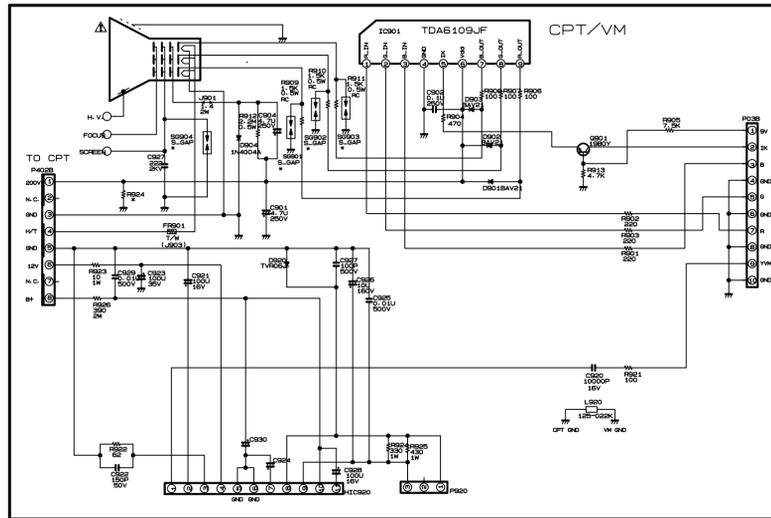
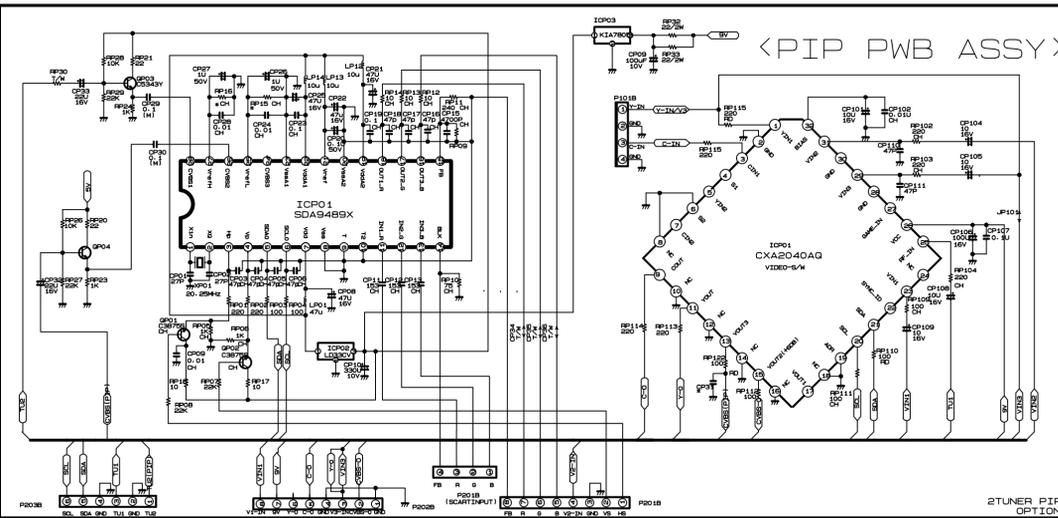
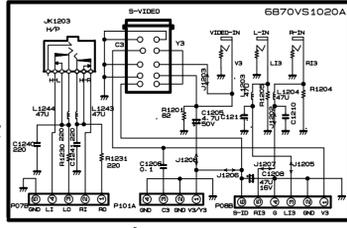

- NOTICE**
- Since this is basic circuit diagram, the value of components and some partial connection are subject to be changed for improvement without notice.
- The components marked Δ conform to VDE or IEC safety-class and are essential for safe operation of the TV receiver. While those marked Δ are required for correct operation, use the specified parts only when replacing.
- Value of resistor, capacitor and inductor**
- Resistances are shown in ohm, 100, 10K, 100K, 1M, 1000K.
 - Unless otherwise noted in schematic, all capacitor values less than 1 are expressed in pF and the values more than 1 in μ F.
 - Unless otherwise noted in schematic, all inductor values more than 1 are expressed in mH and the values less than 1 in millihenry.
- Observation of voltages and waveforms**
- Voltages read with VTVM from point to chassis ground. Line voltage is 200V/230V. Signal pattern is colour-bar, representative only.
 - All waveforms are taken using a wide band oscilloscope and a low capacity probe.
 - Check FINE TUNING, AGC, CONTRAST, BRIGHTNESS and COLOUR controls for best picture. Make sure that COLOUR and BRIGHTNESS are in stop-point and CONTRAST is in 70%.
 - Waveforms are taken using a standard colour signal.

<OPTION>

PRINTED CIRCUIT BOARD

MAIN

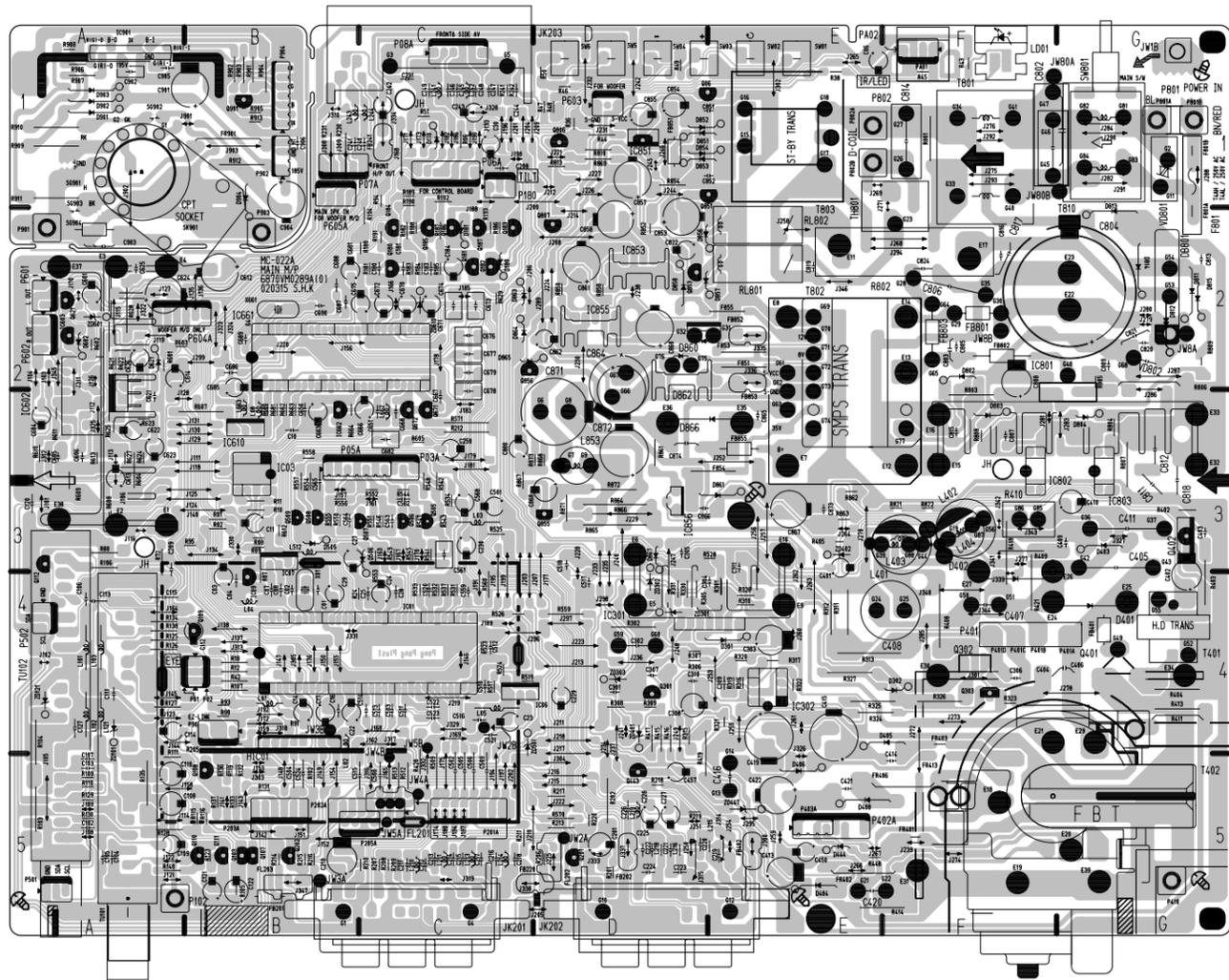

COMPONENT LOCATION GUIDE

C01.....B4	C402.....G4	C806.....F2	F854.....E3	G70.....E2	J160.....C4	J251.....D5	J345.....A3	Q110.....B5	R140.....A5	R526.....C4	R908.....A1
C02.....B4	C403.....G3	C807.....F3	F855.....D2	G71.....E2	J161.....C3	J252.....D4	J346.....E2	Q111.....B5	R141.....C2	R527.....D3	R909.....A1
C03.....B4	C404.....F4	C808.....F2	F856.....G2	G72.....E2	J162.....B4	J253.....E4	J347.....B5	Q112.....A4	R142.....C2	R528.....C4	R910.....A1
C04.....B4	C405.....G4	C809.....G2	F857.....G1	G73.....E3	J163.....C4	J254.....E5	J348.....A1	Q113.....C2	R143.....C2	R529.....C4	R911.....A2
C05.....E1	C406.....F4	C810.....G3	F858.....G1	G74.....E3	J164.....A4	J255.....E4	J349.....A2	Q114.....C2	R144.....C2	R530.....C4	R912.....B1
C07.....B4	C407.....F4	C811.....G3	F859.....D5	G75.....D2	J165.....C5	J256.....E4	J350.....B1	Q115.....C2	R145.....C2	R531.....C3	R913.....B1
C08.....B4	C408.....E4	C812.....G3	F860.....E2	G76.....D2	J166.....C5	J257.....E3	J351.....C1	Q116.....C2	R146.....C2	R532.....C4	R914.....B1
C10.....B3	C409.....G3	C813.....F1	F861.....C1	G77.....F3	J167.....C4	J258.....E2	J352.....D5	Q117.....C2	R147.....C2	R533.....C4	R915.....C4
C11.....B3	C410.....G3	C814.....F3	F862.....G4	G78.....G1	J168.....C1	J259.....E5	J353.....C1	Q118.....C2	R148.....C2	R534.....C3	R916.....A1
C14.....B4	C411.....G3	C815.....F2	F863.....D5	G79.....D2	J169.....C4	J260.....E4	J354.....F1	Q119.....C2	R149.....C2	R535.....C4	R917.....A2
C16.....B4	C412.....E5	C816.....F2	F864.....F2	G80.....G1	J170.....C4	J261.....E4	J355.....E4	Q120.....C2	R150.....C2	R536.....C4	R918.....A2
C17.....B4	C413.....E5	C817.....G3	F865.....G2	G81.....G1	J171.....C1	J262.....E4	J356.....E1	Q121.....D5	R151.....C2	R537.....C4	R919.....A2
C22.....B4	C414.....F5	C818.....G3	F866.....F3	G82.....F3	J172.....B4	J263.....E3	J357.....C1	Q122.....B5	R152.....C2	R538.....C3	R920.....A1
C23.....C4	C415.....E4	C819.....E2	F867.....D5	G83.....F3	J173.....C1	J264.....E3	J358.....G2	Q123.....D5	R153.....C2	R539.....C4	R921.....A1
C24.....C4	C416.....E5	C820.....G2	F868.....E1	G84.....F3	J174.....C5	J265.....E1	J359.....F2	Q124.....F4	R154.....C2	R540.....C3	R922.....A1
C25.....C4	C417.....E4	C821.....G2	F869.....E2	G85.....F3	J175.....C5	J266.....E5	L01.....B4	Q125.....G4	R155.....C2	R541.....C4	R923.....A1
C27.....B4	C418.....E5	C822.....D2	F870.....E3	G86.....F3	J176.....B4	J267.....E5	L02.....B5	Q126.....G3	R156.....C2	R542.....D5	R924.....D1
C29.....B4	C419.....E4	C823.....D2	F871.....E3	G87.....F3	J177.....C2	J268.....F1	L03.....B4	Q127.....D5	R157.....C2	R543.....C3	R925.....D1
C30.....C1	C420.....F5	C824.....F2	F872.....E3	G88.....F3	J178.....C2	J269.....F1	L04.....B4	Q128.....D5	R158.....C2	R544.....C3	R926.....D1
C102.....A5	C501.....C3	C854.....D1	FR402.....F5	IC06.....C4	J179.....C3	J270.....E4	L05.....C4	Q129.....C3	R159.....C2	R545.....C4	R927.....G1
C103.....A5	C502.....C5	C855.....D1	FR403.....F4	IC07.....B4	J180.....C5	J271.....F2	L06.....B3	Q130.....C3	R160.....C5	R546.....B3	R928.....F5
C104.....A5	C503.....C4	C856.....D1	FR404.....E5	IC08.....F4	J181.....C3	J272.....F5	L101.....A4	Q131.....C5	R161.....C3	R547.....C5	R929.....F1
C105.....A5	C504.....B5	C857.....D2	FR413.....F5	IC302.....E4	J182.....C1	J273.....F4	L102.....A4	Q132.....C5	R162.....C5	R548.....B3	R930.....F1
C106.....A4	C505.....C5	C858.....D2	FR901.....B1	IC602.....A3	J183.....C3	J274.....F5	L103.....A4	Q133.....C5	R163.....C5	R549.....B3	R931.....F1
C107.....A5	C506.....C5	C859.....D2	G1.....G1	IC603.....A3	J184.....C5	J275.....F1	L121.....A4	Q134.....C5	R164.....C3	R550.....B4	R932.....E1
C108.....A5	C507.....C5	C860.....D2	G2.....G1	IC604.....B3	J185.....C1	J276.....F1	L121.....C5	Q135.....C3	R165.....C3	R551.....D4	R933.....E1
C109.....A5	C508.....C5	C861.....D3	G3.....G1	IC605.....B3	J186.....C1	J277.....F3	L121.....C5	Q136.....C3	R166.....C3	R552.....D4	R934.....E1
C110.....A5	C509.....C4	C862.....D3	G4.....C5	IC606.....B3	J187.....C5	J278.....F4	L121.....C5	Q137.....C5	R167.....C5	R553.....D4	R935.....E1
C111.....A4	C510.....C4	C863.....E3	G4.....C5	IC607.....B3	J188.....C2	J279.....G2	L121.....C5	Q138.....E2	R168.....B5	R554.....C3	R936.....E1
C112.....B4	C511.....C4	C864.....E3	G5.....C1	IC608.....C1	J189.....C4	J280.....G2	L121.....C5	Q139.....D2	R169.....C5	R555.....C3	R937.....E1
C113.....A4	C512.....C4	C865.....D3	G6.....D3	IC609.....C1	J190.....C1	J281.....F3	L121.....D5	Q140.....D5	R170.....C5	R556.....C3	R938.....E1
C114.....A4	C513.....C4	C866.....D3	G7.....D3	IC610.....C3	J191.....C4	J282.....G1	L121.....D5	Q141.....D5	R171.....D5	R557.....C3	R939.....E1
C115.....A4	C514.....C4	C867.....D3	G8.....D3	IC851.....D1	J192.....B4	J283.....G3	L218.....D5	Q142.....D5	R172.....D5	R558.....C3	R940.....E1
C116.....A4	C515.....C5	C868.....D3	G9.....D3	IC852.....D2	J193.....C1	J284.....G1	L218.....D5	Q143.....D5	R173.....D5	R559.....C3	R941.....E1
C120.....A3	C516.....C4	C873.....E3	G10.....D5	IC853.....D2	J194.....C5	J285.....F4	L241.....C1	Q144.....D5	R174.....D5	R560.....C3	R942.....E1
C121.....B5	C517.....D4	C874.....D3	G11.....G1	IC856.....D3	J195.....C4	J286.....G3	L242.....C1	Q145.....D5	R175.....D5	R561.....C3	R943.....E1
C122.....B5	C518.....D3	C880.....C3	G12.....E5	IC901.....A1	J196.....C1	J287.....G2	L243.....B1	Q146.....D5	R176.....D5	R562.....C3	R944.....E1
C127.....A4	C520.....C4	C881.....B1	G13.....E5	IC902.....A1	J197.....C1	J288.....G1	L244.....C1	Q147.....D5	R177.....D5	R563.....C3	R945.....E1
C180.....C2	C62.....C4	C902.....A1	G15.....E5	J102.....A4	J198.....C1	J289.....D2	L401.....F3	Q148.....D5	R178.....D5	R564.....C3	R946.....E1
C181.....C2	C622.....C4	C903.....A2	G15.....E1	J103.....A3	J199.....C4	J290.....G1	L402.....F3	Q149.....D5	R179.....D5	R565.....C3	R947.....E1
C183.....C2	C623.....C4	C904.....B2	G16.....E1	J104.....A3	J200.....C2	J291.....G1	L403.....E3	Q150.....D5	R180.....D5	R566.....C3	R948.....E1
C184.....C2	C624.....C4	C905.....B2	G17.....E1	J105.....A3	J201.....C1	J292.....G1	L404.....F3	Q151.....D5	R181.....D5	R567.....C3	R949.....E1
C201.....D5	C559.....C4	C906.....B1	G18.....E1	J106.....A3	J202.....C5	J293.....F1	L512.....B3	Q152.....D5	R182.....D5	R568.....C3	R950.....E1
C208.....C1	C561.....C3	D110.....C1	G19.....F3	J108.....A5	J203.....C4	J294.....E2	L662.....C3	Q153.....D5	R183.....D5	R569.....C3	R951.....E1
C209.....A4	C562.....C3	D180.....C2	G21.....E5	J109.....A5	J204.....C1	J295.....E5	L663.....B3	Q154.....D5	R184.....D5	R570.....C3	R952.....E1
C210.....B5	C563.....C3	D181.....C2	G21.....E5	J110.....A5	J205.....C4	J296.....E5	L663.....D3	Q155.....D5	R185.....D5	R571.....C3	R953.....E1
C211.....C5	C564.....B3	D301.....E4	G23.....F2	J111.....A3	J206.....C4	J297.....D4	L801.....F3	Q156.....D5	R186.....D5	R572.....C3	R954.....E1
C212.....C5	C565.....B3	D302.....F4	G24.....E4	J112.....A3	J207.....C4	J298.....D4	P01.....B4	Q157.....D5	R187.....D5	R573.....C3	R955.....E1
C213.....C5	C566.....C3	D401.....G4	G25.....F4	J113.....A3	J208.....D2	J299.....A2	P02.....B4	Q158.....D5	R188.....D5	R574.....C3	R956.....E1
C214.....C5	C567.....C3	D402.....F4	G26.....F1	J114.....A5	J209.....C1	J300.....E5	P03.....B4	Q159.....D5	R189.....D5	R575.....C3	R957.....E1
C215.....C5	C568.....A3	D403.....G3	G27.....F1	J115.....A2	J210.....D5	J301.....F4	P102.....A5	Q160.....D5	R190.....D5	R576.....C3	R958.....E1
C216.....C5	C569.....A3	D404.....E5	G28.....F2	J116.....A3	J211.....D4	J302.....E1	P180.....C1	Q161.....D5	R191.....D5	R577.....C3	R959.....E1
C217.....C5	C570.....A3	D405.....E4	G29.....F2	J118.....A3	J212.....D1	J303.....B5	P410.....G5	Q162.....D5	R192.....D5	R578.....C3	R960.....E1
C218.....C5	C571.....B2	D406.....E5	G30.....F2	J119.....A2	J213.....D4	J304.....D5	P501.....A5	Q163.....D5	R193.....D5	R579.....C3	R961.....E1
C219.....E5	C613.....A3	D408.....E5	G31.....E2	J121.....A5	J214.....D4	J305.....B4	P602.....A4	Q164.....D5	R194.....D5	R580.....C3	R962.....E1
C220.....D5	C614.....A2	D444.....E5	G32.....D2	J122.....A5	J215.....D5	J308.....B1	P602.....A4	Q165.....D5	R195.....D5	R581.....C3	R963.....E1
C221.....D5	C621.....A3	D505.....B3	G33.....F2	J123.....A4	J216.....D5	J309.....B1	P602.....A4	Q166.....D5	R196.....D5	R582.....C3	R964.....E1
C222.....D5	C622.....A3	D506.....C4	G34.....F1	J124.....A3	J217.....D5	J310.....B1	P603.....D1	Q167.....D5	R197.....D5	R583.....C3	R965.....E1
C223.....D5	C623.....A3	D507.....C4	G35.....F2	J125.....A3	J218.....D5	J311.....A3	P601.....A4	Q168.....D5	R198.....D5	R584.....C3	R966.....E1
C224.....D5	C624.....A2	D521.....A2	G36.....G3	J126.....A3	J219.....C4	J312.....A3	P601.....A4	Q169.....D5	R199.....D5	R585.....C3	R967.....E1
C225.....D5	C625.....A2	D522.....F3	G37.....G3	J127.....A2	J220.....B2	J313.....B4	P603.....B2	Q170.....D5	R200.....D5	R586.....C3	R968.....E1
C226.....D5	C626.....B3	D523.....F3	G38.....F1	J128.....A3	J221.....D1	J314.....E5	P604.....B1	Q171.....D5	R201.....D5	R587.....C3	R969.....E1
C227.....D5	C627.....B3	D524.....F3	G39.....F1	J129.....A3	J222.....D2	J315.....D5	P03A.....B5	Q172.....D5	R202.....D5	R588.....C3	R970.....E1
C228.....D5	C628.....B3	D525.....F3	G40.....F2	J130.....A3	J223.....D4	J316.....C5	P05A.....B3	Q173.....D5	R203.....D5	R589.....C3	R971.....E1
C229.....D4	C629.....B3	D526.....G2	G41.....F1	J131.....A3	J224.....D2	J317.....C4	P06A.....C1	Q174.....D5	R204.....D5	R590.....C3	R972.....E1
C230.....C3	C630.....B3	D527.....G2	G42.....G4	J132.....A3	J225.....D5	J318.....B4	P07A.....C1	Q175.....D5	R205.....D5	R591.....C3	R973.....E1
C231.....C1	C631.....C3	D528.....G2	G43.....G4	J133.....A3	J226.....D2	J319.....C5	P08A.....C1	Q176.....D5	R206.....D5	R592.....C3	R974.....E1
C240.....C1	C632.....C3	D529.....G2	G44.....F1	J134.....A3	J227.....D1	J320.....C4	P201A.....C5	Q177.....D5	R207.....D5	R593.....C3	R975.....E1
C241.....B1	C633.....C2	D530.....G2	G45.....F1	J135.....B2	J228.....D4	J323.....B2	P202A.....C5	Q178.....D5	R208.....D5	R594.....C3	R976.....E1
C242.....C1	C634.....C2	D531.....G2	G46.....F1	J136.....B2	J229.....D4	J324.....B2	P203A.....B5	Q179.....D5	R209.....D5	R595.....C3	R977.....E1
C243.....C1	C635.....C2	D532.....G2	G47.....F1	J137.....B2	J230.....D4	J325.....B2	P204A.....B5	Q180.....D5	R210.....D5	R596.....C3	R978.....E1
C244.....C1	C636.....C2	D533.....G2	G48.....F1	J138.....B2	J231.....D1	J326.....E5	P401A.....G1	Q181.....D5	R211.....D5	R597.....C3	R979.....E1
C245.....C1	C637.....C2	D534.....G2	G49.....F1	J139.....B2	J232.....D1	J327.....G3	P401B.....F4	Q182.....D5	R212.....D5	R598.....C3	R980.....E1
C246.....C1	C638.....C2	D535.....G2	G50.....F4	J140.....B5	J233.....D1	J328.....G3	P401C.....F4	Q183.....D5	R213.....D5	R599.....C3	R981.....E1
C247.....C1	C639.....C2	D536.....G2	G51.....F4	J141.....B5	J234.....D1	J329.....C1	P401D.....F4	Q184.....D5	R214.....D5	R600.....C3	R982.....E1
C248.....C1	C640.....C2	D537.....G2	G52.....G2	J142.....B5	J235.....D4	J330.....B3	P402A.....E5	Q185.....D5	R215.....D5	R601.....C3	R983.....E1
C249.....C1	C641.....C2	D538.....G2	G53.....G2	J143.....C4	J236.....D4	J331.....B4	P403A.....E5	Q186.....D5	R216.....D5	R602.....C3	R984.....E1
C250.....C3	C642.....C2	D539.....G2	G54.....G4	J144.....C4	J237.....D5	J332.....C5	P404A.....A2	Q187.....D5	R217.....D5	R603.....C3	R985.....E1
C301.....D4	C681.....B2	D863.....E2	G56.....F3	J146.....B5	J238.....D2	J333.....D5	P605A.....B2	Q188.....D5	R218.....D5	R604.....C3	R986.....E1
C302.....D4	C682.....C										

SVC. SHEET : 3854VA0098A-S

Free Manuals Download Website

<http://myh66.com>

<http://usermanuals.us>

<http://www.somanuals.com>

<http://www.4manuals.cc>

<http://www.manual-lib.com>

<http://www.404manual.com>

<http://www.luxmanual.com>

<http://aubethermostatmanual.com>

Golf course search by state

<http://golfingnear.com>

Email search by domain

<http://emailbydomain.com>

Auto manuals search

<http://auto.somanuals.com>

TV manuals search

<http://tv.somanuals.com>