



LG

Life's Good

North/Latin America
Europe/Africa
Asia/Oceania

Internal Use Only

<http://aic.lgservice.com>
<http://eic.lgservice.com>
<http://biz.lgservice.com>

LED LCD TV

SERVICE MANUAL

CHASSIS : LD21A

MODEL : 19LS3500/350S/350T

19LS3500/350S/350T-ZA

CAUTION

BEFORE SERVICING THE CHASSIS,
READ THE SAFETY PRECAUTIONS IN THIS MANUAL.

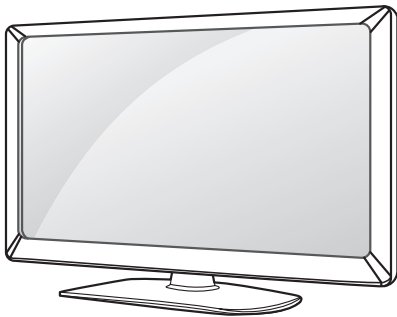

P/NO : MFL67360701 (1202-REV00)

Printed in Korea

CONTENTS

CONTENTS	2
SAFETY PRECAUTIONS	3
SERVICING PRECAUTIONS	4
SPECIFICATION	6
ADJUSTMENT INSTRUCTION	9
DISASSEMBLY	16
BLOCK DIAGRAM	17
EXPLODED VIEW	18
SCHEMATIC CIRCUIT DIAGRAM	

SAFETY PRECAUTIONS

IMPORTANT SAFETY NOTICE

Many electrical and mechanical parts in this chassis have special safety-related characteristics. These parts are identified by \triangle in the Schematic Diagram and Exploded View.

It is essential that these special safety parts should be replaced with the same components as recommended in this manual to prevent Shock, Fire, or other Hazards.

Do not modify the original design without permission of manufacturer.

General Guidance

An **isolation Transformer should always be used** during the servicing of a receiver whose chassis is not isolated from the AC power line. Use a transformer of adequate power rating as this protects the technician from accidents resulting in personal injury from electrical shocks.

It will also protect the receiver and its components from being damaged by accidental shorts of the circuitry that may be inadvertently introduced during the service operation.

If any fuse (or Fusible Resistor) in this TV receiver is blown, replace it with the specified.

When replacing a high wattage resistor (Oxide Metal Film Resistor, over 1 W), keep the resistor 10 mm away from PCB.

Keep wires away from high voltage or high temperature parts.

Before returning the receiver to the customer,

always perform an **AC leakage current check** on the exposed metallic parts of the cabinet, such as antennas, terminals, etc., to be sure the set is safe to operate without damage of electrical shock.

Leakage Current Cold Check(Antenna Cold Check)

With the instrument AC plug removed from AC source, connect an electrical jumper across the two AC plug prongs. Place the AC switch in the on position, connect one lead of ohm-meter to the AC plug prongs tied together and touch other ohm-meter lead in turn to each exposed metallic parts such as antenna terminals, phone jacks, etc.

If the exposed metallic part has a return path to the chassis, the measured resistance should be between 1 M Ω and 5.2 M Ω .

When the exposed metal has no return path to the chassis the reading must be infinite.

An other abnormality exists that must be corrected before the receiver is returned to the customer.

Leakage Current Hot Check (See below Figure)

Plug the AC cord directly into the AC outlet.

Do not use a line Isolation Transformer during this check.

Connect 1.5 K / 10 watt resistor in parallel with a 0.15 uF capacitor between a known good earth ground (Water Pipe, Conduit, etc.) and the exposed metallic parts.

Measure the AC voltage across the resistor using AC voltmeter with 1000 ohms/volt or more sensitivity.

Reverse plug the AC cord into the AC outlet and repeat AC voltage measurements for each exposed metallic part. Any voltage measured must not exceed 0.75 volt RMS which corresponds to 0.5 mA.

In case any measurement is out of the limits specified, there is possibility of shock hazard and the set must be checked and repaired before it is returned to the customer.

Leakage Current Hot Check circuit

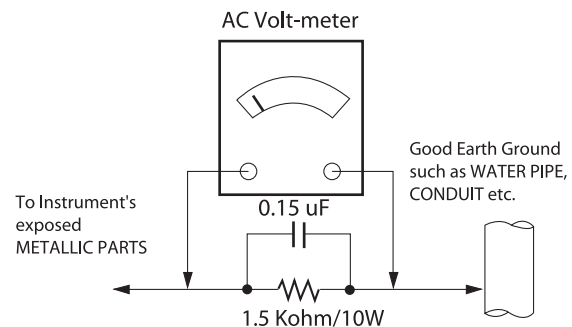

When 25A is impressed between Earth and 2nd Ground for 1 second, Resistance must be less than 0.1 Ω

*Base on Adjustment standard

SERVICING PRECAUTIONS

CAUTION: Before servicing receivers covered by this service manual and its supplements and addenda, read and follow the **SAFETY PRECAUTIONS** on page 3 of this publication.
NOTE: If unforeseen circumstances create conflict between the following servicing precautions and any of the safety precautions on page 3 of this publication, always follow the safety precautions. Remember: Safety First.

General Servicing Precautions

1. Always unplug the receiver AC power cord from the AC power source before;
 - a. Removing or reinstalling any component, circuit board module or any other receiver assembly.
 - b. Disconnecting or reconnecting any receiver electrical plug or other electrical connection.
 - c. Connecting a test substitute in parallel with an electrolytic capacitor in the receiver.
CAUTION: A wrong part substitution or incorrect polarity installation of electrolytic capacitors may result in an explosion hazard.
2. Test high voltage only by measuring it with an appropriate high voltage meter or other voltage measuring device (DVM, FETVOM, etc) equipped with a suitable high voltage probe. Do not test high voltage by "drawing an arc".
3. Do not spray chemicals on or near this receiver or any of its assemblies.
4. Unless specified otherwise in this service manual, clean electrical contacts only by applying the following mixture to the contacts with a pipe cleaner, cotton-tipped stick or comparable non-abrasive applicator; 10 % (by volume) Acetone and 90 % (by volume) isopropyl alcohol (90 % - 99 % strength)
CAUTION: This is a flammable mixture.
Unless specified otherwise in this service manual, lubrication of contacts is not required.
5. Do not defeat any plug/socket B+ voltage interlocks with which receivers covered by this service manual might be equipped.
6. Do not apply AC power to this instrument and/or any of its electrical assemblies unless all solid-state device heat sinks are correctly installed.
7. Always connect the test receiver ground lead to the receiver chassis ground before connecting the test receiver positive lead.
Always remove the test receiver ground lead last.
8. Use with this receiver only the test fixtures specified in this service manual.
CAUTION: Do not connect the test fixture ground strap to any heat sink in this receiver.

Electrostatically Sensitive (ES) Devices

Some semiconductor (solid-state) devices can be damaged easily by static electricity. Such components commonly are called Electrostatically Sensitive (ES) Devices. Examples of typical ES devices are integrated circuits and some field-effect transistors and semiconductor "chip" components. The following techniques should be used to help reduce the incidence of component damage caused by static by static electricity.

1. Immediately before handling any semiconductor component or semiconductor-equipped assembly, drain off any electrostatic charge on your body by touching a known earth ground. Alternatively, obtain and wear a commercially available discharging wrist strap device, which should be removed to prevent potential shock reasons prior to applying power to the unit under test.

2. After removing an electrical assembly equipped with ES devices, place the assembly on a conductive surface such as aluminum foil, to prevent electrostatic charge buildup or exposure of the assembly.
3. Use only a grounded-tip soldering iron to solder or unsolder ES devices.
4. Use only an anti-static type solder removal device. Some solder removal devices not classified as "anti-static" can generate electrical charges sufficient to damage ES devices.
5. Do not use freon-propelled chemicals. These can generate electrical charges sufficient to damage ES devices.
6. Do not remove a replacement ES device from its protective package until immediately before you are ready to install it. (Most replacement ES devices are packaged with leads electrically shorted together by conductive foam, aluminum foil or comparable conductive material).
7. Immediately before removing the protective material from the leads of a replacement ES device, touch the protective material to the chassis or circuit assembly into which the device will be installed.
CAUTION: Be sure no power is applied to the chassis or circuit, and observe all other safety precautions.
8. Minimize bodily motions when handling unpackaged replacement ES devices. (Otherwise harmless motion such as the brushing together of your clothes fabric or the lifting of your foot from a carpeted floor can generate static electricity sufficient to damage an ES device.)

General Soldering Guidelines

1. Use a grounded-tip, low-wattage soldering iron and appropriate tip size and shape that will maintain tip temperature within the range or 500 °F to 600 °F.
2. Use an appropriate gauge of RMA resin-core solder composed of 60 parts tin/40 parts lead.
3. Keep the soldering iron tip clean and well tinned.
4. Thoroughly clean the surfaces to be soldered. Use a small wire-bristle (0.5 inch, or 1.25 cm) brush with a metal handle. Do not use freon-propelled spray-on cleaners.
5. Use the following unsoldering technique
 - a. Allow the soldering iron tip to reach normal temperature. (500 °F to 600 °F)
 - b. Heat the component lead until the solder melts.
 - c. Quickly draw the melted solder with an anti-static, suction-type solder removal device or with solder braid.
CAUTION: Work quickly to avoid overheating the circuit board printed foil.
6. Use the following soldering technique.
 - a. Allow the soldering iron tip to reach a normal temperature (500 °F to 600 °F)
 - b. First, hold the soldering iron tip and solder the strand against the component lead until the solder melts.
 - c. Quickly move the soldering iron tip to the junction of the component lead and the printed circuit foil, and hold it there only until the solder flows onto and around both the component lead and the foil.
CAUTION: Work quickly to avoid overheating the circuit board printed foil.
 - d. Closely inspect the solder area and remove any excess or splashed solder with a small wire-bristle brush.

IC Remove/Replacement

Some chassis circuit boards have slotted holes (oblong) through which the IC leads are inserted and then bent flat against the circuit foil. When holes are the slotted type, the following technique should be used to remove and replace the IC. When working with boards using the familiar round hole, use the standard technique as outlined in paragraphs 5 and 6 above.

Removal

1. Desolder and straighten each IC lead in one operation by gently prying up on the lead with the soldering iron tip as the solder melts.
2. Draw away the melted solder with an anti-static suction-type solder removal device (or with solder braid) before removing the IC.

Replacement

1. Carefully insert the replacement IC in the circuit board.
2. Carefully bend each IC lead against the circuit foil pad and solder it.
3. Clean the soldered areas with a small wire-bristle brush. (It is not necessary to reapply acrylic coating to the areas).

"Small-Signal" Discrete Transistor Removal/Replacement

1. Remove the defective transistor by clipping its leads as close as possible to the component body.
2. Bend into a "U" shape the end of each of three leads remaining on the circuit board.
3. Bend into a "U" shape the replacement transistor leads.
4. Connect the replacement transistor leads to the corresponding leads extending from the circuit board and crimp the "U" with long nose pliers to insure metal to metal contact then solder each connection.

Power Output, Transistor Device

Removal/Replacement

1. Heat and remove all solder from around the transistor leads.
2. Remove the heat sink mounting screw (if so equipped).
3. Carefully remove the transistor from the heat sink of the circuit board.
4. Insert new transistor in the circuit board.
5. Solder each transistor lead, and clip off excess lead.
6. Replace heat sink.

Diode Removal/Replacement

1. Remove defective diode by clipping its leads as close as possible to diode body.
2. Bend the two remaining leads perpendicular y to the circuit board.
3. Observing diode polarity, wrap each lead of the new diode around the corresponding lead on the circuit board.
4. Securely crimp each connection and solder it.
5. Inspect (on the circuit board copper side) the solder joints of the two "original" leads. If they are not shiny, reheat them and if necessary, apply additional solder.

Fuse and Conventional Resistor

Removal/Replacement

1. Clip each fuse or resistor lead at top of the circuit board hollow stake.
2. Securely crimp the leads of replacement component around notch at stake top.

3. Solder the connections.

CAUTION: Maintain original spacing between the replaced component and adjacent components and the circuit board to prevent excessive component temperatures.

Circuit Board Foil Repair

Excessive heat applied to the copper foil of any printed circuit board will weaken the adhesive that bonds the foil to the circuit board causing the foil to separate from or "lift-off" the board. The following guidelines and procedures should be followed whenever this condition is encountered.

At IC Connections

To repair a defective copper pattern at IC connections use the following procedure to install a jumper wire on the copper pattern side of the circuit board. (Use this technique only on IC connections).

1. Carefully remove the damaged copper pattern with a sharp knife. (Remove only as much copper as absolutely necessary).
2. Carefully scratch away the solder resist and acrylic coating (if used) from the end of the remaining copper pattern.
3. Bend a small "U" in one end of a small gauge jumper wire and carefully crimp it around the IC pin. Solder the IC connection.
4. Route the jumper wire along the path of the out-away copper pattern and let it overlap the previously scraped end of the good copper pattern. Solder the overlapped area and clip off any excess jumper wire.

At Other Connections

Use the following technique to repair the defective copper pattern at connections other than IC Pins. This technique involves the installation of a jumper wire on the component side of the circuit board.

1. Remove the defective copper pattern with a sharp knife. Remove at least 1/4 inch of copper, to ensure that a hazardous condition will not exist if the jumper wire opens.
2. Trace along the copper pattern from both sides of the pattern break and locate the nearest component that is directly connected to the affected copper pattern.
3. Connect insulated 20-gauge jumper wire from the lead of the nearest component on one side of the pattern break to the lead of the nearest component on the other side. Carefully crimp and solder the connections.
CAUTION: Be sure the insulated jumper wire is dressed so the it does not touch components or sharp edges.

SPECIFICATION

NOTE : Specifications and others are subject to change without notice for improvement.

1. Application range

This specification is applied to the LCD TV used LD21A chassis.

2. Requirement for Test

Each part is tested as below without special appointment.

- 1) Temperature: 25 °C ± 5 °C(77 °F ± 9 °F), CST: 40 °C ± 5 °C
- 2) Relative Humidity: 65 % ± 10 %
- 3) Power Voltage
: Standard input voltage (AC 100-240 V~, 50/60 Hz)
* Standard Voltage of each products is marked by models.
- 4) Specification and performance of each parts are followed each drawing and specification by part number in accordance with BOM.
- 5) The receiver must be operated for about 5 minutes prior to the adjustment.

3. Test method

- 1) Performance: LGE TV test method followed
- 2) Demanded other specification
 - Safety : CE, IEC specification
 - EMC : CE, IEC

4. Model General Specification

No.	Item	Specification	Remarks
1	Market	EU(PAL Market-37Countries)	<p>DTV & Analog (Total 37 countries) DTV (MPEG2/4, DVB-T) :37 countries UK/Italy/Germany/France/Spain/Sweden/Finland/Netherlands/ Belgium/Luxemburg/ Greece/Denmark/Czech/Austria /Hungary/Swiss/Croatia/Turkey Norway/Slovenia/Poland/Ukraine/Portugal/Ireland/Morocco/Latvia/Estonia/Lithania/Rumania/Bulgaria/Russia/Slovakia Bosnia/Serbia/Albania/Kazakhstan/Belarus</p> <p>DTV (MPEG2/4, DVB-T2): 8 countries UK/Denmark/Sweden/Finland/Norway/Ireland/Ukraine/ Kazakhstan</p> <p>DTV (MPEG2/4, DVB-C): 37 countries UK/Italy/Germany/France/Spain/Sweden/Finland/Netherlands/ Belgium/Luxemburg/ Greece/Denmark/Czech/Austria /Hungary/Swiss/Croatia/Turkey Norway/Slovenia/Poland/Ukraine/Portugal/Ireland/Morocco/Latvia/Estonia/Lithania/Rumania/Bulgaria/Russia/Slovakia Bosnia/Serbia/Albania/Kazakhstan/Belarus</p> <p>DTV (MPEG2/4,DVB-S): 29 countries Italy/Germany/France/Spain/Netherlands/ Belgium/Luxemburg/ Greece/ Czech/Austria /Hungary/Swiss/Croatia/ Turkey/Slovenia/Poland/Portugal/ Morocco/Latvia/ Estonia/Lithania/Rumania/Bulgaria/Russia/Slovakia Bosnia/Serbia/Albania/ Belarus</p> <p>Supported satellite : 22 satellites HISPASAT 1C/1D, ATLANTIC BIRD 2, NILESAT 101/102, ATLANTIC BIRD 3, AMOS 2/3, THOR 5/6, IRIUS 4, EUTELSAT-W3A, EUROBIRD 9A, EUTELSAT-W2A, HOTBIRD 6/8/9, EUTELSAT-SESAT, ASTRA 1L/H/M/ KR, ASTRA 3A/3B, BADR 4/6, ASTRA 2D, EUROBIRD 3, EUTELSAT-W7, HELLASAT 2, EXPRESS AM1, TURK-SAT 2A/3A, INTERSAT10</p>

No.	Item	Specification	Remarks
2	Broadcasting system	1) PAL-BG 2) PAL-DK 3) PAL-I/I' 4) SECAM L/L' 5) DVB-T/T2/C/S	
3	Receiving system	Analog : Upper Heterodyne Digital : COFDM, QAM	<p>▶ DVB-T</p> <ul style="list-style-type: none"> - Guard Interval(Bitrate_Mbit/s) 1/4, 1/8, 1/16, 1/32 - Modulation : Code Rate QPSK : 1/2, 2/3, 3/4, 5/6, 7/8 16-QAM : 1/2, 2/3, 3/4, 5/6, 7/8 64-QAM : 1/2, 2/3, 3/4, 5/6, 7/8 <p>▶ DVB-T2</p> <ul style="list-style-type: none"> - Guard Interval(Bitrate_Mbit/s) 1/4, 1/8, 1/16, 1/32, 1/128, 19/128, 19/256, - Modulation : Code Rate QPSK : 1/2, 2/5, 2/3, 3/4, 5/6 16-QAM : 1/2, 2/5, 2/3, 3/4, 5/6 64-QAM : 1/2, 2/5, 2/3, 3/4, 5/6 256-QAM : 1/2, 2/5, 2/3, 3/4, 5/6 <p>▶ DVB-C</p> <ul style="list-style-type: none"> - Symbolrate : 4.0Msymbols/s to 7.2Msymbols/s - Modulation : 16QAM, 64-QAM, 128-QAM and 256-QAM <p>▶ DVB-S/S2</p> <ul style="list-style-type: none"> - symbolrate DVB-S2 (8PSK / QPSK) : 2 ~ 45Msymbol/s DVB-S (QPSK) : 2 ~ 45Msymbol/s - viterbi DVB-S mode : 1/2, 2/3, 3/4, 5/6, 7/8 DVB-S2 mode : 1/2, 2/3, 3/4, 3/5, 4/5, 5/6, 8/9, 9/10
4	Scart Jack (1EA)	PAL, SECAM	Scart 1 Jack is Full scart and support RF-OUT(analog).
5	Video Input RCA(1EA)	PAL, SECAM, NTSC	4 System : PAL, SECAM, NTSC, PAL60
6	Component Input (1EA)	Y/Cb/Cr Y/Pb/Pr	
7	RGB Input	RGB-PC	Analog(D-SUB 15PIN) Some models (LD21A,LD21C) are not supported.
8	HDMI Input (3EA)	HDMI1-DTV/DVI HDMI2-DTV HDMI3-DTV	PC(HDMI version 1.3) Support HDCP The number of Input ports is different by model.
9	Audio Input (2EA)	RGB/DVI Audio Component & AV	In case of the RGB/DVI Audio input, Some models(LD21A,LD21C) are not supported. Component & AV's audio input is used by common port.
10	SDPIF out (1EA)	SPDIF out	Some models(LD21A,LD21C) are not supported.
11	Earphone out (1EA)	Antenna, AV1, AV2, Component, RGB, HDMI1, HDMI2, HDMI3	Some models(LD21A,LD21C) are not supported.
12	USB (1EA or 2EA)	EMF, DivX HD, For SVC (download)	JPEG, MP3, DivX HD LM58, CM96: 2EA LS56, LS35, CS46, LS,34, LM34 : 1EA
13	DVB	DVB-T	CI : UK, Finland, Denmark, Norway, Sweden, Russia, Spain, Ireland, Luxemburg, Belgium, Netherland CI+ : France(Canal+), Italy(DGTvi)
		DVB-C	CI : Switzerland, Austria, Slovenia, Hungary, Bulgaria CI+ : Switzerland(UPC,Cablecom), Netherland(Ziggo), Germany(KDG,CWB), Finland(labwise)
		DVB-S	CI + : Germany(Astra HD+)
14	Ethernet (1EA)	DLNA(Wired, DMP only)	Some models (LD21A,LD21C) are not supported.

5. Video resolutions (2D)

5.1. Component Input (Y, C_B/P_B, C_R/P_R)

No.	Resolution	H-freq(kHz)	V-freq(Hz)	Pixel clock(MHz)	Proposed
1	720*576	15.625	50.00	13.5	SDTV ,DVD 576I
2	720*480	15.73	60.00	13.5135	SDTV ,DVD 480I
3	720*480	15.73	59.94	13.50	SDTV ,DVD 480I
4	720*576	31.25	50.00	27.00	SDTV 576P
5	720*480	31.50	60.00	27.027	SDTV 480P
6	720*480	31.47	59.94	27.00	SDTV 480P
7	1280*720	37.50	50.00	74.25	HDTV 720P
8	1280*720	45.00	60.00	74.25	HDTV 720P
9	1280*720	44.96	59.94	74.176	HDTV 720P
10	1920*1080	28.125	50.00	74.25	HDTV 1080I
11	1920*1080	33.75	60.00	74.25	HDTV 1080I
12	1920*1080	33.72	59.94	74.176	HDTV 1080I
13	1920*1080	56.25	50.00	148.50	HDTV 1080P
14	1920*1080	67.50	60.00	148.50	HDTV 1080P
15	1920*1080	67.432	59.94	148.352	HDTV 1080P
16	1920*1080	27.00	24.00	74.25	HDTV 1080P
17	1920*1080	26.97	23.94	74.176	HDTV 1080P
18	1920*1080	33.75	30.00	74.25	HDTV 1080P
19	1920*1080	33.71	29.97	74.176	HDTV 1080P

5.2. RGB Input (PC) – LS35/LS34/CS46 series models are not supported.

No.	Resolution	H-freq(kHz)	V-freq.(Hz)	Pixel clock(MHz)	Proposed	DDC
1	640*350	31.468	70.09	25.17	EGA	X
2	720*400	31.469	70.08	28.32	DOS	O
3	640*480	31.469	59.94	25.17	VESA(VGA)	O
4	800*600	37.879	60.31	40.00	VESA(SVGA)	O
5	1024*768	48.363	60.00	65.00	VESA(XGA)	O
6	1152*864	54.348	60.053	80.00	VESA	O
7	1360*768	47.712	60.015	85.50	VESA (WXGA)	O
8	1920*1080	67.5	60	148.5	HDTV 1080P	O

5.3. HDMI Input(PC/DTV)

No.	Resolution	H-freq(kHz)	V-freq.(Hz)	Pixel clock(MHz)	Proposed		Remark
PC(DVI)					DDC		
1	640*350	31.468	70.09	25.17	EGA	X	
2	720*400	31.469	70.08	28.32	DOS	O	
3	640*480	31.469	59.94	25.17	VESA(VGA)	O	
4	800*600	37.879	60.31	40.00	VESA(SVGA)	O	
5	1024*768	48.363	60.00	65.00	VESA(XGA)	O	
6	1152*864	54.348	60.053	80.00	VESA	O	
7	1360*768	47.712	60.015	85.50	VESA (WXGA)	O	
8	1280*1024	63.981	60.020	108.0	VESA (SXGA)	O	FHD only
9	1920*1080	67.50	60.00	148.5	HDTV 1080P	O	FHD only
DTV							
1	720*480	31.47	59.94	27.00	SDTV 480P		
2	720*480	31.50	60.00	27.027	SDTV 480P		
3	720*576	31.250	50.00	27.00	SDTV 576P		
4	1280*720	37.50	50.00	74.25	HDTV 720P		
5	1280*720	45.00	60.00	74.25	HDTV 720P		
6	1280*720	44.96	59.94	74.176	HDTV 720P		
7	1920*1080	28.125	50.00	74.25	HDTV 1080I		
8	1920*1080	33.75	60.00	74.25	HDTV 1080I		
9	1920*1080	33.72	59.94	74.176	HDTV 1080I		
10	1920*1080	56.250	50.00	148.50	HDTV 1080P		
11	1920*1080	67.50	60.00	148.50	HDTV 1080P		
12	1920*1080	67.432	59.94	148.352	HDTV 1080P		
13	1920*1080	27.00	24.00	74.25	HDTV 1080P		
14	1920*1080	26.97	23.976	74.176	HDTV 1080P		
15	1920*1080	33.75	30.00	74.25	HDTV 1080P		

ADJUSTMENT INSTRUCTION

1. Application Range

This specification sheet is applied to all of the LCD TV with LD21A chassis.

2. Designation

- (1) The adjustment is according to the order which is designated and which must be followed, according to the plan which can be changed only on agreeing.
- (2) Power adjustment : Free Voltage.
- (3) Magnetic Field Condition: Nil.
- (4) Input signal Unit: Product Specification Standard.
- (5) Reserve after operation : Above 5 Minutes (Heat Run)
Temperature : at 25 °C ± 5 °C
Relative humidity : 65 ± 10 %
Input voltage : 220 V, 60 Hz
- (6) Adjustment equipments: Color Analyzer(CA-210 or CA-110), DDC Adjustment Jig, Service remote control.
- (7) Push the "IN STOP" key - For memory initialization.

Case1 : Software version up

1. After downloading S/W by USB , TV set will reboot automatically.
2. Push "In-stop" key.
3. Push "Power on" key.
4. Function inspection
5. After function inspection, Push "In-stop" key.

Case2 : After function check at the assembly line

1. When TV set is entering on the assembly line, Push "In-stop" key at first.
2. Push "Power on" key for turning it on.
→ If you push "Power on" key, TV set will recover channel information by itself.
3. After function inspection, Push "In-stop" key.

3. Main PCB check process

- APC - After Manual-Insert, executing APC

* Boot file Download

- (1) Execute ISP program "Mstar ISP Utility" and then click "Config" tab.
- (2) Set as below, and then click "Auto Detect" and check "OK" message.
If "Error" is displayed, check connection between computer, jig, and set.
- (3) Click "Read" tab, and then load download file(XXXX.bin) by clicking "Read"

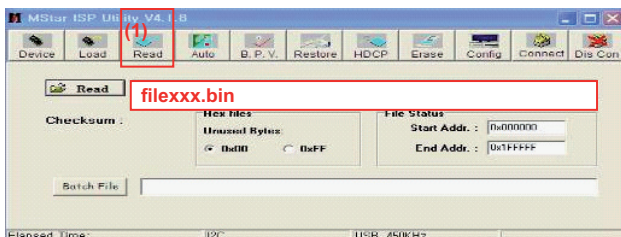

- (4) Click "Connect" tab. If "Can't" is displayed, check connection between computer, jig, and set.

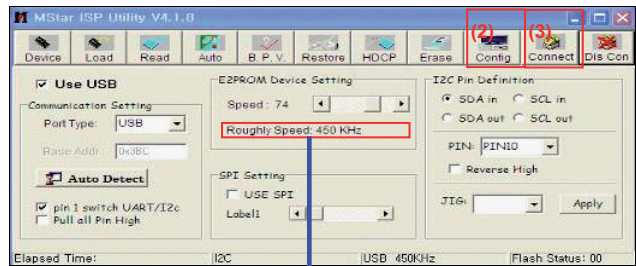

Please Check the Speed :
To use speed between
from 200KHz to 400KHz

- (5) Click "Auto" tab and set as below.
- (6) Click "Run".
- (7) After downloading, check "OK" message.

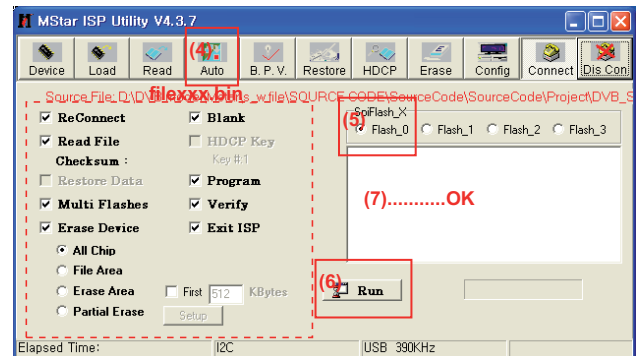

* USB DOWNLOAD

- (1) Put the USB Stick to the USB socket.
- (2) Automatically detecting update file in USB Stick.
- If your downloaded program version in USB Stick is Low, it didn't work. But your downloaded version is High, USB data is automatically detecting.
- (3) Show the message "Copying files from memory".
- (4) Updating is starting.

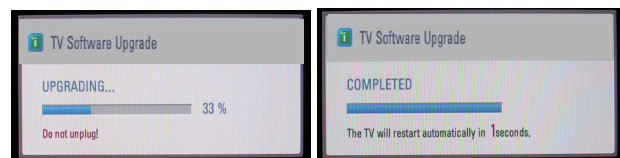

- (5) Updating Completed, The TV will restart automatically.
- (6) If your TV is turned on, check your updated version and Tool option. (explain the Tool option, next stage)

* If downloading version is more high than your TV have, TV can lost all channel data. In this case, you have to channel recover. if all channel data is cleared, you didn't have a DTV/ATV test on production line.

* After downloading, have to adjust Tool Option again.

- (1) Push "IN-START" key in service remote control.
- (2) Select "Tool Option 1" and push "OK" key.
- (3) Punch in the number. (Each model has their number)

3.1. ADC Process

(1) ADC

- Enter Service Mode by pushing "ADJ" key,
- Enter Internal ADC mode by pushing "▶" key at "7. ADC Calibration".

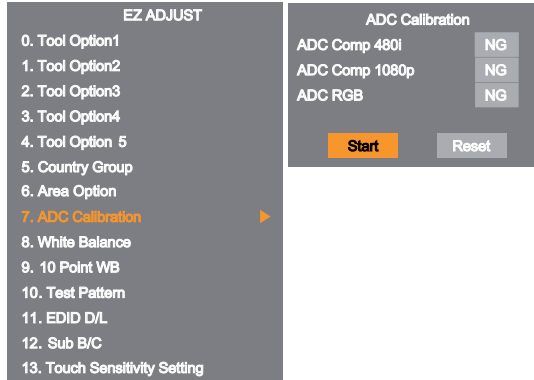

<Caution> Using "power on" key of the Adjustment remote control, power on TV.

* ADC Calibration Protocol (RS232)

NO	Item	CMD 1	CMD 2	Data 0	
Enter Adjust MODE	Adjust 'Mode In'	A	A	0 0	When transfer the 'Mode In', Carry the command.
ADC adjust	ADC Adjust	A	D	1 0	Automatically adjustment (The use of a internal pattern)

Adjust Sequence

- aa 00 00 [Enter Adjust Mode]
 - xb 00 40 [Component1 Input (480i)]
 - ad 00 10 [Adjust 480i Comp1]
 - xb 00 60 [RGB Input (1024*768)] (only LD21B)
 - ad 00 10 [Adjust 1024*768 RGB] (only LD21B)
 - aa 00 90 End Adjust mode
- * Required equipment : Adjustment remote control.

3.2. EDID Download

- After enter Service Mode by pushing "ADJ" key.
 - Enter EDID D/L menu.
 - Enter "START" by pushing "OK" key.
- <Caution> Never connect HDMI && D-sub cable when EDID downloaded.

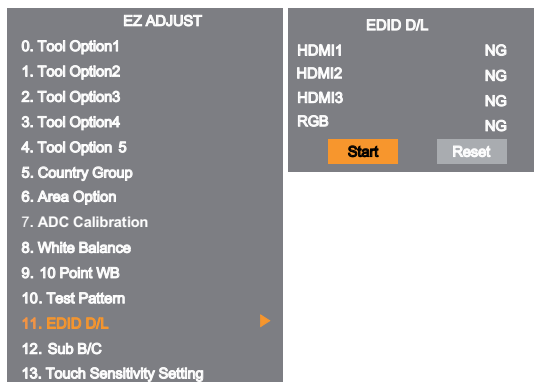

3.3. EDID data

(1) HD RGB EDID data (RGB input : only LD21B support)

	0	1	2	3	4	5	6	7	8	9	A	B	C	D	E	F
0	00	FF	FF	FF	FF	FF	FF	00	1E	6D	a			b		
10	c	01	03	68	10	09	78	0A	EE	91	A3	54	4C	99	26	
20	0F	50	54	A1	08	00	81	C0	61	40	45	40	31	40	01	01
30	01	01	01	01	01	01	1B	21	50	A0	51	00	1E	30	48	88
40	35	00	A0	5A	00	00	00	1C	01	1D	00	72	51	D0	1E	20
50	6E	28	55	00	A0	5A	00	00	00	1E	00	00	00	FD	00	3A
60	3E	1F	46	10	00	0A	20	20	20	20	20	d				
70	d														00	e

(2) HD HDMI EDID data

	0	1	2	3	4	5	6	7	8	9	A	B	C	D	E	F
0	00	FF	FF	FF	FF	FF	FF	00	1E	6D	a		b			
10	c	01	03	80	A0	5A	78	0A	EE	91	A3	54	4C	99	26	
20	0F	50	54	A1	08	00	31	40	45	40	61	40	71	40	01	01
30	01	01	01	01	01	01	66	21	50	B0	51	00	1B	30	40	70
40	36	00	40	84	63	00	00	1E	64	19	00	40	41	00	26	30
50	18	88	03	06	40	84	63	00	00	18	00	00	00	FD	00	3A
60	3E	1E	53	10	00	0A	20	20	20	20	20	d				
70	d														01	e
80	02	03	22	F1	4E	10	1F	84	13	05	14	03	02	12	20	21
90	22	15	01	26	15	07	50	09	57	07	f					
A0	80	1E	01	1D	80	18	71	1C	16	20	58	2C	25	00	A0	5A
B0	00	00	00	9E	01	1D	00	72	51	D0	1E	20	6E	28	55	00
C0	20	C2	31	00	00	1E	8C	0A	D0	8A	20	E0	2D	10	10	3E
D0	96	00	A0	5A	00	00	00	18	02	3A	80	18	71	38	2D	40
E0	58	2C	45	00	A0	5A	00	00	00	1E	00	00	00	00	00	00
F0	00	00	00	00	00	00	00	00	00	00	00	00	00	00	00	e

(3) Detail EDID Options are below

a. Product ID

MODEL NAME	HEX	EDID Table	DDC Function
HD/FHD Model	0001	01 00	Analog/Digital

b. Serial No: Controlled on production line.

c. Month, Year: Controlled on production line:

ex) Week : '01' -> '01'

Year : '2012' -> '16' fix

d. Model Name(Hex):

cf) TV set's model name in EDID data is below.

Model name	MODEL NAME(HEX)
LG TV	00 00 00 FC 00 4C 47 20 54 56 0A 20 20 20 20 20 20 (LG TV)

e. Checksum: Changeable by total EDID data.

EDID C/S data		HD	
		HDMI	RGB
Check sum (Hex)	Block 0	A4	N/A
	Block 1	5B (HDMI1)	N/A
4B (HDMI2)			

f. Vendor Specific(HDMI)

Input	Model name(HEX)
HDMI1	67030C001000
HDMI2	67030C002000
HDMI3	67030C003000

3.4 Function Check

- Check display and sound
 - Check Input and Signal items.
 - 1) TV
 - 2) AV (SCART / CVBS)
 - 3) COMPONENT (480i)
 - 4) RGB (PC : 1024 x 768 @ 60hz) (* RGB input : LD21B only support)
 - 5) HDMI
 - 6) PC Audio In (* except LD21A chassis model)
- * Display and Sound check is executed by Remote control.

<Caution>
Not to push the INSTOP key after completion if the function inspection.

4. Total Assembly line process

4.1. Adjustment Preparation

- W/B Equipment condition
CA210
: CCFL/EEFL -> CH9, Test signal: Inner pattern(80IRE)
LED -> CH14, Test signal: Inner pattern(80IRE)
- If it is executed W/B adjustment in 2~3 minutes H/run, it is adjusted by Target data

Mode	Temp	Coordinate spec	Target	
Cool	9,300 K	X=0.285 (±0.002) Y=0.293 (±0.002)	X=0.287 Y=0.296	<Test Signal> Inner pattern (204gray, 80IRE)
Medium	8,000 K	X=0.295 (±0.002) Y=0.305 (±0.002)	X=0.297 Y=0.308	
Warm	6,500 K	X=0.313 (±0.002) Y=0.329 (±0.002)	X=0.315 Y=0.332	

- Edge LED W/B Table in process of time (LGD module & 65" AUO module)

GP4	Aging time (Min)	Cool		Medium		Warm	
		X	y	x	y	x	y
		269	273	285	293	313	329
1	0-2	280	287	296	307	320	337
2	3-5	279	285	295	305	319	335
3	6-9	277	284	293	304	317	334
4	10-19	276	283	292	303	316	333
5	20-35	274	280	290	300	314	330
6	36-49	272	277	288	297	312	327
7	50-79	271	275	287	295	311	325
8	80-119	270	274	286	294	310	324
9	Over 120	269	273	285	293	309	323

- * Connecting picture of the measuring instrument (On Automatic control)
Inside PATTERN is used when W/B is controlled. Connect to auto controller or push Adjustment R/C POWER ON -> Enter the mode of White-Balance, the pattern will come out.

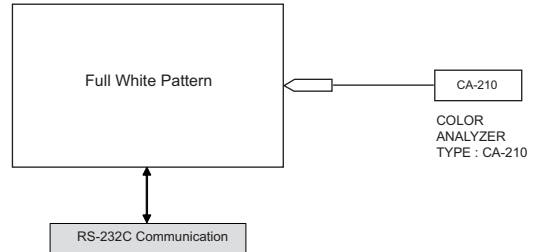

* Auto-control interface and directions

- (1) Adjust in the place where the influx of light like floodlight around is blocked. (illumination is less than 10 lux).
- (2) Adhere closely the Color analyzer(CA210) to the module less than 10 cm distance, keep it with the surface of the Module and Color analyzer's prove vertically.(80° ~ 100°).
- (3) Aging time
 - After aging start, keep the power on (no suspension of power supply) and heat-run over 5 minutes.
 - Using 'no signal' or 'POWER ONLY' or the others, check the back light on.

- Auto adjustment Map(using RS-232C to USB cable)

RS-232C COMMAND
[CMD ID DATA]
Wb 00 00 White Balance Start
Wb 00 ff White Balance End

	RS-232C COMMAND [CMD ID DATA]			MIN	CENTER (DEFAULT)			MAX
	Cool	Mid	Warm		Cool	Mid	Warm	
	R Gain	jd	Ja	jd	00	172	192	192
G Gain	jh	Jb	je	00	172	192	192	192
B Gain	ji	Jc	jf	00	192	192	172	192
R Cut					64	64	64	128
G Cut					64	64	64	128
B Cut					64	64	64	128

- <Caution>
Color Temperature : COOL, Medium, Warm.
One of R Gain/G Gain/ B Gain should be kept on 0xC0, and adjust other two lower than C0.(When R/G/B Gain are all C0, it is the FULL Dynamic Range of Module)

*** Manual W/B process using adjust Remote control.**

- After enter Service Mode by pushing "ADJ" key,
- Enter White Balance by pushing "▶" key at "8. White Balance".



- * After you finished all adjustments, Press "In-start" key and compare Tool option and Area option value with its BOM, if it is correctly same then unplug the AC cable. If it is not same, then correct it same with BOM and unplug AC cable. For correct it to the model's module from factory Jig model.
- * Push the "IN STOP" key after completing the function inspection. And Mechanical Power Switch must be set "ON".

4.2. EYE-Q function check

- (1) Turn on TV.
- (2) Press EYE key of Adjustment remote control.
- (3) Cover the Eye Q II sensor on the front of the using your hand and wait for 6 seconds.
- (4) Confirm that R/G/B value is lower than 10 of the "Raw Data (Sensor data, Back light)". If after 6 seconds, R/G/B value is not lower than 10, replace Eye Q II sensor.
- (5) Remove your hand from the Eye Q II sensor and wait for 6 seconds.
- (6) Confirm that "ok" pop up. If change is not seen, replace

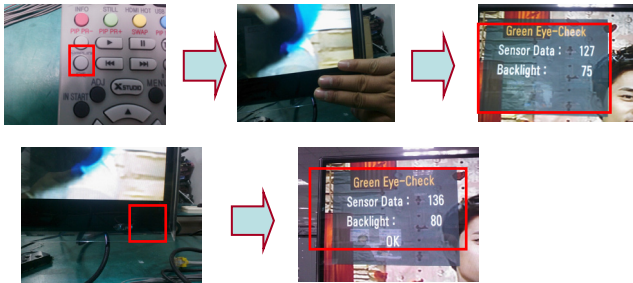

Eye Q II sensor.

4.3. Outgoing condition Configuration

- When pressing IN-STOP key by SVC remocon, Red LED are blinked alternatively. And then automatically turn off. (Must not AC power OFF during blinking)

5. HI-POT Test

5.1. HI-POT auto-check preparation

- Check the POWER cable and SIGNAL cable insertion condition

5.2. HI-POT auto-check

- (1) Pallet moves in the station. (POWER CORD / AV CORD is tightly inserted)
- (2) Connect the AV JACK Tester.
- (3) Controller (GWS103-4) on.
- (4) HI-POT test (Auto)
 - If Test is failed, Buzzer operates.
 - If Test is passed, GOOD Lamp on and move to next process automatically.

5.3. Checkpoint

- (1) Test voltage
 - Touchable Metal : 3KV / min at 100mA
 - SIGNAL : 3KV / min at 100mA
- (2) TEST time: 1 second. (case : mass production)
- (3) TEST POINT
 - Touchable Metal => LIVE & NEUTRAL : Touchable Metal.
 - SIGNAL => LIVE & NEUTRAL : SIGNAL.

6. Model name & Serial number D/L

- Press "Power on" key of service remote control. (Baud rate : 115200 bps)
- Connect USB to RS232 Signal Cable to USB Jack.
- Write Serial number.
- Must check the serial number at the Diagnostics of SET UP menu. (Refer to below.)

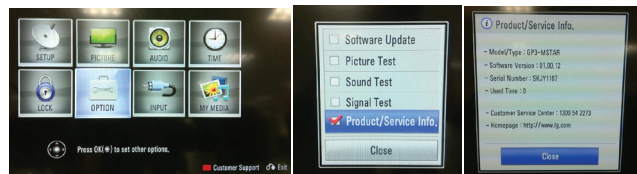

6.1. Signal Table

CMD	LENGTH	ADH	ADL	DATA_1	...	Data_n	CS	DELAY
-----	--------	-----	-----	--------	-----	--------	----	-------

CMD : A0h
 LENGTH : 85~94h (1~16 bytes)
 ADH : EEPROM Sub Address high (00~1F)
 ADL : EEPROM Sub Address low (00~FF)
 Data : Write data
 CS : CMD + LENGTH + ADH + ADL + Data_1 +...+ Data_n
 Delay : 20ms

6.2. Comand Set

Adjust mode	CMD(hex)	LENGTH(hex)	Description
EEPROM WRITE	A0h	84h+n	n-bytes Write (n = 1~16)

- * Description
 FOS Default write : <7mode data> write
 Vtotal, V_Frequency, Sync_Polarity, Htotal, Hstart, Vstart, 0, Phase
 Data write : Model Name and Serial Number write in EEPROM,.

6.3. Method & notice

- (1) Serial number D/L is using of scan equipment.
- (2) Setting of scan equipment operated by Manufacturing Technology Group.
- (3) Serial number D/L must be conformed when it is produced in production line, because serial number D/L is mandatory by D-book 4.0.

* Manual Download(Model Name and Serial Number)
 If the TV set is downloaded by OTA or Service man, sometimes model name or serial number is initialized.(Not always)
 There is impossible to download by bar code scan, so It need Manual download.

- 1) Press the "Instart" key of Adjustment remote control.
- 2) Go to the menu "6.Model Number D/L" like below photo.
- 3) Input the Factory model name or Serial number like photo.

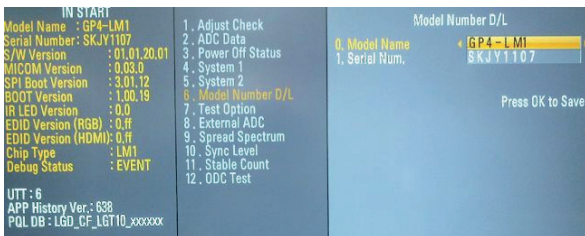

- 4) Check the model name Instart menu. → Factory name displayed. (ex 32LV3400-ZG)
- 5) Check the Diagnostics.(DTV country only) → Buyer model displayed.(ex 32LV3400-ZG)

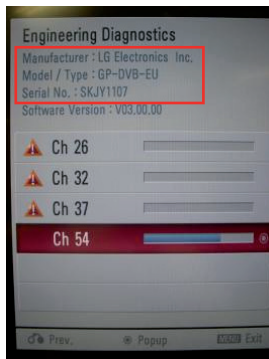

7. MAC Address & CI+ key download

7.1 MAC Address

7.1.1 Equipment & Condition

- Play file : Serial.exe
- MAC Address edit
- Input Start / End MAC address

7.1.2 Download method

- (1) Communication Prot connection

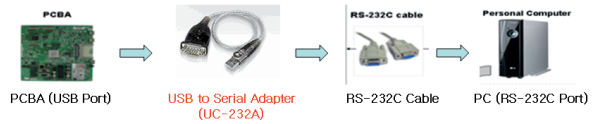

Connection : PCBA (USB Port) → USB to Serial Adapter (UC-232A) → RS-232C cable → PC(RS-232C port)

* Caution : LJ21* chassis support only UC-232A driver. (only use this one.)

- (2) MAC Address & CI+ Key Download

- Set CI+ Key path Directory at Start Mac & CI+ Download Programme
- Com 1,2,3,4 and 115200(Baudrate)

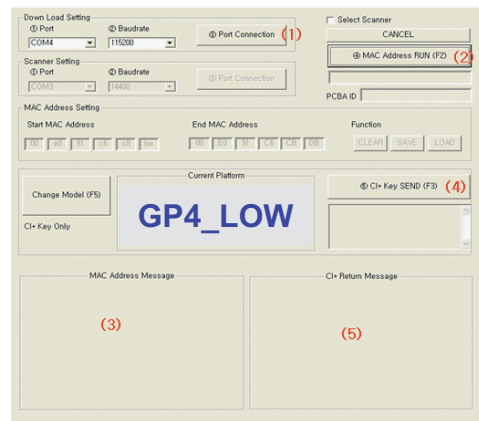

- Port connection button click(1)
- Push the (2) MAC Address write.
- At success Download, check the OK (3)
- Start CI+ Key Download, Push the (4)
- Check the OK or NG

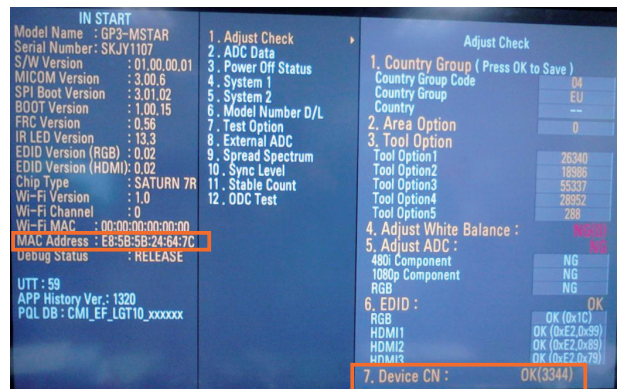

7.2 LAN Inspection

7.2.1. Equipment & Condition

- Each other connection to LAN Port of IP Hub and Jig

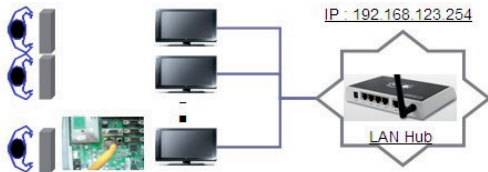

7.2.1. LAN inspection solution

- LAN Port connection with PCB
 - Network setting at MENU Mode of TV
 - Setting automatic IP
 - Setting state confirmation
- > If automatic setting is finished, you confirm IP and MAC Address.

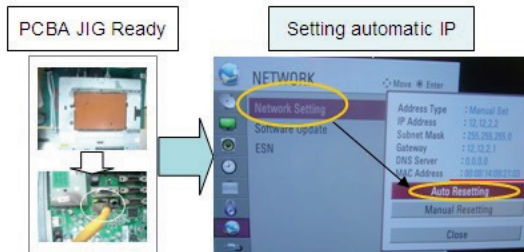

7.3. LAN PORT INSPECTION(PING TEST)

Connect SET -> LAN port == PC -> LAN Port



7.3.1. Equipment setting

- Play the LAN Port Test PROGRAM.
- Input IP set up for an inspection to Test Program.
*IP Number : 12.12.2.2

7.3.2. LAN PORT inspection (PING TEST)

- Play the LAN Port Test Program.
- Connect each other LAN Port Jack.
- Play Test (F9) button and confirm OK Message.
- Remove LAN cable.

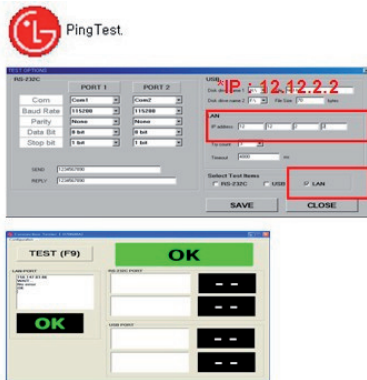

DISASSEMBLY

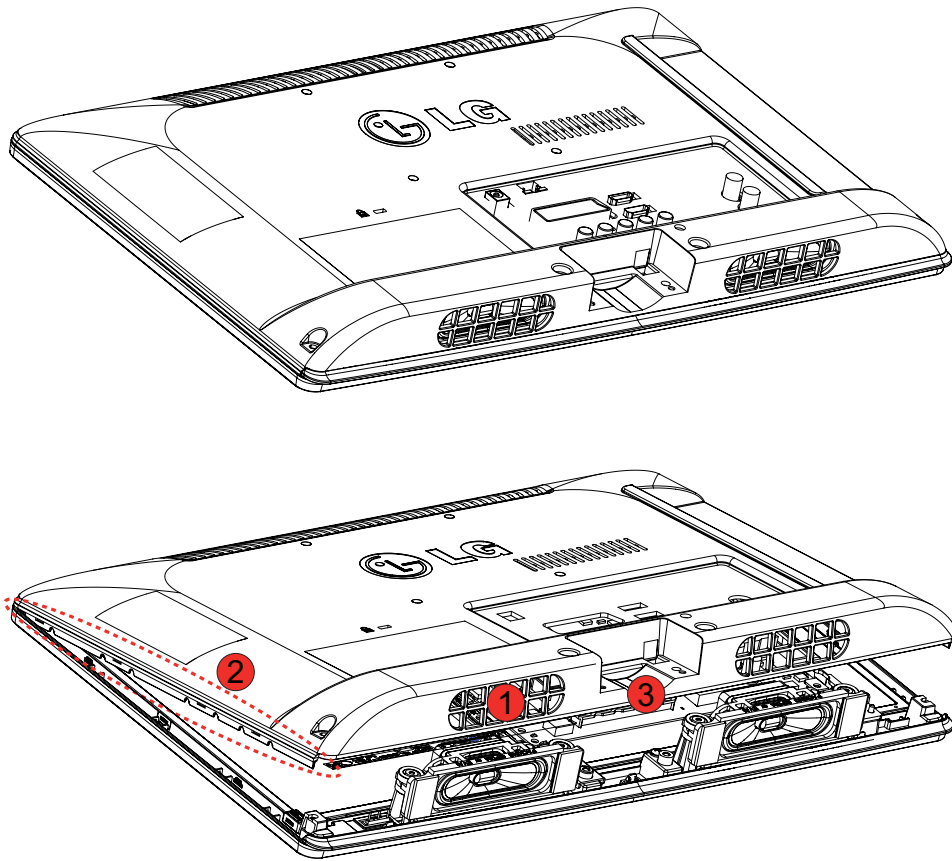

[Caution]

Please unlock latches from Bottom Side, for separating Back Cover from CABINET

[Method]

Firstly, Grab left side of Speaker Vent Hole(①) and then unlock left side latches(②) slowly.
Secondly, Grab center(③) of Back Cover and then separate Back Cover slowly.

BLOCK DIAGRAM

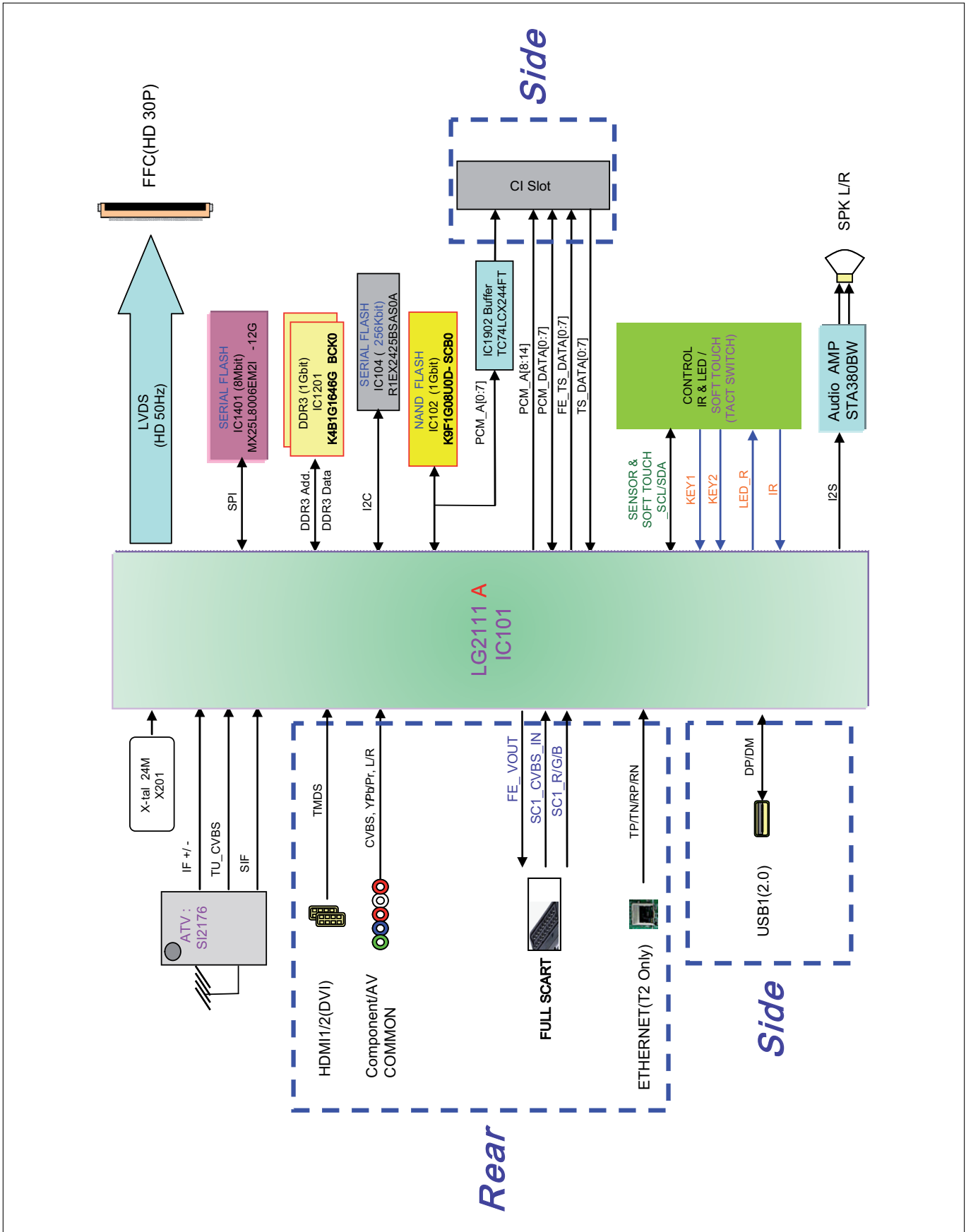

EXPLODED VIEW

IMPORTANT SAFETY NOTICE

Many electrical and mechanical parts in this chassis have special safety-related characteristics. These parts are identified by Δ in the Schematic Diagram and EXPLODED VIEW. It is essential that these special safety parts should be replaced with the same components as recommended in this manual to prevent X-RADIATION, Shock, Fire, or other Hazards. Do not modify the original design without permission of manufacturer.

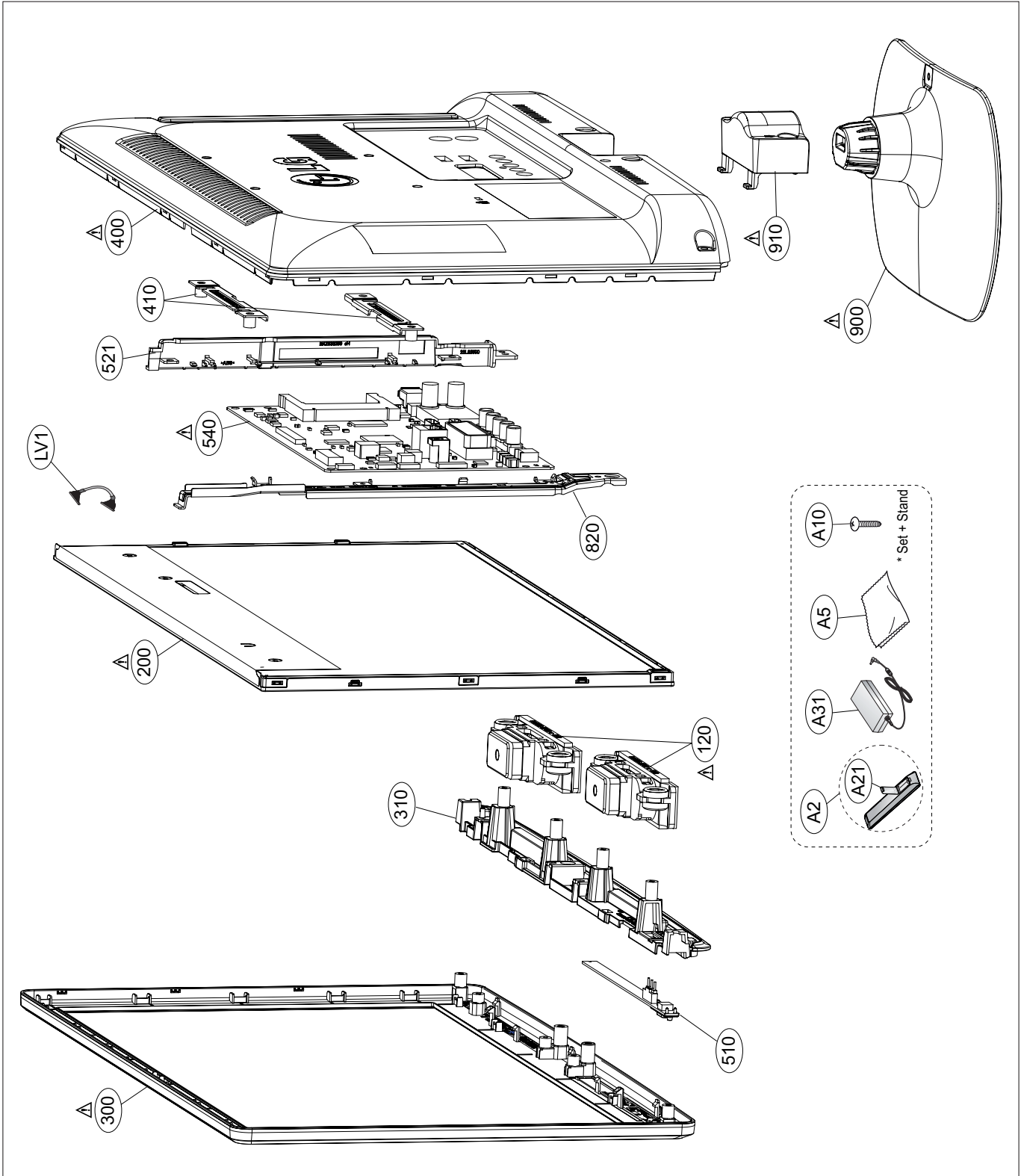

Contents of LCD TV Standard Repair Process

No.	Error symptom (High category)	Error symptom (Mid category)	Page	Remarks
1	A. Video error	No video/Normal audio	1	
2		No video/No audio	2	
3		Tuning fail, Picture broken/ Freezing	3, 4	
4		Color error	5	
5		Vertical/Horizontal bar, residual image, light spot, external device color error	6	
6	B. Power error	No power	7	
7		Off when on, off while viewing, power auto on/off	8	
8	C. Audio error	No audio/Normal video	9	
9		Wrecked audio/discontinuation/noise	10	
10	D. Function error	Remote control & Local switch checking	11	
11		External device recognition error	12	
12	E. Noise	Circuit noise, mechanical noise	13	
13	F. Exterior error	Exterior defect	14	

First of all, Check whether there is SVC Bulletin in GCSC System for these model.

Contents of LCD TV Standard Repair Process Detail Technical Manual

No.	Error symptom	Content	Page	Remarks
1	A. Video error_ No video/Normal audio	Check LCD back light with naked eye	A1	
2		LED driver B+ 24V measuring method	A2	
3		Check White Balance value	A3	
4		Power Board voltage measuring method	A4	
6	A. Video error_ No video/Video lag/stop	TUNER input signal strength checking method	A5	
7		LCD-TV Version checking method	A6	
9	A. Video error_Color error	LCD TV connection diagram	A7	
10		Check Link Cable (LVDS) reconnection condition	A8 A9	
11		Adjustment Test pattern – ADJ Key	A10	
12	A. Video error_Vertical/Horizontal bar, residual image, light spot	LCD TV connection diagram	A8	
13		Check Link Cable (LVDS) reconnection condition	A8 A9	
14		Adjustment Test pattern – ADJ Key	A10	
15	<Appendix> Defected Type caused by T-Con/ Inverter/ Module	Exchange T-Con Board (1)	A-1/5	
16		Exchange T-Con Board (2)	A-2/5	
17		Exchange LED driver Board (PSU)	A-3/5	55" : driver board Other : PSU
18		Exchange Module itself (1)	A-4/5	
19		Exchange Module itself (2)	A-5/5	

Continue to the next page

LCD TV	Error symptom	A. Video error	Established date	2012. 01 .14	
		No video/ Normal audio	Revised date		1/14

**First of all, Check whether all of cables between board is inserted properly or not.
(Main B/D ↔ Power B/D, LVDS Cable, Speaker Cable, IR B/D Cable,,)**

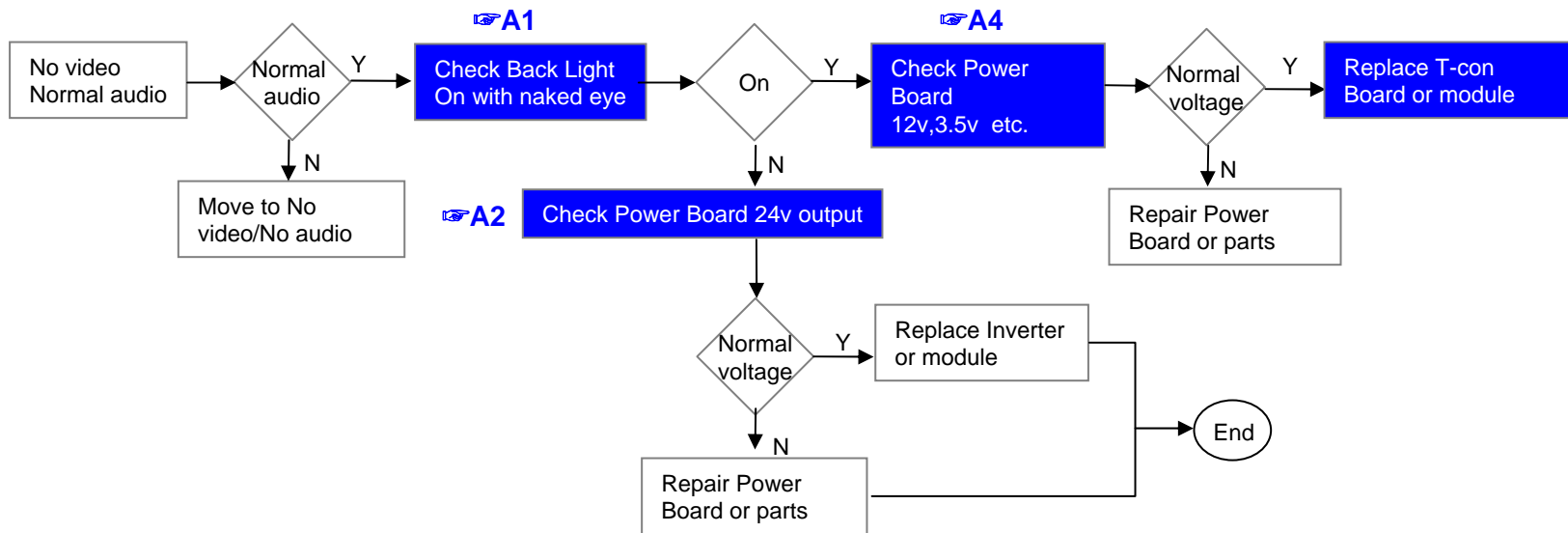

※Precaution A6 & A3

Always check & record S/W Version and White Balance value before replacing the Main Board

Replace Main Board

Re-enter White Balance value

LCD TV	Error symptom	A. Video error	Established date	2012 . 01	
		No video/ No audio	Revised date	.14	2/14

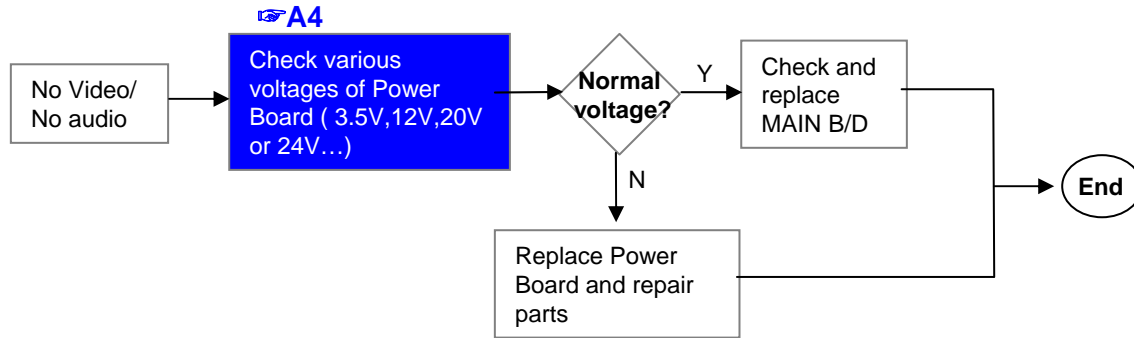

LCD TV	Error symptom	A. Video error	Established date	2012. 01 .14	
		Picture broken/ Freezing	Revised date		3/14

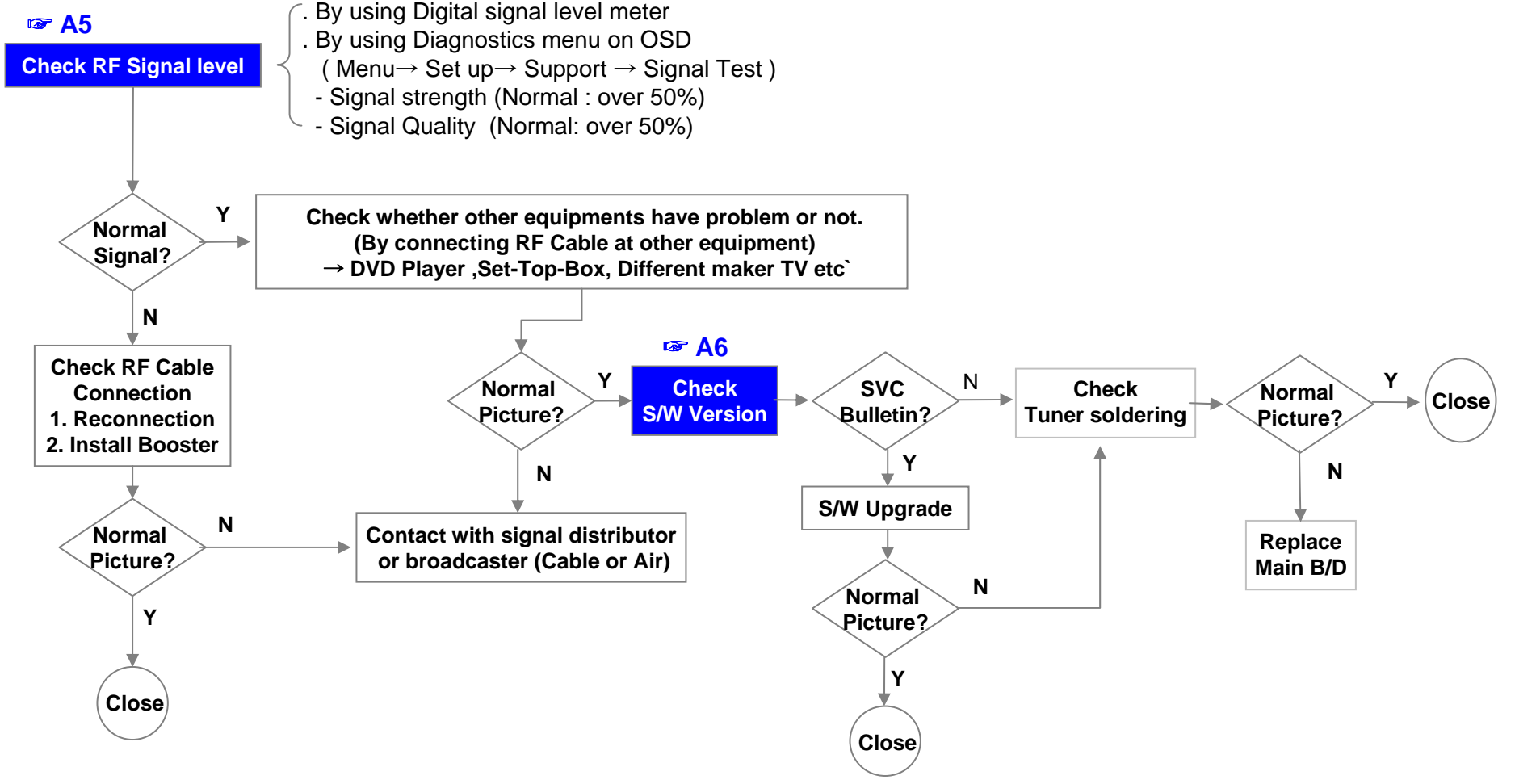

LCD TV	Error symptom	A. Video error	Established date	2012. 01 .14	
		Tuning fail, Picture broken/ Freezing	Revised date		4/14

A5

Check RF Signal level

Check RF signal cable (DVB satellite signal or not)
 Check whether other equipments have problem or not.
 (By connecting RF Cable at other equipment)
 → Set-Top-Box, Different maker TV etc

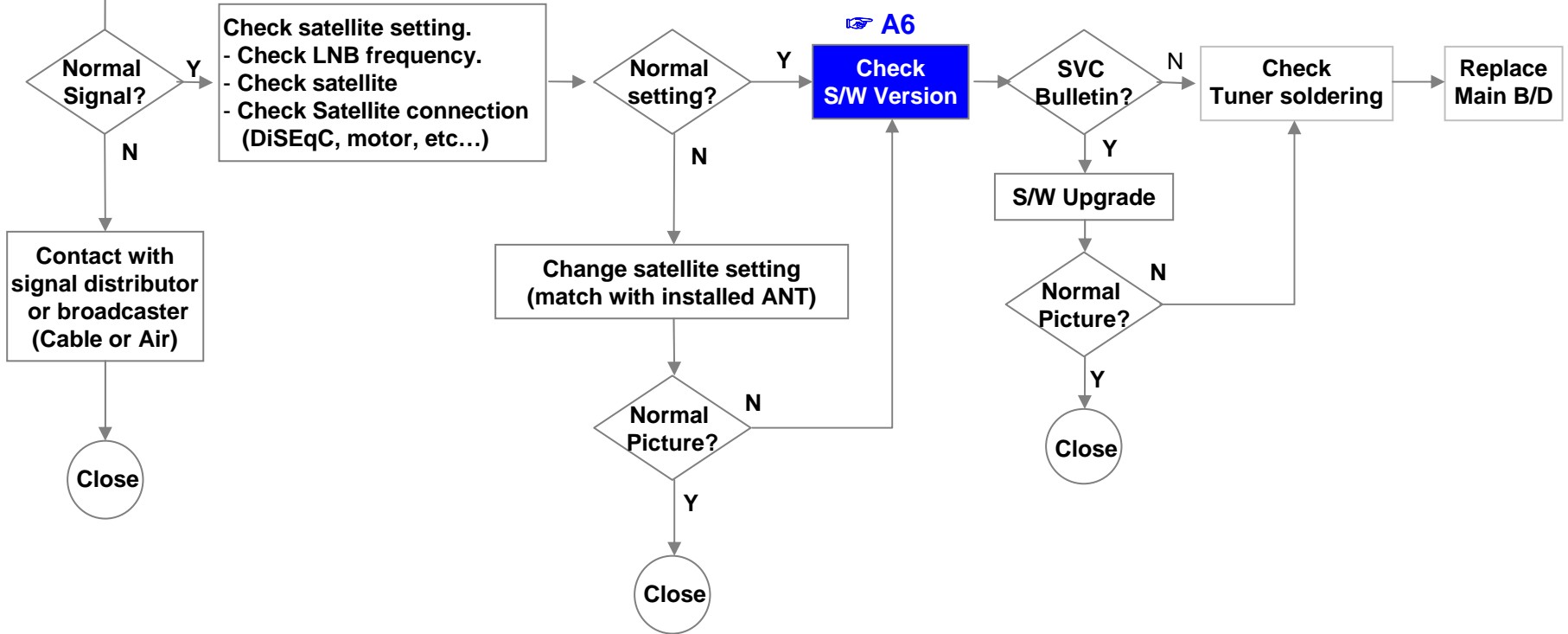

LCD TV	Error symptom	A. Video error	Established date	2012. 01 .14	
		Color error	Revised date		5/14

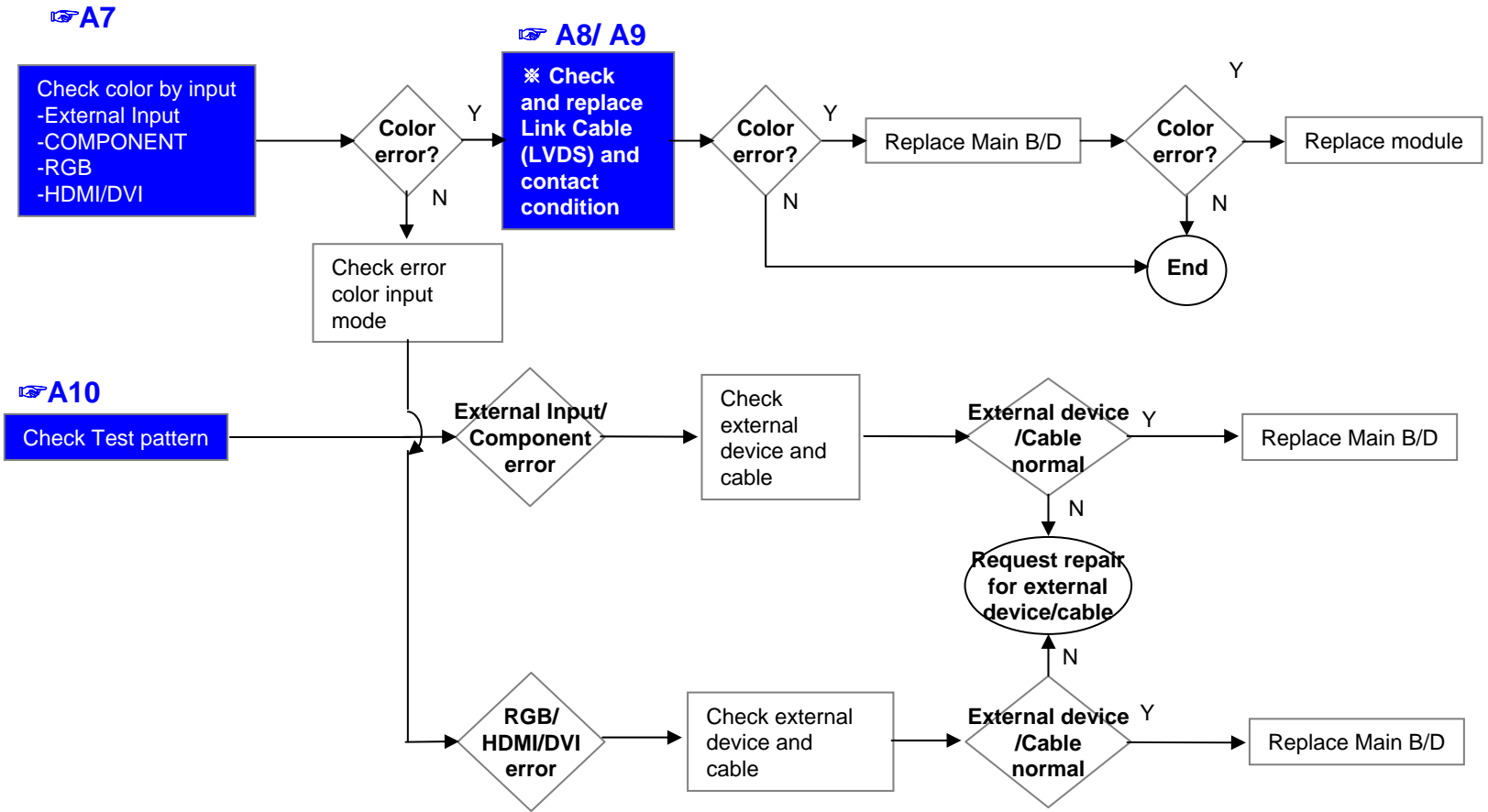

LCD TV	Error symptom	A. Video error	Established date	2012. 01 .14	
		Vertical / Horizontal bar, residual image, light spot, external device color error	Revised date		6/14

Vertical/Horizontal bar, residual image, light spot

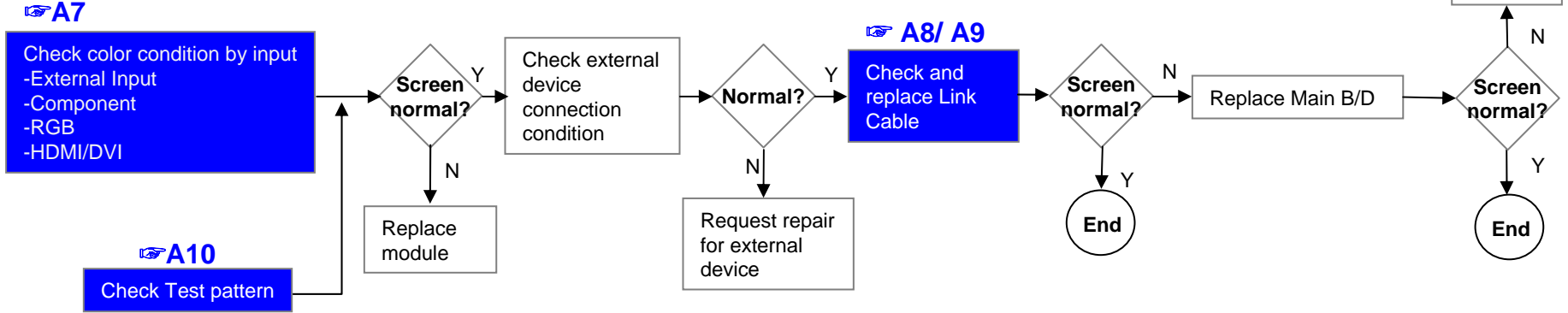

External device screen error-Color error

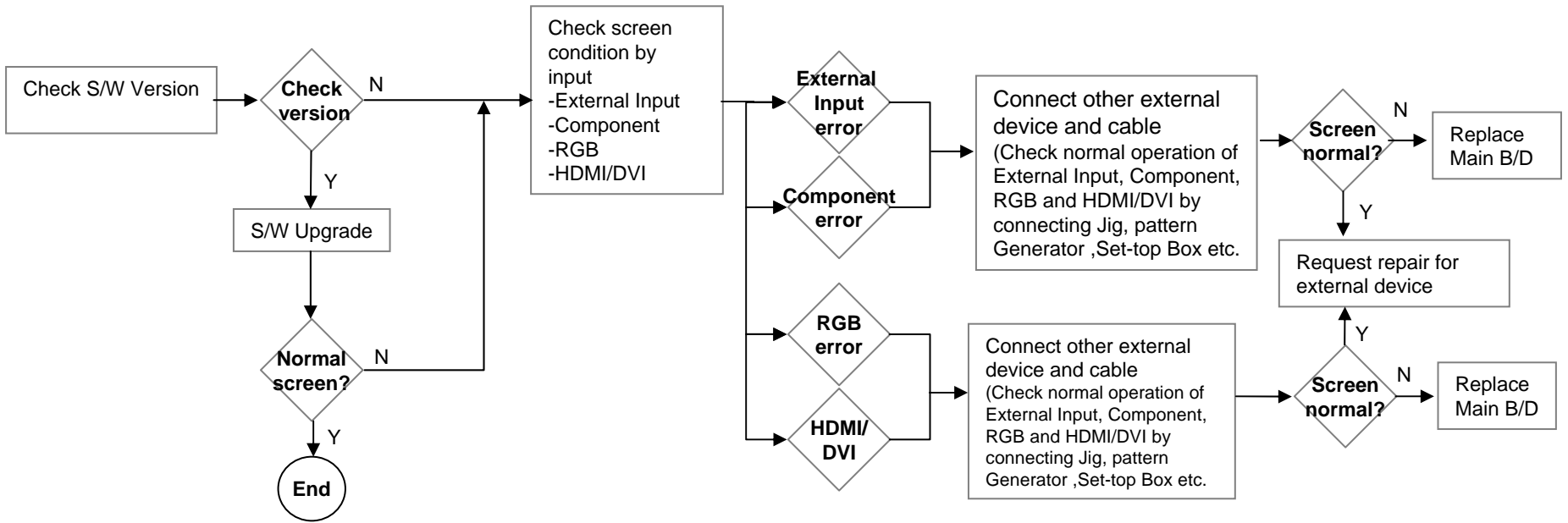

LCD TV	Error symptom	B. Power error	Established date	2012. 01 .14	
		No power	Revised date		7/14

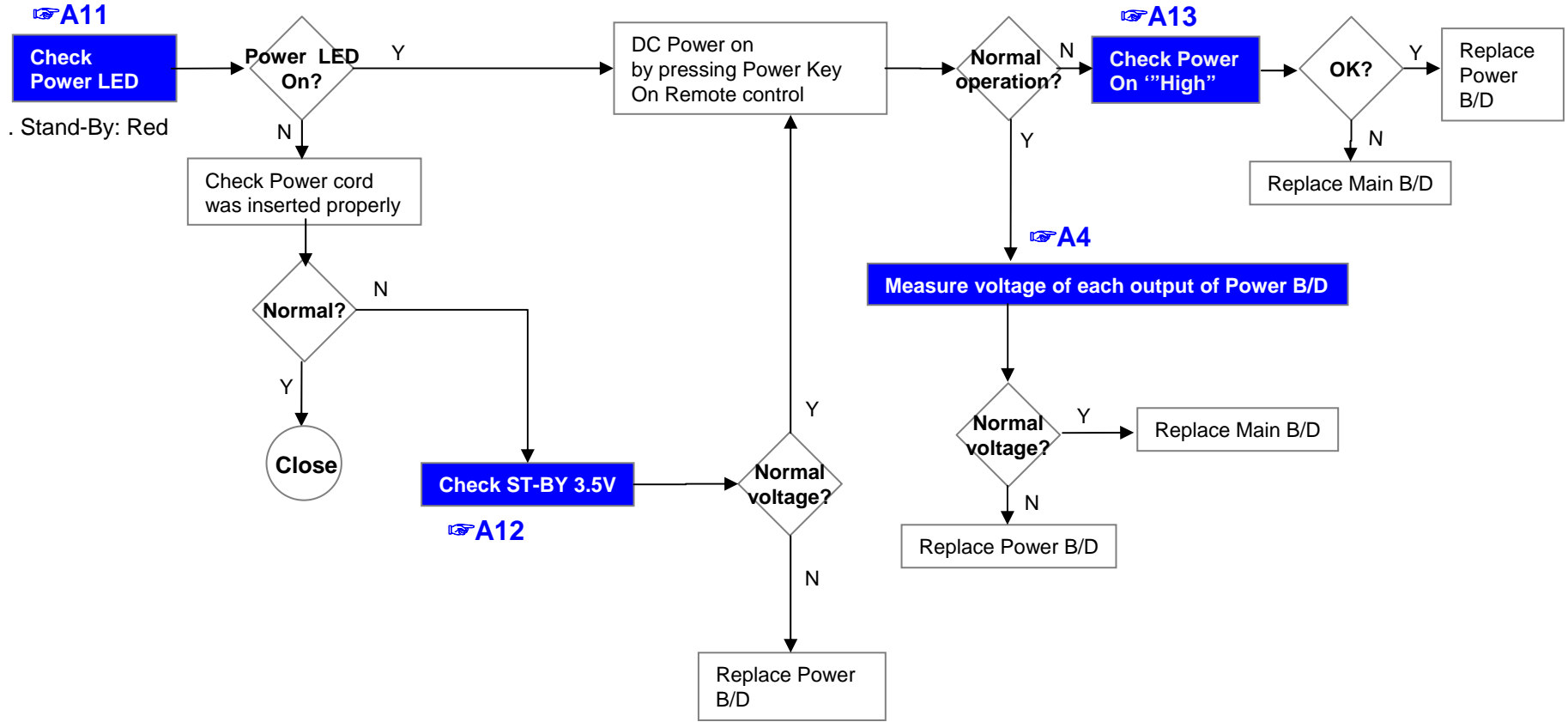

LCD TV	Error symptom	B. Power error	Established date	2012. 01 .14	
		Off when on, off while viewing, power auto on/off	Revised date		8/14

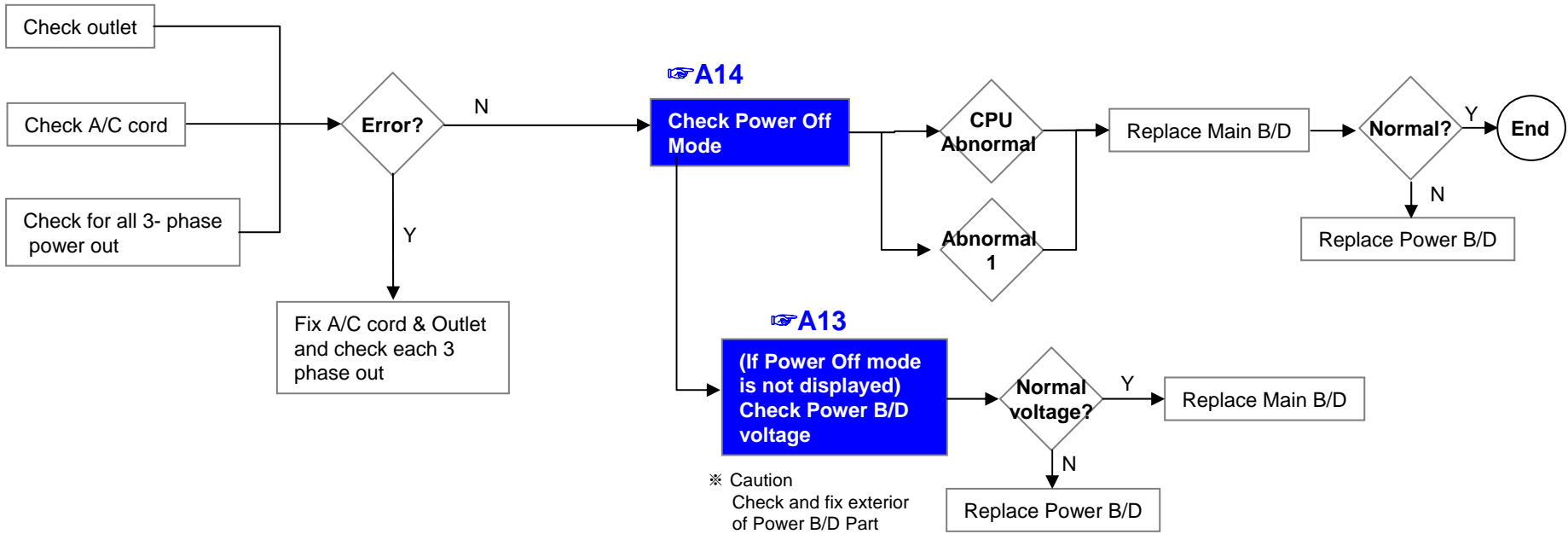

* Please refer to the all cases which can be displayed on power off mode.

Status	Power off List	Explanation
Normal	"POWEROFF_REMOTEKEY"	Power off by REMOTE CONTROL
	"POWEROFF_OFFTIMER"	Power off by OFF TIMER
	"POWEROFF_SLEEPTIMER"	Power off by SLEEP TIMER
	"POWEROFF_INSTOP"	Power off by INSTOP KEY
	"POWEROFF_AUTOOFF"	Power off by AUTO OFF
	"POWEROFF_ONTIMER"	Power off by ON TIMER
	"POWEROFF_RS232C"	Power off by RS232C
	"POWEROFF_RESREC"	Power off by Reserved Record
	"POWEROFF_RECEND"	Power off by End of Recording
	"POWEROFF_SWDOWN"	Power off by S/W Download
Abnormal	"POWEROFF_UNKNOWN"	Power off by unknown status except listed case
	"POWEROFF_ABNORMAL1"	Power off by abnormal status except CPU trouble
	"POWEROFF_CPUABNORMAL"	Power off by CPU Abnormal

LCD TV	Error symptom	C. Audio error	Established date	2012. 01 .14	
		No audio/ Normal video	Revised date		9/14

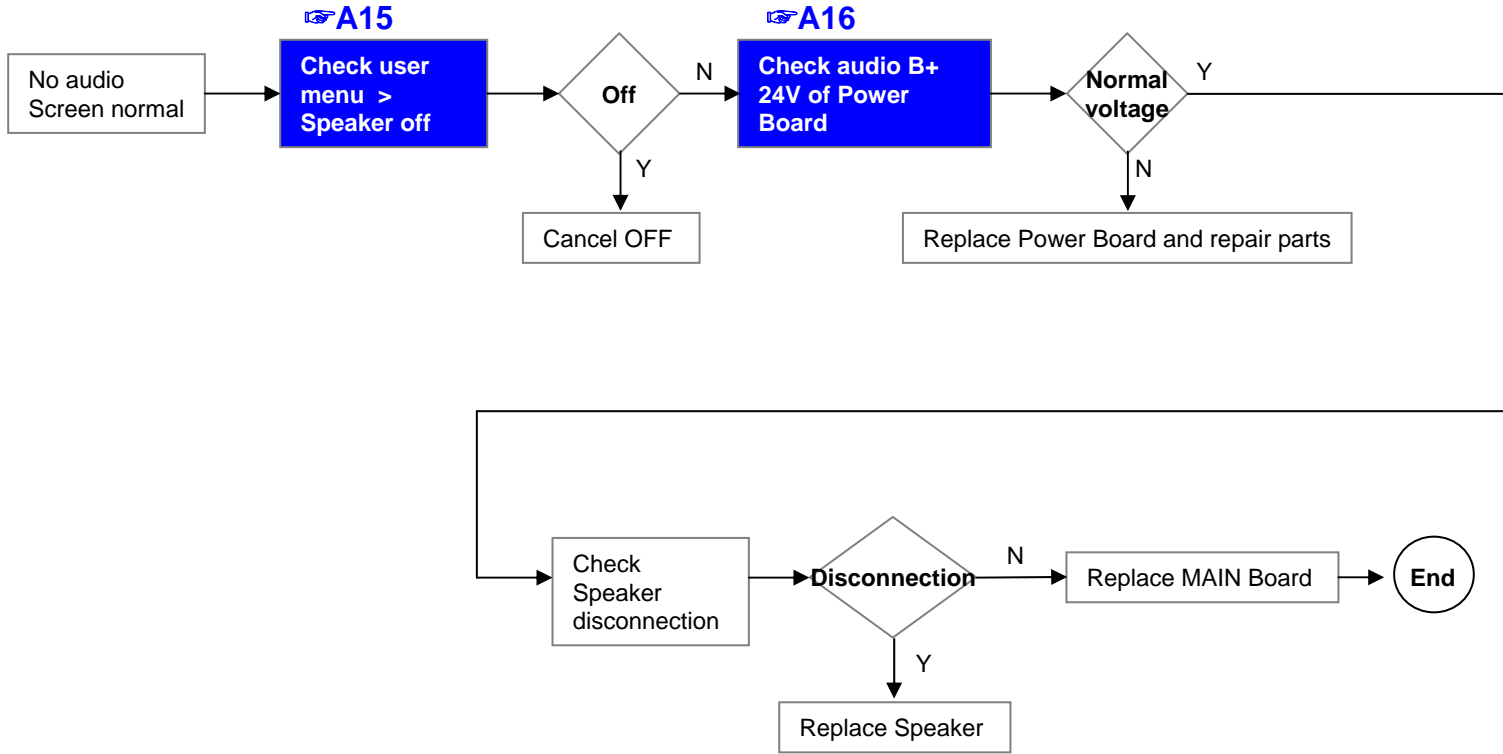

LCD TV	Error symptom	C. Audio error	Established date	2012. 01 .14
		Wrecked audio/ discontinuation/noise	Revised date	10/14

→ abnormal audio/discontinuation/noise is same after “Check input signal” compared to No audio

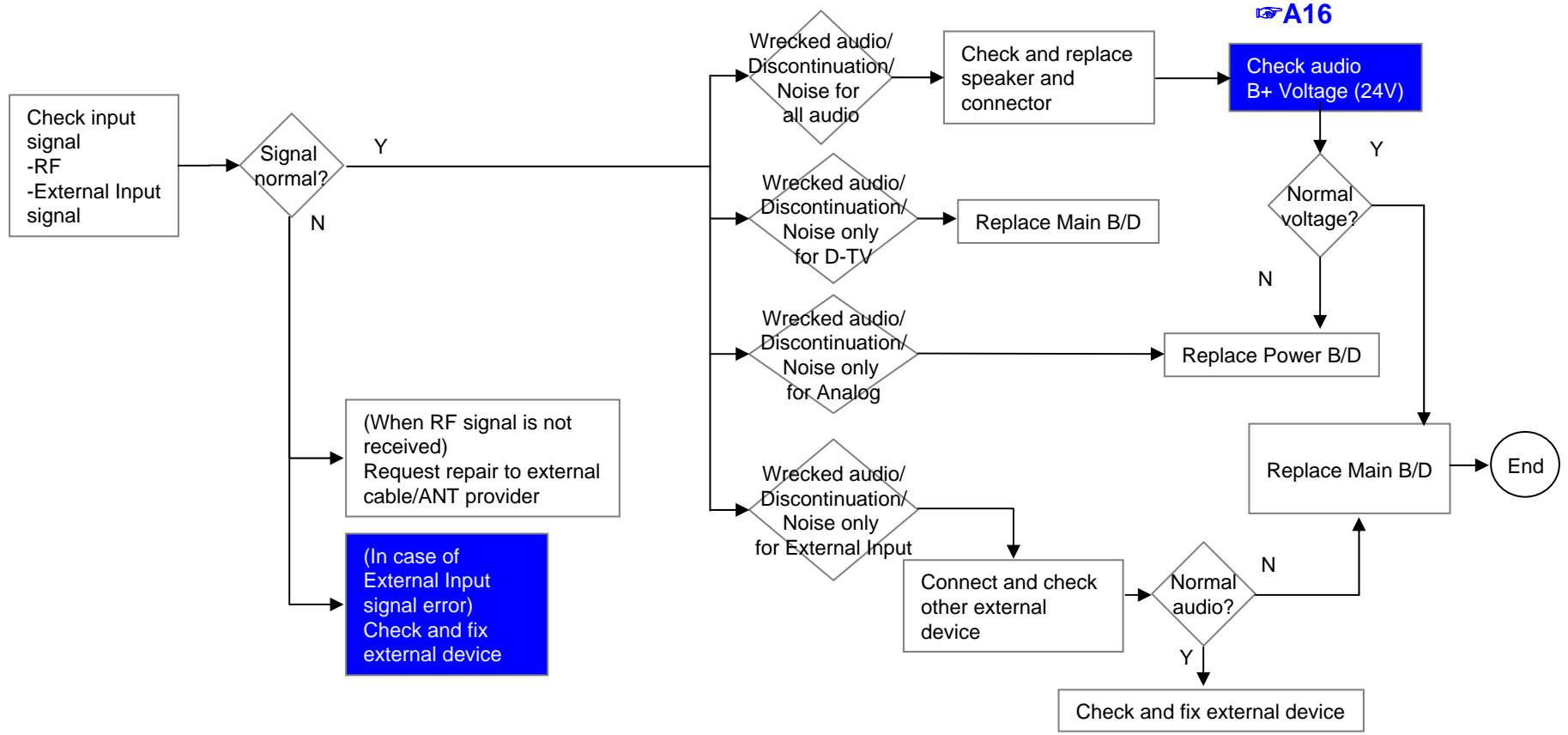

LCD TV	Error symptom	D. Function error	Established date	2012. 01 .14	
		Remote control & Local switch checking	Revised date		11/14

1. Remote control(R/C) operating error

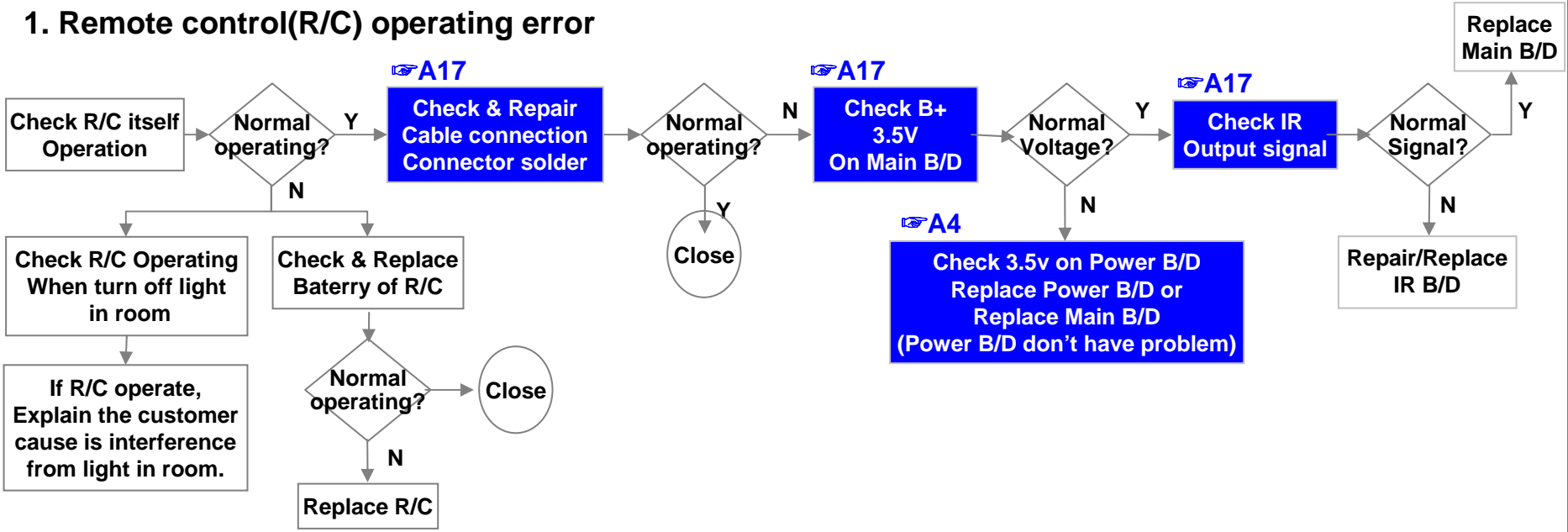

LCD TV	Error symptom	D. Function error	Established date	2012. 01 .14	
		External device recognition error	Revised date		12/14

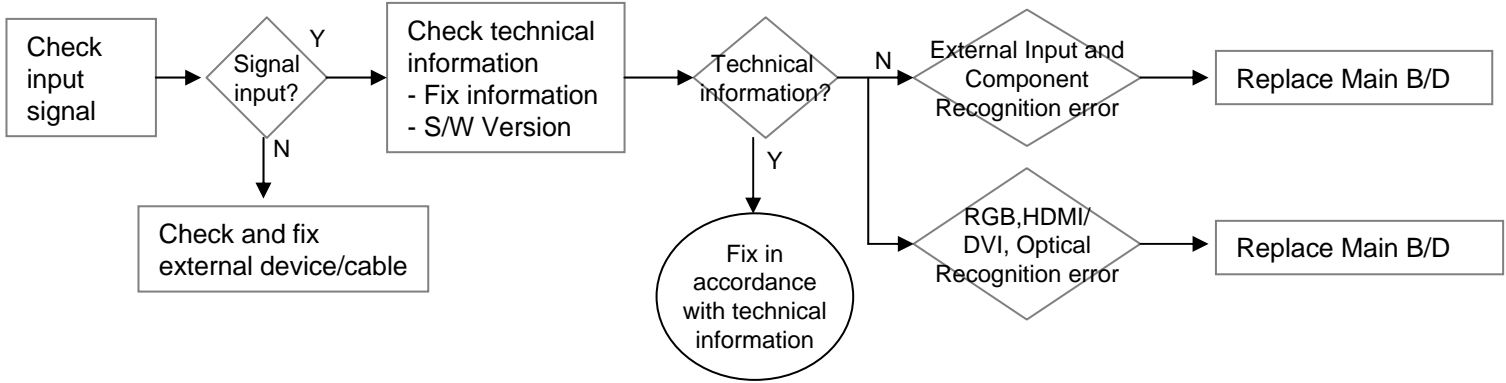

LCD TV	Error symptom	E. Noise	Established date	2012. 01 .14	
		Circuit noise, mechanical noise	Revised date		13/14

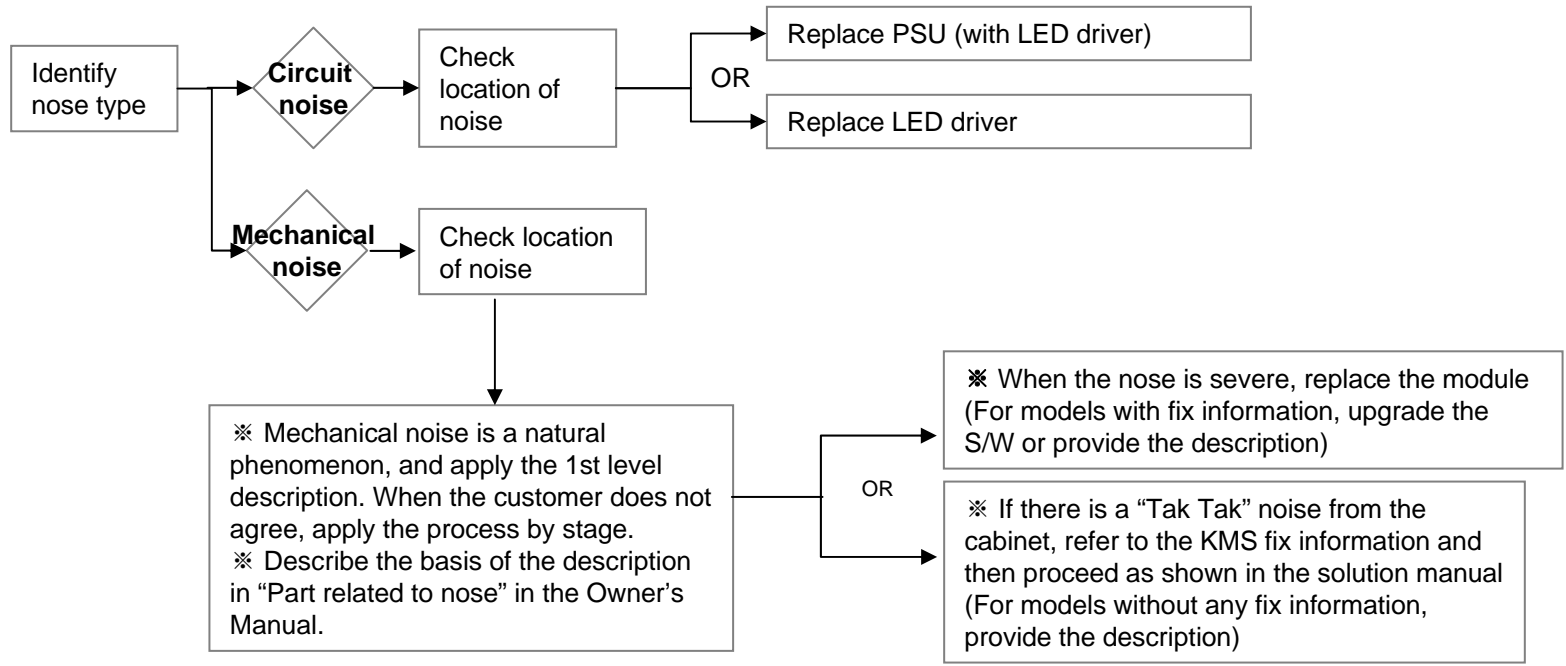

LCD TV	Error symptom	F. Exterior defect	Established date	2012. 01 .14	
		Exterior defect	Revised date		14/14

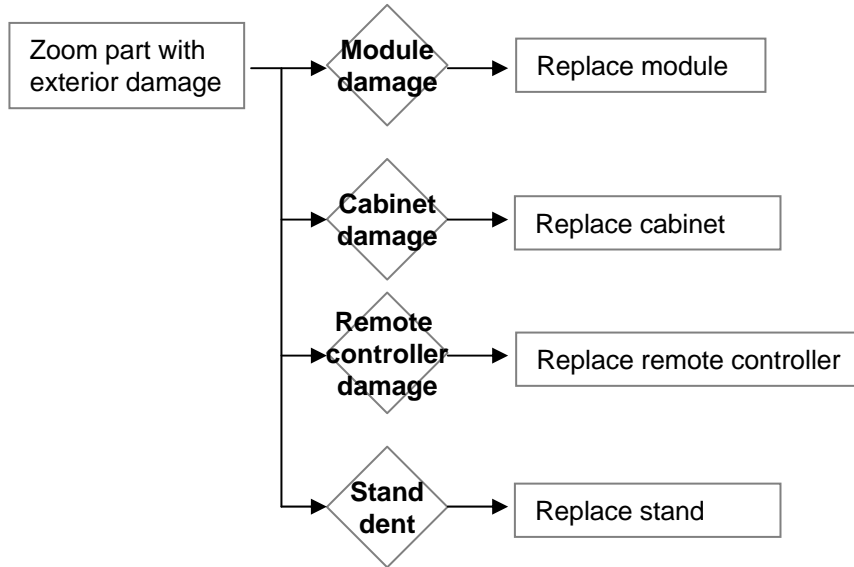



Contents of LCD TV Standard Repair Process

No.	Error symptom (High category)	Error symptom (Mid category)	Page	Remarks
1	A. Video error	No video/Normal audio	1	
2		No video/No audio	2	
3		Tuning fail, Picture broken/ Freezing	3, 4	
4		Color error	5	
5		Vertical/Horizontal bar, residual image, light spot, external device color error	6	
6	B. Power error	No power	7	
7		Off when on, off while viewing, power auto on/off	8	
8	C. Audio error	No audio/Normal video	9	
9		Wrecked audio/discontinuation/noise	10	
10	D. Function error	Remote control & Local switch checking	11	
11		External device recognition error	12	
12	E. Noise	Circuit noise, mechanical noise	13	
13	F. Exterior error	Exterior defect	14	

First of all, Check whether there is SVC Bulletin in GCSC System for these model.

Contents of LCD TV Standard Repair Process Detail Technical Manual

No.	Error symptom	Content	Page	Remarks
1	A. Video error_ No video/Normal audio	Check LCD back light with naked eye	A1	
2		LED driver B+ 24V measuring method	A2	
3		Check White Balance value	A3	
4		Power Board voltage measuring method	A4	
6	A. Video error_ No video/Video lag/stop	TUNER input signal strength checking method	A5	
7		LCD-TV Version checking method	A6	
9	A. Video error_Color error	LCD TV connection diagram	A7	
10		Check Link Cable (LVDS) reconnection condition	A8 A9	
11		Adjustment Test pattern – ADJ Key	A10	
12	A. Video error_Vertical/Horizontal bar, residual image, light spot	LCD TV connection diagram	A8	
13		Check Link Cable (LVDS) reconnection condition	A8 A9	
14		Adjustment Test pattern – ADJ Key	A10	
15	<Appendix> Defected Type caused by T-Con/ Inverter/ Module	Exchange T-Con Board (1)	A-1/5	
16		Exchange T-Con Board (2)	A-2/5	
17		Exchange LED driver Board (PSU)	A-3/5	55" : driver board Other : PSU
18		Exchange Module itself (1)	A-4/5	
19		Exchange Module itself (2)	A-5/5	

Continue to the next page

LCD TV	Error symptom	A. Video error	Established date	2012. 01 .14	
		No video/ Normal audio	Revised date		1/14

**First of all, Check whether all of cables between board is inserted properly or not.
(Main B/D ↔ Power B/D, LVDS Cable, Speaker Cable, IR B/D Cable,,)**

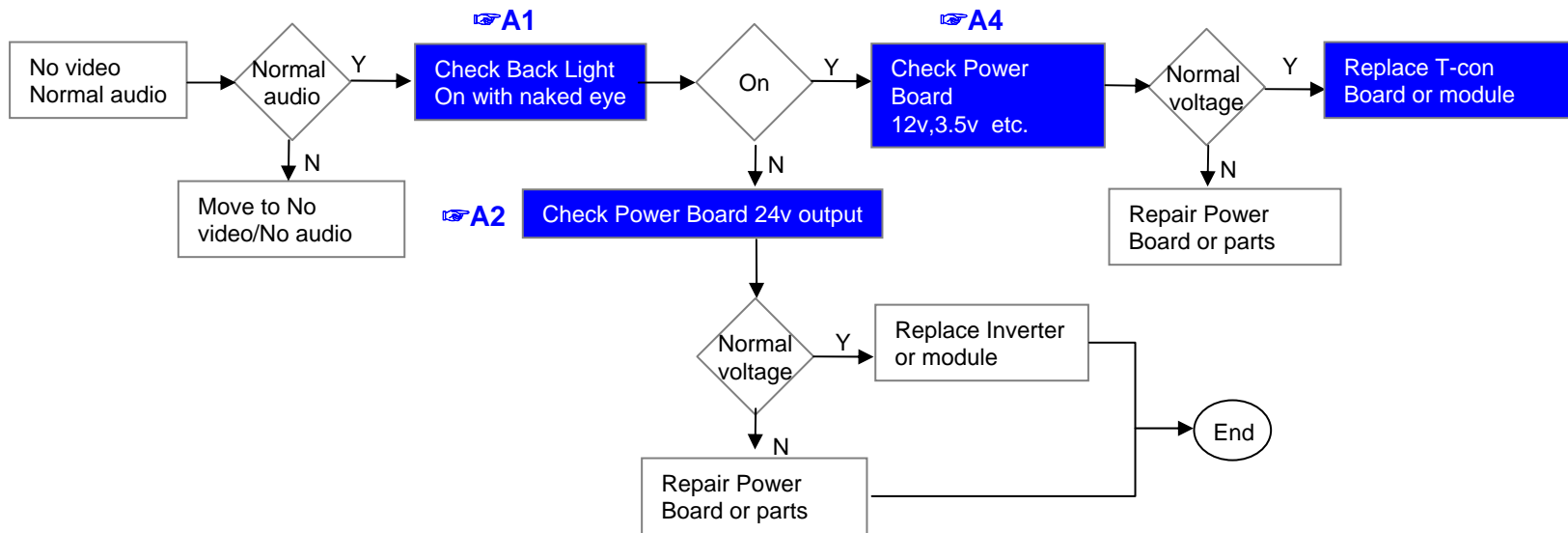

※Precaution A6 & A3

Always check & record S/W Version and White Balance value before replacing the Main Board

Replace Main Board

Re-enter White Balance value

LCD TV	Error symptom	A. Video error	Established date	2012 . 01	
		No video/ No audio	Revised date	.14	2/14

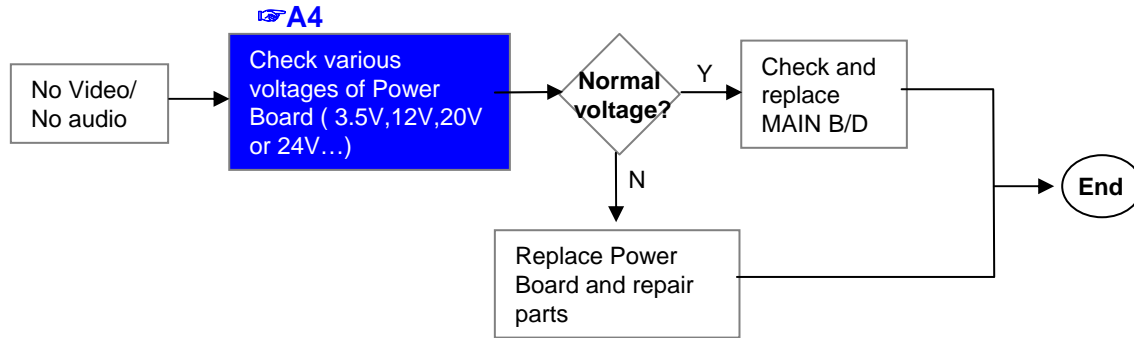

LCD TV	Error symptom	A. Video error	Established date	2012. 01 .14	
		Picture broken/ Freezing	Revised date		3/14

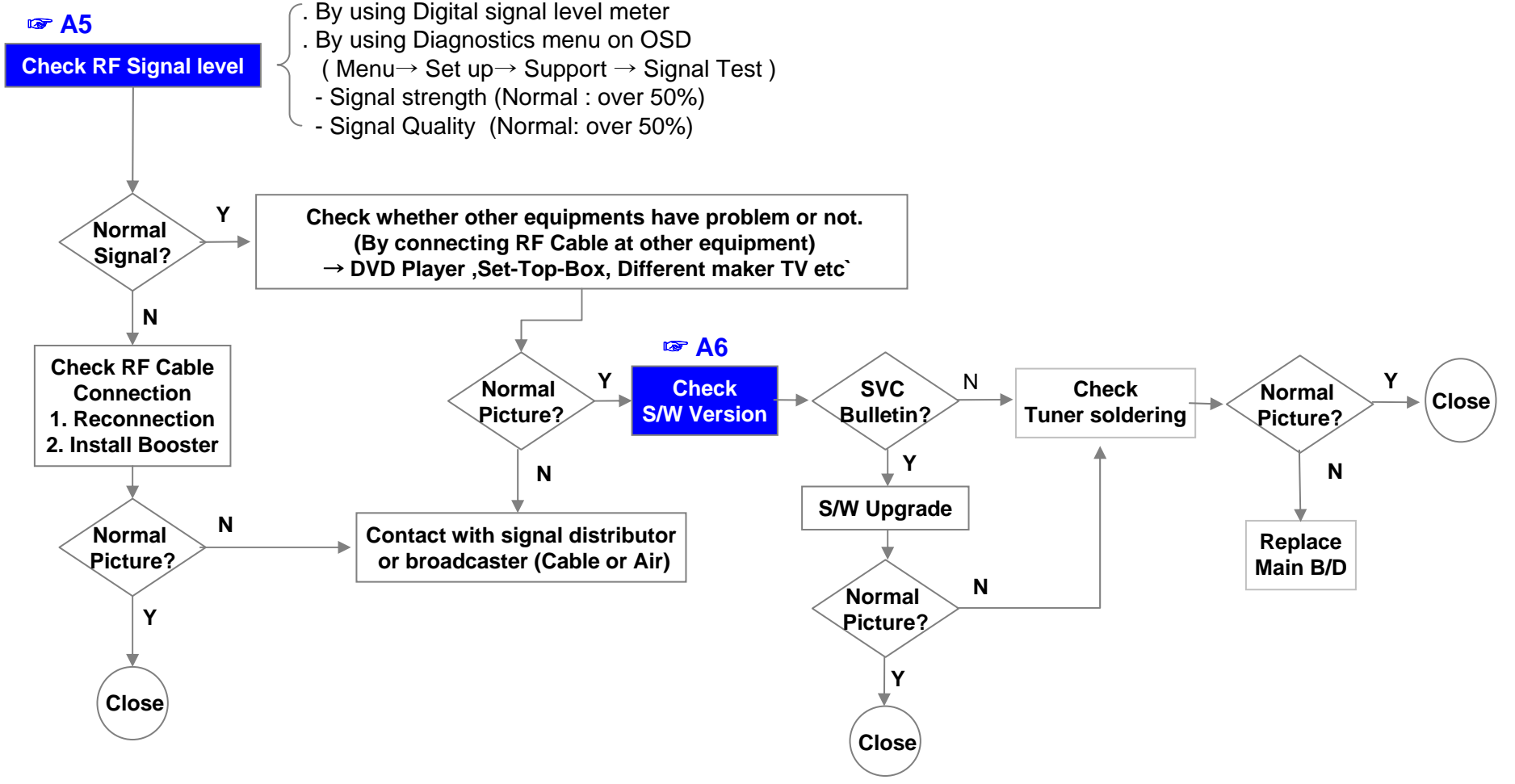

LCD TV	Error symptom	A. Video error	Established date	2012. 01 .14	
		Tuning fail, Picture broken/ Freezing	Revised date		4/14

A5

Check RF Signal level

Check RF signal cable (DVB satellite signal or not)
 Check whether other equipments have problem or not.
 (By connecting RF Cable at other equipment)
 → Set-Top-Box, Different maker TV etc

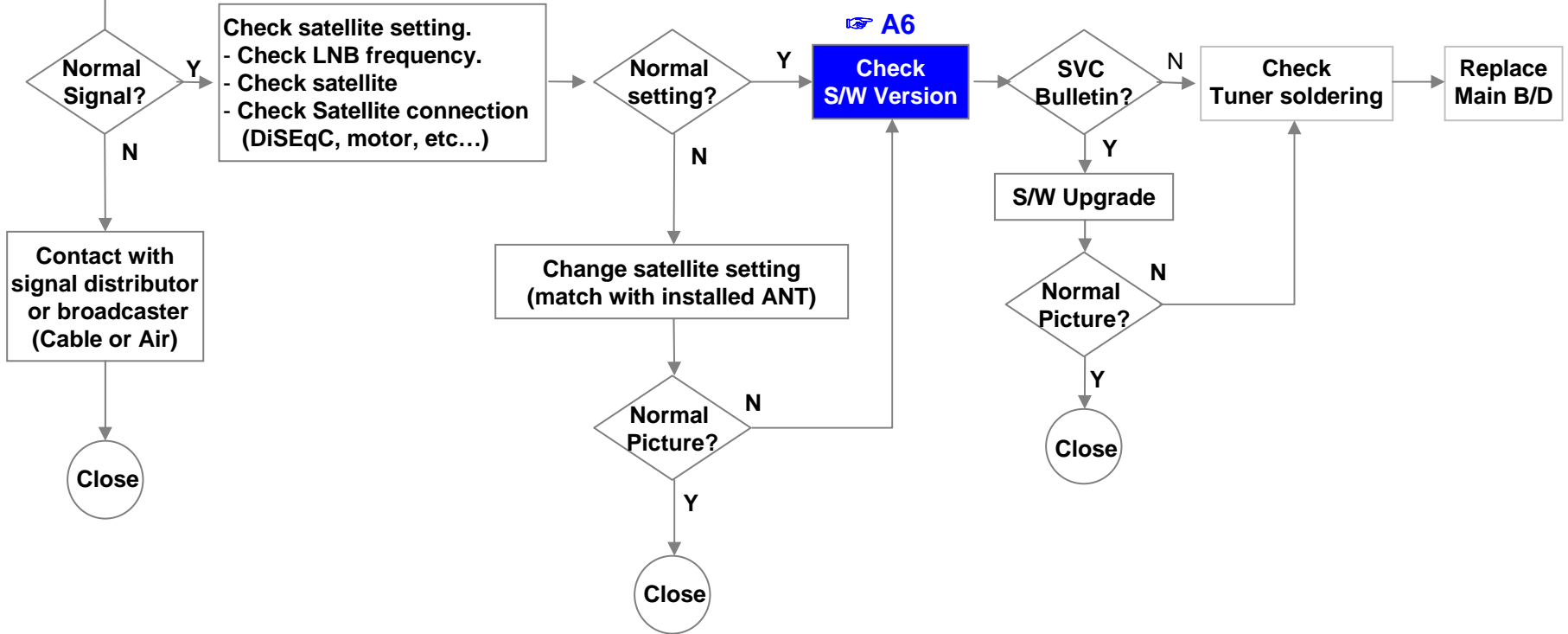

LCD TV	Error symptom	A. Video error	Established date	2012. 01 .14	
		Color error	Revised date		5/14

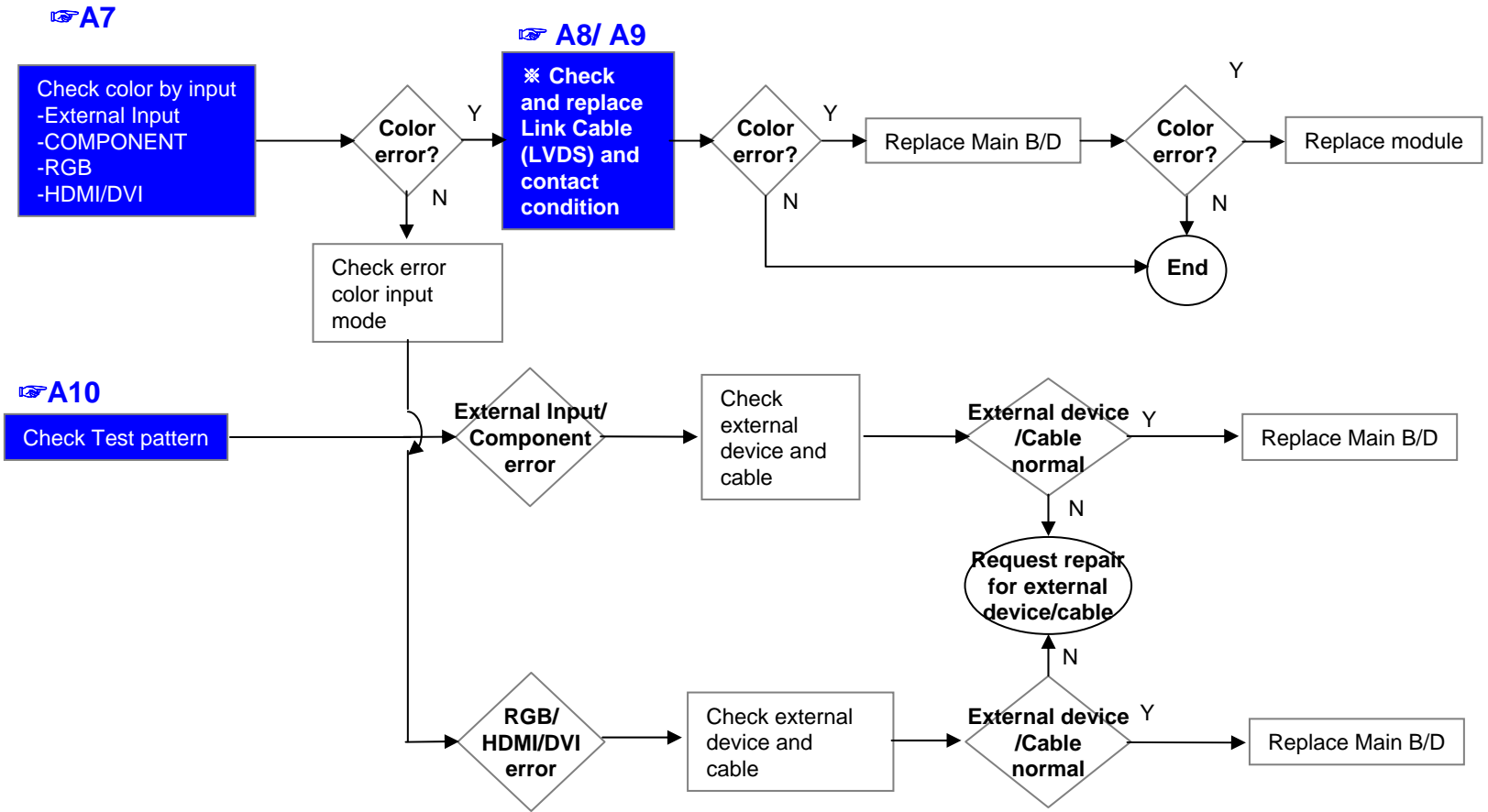

LCD TV	Error symptom	A. Video error	Established date	2012. 01 .14	
		Vertical / Horizontal bar, residual image, light spot, external device color error	Revised date		6/14

Vertical/Horizontal bar, residual image, light spot

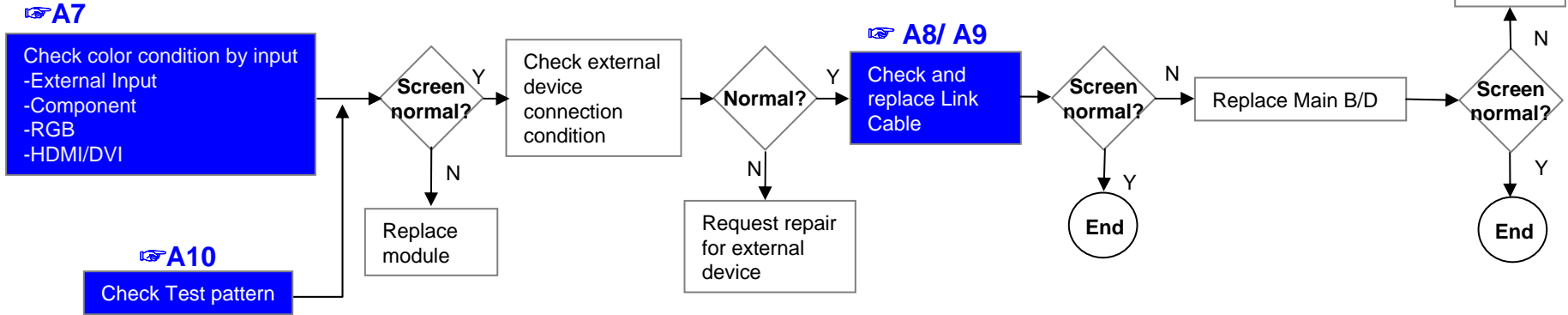

External device screen error-Color error

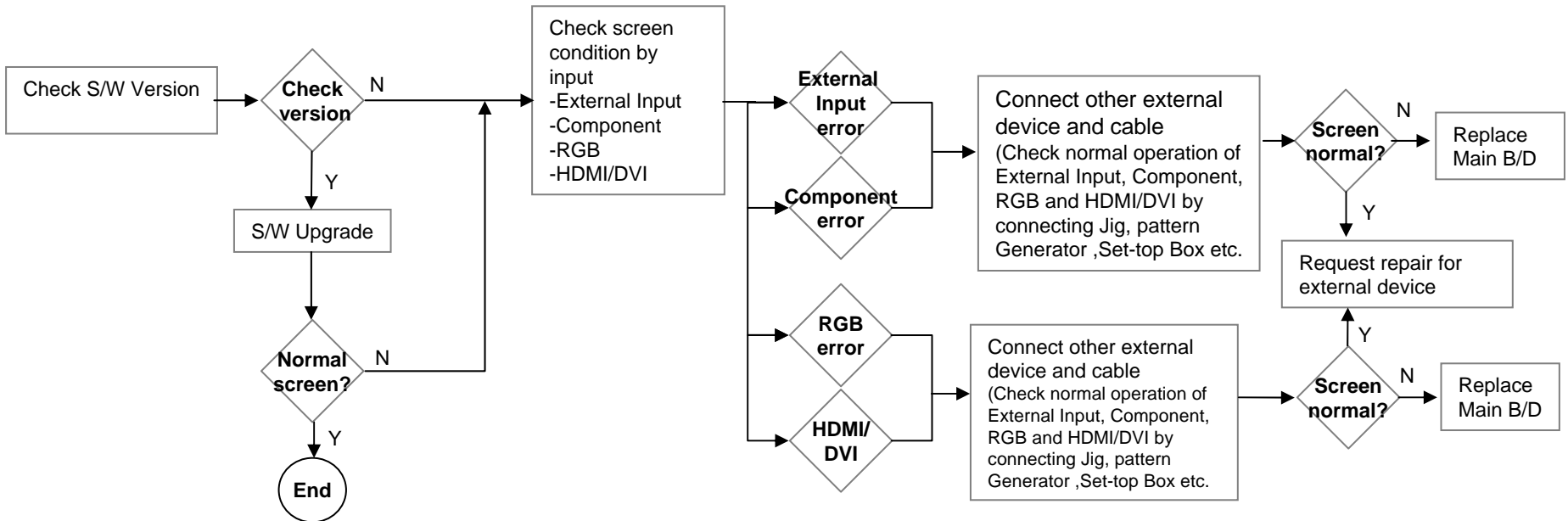

LCD TV	Error symptom	B. Power error	Established date	2012. 01 .14	
		No power	Revised date		7/14

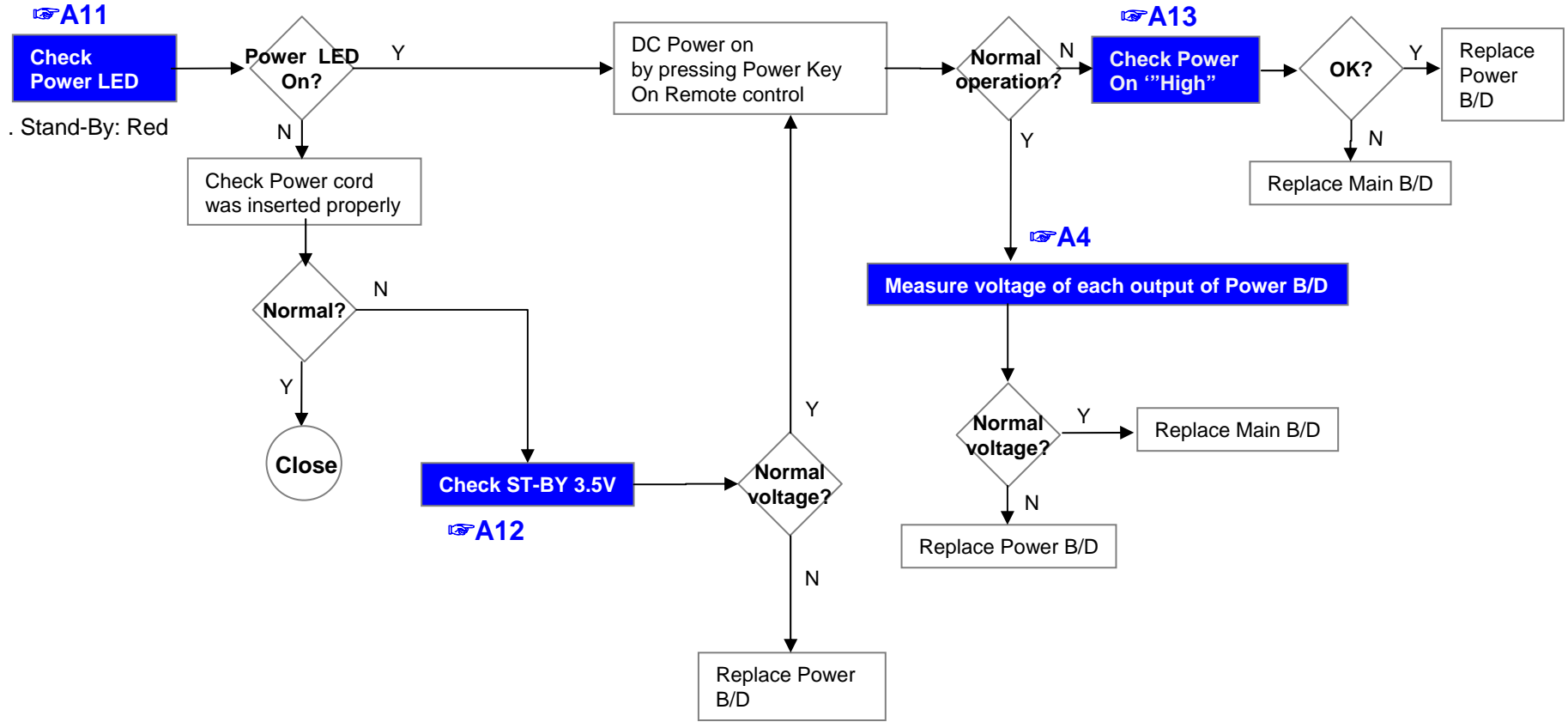

LCD TV	Error symptom	B. Power error	Established date	2012. 01 .14	
		Off when on, off while viewing, power auto on/off	Revised date		8/14

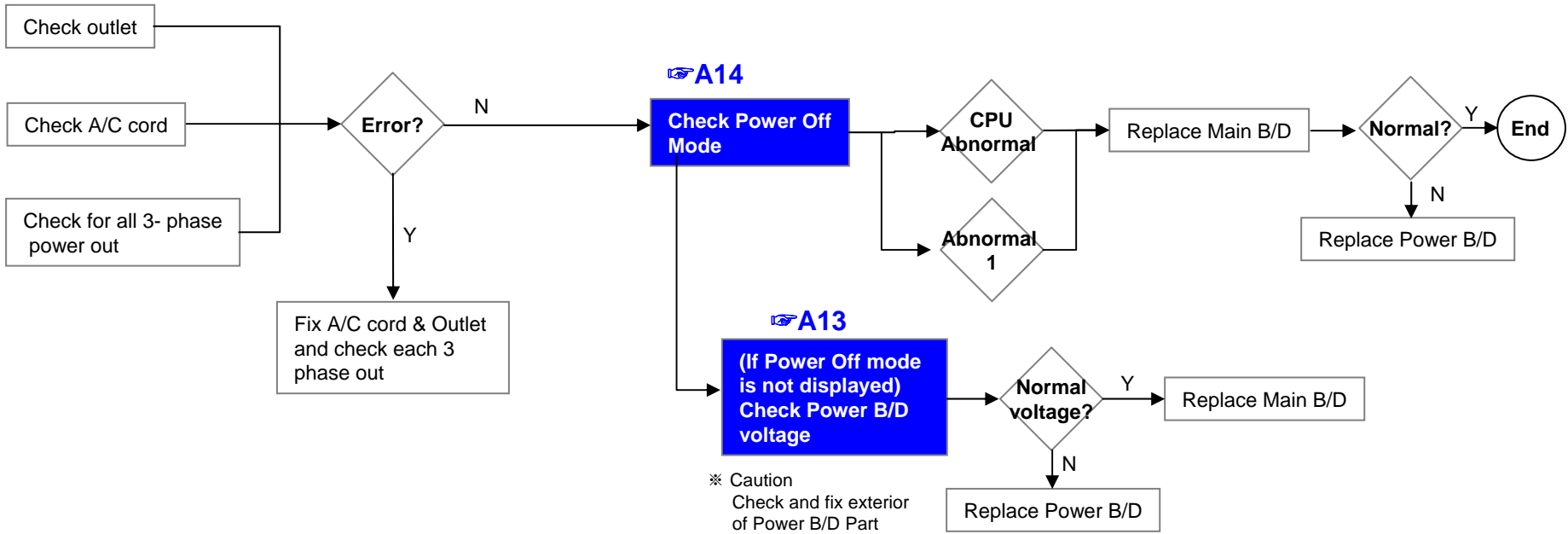

* Please refer to the all cases which can be displayed on power off mode.

Status	Power off List	Explanation
Normal	"POWEROFF_REMOTEKEY"	Power off by REMOTE CONTROL
	"POWEROFF_OFFTIMER"	Power off by OFF TIMER
	"POWEROFF_SLEEPTIMER"	Power off by SLEEP TIMER
	"POWEROFF_INSTOP"	Power off by INSTOP KEY
	"POWEROFF_AUTOOFF"	Power off by AUTO OFF
	"POWEROFF_ONTIMER"	Power off by ON TIMER
	"POWEROFF_RS232C"	Power off by RS232C
	"POWEROFF_RESREC"	Power off by Reserved Record
	"POWEROFF_RECEND"	Power off by End of Recording
	"POWEROFF_SWDOWN"	Power off by S/W Download
Abnormal	"POWEROFF_UNKNOWN"	Power off by unknown status except listed case
	"POWEROFF_ABNORMAL1"	Power off by abnormal status except CPU trouble
	"POWEROFF_CPUABNORMAL"	Power off by CPU Abnormal

LCD TV	Error symptom	C. Audio error	Established date	2012. 01 .14	
		No audio/ Normal video	Revised date		9/14

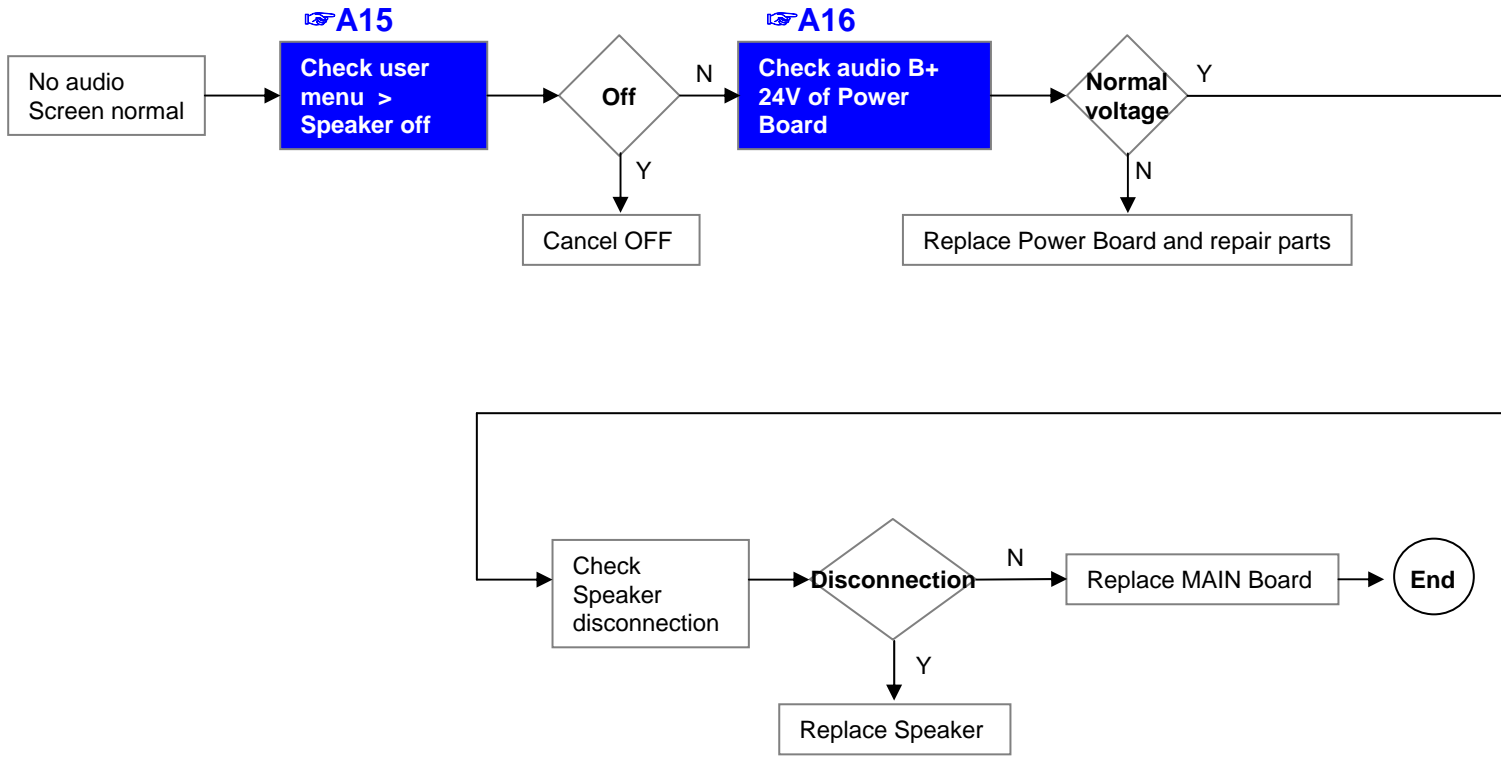

LCD TV	Error symptom	C. Audio error	Established date	2012. 01 .14
		Wrecked audio/ discontinuation/noise	Revised date	10/14

→ abnormal audio/discontinuation/noise is same after “Check input signal” compared to No audio

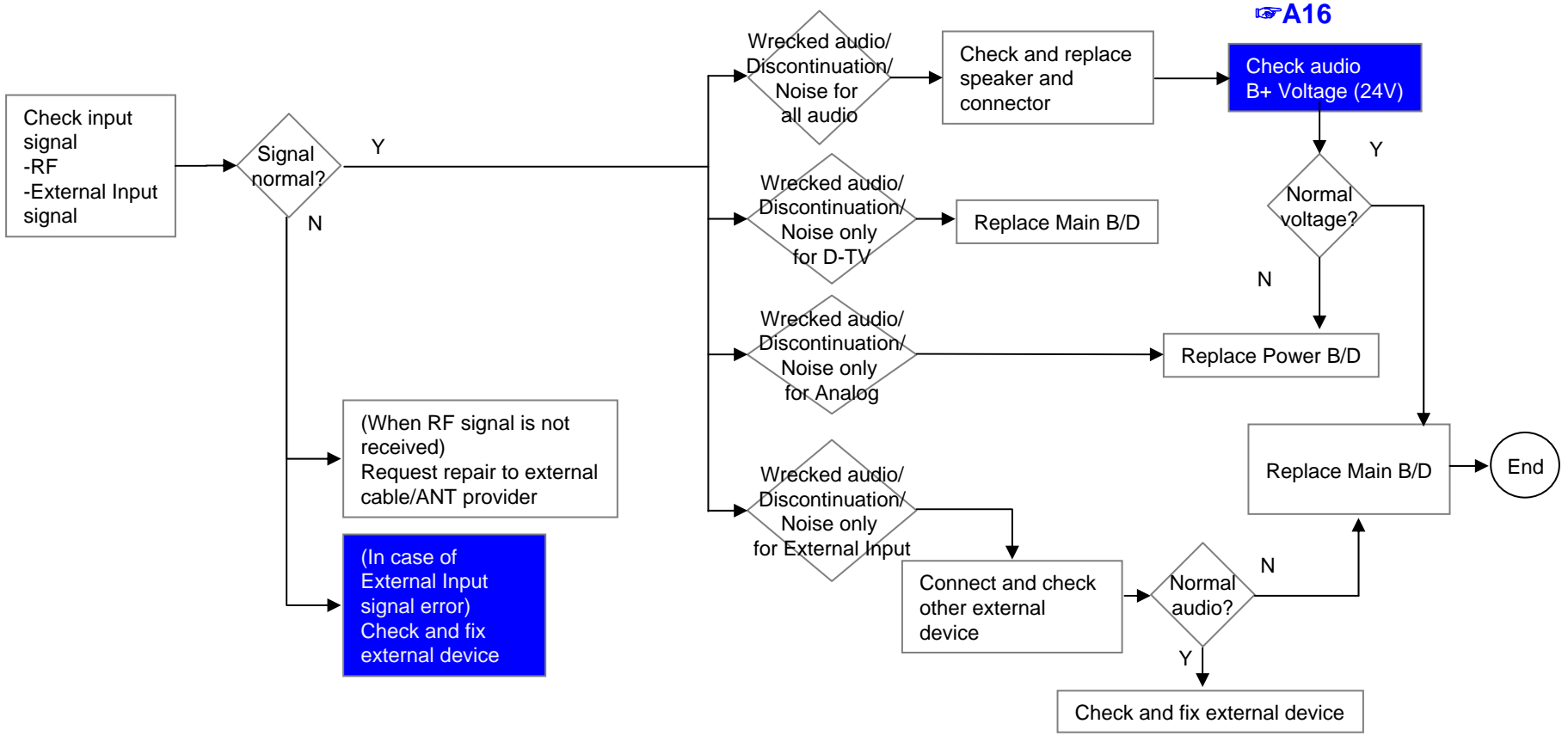

LCD TV	Error symptom	D. Function error	Established date	2012. 01 .14	
		Remote control & Local switch checking	Revised date		11/14

1. Remote control(R/C) operating error

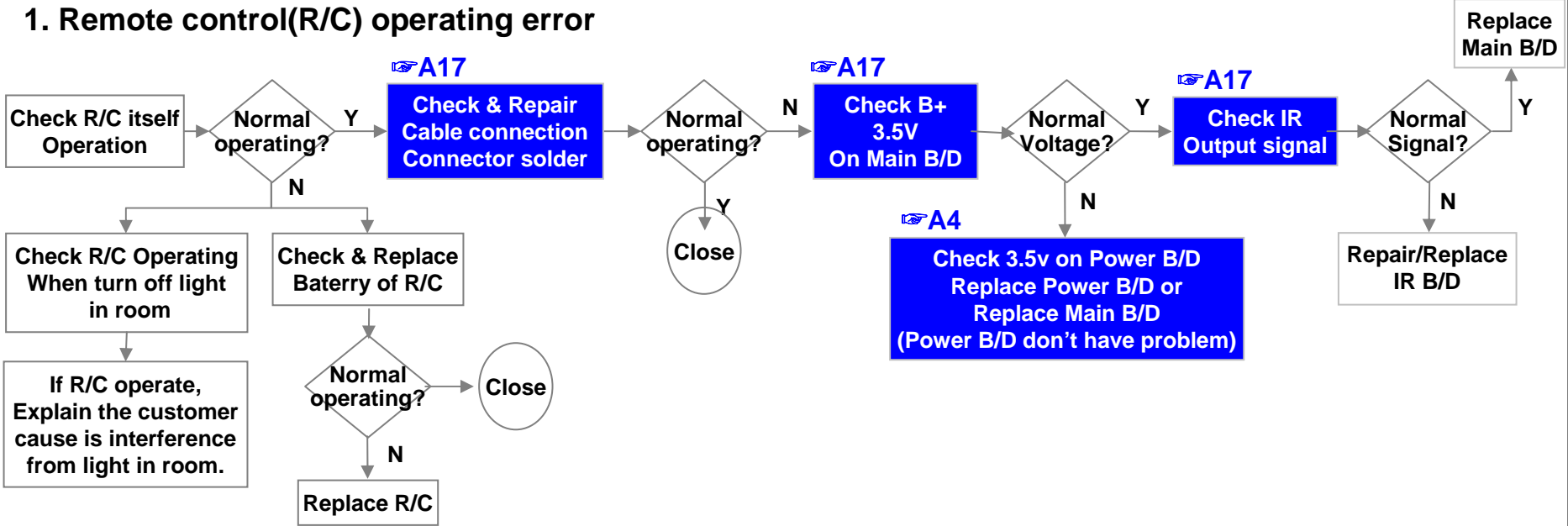

LCD TV	Error symptom	D. Function error	Established date	2012. 01 .14	
		External device recognition error	Revised date		12/14

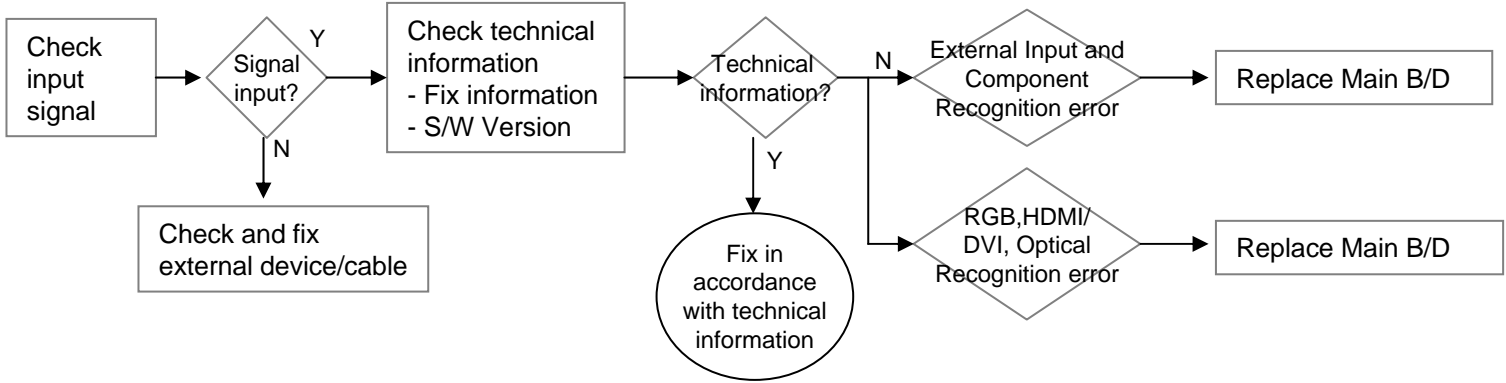

LCD TV	Error symptom	E. Noise	Established date	2012. 01 .14	
		Circuit noise, mechanical noise	Revised date		13/14

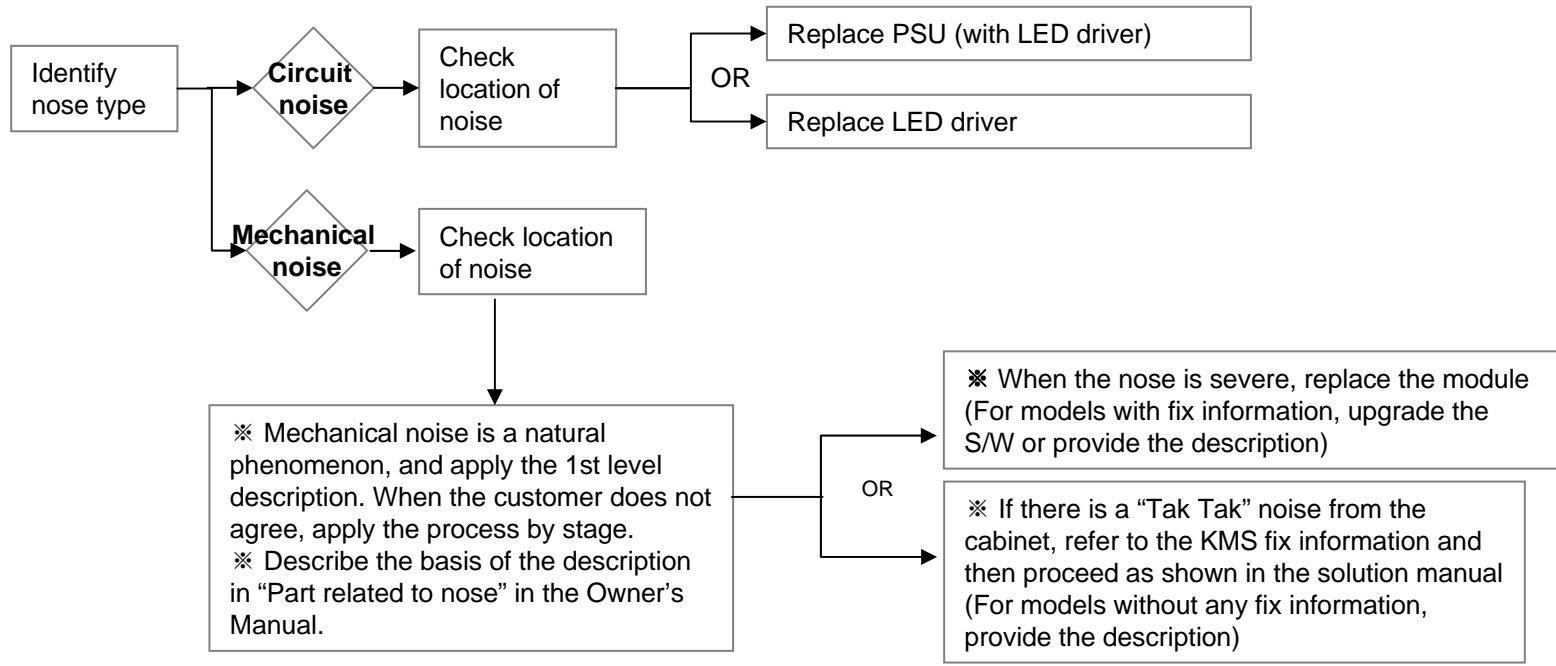

LCD TV	Error symptom	F. Exterior defect	Established date	2012. 01 .14	
		Exterior defect	Revised date		14/14

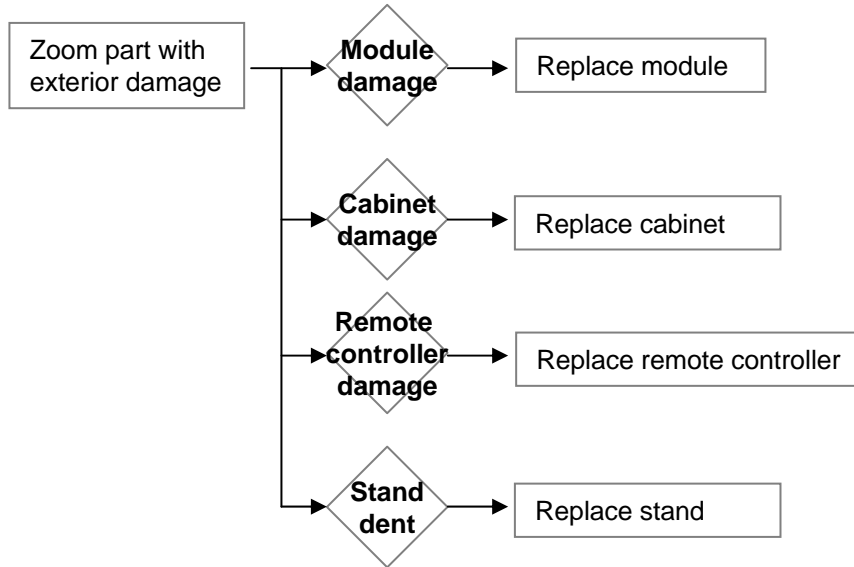

Free Manuals Download Website

<http://myh66.com>

<http://usermanuals.us>

<http://www.somanuals.com>

<http://www.4manuals.cc>

<http://www.manual-lib.com>

<http://www.404manual.com>

<http://www.luxmanual.com>

<http://aubethermostatmanual.com>

Golf course search by state

<http://golfingnear.com>

Email search by domain

<http://emailbydomain.com>

Auto manuals search

<http://auto.somanuals.com>

TV manuals search

<http://tv.somanuals.com>