



Service Manual

Lexmark X73 Scan/Print/Copy

4402-001

- ***Table of Contents***
- ***Start Diagnostics***
- ***Safety and Notices***
- ***Trademarks***
- ***Index***

LEXMARK™

Lexmark and Lexmark with diamond design are trademarks of Lexmark International, Inc., registered in the United States and/or other countries.

4402-001

Edition: June 2001

The following paragraph does not apply to any country where such provisions are inconsistent with local law: LEXMARK INTERNATIONAL, INC. PROVIDES THIS PUBLICATION "AS IS" WITHOUT WARRANTY OF ANY KIND, EITHER EXPRESS OR IMPLIED, INCLUDING, BUT NOT LIMITED TO, THE IMPLIED WARRANTIES OF MERCHANTABILITY OR FITNESS FOR A PARTICULAR PURPOSE. Some states do not allow disclaimer of express or implied warranties in certain transactions; therefore, this statement may not apply to you.

This publication could include technical inaccuracies or typographical errors. Changes are periodically made to the information herein; these changes will be incorporated in later editions. Improvements or changes in the products or the programs described may be made at any time.

Comments may be addressed to Lexmark International, Inc., Department D22A/032-2, 740 West New Circle Road, Lexington, Kentucky 40550, U.S.A or e-mail at ServiceInfoAndTraining@Lexmark.com. Lexmark may use or distribute any of the information you supply in any way it believes appropriate without incurring any obligation to you. You can purchase additional copies of publications related to this product by calling 1-800-553-9727. In other countries, contact your point of purchase.

Lexmark is a trademark of Lexmark International, Inc., registered in the United States and/or other countries.

Other trademarks are the property of their respective owners.

© Copyright Lexmark International, Inc. 2001.

All rights reserved.

UNITED STATES GOVERNMENT RESTRICTED RIGHTS

This software and documentation are provided with RESTRICTED RIGHTS. Use, duplication or disclosure by the Government is subject to restrictions as set forth in subparagraph (c)(1)(ii) of the Rights in Technical Data and Computer Software clause at DFARS 252.227-7013 and in applicable FAR provisions: Lexmark International, Inc., Lexington, KY 40550.

U.S.A. P/N: 12G3798

Table of Contents

Safety Information	v
Preface	x
General Information	1-1
Power Consumption	1-1
Scanner Specifications	1-2
Operator Panel	1-3
Maintenance Approach	1-4
Abbreviations	1-4
Diagnostic Information	2-1
Start	2-1
Power-On Self Test (POST) Sequence	2-1
POST Symptom Table	2-2
Symptom Tables	2-3
Service Checks	2-6
Carrier Transport Service Check	2-6
CCD Module Assembly Service Check	2-8
Gear Train Assembly Service Check	2-9
Maintenance Station Service Check	2-10
Paper Feed Service Check	2-11
Paper Path Service Check	2-13
Power Service Check	2-14
Print Quality Service Check	2-15
Scan/Copy Quality Service Check	2-17
Diagnostic Aids	3-1
Test Page	3-1
Repair Information	4-1
Handling ESD-Sensitive Parts	4-1
Adjustments	4-2

Removal Procedures	4-2
Releasing Plastic Latches	4-2
Scanner Lid Assembly Removal	4-3
Rear Cover Removal	4-3
Operator Panel Removal	4-4
Top Housing Assembly Removal	4-4
Paper Support Removal	4-4
CCD Module Assembly Removal	4-5
Gear Train Assembly Removal	4-6
Access Cover Sensor Removal	4-6
Right Cover Removal	4-7
Access Cover Removal	4-7
Left Cover Removal	4-8
Middle Frame Removal	4-9
Print Engine Removal	4-11
ASF Module Removal	4-12
System Board Removal	4-12
Carrier Removal	4-13
Encoder Strip Removal	4-13
Maintenance Station Removal	4-14
Belt/Idler Pulley Assembly (Print Engine) Removal	4-14
Connector Locations	5-1
Preventive Maintenance	6-1
Lubrication Specifications	6-1
Parts Catalog	7-1
Assembly 1: Covers	7-2
Assembly 2: Paper Feed, Frame and Carrier Transport	7-6
Assembly 3: Electronics	7-8
Index	I-1

Safety Information

- This product is designed, tested and approved to meet strict global safety standards with the use of specific Lexmark components. The safety features of some parts may not always be obvious. Lexmark is not responsible for the use of other replacement parts.
- The maintenance information for this product has been prepared for use by a professional service person and is not intended to be used by others.
- There may be an increased risk of electric shock and personal injury during disassembly and servicing of this product. Professional service personnel should understand this and take necessary precautions.

Consignes de Sécurité

- Ce produit a été conçu, testé et approuvé pour respecter les normes strictes de sécurité globale lors de l'utilisation de composants Lexmark spécifiques. Les caractéristiques de sécurité de certains éléments ne sont pas toujours évidentes. Lexmark ne peut être tenu responsable de l'utilisation d'autres pièces de rechange.
- Les consignes d'entretien et de réparation de ce produit s'adressent uniquement à un personnel de maintenance qualifié.
- Le démontage et l'entretien de ce produit pouvant présenter certains risques électriques, le personnel d'entretien qualifié devra prendre toutes les précautions nécessaires.

Norme di sicurezza

- Il prodotto è stato progettato, testato e approvato in conformità a severi standard di sicurezza e per l'utilizzo con componenti Lexmark specifici. Le caratteristiche di sicurezza di alcune parti non sempre sono di immediata comprensione. Lexmark non è responsabile per l'utilizzo di parti di ricambio di altri produttori.
- Le informazioni riguardanti la manutenzione di questo prodotto sono indirizzate soltanto al personale di assistenza autorizzato.
- Durante lo smontaggio e la manutenzione di questo prodotto, il rischio di subire scosse elettriche e danni alla persona è più elevato. Il personale di assistenza autorizzato, deve, quindi, adottare le precauzioni necessarie.

Sicherheitshinweise

- Dieses Produkt und die zugehörigen Komponenten wurden entworfen und getestet, um beim Einsatz die weltweit gültigen Sicherheitsanforderungen zu erfüllen. Die sicherheitsrelevanten Funktionen der Bauteile und Optionen sind nicht immer offensichtlich. Sofern Teile eingesetzt werden, die nicht von Lexmark sind, wird von Lexmark keinerlei Verantwortung oder Haftung für dieses Produkt übernommen.
- Die Wartungsinformationen für dieses Produkt sind ausschließlich für die Verwendung durch einen Wartungsfachmann bestimmt.
- Während des Auseinandernehmens und der Wartung des Geräts besteht ein zusätzliches Risiko eines elektrischen Schlags und körperlicher Verletzung. Das zuständige Fachpersonal sollte entsprechende Vorsichtsmaßnahmen treffen.

Pautas de Seguridad

- Este producto se ha diseñado, verificado y aprobado para cumplir los más estrictos estándares de seguridad global usando los componentes específicos de Lexmark. Puede que las características de seguridad de algunas piezas no sean siempre evidentes. Lexmark no se hace responsable del uso de otras piezas de recambio.
- La información sobre el mantenimiento de este producto está dirigida exclusivamente al personal cualificado de mantenimiento.
- Existe mayor riesgo de descarga eléctrica y de daños personales durante el desmontaje y la reparación de la máquina. El personal cualificado debe ser consciente de este peligro y tomar las precauciones necesarias.

Informações de Segurança

- Este produto foi concebido, testado e aprovado para satisfazer os padrões globais de segurança na utilização de componentes específicos da Lexmark. As funções de segurança de alguns dos componentes podem não ser sempre óbvias. A Lexmark não é responsável pela utilização de outros componentes de substituição.
- As informações de segurança relativas a este produto destinam-se a profissionais destes serviços e não devem ser utilizadas por outras pessoas.
- Risco de choques eléctricos e ferimentos graves durante a desmontagem e manutenção deste produto. Os profissionais destes serviços devem estar avisados deste facto e tomar os cuidados necessários.

Informació de Seguretat

- Aquest producte està dissenyat, comprovat i aprovat per tal d'acomplir les estrictes normes de seguretat globals amb la utililització de components específics de Lexmark. Les característiques de seguretat d'algunes peces pot ser que no sempre siguin òbvies. Lexmark no es responsabilitza de l'ús d'altres peces de recanvi.
- La informació pel manteniment d'aquest producte està orientada exclusivament a professionals i no està destinada a ningú que no ho sigui.
- El risc de xoc elèctric i de danys personals pot augmentar durant el procés de desmuntatge i de servei d'aquest producte. El personal professional ha d'estar-ne assabentat i prendre les mesures convenients.

안전 사항

- 본 제품에 관한 유지 보수 설명서는 전문 서비스 기술자 용으로 작성된 것이므로 비 전문가가 사용할 수 없습니다.
- 본제품을 해체하거나 정비할 경우 전기적인 충격을 받거나 상처를 입을 위험이 커집니다. 전문 서비스 기술자는 이 사실을 숙지하고 필요한 예방 조치를 취하도록 하십시오.
- 일부 부품의 안전성은 항상 보장되지 않습니다. 따라서, 교체 부품은 원래 부품과 같거나 동등한 특성을 가진 제품을 사용하여야합니다.

安全资讯

- 本产品的维护资讯仅供专业服务人员使用，而非针对一般使用者。
- 本产品在拆卸、维修的时候，遭受电击或人员受伤的危险性会增高，专业服务人员对这点必须有所了解，并采取必要的预防措施。
- 有些零件的安全功能可能不明显。因此，所替换零件的性能一定要与原有的零件一致。

Preface

This manual describes the Lexmark X73 Scan/Print/Copy (4402-001) and contains maintenance procedures for service personnel only. It is divided into the following chapters:

1. **General Information** contains a general description of the printer and the maintenance approach used to repair it. Special tools and test equipment are listed in this chapter, as well as general environmental and safety instructions.
2. **Diagnostic Information** contains an error indicator table, symptom tables, and service checks used to isolate failing field replaceable units (FRUs).
3. **Diagnostic Aids** contains tests and checks used to locate or repeat symptoms of scanner/printer/copier problems.
4. **Repair Information** provides instructions for making printer adjustments and removing and installing FRUs.
5. **Connector Locations** uses illustrations to identify the connector locations and test points on the printer.
6. **Preventive Maintenance** contains the lubrication specifications and recommendations to prevent problems.
7. **Parts Catalog** contains illustrations and part numbers for individual FRUs.

1. General Information

The Lexmark X73 machine is an electro-mechanical scanner, printer, and copier that creates characters and graphics by composing programmed patterns of ink dots using a printhead and liquid ink. The printhead uses small heater plates and nozzles to control ink flow and the formation of characters on the print media. The printhead assembly and ink supply are combined into a single-unit, print cartridge available as a customer replaceable supply item. Dual printheads provide color and true black printing without changing printheads. The number and size of inkjets or nozzles, in the printhead, determines the overall quality and capability of the printer. The black cartridge has a total of 208 nozzles and installs on the right. The color cartridge has a total of 192 nozzles and installs on the left. The printer is capable of printing in two directions from either cartridge.

Power Consumption

- <6 Watts - power off and power to the printer
- 8 Watts - Idle Mode (power on - not printing)
- 21 Watts - Printing (average)
- 31 Watts - Printing (peak)

Scanner Specifications

Scanner Type	Flatbed, CCD
Scan Modes	True Color: 48 Bit Internal (68.7 Billion Colors) 24 Bit External (16.7 Million Colors) Gray Mode: 12 Bits Internal (4,096 Shades of Gray) 8 Bits External (256 Shades of Gray) Text/Line Art: 1 Bit Per Pixel
Scan Method	One Pass Scanning
Scan Area	8.5 X 11.7 inches 216 X 292 mm
Scan Resolution	Optical: 600 dpi (H) X 1200 dpi (V) Interpolated: 9600 X 9600

Operator Panel



Press this button:	When you want to:
Setup	Adjust your copy and scan settings using the Scan & Copy Control Program on your computer.
Color Copy	Make a color copy.
Black Copy	Make a black and white copy.
Scan	Press the scan button after selecting a Scan To destination.
Scan To	Select a scan destination, such as To copy, To and e-mail, To an application, To a file, or To fax.
Scan To E-mail	Scan an image or document and send with an e-mail message.
Scan To Fax	Scan an image or document and send as a fax.
Paper Feed	Load or eject a sheet of paper from the printer.
Power	Turn the printer on or off.

Maintenance Approach

The diagnostic information in this manual leads you to the correct field replaceable unit (FRU) or part. Use the symptom index, service checks, and diagnostic aids to determine the symptom and repair the failure.

After you complete the repair, perform tests as needed to verify the repair.

Abbreviations

B/M	Bill of Material
CCD	Charged Coupled Device
EOF	End of Form
ESD	Electrostatic Discharge
FPC	Flat Printhead Cable
FRU	Field Replaceable Unit
HVPS	High Voltage Power Supply
LVPS	Low Voltage Power Supply
OEM	Original Equipment Manufacturer
V ac	Volts alternating current
V dc	Volts direct current
ZIF	Zero Insertion Force

2. Diagnostic Information

Start

Use the symptom tables, service checks, and diagnostic aids in chapter three, to determine the printer failure.

Power-On Self Test (POST) Sequence

Press the power button to turn machine on.

- Power light turns on.
- The paper feed motor runs then stops.
- Status light stays on for a second and turns off.
- The carrier moves to the left then returns to the right stopping at the maintenance station.
- Power light stays on.

If your printer completes POST with no errors, go to the **“Symptom Tables” on page 2-3**, locate the symptom and take the indicated action.

If your printer does not complete POST, locate the symptom in the following table and take the indicated action.

POST Symptom Table

Symptom	Action
No Power or Status lights and no motors run.	Go to the “Power Service Check” on page 2-14 . If okay, go to the “Operator Panel Problems” on page 2-3 .
Paper feed gears do not turn	Go to the “Paper Feed Service Check” on page 2-11 .
Carrier does not move	Go to the “Carrier Transport Service Check” on page 2-6 .
Carrier slams side frame	Go to the “Carrier Transport Service Check” on page 2-6 .
CCD does not move	Go to the “Gear Train Assembly Service Check” on page 2-9 .
CCD lamp does not turn on	Go to the “CCD Module Assembly Service Check” on page 2-8 .

Symptom Tables

Locate the symptom in the following tables and take the appropriate action.

Carrier Transport Problems

Symptom	Action
<ul style="list-style-type: none"> • No carrier movement • Slow carrier movement • Carrier stops • Carrier slams side frame 	Go to the “Carrier Transport Service Check” on page 2-6.

Maintenance Station Problems

Symptom	Action
Maintenance station: <ul style="list-style-type: none"> • Fails to cap the printheads • Fails to clean the printheads 	Go to the “Maintenance Station Service Check” on page 2-10.

Operator Panel Problems

Symptom	Action
<ul style="list-style-type: none"> • Buttons do not work • Power or status lights do not work 	<p>Check operator panel cable connection at J6 on the system board. Then run the “Power-On Self Test (POST) Sequence” on page 2-1. If operator panel fails, replace the operator panel assembly. If the problem still exists, replace the system board. Go to the “System Board Removal” on page 4-12.</p> <p>Note: If any buttons or lights fail, check connection J6. If the problem remains, replace the operator panel assembly. Go to the “Operator Panel Removal” on page 4-4.</p>

Printer Communication Table

Symptom	Action
<ul style="list-style-type: none"> • Not able to print Test Page 	<p>Check the USB cable and system board cable connections. If okay, replace system board. Go to the “System Board Removal” on page 4-12.</p>

Scanner Problems

Symptom	Action
<ul style="list-style-type: none"> • CCD does not move • Lamp does not light 	<p>Go to the “CCD Module Assembly Service Check” on page 2-8.</p> <p>Go to the “Gear Train Assembly Service Check” on page 2-9.</p>
<ul style="list-style-type: none"> • Scanned images are faded, or colors are dull, blurry or fuzzy. Images are slanted or crooked and the straight lines in the image appear to be jagged or uneven. • Blank copies. 	<p>Go to the “Scan/Copy Quality Service Check” on page 2-17.</p>

Paper Feed Problems

Symptom	Action
<ul style="list-style-type: none"> • Fails to pick paper • Picks more than one sheet of paper • Picks paper but fails to feed • Paper jams • Paper fails to exit • Noisy paper feed 	Go to the “Paper Feed Service Check” on page 2-11.
Envelopes fail to feed	Go to the “Paper Feed Service Check” on page 2-11.
Paper skews	Go to the “Paper Path Service Check” on page 2-13.

Power Problems

Symptom	Action
No power in machine, motors do not operate	Go to the “Power Service Check” on page 2-14.

Print Quality Problems

Symptom	Action
<ul style="list-style-type: none"> • Voids in characters • Light print • Prints off the page • Fuzzy print • Carrier moves but no print • Printhead dries prematurely • Colors print incorrectly • Vertical alignment off 	Go to the “Print Quality Service Check” on page 2-15.
<ul style="list-style-type: none"> • Ink smearing • Vertical streaks on paper • Print lines crowded 	Go to the “Paper Feed Service Check” on page 2-11.

Service Checks

Carrier Transport Service Check

	FRU	Action
1	System Board Carrier Transport Motor	Check the transport carrier motor connector J4. If connected, check for approximately 28 volts on pins 1 and 2 or at the wire connections located on the rear of the transport carrier motor. If voltage is incorrect, replace the system board. If voltage is correct, check the motor for shorts.
2	Carrier Transport Motor	<p>Check the motor for binds, or loose motor pulley.</p> <p>A noisy or chattering motor or a motor that fails to turn can be caused by:</p> <ul style="list-style-type: none"> • An open or short in the motor. • An open or short in the motor driver on the system board. • A bind in the carrier transport mechanism. <p>With the carrier transport motor cable (J4) disconnected from the system board, check for 0 to 10 ohms between the following pins on the motor:</p> <p>J4-1 and J4-2</p> <p>If the readings are incorrect, replace the print engine. Go to the “Print Engine Removal” on page 4-11.</p>
3	Carrier Guide Rod	<p>Clean the carrier rod.</p> <p>Note: Lubricate the rod and the carrier rod bearing surfaces with grease P/N 99A0394.</p>

	FRU	Action
4	Encoder Strip Carrier with PCB Assembly	<p>Check the encoder strip for proper installation. Also, check it for wear, dirt and grease.</p> <p>Be sure all printhead connectors are fully seated. Check the cables for damage.</p> <p>If the encoder strip and all connections are okay, but the carrier still slams the side frame, replace the print engine. Go to the “Print Engine Removal” on page 4-11.</p>
5	Carrier Transport Belt Idler Pulley Parts Carrier Frame	<p>Check for worn, loose or broken parts. Check for obstructions blocking carrier movement.</p> <p>Check the carrier belt idler pulley mounting screw. Loosen the screw and allow the tension spring to take up any slack in the belt. Tighten the screw. If the pulley mounting bracket has reached the stop, replace the belt. Go to the “Belt/Idler Pulley Assembly (Print Engine) Removal” on page 4-14.</p> <p>Lubricate carrier to carrier frame engagement with grease P/N 99A0394.</p>
6	Printhead Carrier Assembly	<p>Disconnect the printer and check the carrier printhead connector (J2). If the connection is good, remove the printhead carrier and check the cable connection to the home sensor board. If the problem remains, replace the system board. Go to the “System Board Removal” on page 4-12.</p>
7	Maintenance Station	<p>A problem with the maintenance station can cause carrier movement problems at the right margin. Go to the “Maintenance Station Removal” on page 4-14.</p>
8	Access Cover Sensor	<p>If the carrier does not move toward the cartridge load position when the access cover is opened, verify that power is on. If the carrier still does not move, check connector J9 pin 1 for approximately 5 volts, with the cover closed. If the voltage is correct, replace the sensor. Go to the “Access Cover Sensor Removal” on page 4-6. If the voltage is incorrect, replace the system board. Go to the “System Board Removal” on page 4-12.</p>

CCD Module Assembly Service Check

- The CCD (charged coupled device) Module will not move during POST Test.
- The CCD lamp does not come on when CCD module assembly moves.

	FRU	Action
1	CCD Module Assembly	<p>If CCD module will not move, go to the “Gear Train Assembly Service Check” on page 2-9.</p> <p>Note: If the printer is not connected to the PC and Lexmark Scan and Copy Control program is not opened, the CCP lamp will not come on.</p> <p>If lamp does not come on as CCD module assembly is scanning or moving, check connector (J7) on the system board. If connected and the lamp still does not work, replace the CCD module assembly. If the lamp does not correct the problem after the CCD replacement, replace the system board. See “System Board Removal” on page 4-12 for more information.</p> <p>To unlock scanner, press the red lever down. The lever is located by the USB plug on the rear of the machine.</p> <p>Note: Unlock scanner before use.</p>

Gear Train Assembly Service Check

CCD will not move or scan.

	FRU	Action
1	Gear Train Assembly	<p>Disconnect J5 and check the reading at pin 1 and 3 for approximately 225.5 ohms. If the reading is incorrect, replace the gear train assembly. Go to the “Gear Train Assembly Removal” on page 4-6. If the reading is correct, check at pins 1 through 6 for approximately 28 volts, with the machine turned on. If the voltage is incorrect, replace the system board. Go to the “System Board Removal” on page 4-12.</p> <p>Note: Ensure scanner is unlocked.</p>
2	Scanner Belt	<p>Check the belt for proper installation. If the belt is damaged, replace. Go to the “Belt/Idler Pulley Assembly (Print Engine) Removal” on page 4-14.</p> <p>Note: If not properly installed, the belt will slip.</p>

Maintenance Station Service Check

The maintenance station has three functions:

1. Wipes the printhead nozzles to clean them of dirt.
2. Provides a place for printheads to fire all nozzles, keeping them clear prior to printing.
3. Seals the printhead when it is not being used to prevent the nozzles from drying.

	FRU	Action
1	Maintenance Station Assembly	<p>As the carrier moves to the right over the maintenance station, a slot on the bottom of the carrier engages a tab on the sled of the maintenance station causing the cap to rise and seal the printhead. Carrier movement to the left uncaps the printhead. The wiper cleans the printhead nozzles as the carrier leaves the maintenance station. The wiper cleans the printhead only when the carrier is moving to the left. There should be no wiping action of the printhead nozzles when the carrier is moving to the right. After the cleaning operation is complete, a tab on the maintenance station engages a tab on the carrier, causing the wiper to lower.</p> <p>Check the maintenance station for worn or broken parts. Replace if needed. Go to the “Maintenance Station Removal” on page 4-14.</p> <p>Worn wipers cause degraded print quality just after a maintenance cleaning. Check for loose or worn wipers.</p> <p>Worn caps cause the printhead nozzles to dry and clog. Check for loose or worn caps.</p>

Paper Feed Service Check

If your machine does not have paper jam problems, continue with the service check. If your machine does have a paper jam problem, examine it for the following before you begin the service check:

- Check the entire paper path for obstructions.
- Be sure there is not too much paper in the sheet feeder.
- Be sure the correct type of paper is being used.
- Check for static in the paper.

	FRU	Action
1	System Board	Run the “Power-On Self Test (POST) Sequence” on page 2-1 . Replace parts as needed. To check the paper feed motor, disconnect the paper feed connector J3 and check for approximately 5 ohms between pins 3 and 4. If the reading is incorrect, replace the print engine. Go to the “Print Engine Removal” on page 4-11 . If the reading is correct, replace the system board. Go to the “System Board Removal” on page 4-12 .

	FRU	Action
2	Paper Feed Motor	<p>A noisy or chattering motor or a motor that fails to turn, can be caused by:</p> <ul style="list-style-type: none"> • An open or short in the motor • An open or short in the motor driver on the system board • A bind in the paper feed mechanism <p>With the paper feed motor cable J3 disconnected from the system board, check for approximately 5 ohms between the following pins on the motor:</p> <p>Pin 3 to Pin 4</p> <p>If the readings are incorrect, replace the print engine. Go to the “Print Engine Removal” on page 4-11.</p> <p>Although the paper feeds in a forward direction only, the paper feed motor turns in two directions. If the paper feed motor turns in one direction only, replace the system board. Go to the “System Board Removal” on page 4-12.</p> <p>Binds in the paper feed motor or gear train can cause intermittent false paper jam errors. Remove the paper feed motor and check the shaft for binds. Also check for a loose or worn motor gear.</p>
3	Auto Sheet Feeder Assembly	Check the pick roller for wear.
4	Mid Frame Assembly	<p>Check the following for wear:</p> <ul style="list-style-type: none"> • Small Feed rollers • Large Feed roller • Exit roller • Star rollers <p>If any rollers need to be replaced, go to the “Print Engine Removal” on page 4-11 and replace the print engine.</p>
5	End-of-Forms Flag and Spring	Check for binds or damage.

Paper Path Service Check

Examine the machine for the following before you begin this service check:

- Check the entire paper path for obstructions.
- Be sure the correct type of paper is being used.
- Be sure the printer is installed on a flat surface.

	FRU	Action
1	Large and Small Feed Rollers	Check for wear and binds.
2	Small Feed Roller Springs	Check for damage.
3	Auto Sheet Feeder Assembly	Check the pick roller for wear.
4	Mid Frame Asm	Check the following for wear: <ul style="list-style-type: none"> • Exit roller • Star rollers
5	End-of-Forms Flag	Check for binds or damage.

Power Service Check

	FRU	Action
1	External Power Supply	Plug the external power supply into an outlet. Check for + 30 V dc. If voltage is incorrect, replace the power supply.
2	Printhead Cable Paper Feed Motor Carrier Transport Motor Operator Panel	Unplug the printer. Disconnect the printhead cable and plug in the printer. Look for a symptom change. Check the failing part for shorts and replace as necessary. Repeat this procedure for the carrier transport motor, paper feed motor, and operator panel.
3	System Board	If the symptom has not changed, replace the system board. Go to the “System Board Removal” on page 4-12.

Print Quality Service Check

	FRU / Function	Action
1	Printhead Cartridge	Be sure the machine contains good print cartridges.
2	Color Printhead Cartridge Cross Contamination	<p>Cross contamination of color inks results in incorrect colors printed, as when green prints for yellow, (when yellow and blue are mixed in the printhead cartridge). This problem resolves quickly as the printhead cartridge is used.</p> <p>If cross contamination occurs, check the following:</p> <ul style="list-style-type: none"> • The maintenance station wiper for damage. • The printhead nozzle plate was resealed with tape.
3	Printhead Carrier Assembly	<p>Reseat the printhead cable in the system board and check the following parts for wear or damage:</p> <ul style="list-style-type: none"> • Printhead Cartridge Latch • Latch Spring • Carrier
4	System Board Printhead Carrier Assembly	<p>Perform the “Test Page” on page 3-1. Look for a break in the diagonal line of the nozzle test pattern. A broken line indicates one or more print nozzles are not working. Run the test again to verify the failure.</p> <p>Check the gold-plated contacts on the end of the printhead carrier cable for dirt, wear, and damage. Use only a clean dry cloth to clean the contacts.</p> <p>If the symptom remains, replace the system board. Go to the “System Board Removal” on page 4-12.</p>
5	Maintenance Station	<p>Intermittent nozzle failures can be caused by worn parts in the maintenance station. Go to the “Maintenance Station Removal” on page 4-14, and then return to this check.</p>

	FRU / Function	Action
6	Paper Feed	<p>Ink smudging and smearing can be caused by paper problems or problems in the paper feed area.</p> <p>Check the following:</p> <ul style="list-style-type: none"> • Correct type of paper is being used. Also check the paper for curl or wrinkles. • Feed rollers for wear, dirt, or looseness. • Gears for wear or binds. • Paper path for obstructions.
7	Carrier Transport	<p>Blurred print and voids can be caused by problems in the carrier transport area. Check the following:</p> <ul style="list-style-type: none"> • Carrier transport belt for wear. • Carrier guide rod for wear or dirt. If dirty, clean and lubricate. • Carrier to carrier frame engagement should be lubricated with grease P/N 99A0394. • Idler pulley parts for wear, damage, or looseness.
8	Alignment	<p>Uneven vertical lines can be adjusted by performing the printhead alignment adjustments. The user is directed, through the Printer Control program, to perform the printhead alignment adjustments, when replacing a printhead cartridge.</p>

Scan/Copy Quality Service Check

	FRU / Function	Action
1	Scanned images are faded, or colors are dull, blurry or fuzzy. Images are slanted or crooked and the straight lines in the image appear to be jagged or uneven.	<p>Check the lighter/darker settings to see if it is correct. There are two ways to make the adjustment:</p> <p>From the Lexmark Scan and Copy Control program.</p> <p>Check to see if there is any dust, debris on the glass. This may cause a poor image.</p> <p>Check the press plate on the scan lid for any dust or debris.</p>
2	Blank copies.	<p>If there are blank copies, make sure the original document is facing down on the scanner bed.</p> <p>Check the print cartridges to see if they need to be cleaned or replaced.</p> <p>Check the paper type and copy quality settings on the operator panel or Lexmark Scan and Copy Control program.</p>

4402-001

3. Diagnostic Aids

Test Page

This test prints the test page.

To run a complete test page of black and color patterns, be sure the printhead cartridges are in good condition.

To enter the test:

1. Open the access cover.
2. Install a known good black print cartridge in the right side of the carrier and a good color print cartridge in the left side.
3. Close the access cover.
4. Install paper in the sheet feeder.
5. Press and hold the paper feed button while pressing the power button and releasing it.
6. Paper feeds into the printer.
7. The test page prints.

The test page consists of three color bars, nozzle purge pattern, black purge pattern, black nozzle purge pattern and heater checks.

Note: To stop test page, press the power button again.

The test page prints three color bars, nozzle purge pattern, black purge pattern, black nozzle purge pattern and heater checks. The purge pattern is used to clear all printhead nozzles. The nozzle test pattern prints all nozzles on a diagonal line. There should be no breaks in the nozzle test pattern. A break in the pattern indicates one or more nozzles are not working.

If a print quality problem exists, see [“Print Quality Service Check” on page 2-15](#).

4402-001

4. Repair Information

This chapter explains how to make adjustments to the printer and how to remove defective parts.

Note: Read the following before handling electronic parts.

Handling ESD-Sensitive Parts

Many electronic products use parts that are known to be sensitive to electrostatic discharge (ESD). To prevent damage to ESD-sensitive parts, follow the instructions below in addition to all the usual precautions, such as turning off power before removing system board:

- Keep the ESD-sensitive part in its original shipping container (a special “ESD bag”) until you are ready to install the part into the machine.
- Make the least-possible movements with your body to prevent an increase of static electricity from clothing fibers, carpets, and furniture.
- Put the ESD wrist strap on your wrist. Connect the wrist band to the system ground point. This discharges any static electricity in your body to the machine.
- Hold the ESD-sensitive part by its edge connector shroud (cover); do not touch its pins. If you are removing a pluggable module, use the correct tool.
- Do not place the ESD-sensitive part on the machine cover or on a metal table; if you need to put down the ESD-sensitive part for any reason, first put it into its special bag.
- Machine covers and metal tables are electrical grounds. They increase the risk of damage because they make a discharge path from your body through the ESD-sensitive part. (Large metal objects can be discharge paths without being grounded.)
- Prevent ESD-sensitive parts from being accidentally touched by other personnel. Install machine covers when you are not working on the machine, and do not put unprotected ESD-sensitive parts on a table.
- If possible, keep all ESD-sensitive parts in a grounded metal cabinet (case).
- Be extra careful in working with ESD-sensitive parts when cold weather heating is used because low humidity increases static electricity.

Adjustments

The user is directed, in the Printer Control program, to perform the printhead alignment adjustments after replacing a print cartridge.

Removal Procedures

The following procedures are arranged according to the name of the printer part discussed.

CAUTION: Unplug the power cord before removing any parts.

Releasing Plastic Latches

Many of the parts are held in place with plastic latches. The latches break easily; release them carefully. To remove such parts, press the hook end of the latch away from the part to which it is latched.

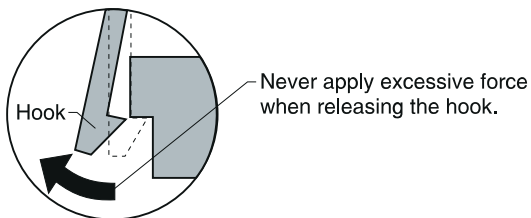

Scanner Lid Assembly Removal

1. Open the lid.
2. Lift and remove.

Rear Cover Removal

1. Remove two screws **[A]** from the rear cover.
2. Depress two latches **[B]** on the bottom of the rear cover.
3. Lift the rear cover and remove

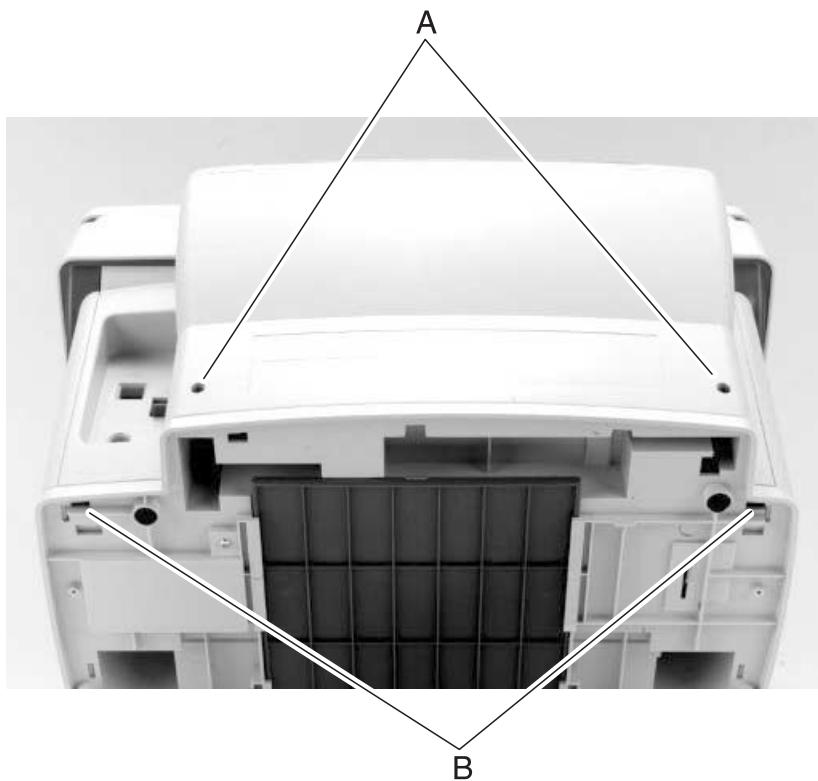

Operator Panel Removal

1. Remove the scanner lid.
2. Remove the rear cover.
3. Disconnect the operator panel cable from the system board.
4. Depress two latches on the left side of the operator panel.
5. Lift the operator panel and remove.

Top Housing Assembly Removal

1. Remove the scanner lid.
2. Remove the rear cover.
3. Disconnect the operator panel cable from the system board.
4. Remove the operator panel.
5. Remove two screws from the top housing.
6. Lift the right side of the housing.
7. Remove the top housing assembly.

Paper Support Removal

1. Open the paper support.
2. Depress the paper support at the hinge.
3. Remove the paper support.

CCD Module Assembly Removal

1. Remove the rear cover.
2. Disconnect the CCD cable from the system board.
3. Remove the top housing assembly.
4. Depress the shaft retainer **[A]**.
5. Lift and remove the shaft.
6. Remove the belt from pulleys.
7. Lift and remove the CCD module.



Gear Train Assembly Removal

1. Remove the CCD module assembly.
2. Disconnect the gear train assembly cable from the system board.
3. Remove two screws **[A]**.
4. Lift and remove the gear train assembly.

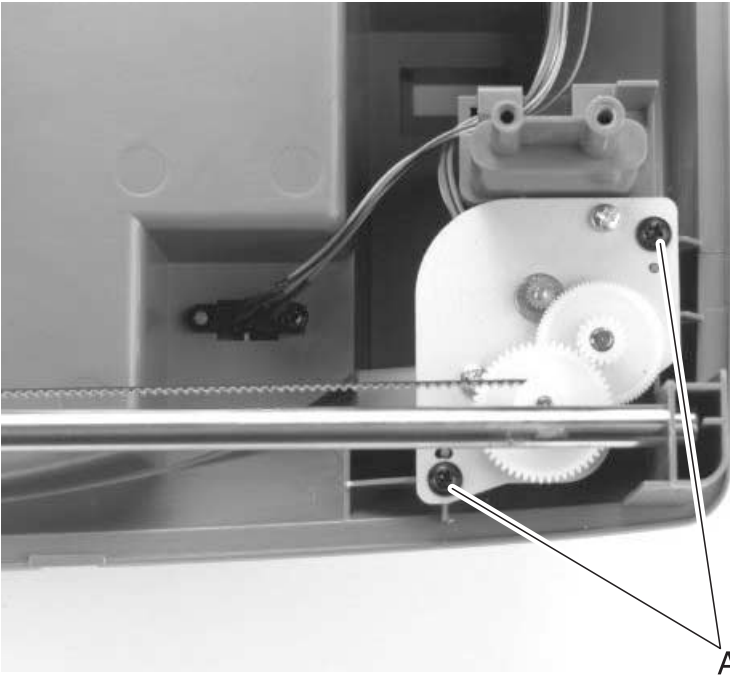

Access Cover Sensor Removal

1. Remove the top housing assembly.
2. Disconnect the access cover sensor cable (J9) from the system board.
3. Remove the sensor screw **[B]**.
4. Remove the sensor. Note routing of cables.

4402-001

Right Cover Removal

1. Remove the rear cover.
2. Depress two latches **[A]**.
3. Remove the right cover.

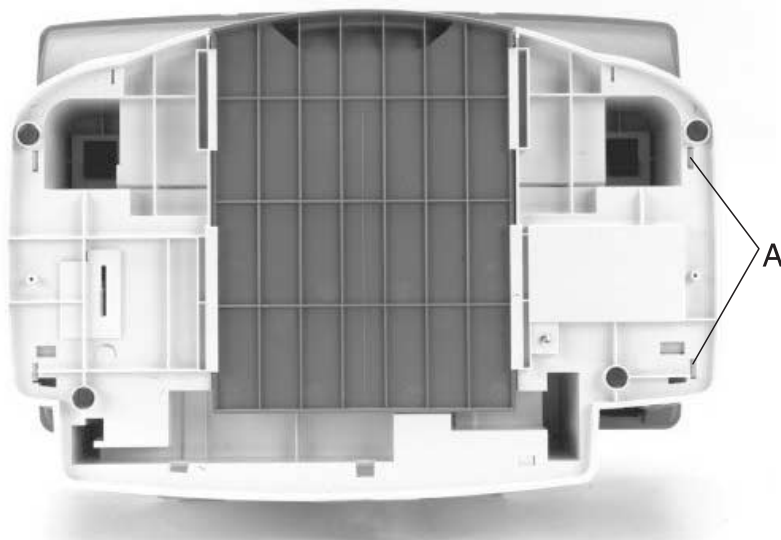

Access Cover Removal

1. Remove the rear cover.
2. Remove the right cover.
3. Depress the access cover hinge.
4. Remove the access cover.

Left Cover Removal

1. Remove the rear cover.
2. Depress two latches [A].
3. Remove the left cover.

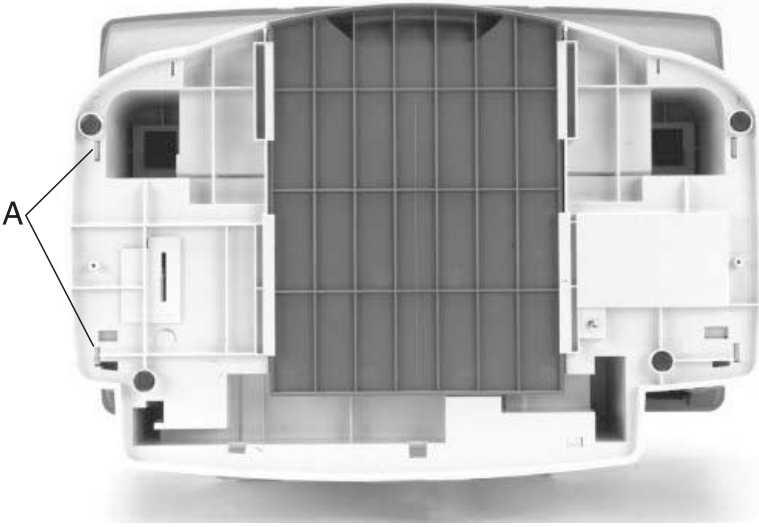

Middle Frame Removal

1. Remove the scanner lid assembly.
2. Remove the rear cover.
3. Remove the top housing assembly.
4. Disconnect the operator panel and CCD cables from the system board.
5. Remove left and right covers.
6. Remove the operator panel assembly.
7. Remove the two screws [A].

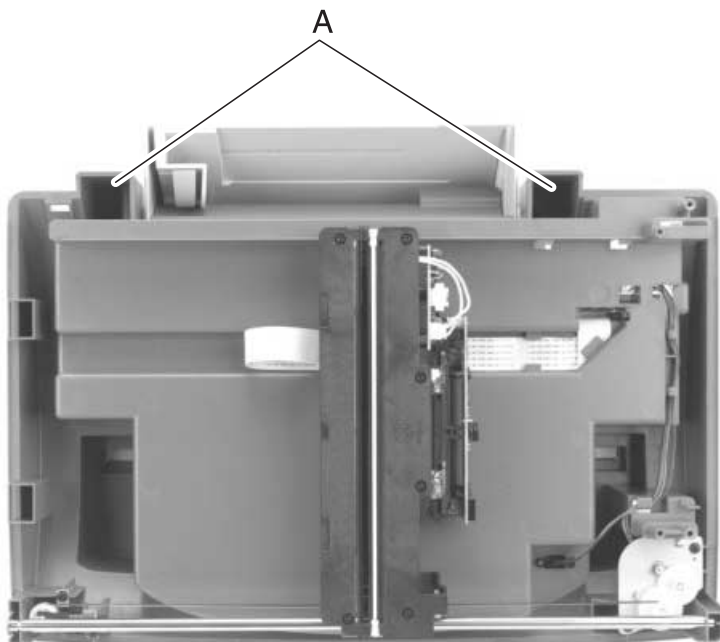

4402-001

8. Depress the two clips **[B]** and slide the middle frame forward to remove.

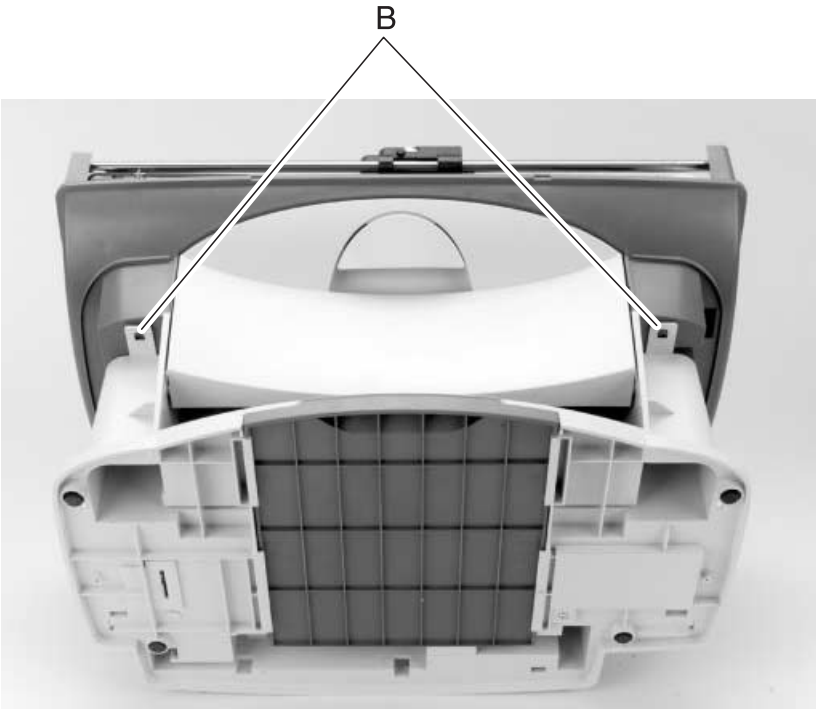

Print Engine Removal

1. Remove the rear cover.
2. Remove the top housing assembly.
3. Remove the left cover.
4. Remove the right cover.
5. Remove the middle frame.
6. Move carrier to the center.
7. Remove three screws **[B]**.

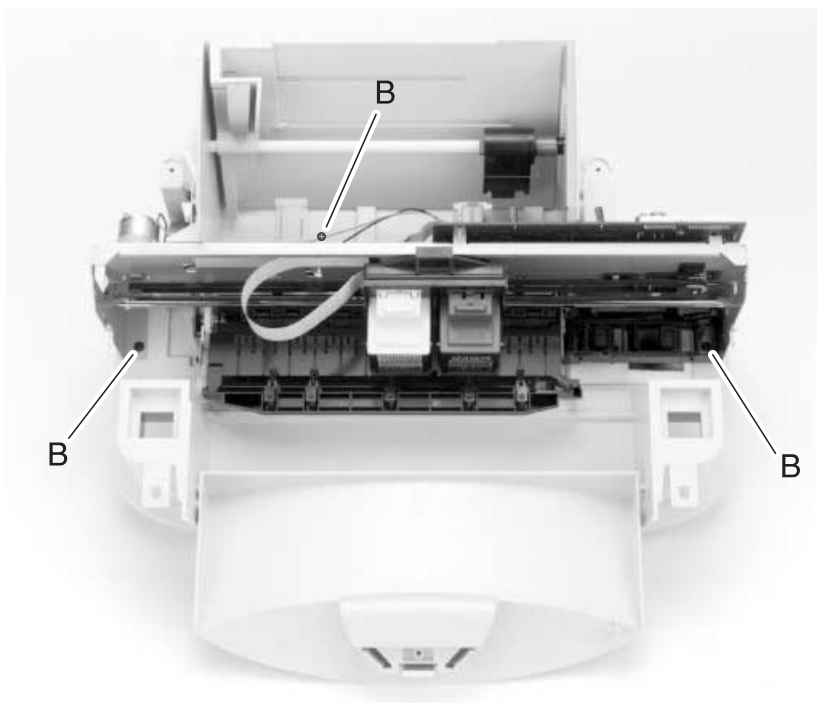

8. Slide the print engine forward and remove.

ASF Module Removal

1. Remove the print engine.
2. Remove three screws [A].
3. Remove the ASF module.

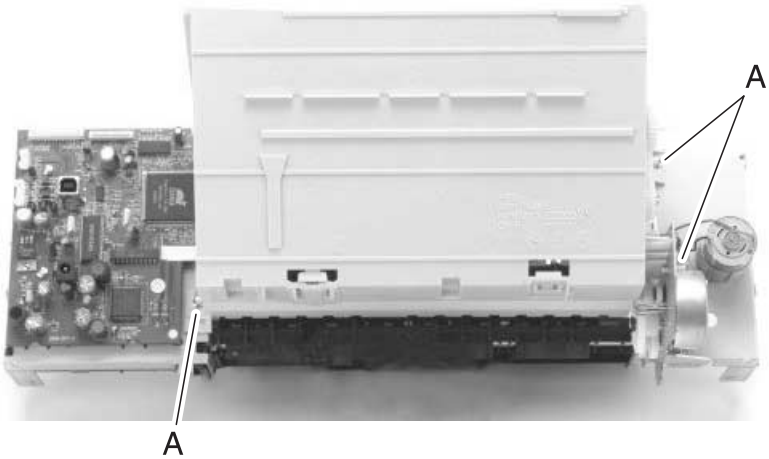

System Board Removal

1. Remove the print engine.
2. Remove the ASF module.
3. Disconnect the transport and paper feed motor cables from the system board.
4. Remove the four screws.
5. Remove the system board.

WARNING: When removing the system board, use care not to damage the EOF flag.

Carrier Removal

1. Remove the rear cover.
2. Remove the top housing Assembly.
3. Remove the left and right covers.
4. Disconnect the carrier cable from the system board.
5. Loosen the set screw on the carrier belt tensioner.
6. Depress the belt tensioner and remove the belt from the transport carrier motor gear.
7. Remove both retainer clips from the carrier shaft.
8. Remove the shaft and carrier.

Note:

- Keep dirt and grease off of the encoder strip.
- Observe orientation of the encoder strip to the sensor, located on the rear of the carrier.
- Be careful not to damage the encoder strip when reinstalling the carrier.

Encoder Strip Removal

1. Remove the carrier assembly.
2. Depress the encoder strip clip.
3. Remove the encoder strip.

Maintenance Station Removal

1. Remove the middle frame assembly.
2. Remove the print engine.
3. Depress the two clips **[A]**.
4. Remove the maintenance station.

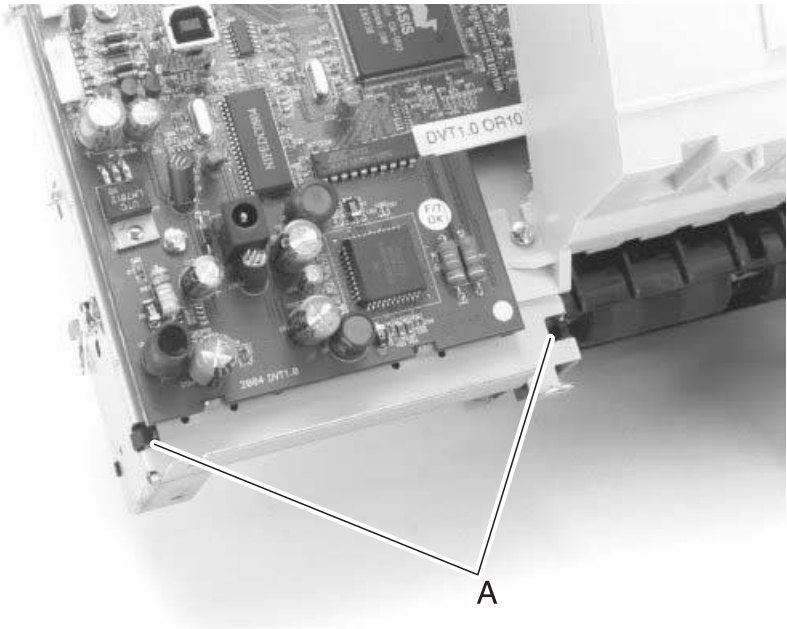

Belt/Idler Pulley Assembly (Print Engine) Removal

1. Remove the middle frame.
2. Slide the carrier to the left.
3. Loosen the belt tensioner adjuster screw.
4. Depress the belt tensioner and remove the belt from the pulley.
5. Depress the latch.
6. Slide the belt tensioner to the right and remove.

5. Connector Locations

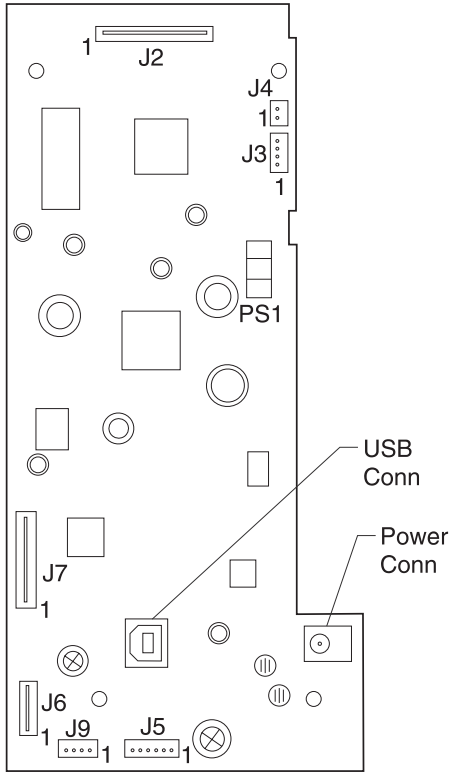

Units	Description
J2	Printhead Cable
J3	Paper Feed Motor
J4	Carrier Transport Motor
J5	Scanner Motor
J6	Operator Panel
J7	CCD Module
J9	Cover Sensor
PS1	End-of-Forms Sensor

4402-001

6. Preventive Maintenance

This chapter contains the lubrication specifications. Follow these recommendations to prevent problems and maintain optimum performance.

Lubrication Specifications

Lubricate only when parts are replaced or as needed, not on a scheduled basis. Use grease P/N 99A0394 to lubricate the following:

- All gear mounting studs.
- The left and right ends of the large feed roller at the side frames.
- The carrier to carrier frame engagement.
- The carrier guide rod, and carrier guide rod bearings.

WARNING: Keep the grease from coming into contact with any electrical components, may cause printer damage or failure. Do not lubricate the scanner rod or bearing after replacing.

4402-001

7. Parts Catalog

How to Use This Parts Catalog

- **SIMILAR ASSEMBLIES:** If two assemblies contain a majority of identical parts, they are shown on the same list. Common parts are shown by one index number. Parts peculiar to one or the other of the assemblies are listed separately and identified by description.
- **NS:** (Not Shown) in the Asm-Index column indicates that the part is procurable but is not pictured in the illustration.
- **PP:** in the parts description column indicates the part is available in the listed parts packet.
- **NA:** Not available as a FRU.

Assembly 1: Covers

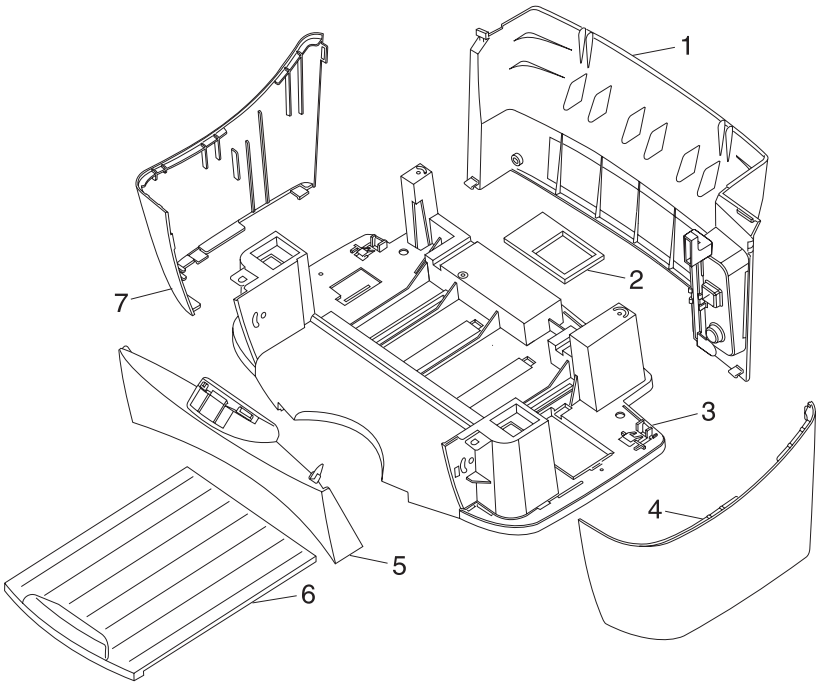

Assembly 1: Covers

Asm-Index	Part Number	Units	Description
1-1	12G6141	1	Cover Assembly, Rear
-2	12G6140	1	Felt Pad Assembly
-3	12G6138	1	Base Assembly
-4	12G6135	1	Cover, Right
-5	12G6133	1	Cover, Access with Latch
-6	12G6175	1	Paper Exit Tray
-7	12G6134	1	Cover, Left
NS	12G6156	4	Screws (PP)
NS	7366857	1	Plain package B/M includes: Carton, Cushion Set, Sealing Tape

Assembly 1 (cont.): Covers

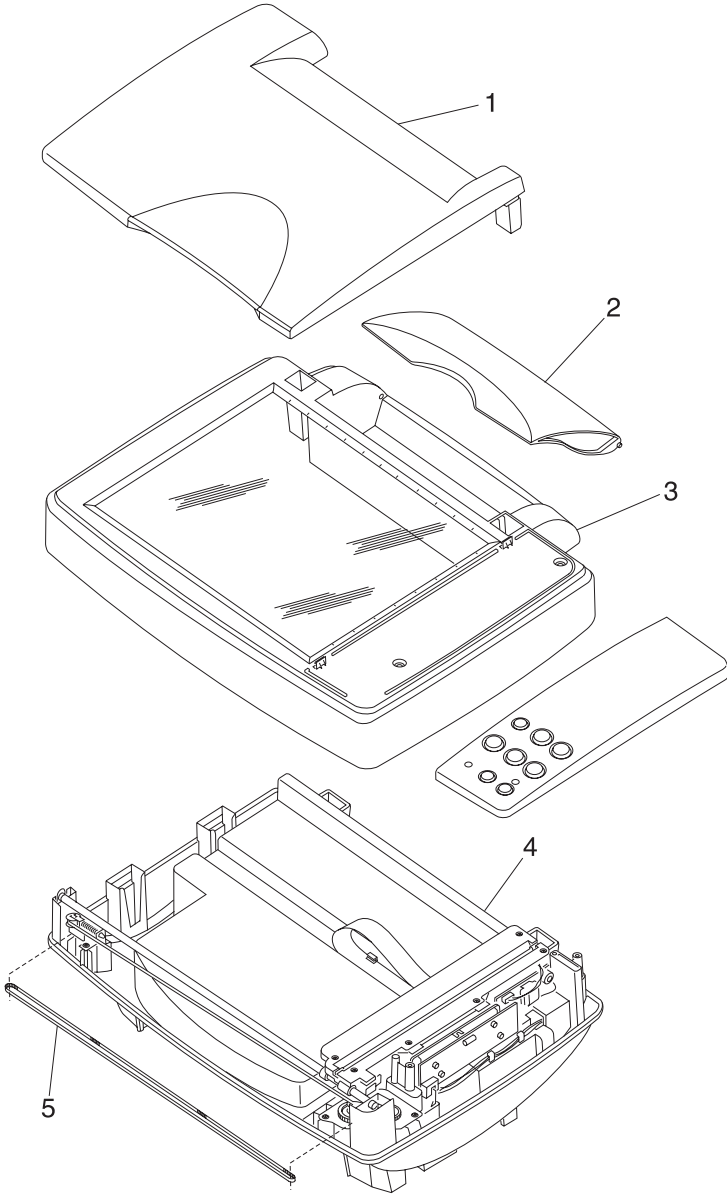

Assembly 1 (cont.): Covers

Assembly 1: Covers

Asm-Index	Part Number	Units	Description
1-1	12G6171	1	Scanner Lid Assembly
-2	12G6174	1	Paper Support ASF
-3	12G6126	1	Top Housing Assembly
-4	12G6122	1	Middle Frame Assembly
-5	12G6150	1	Belt, Scanner

Assembly 2: Paper Feed, Frame and Carrier Transport

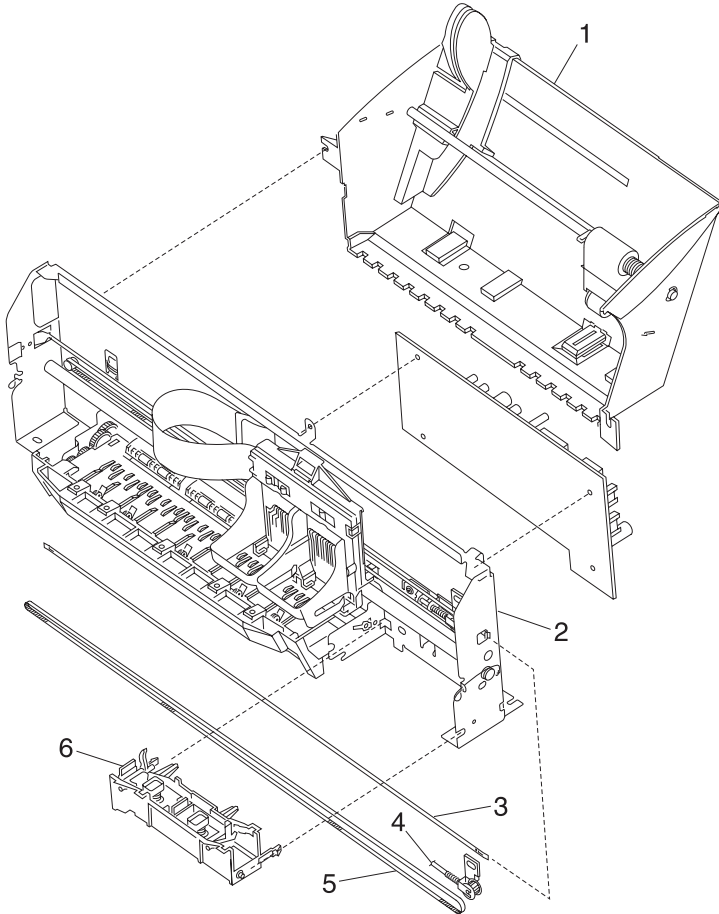

Assembly 2: Paper Feed, Frame and Carrier Transport

Asm-Index	Part Number	Units	Description
2-1	12G6121	1	ASF Module
-2	12G6120	1	Printing Engine
-3	12G6151	1	Encoder Strip with Clip
-4	12G6123	1	Idler Pulley Assembly
-5	12G6149	1	Belt, Carrier
-6	12G6154	1	Maintenance Station Assembly
NS	12G6153	1	EOF Flag with Spring

Assembly 3: Electronics

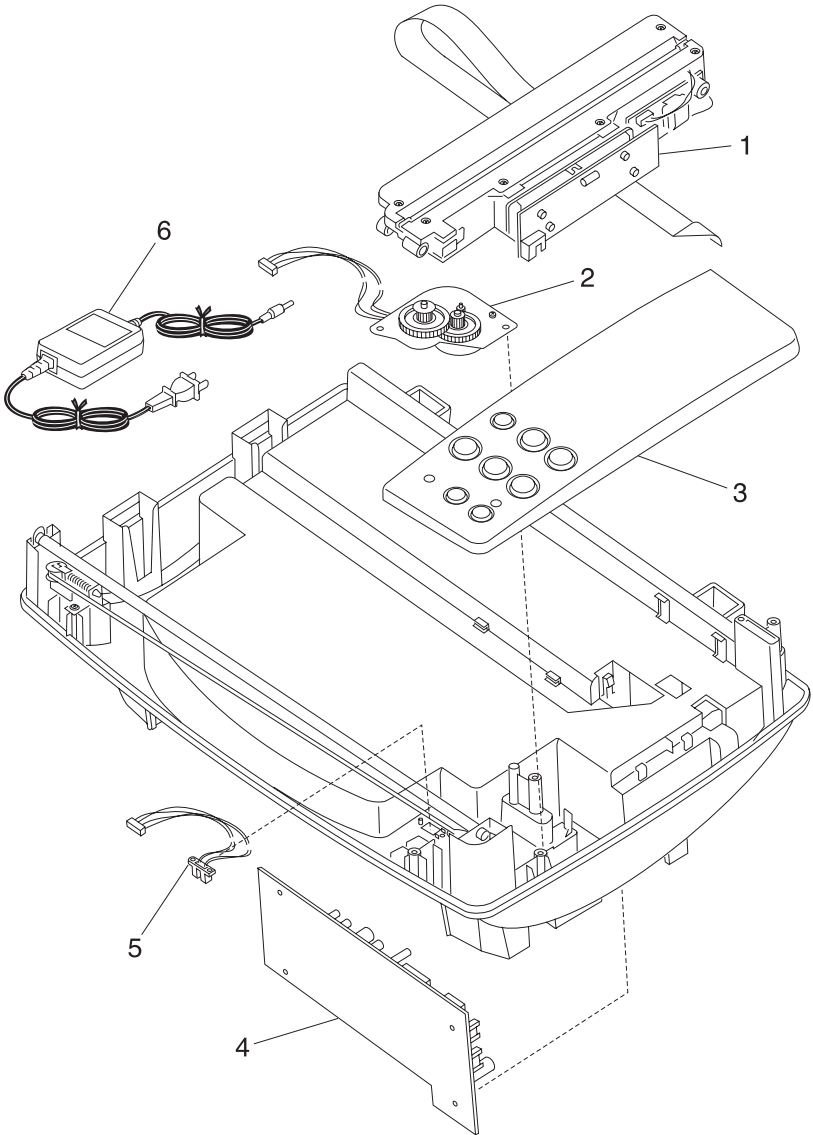

Assembly 3: Electronics

3-1	12G6177	1	CCD Module Assembly with Cable
NS	12G6124	1	CCD Module Assembly
NS	12G6176	1	CCD Cable
-2	12G6125	1	Gear Train Assembly
-3	12G6172	1	Operator Panel Assembly
NS	12G6173	1	Operator Panel Overlays
-4	12G6170	1	Board, System
-5	12G6137	1	Sensor, Access Cover
-6	12G6128	1	Power Supply (LV) 100-127
NS	12G6157	1	Power Supply (HV) 220-240
NS	12G6158	1	Power Supply – Japan 100V

4402-001

Index

A

- Abbreviations 1-4
- Adjustments 4-2

B

- Black Copy button 1-3
- Button
 - Black Copy 1-3
 - Color Copy 1-3
 - Paper Feed 1-3
 - Power 1-3
 - Scan 1-3
 - Scan To 1-3
 - Scan To E-mail 1-3
 - Scan To Fax 1-3
 - Setup 1-3

C

- Color Copy button 1-3
- Connector Locations 5-1

E

- ESD-Sensitive Parts 4-1

L

- Lubrication Specifications 6-1

M

- Maintenance Approach 1-4

O

- Operator Panel 1-3

P

- Paper Feed button 1-3
- Parts Catalog 7-1
 - Carrier Transport 7-6
 - Covers 7-2
 - Electronics 7-8
 - Frame 7-6
 - Paper Feed 7-6

- Plastic Latches 4-2
- Power button 1-3
- Power Consumption 1-1, 1-3
- Power-On Self Test
 - Sequence 2-1
 - Symptom Table 2-2
- Problems
 - Carrier Transport 2-3
 - Maintenance Station 2-3
 - Operator Panel 2-3
 - Paper Feed 2-5
 - Power 2-5
 - Print Quality 2-5
 - Scanner 2-4

R

- Removals
 - Access Cover 4-7
 - Access Cover Sensor 4-6
 - ASF Module 4-12
 - Belt/Idler Pulley Assembly 4-14
 - Carrier 4-13
 - CCD Module Assembly 4-5
 - Encoder Strip 4-13
 - Gear Train Assembly 4-6
 - Left Cover 4-8
 - Maintenance Station 4-14
 - Middle Frame 4-9
 - Operator Panel 4-4
 - Paper Support 4-4
 - Print Engine 4-11
 - Rear Cover 4-3
 - Right Cover 4-7
 - Scanner Lid Assembly 4-3
 - System Board 4-12
 - Top Housing Assembly 4-4

S

Safety Information [1-v](#)
Scan button [1-3](#)
Scan To button [1-3](#)
Scan To E-mail button [1-3](#)
Scan To Fax button [1-3](#)
Service Checks
 Carrier Transport [2-6](#)
 CCD Module Assembly [2-8](#)
 Gear Train Assembly [2-9](#)
 Paper Feed [2-11](#)
 Paper Path [2-13](#)
 Power [2-14](#)
 Print Quality [2-15](#)
Setup Button [1-3](#)
Specifications
 Scanner [1-2](#)
Start [2-1](#)
Symptom Table (POST) [2-2](#)
Symptom Tables [2-3](#)

T

Test Page [3-1](#)

Part Numbers

12G6120 [7-7](#)
12G6121 [7-7](#)
12G6122 [7-5](#)
12G6123 [7-7](#)
12G6124 [7-9](#)
12G6125 [7-9](#)
12G6126 [7-5](#)
12G6128 [7-9](#)
12G6133 [7-3](#)
12G6134 [7-3](#)
12G6135 [7-3](#)
12G6137 [7-9](#)
12G6138 [7-3](#)
12G6140 [7-3](#)
12G6141 [7-3](#)
12G6149 [7-7](#)
12G6150 [7-5](#)
12G6151 [7-7](#)
12G6153 [7-7](#)
12G6154 [7-7](#)
12G6156 [7-3](#)
12G6157 [7-9](#)
12G6158 [7-9](#)
12G6170 [7-9](#)
12G6171 [7-5](#)
12G6172 [7-9](#)
12G6173 [7-9](#)
12G6174 [7-5](#)
12G6175 [7-3](#)
12G6176 [7-9](#)
12G6177 [7-9](#)
7366857 [7-3](#)

Free Manuals Download Website

<http://myh66.com>

<http://usermanuals.us>

<http://www.somanuals.com>

<http://www.4manuals.cc>

<http://www.manual-lib.com>

<http://www.404manual.com>

<http://www.luxmanual.com>

<http://aubethermostatmanual.com>

Golf course search by state

<http://golfingnear.com>

Email search by domain

<http://emailbydomain.com>

Auto manuals search

<http://auto.somanuals.com>

TV manuals search

<http://tv.somanuals.com>