

Precision Cooling  
For Business-Critical Continuity™

## Liebert® XDC™

User Manual - 50 and 60 Hz, 130 & 160kW Nominal Cooling Capacity



## GENERAL SAFETY GUIDELINES

Before beginning the installation of the Liebert XDC, read all instructions, verify that all the parts are included, and check the nameplate to be sure the Liebert XDC voltage matches available utility power.

Follow all local codes.



### WARNING

Risk of electric shock. Can cause injury or death.  
Disconnect all local and remote electric power supplies before working within.



### WARNING

Risk of unit falling over. Can cause death, injury and equipment damage.  
The Liebert XDC is top-heavy. Use extreme caution and care when moving and installing this unit.



### CAUTION

Risk of piping and component rupture. Can cause injury or equipment damage. Closing service valves may isolate liquid refrigerant, causing high pressure and rupture of piping. Do not close valves without following recommended procedures for repair, maintenance and replacement of components. Install pressure relief valves in field piping that may become isolated by service valves.



### WARNING

Risk of refrigerant system explosion or rupture from overpressurization. Can cause injury, death or equipment damage.  
Installer must install a 400 psig pressure relief valve in each of the two R-407c refrigerant circuits of the Liebert XDC system. Do not install shutoff valves between the compressors and the pressure relief valves.  
For systems requiring EU CE compliance, the pressure relief valves must be CE-certified by a notified body to the EU Pressure Equipment Directive.



### CAUTION

Risk of contact with hot surfaces. Can cause burn injury. The compressors and refrigerant discharge lines are extremely hot during unit operation. Allow sufficient time for the compressors and refrigerant discharge lines to cool before working within the unit cabinet. Use extreme caution and wear protective gloves and arm protection when working on or near hot compressor and discharge lines.



### NOTE

This document shall be used together with site specific documentation and documentation for other parts of the system (heat rejection devices and cooling modules).



### NOTE

Before any action that could cause a disturbance in the XD system's cooling function is begun, the facility manager MUST be informed. In addition, after the action is taken and the work is finished, the facility manager MUST be informed.

Figure i Model number nomenclature

Example: XDC160AA--1

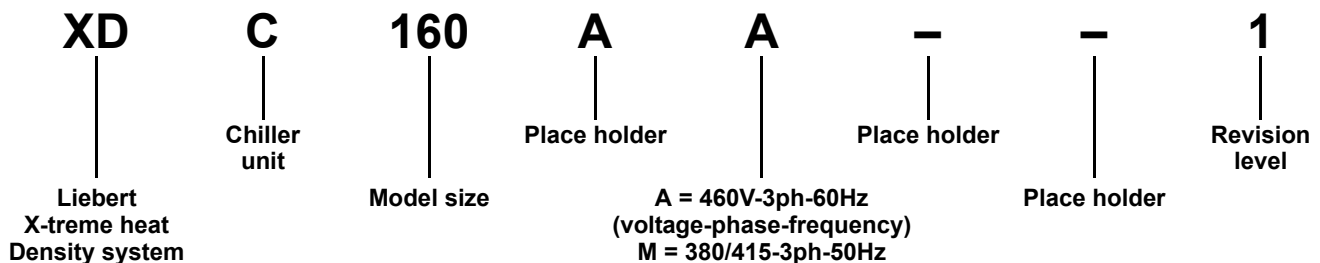

---

# TABLE OF CONTENTS

<b>GENERAL SAFETY GUIDELINES</b> .....	<b>INSIDE FRONT COVER</b>
<b>1.0 PRODUCT DESCRIPTION</b> .....	<b>1</b>
1.1 General Product Information .....	1
1.1.1 Product/System Description .....	1
1.2 Equipment Inspection .....	1
1.3 Equipment Handling .....	1
1.3.1 Handling With Skid .....	2
1.3.2 Removal of Skid .....	2
1.3.3 Removing Piano Jacks .....	4
1.4 Mechanical Considerations .....	4
1.4.1 Positioning the Liebert XDC .....	4
1.4.2 Placing the Liebert XDC on a Floor Stand .....	6
1.4.3 Positioning the Liebert XDC with Floor Stand .....	9
1.5 High Voltage Connections .....	10
1.5.1 Connecting High-Voltage Cables .....	10
1.6 Extra Low Voltage Connections .....	13
<b>2.0 PIPING AND FILLING WITH REFRIGERANT: R-134A AND R-407C CIRCUITS</b> .....	<b>16</b>
2.1 European Union Fluorinated Greenhouse Gas Requirements .....	16
2.2 Recommended Pipe Size .....	16
2.3 Liebert XDC Interconnection With Liebert XD Cooling Module .....	16
2.4 Piping Installation Method .....	17
2.4.1 Piping Installation—R-134a Pumped Circuit .....	17
2.5 Filling the Pumped Circuit—R-134a .....	20
2.5.1 Calculating Refrigerant Charge—Example .....	21
2.5.2 Piping for Direct Expansion (DX) Circuit—R-407c Air Cooled Units .....	22
2.6 Install Double Discharge Risers .....	22
2.6.1 Air Cooled Condenser with Lee-Temp “Flooded Condenser” Head Pressure Control System—R-407c (DX) Circuit .....	30
2.7 Filling the Direct Expansion (DX) Circuit—R-407c .....	31
<b>3.0 INSTALLATION CHECKLIST</b> .....	<b>32</b>
<b>4.0 CHECKLIST FOR LIEBERT XDC STARTUP</b> .....	<b>33</b>
4.1 System Refrigerant Charges Over 35 lb. (15.9kg) Require Additional Oil .....	34
<b>5.0 MICROPROCESSOR CONTROL</b> .....	<b>36</b>
5.1 Feature Overview .....	36
5.1.1 Display .....	36
5.2 Controls .....	37
5.2.1 Feature Overview .....	37
5.2.2 Status Display .....	37

---

5.3	Main Menu . . . . .	37
5.3.1	Viewing or Changing Settings . . . . .	37
5.3.2	SETPOINTS . . . . .	38
5.3.3	STATUS . . . . .	39
5.3.4	ACTIVE ALARMS . . . . .	39
5.3.5	ALARM HISTORY . . . . .	39
5.3.6	TIME . . . . .	39
5.3.7	DATE . . . . .	39
5.3.8	SETUP OPERATION . . . . .	40
5.3.9	SETPT PASSWORD . . . . .	42
5.3.10	SETUP PASSWORD . . . . .	42
5.3.11	CALIBRATE SENSORS . . . . .	43
5.3.12	ALARM ENABLE . . . . .	43
5.3.13	ALARM TIME DELAY . . . . .	44
5.3.14	COM ALARM ENABLE . . . . .	44
5.3.15	CUSTOM ALARMS . . . . .	44
5.3.16	CUSTOM TEXT . . . . .	45
5.3.17	DIAGNOSTICS . . . . .	45
<b>6.0</b>	<b>ALARM DESCRIPTIONS AND SOLUTIONS . . . . .</b>	<b>46</b>
6.1	Alarm Descriptions . . . . .	46
6.2	Red and Green Lamp Indicators . . . . .	47
6.3	Enable / Disable Alarms . . . . .	48
6.4	Alarm Time Delays . . . . .	48
6.5	View Active Alarms . . . . .	48
6.6	View Alarm History . . . . .	49
6.7	System Shutdown Causes . . . . .	49
<b>7.0</b>	<b>TROUBLESHOOTING . . . . .</b>	<b>50</b>
<b>8.0</b>	<b>MAINTENANCE . . . . .</b>	<b>52</b>
8.1	Fluorinated Greenhouse Gas Requirements . . . . .	52
8.2	Air Cooled Condenser . . . . .	52
8.3	Water/Glycol Floor Stand Condenser . . . . .	53
8.3.1	Shell and Tube Condensers . . . . .	53
8.3.2	Regulating Valves . . . . .	53
8.3.3	Glycol Solution Maintenance . . . . .	53
<b>9.0</b>	<b>SPECIFICATIONS . . . . .</b>	<b>54</b>

---

## FIGURES

Figure 1	Liebert XDC components . . . . .	1
Figure 2	Moving Liebert XDC with forklift . . . . .	2
Figure 3	Remove tie-down brackets . . . . .	3
Figure 4	Remove pallet, insert piano jacks. . . . .	3
Figure 5	Dimensional data . . . . .	4
Figure 6	Piping locations . . . . .	5
Figure 7	Water/glycol Liebert XDC on a floor stand—positioning and piping connections. . . . .	7
Figure 8	Piping locations—floor stand and valve assembly . . . . .	8
Figure 9	Dimensions and clearances for Liebert XDC on floor stand. . . . .	9
Figure 10	Front view of Liebert XDC and electrical enclosures . . . . .	10
Figure 11	Electrical enclosure knockout locations for field wiring. . . . .	11
Figure 12	60Hz models, high voltage connections—primary disconnect switch . . . . .	11
Figure 13	50Hz models high voltage connections—primary disconnect switch . . . . .	12
Figure 14	60Hz models high voltage connections—secondary disconnect switch . . . . .	12
Figure 15	50Hz models high voltage connections—secondary disconnect switch . . . . .	13
Figure 16	Liebert XDC heat rejection connection points. . . . .	13
Figure 17	Electrical enclosure knockout locations for Extra Low Voltage connections. . . . .	14
Figure 18	Extra Low Voltage field connections points . . . . .	15
Figure 19	Liebert XD system diagram . . . . .	17
Figure 20	Bypass flow controller details, dimensions . . . . .	18
Figure 21	Bypass flow controller arrangement . . . . .	18
Figure 22	Bypass flow controller piping . . . . .	19
Figure 23	Double discharge riser layout. . . . .	22
Figure 24	Installation data—Lee-Temp, one-circuit, four-fan model . . . . .	24
Figure 25	Installation data—Lee-Temp, one-circuit, high ambient six-fan model . . . . .	25
Figure 26	Liebert XDC piping schematic and Lee-Temp heater pad wiring . . . . .	26
Figure 27	General arrangement air cooled Liebert XDC Lee-Temp Control . . . . .	27
Figure 28	DCSL616 piping connections—two refrigerant circuits connected for parallel flow. . . . .	28
Figure 29	CSL616 piping connections—two refrigerant circuits connected for parallel refrigerant flow. . . . .	29
Figure 30	Additional oil requirements for refrigerant charge. . . . .	34
Figure 31	System R-134a liquid level . . . . .	35
Figure 32	User interface . . . . .	36
Figure 33	Outdoor fan/condenser configuration. . . . .	52

## TABLES

Table 1	Liebert XDC dimensions, weight . . . . .	4
Table 2	Liebert XDC piping connection sizes . . . . .	5
Table 3	Liebert XDC water/glycol piping connection Sizes . . . . .	7
Table 4	Supply, return pipe sizes for Liebert XD refrigerant loop . . . . .	16
Table 5	Bypass flow controllers for a Liebert XDC-based system . . . . .	18
Table 6	System R-134a charge for a Liebert XDC with any model Liebert XDH/Liebert XDO/Liebert XDV/Liebert XDCF . . . . .	20
Table 7	System refrigerant charge for the supply and return mains . . . . .	20
Table 8	R-134a refrigerant charge for hard-piped connector lines to and from any model Liebert XDH/Liebert XDO/Liebert XDV/Liebert XDCF . . . . .	20
Table 9	R-134a refrigerant charge for Liebert XD Flex Pipe connector lines to and from any model Liebert XDO/Liebert XDH/Liebert XDV/Liebert XDCF . . . . .	21
Table 10	Calculating refrigerant charge—example . . . . .	21
Table 11	Worksheet to calculate refrigerant charge . . . . .	21
Table 12	Recommended refrigerant line sizes, DX R-407c, OD copper . . . . .	27
Table 13	Recommended refrigerant line sizes for DCSL616 . . . . .	28
Table 14	Indoor unit refrigerant charge—R-407c . . . . .	31
Table 15	Outdoor air condenser charge—R-407c . . . . .	31
Table 16	Air cooled systems - liquid line charge - R-407c refrigerant per 100 ft (30 m) of Type "L" copper tube . . . . .	31
Table 17	Indoor water/glycol cooled module – R-407C refrigerant charge . . . . .	31
Table 18	Liebert XDC pump light indicator *. . . . .	33
Table 19	Compressor oil types . . . . .	34
Table 20	User interface keypad functions. . . . .	36
Table 21	Setpoint functions, default values and allowable ranges . . . . .	38
Table 22	Setup operation functions default values and allowable ranges. . . . .	40
Table 23	Liebert XDC DIP switches and factory settings . . . . .	41
Table 24	Liebert XDC troubleshooting . . . . .	50
Table 25	Liebert XDC specifications . . . . .	54
Table 26	Floor stand specifications—water-cooled Liebert XDC. . . . .	55
Table 27	Floor stand specifications—Liebert XDC with 40% propylene glycol . . . . .	55
Table 28	Floor stand specifications—Liebert XDC with 40% ethylene glycol . . . . .	56

## 1.0 PRODUCT DESCRIPTION

### 1.1 General Product Information

#### 1.1.1 Product/System Description

The Liebert XDC™ (eXtreme Density Chiller) is self-contained refrigeration distribution unit designed to cool rooms with high heat producing equipment. There are two distinct circuits, each utilizing different refrigerants and mechanical parts. The R-134a circuit is the “pumped” circuit containing redundant circulating pumps, a brazed plate heat exchanger along with valves and piping. The R-407c circuit is the dual direct expansion circuit containing scroll compressors, expansion valves, brazed plate heat exchanger, and piping. Heat removal is accomplished by using condensers connected to the dual direct expansion circuit. Heat rejection is available in two options: an outdoor air cooled condenser and a water/glycol condenser. See **Figure 1** below.

The Liebert XDC monitors room conditions and prevents coil condensation by maintaining the coolant being pumped to the cooling modules at a temperature above the room dew point. All functions, such as temperature control, switching pumps (if necessary), etc., are automatic.

The Liebert XDC’s minimum recommended operating load is 40% of system nominal capacity. For example, a Liebert XDC160 60Hz system’s minimum load would be 64 kW. Loading below this value can unfavorably affect system operation. Consult factory for any loading below this recommendation.

See **Table 25** for the Liebert XDC160 rated cooling capacity.

**Figure 1** Liebert XDC components

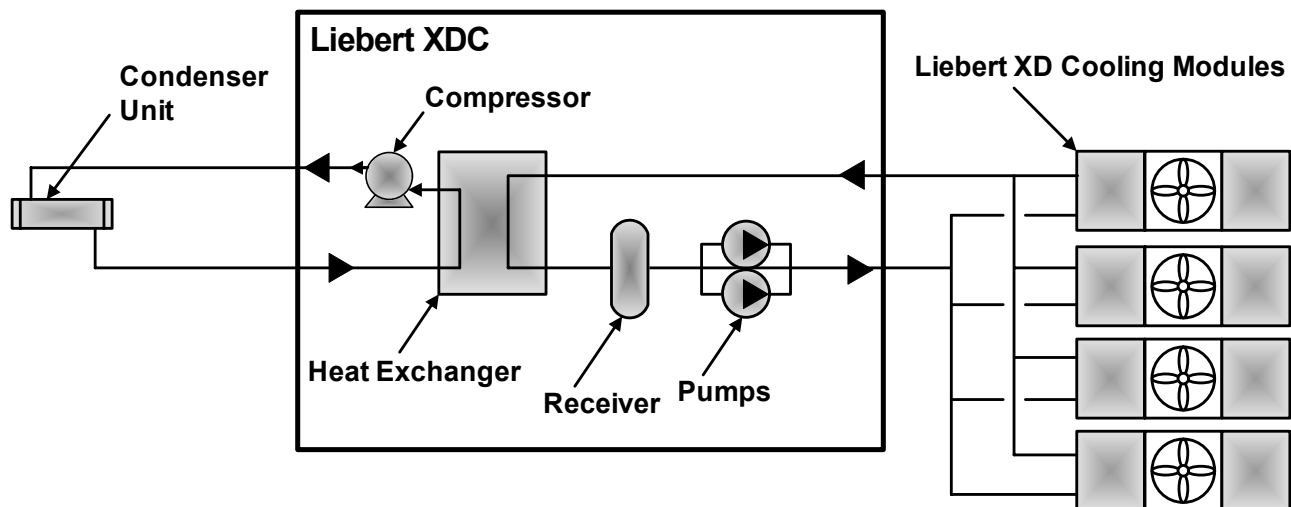

### 1.2 Equipment Inspection

When the unit is delivered, inspect all items for visible and concealed damage. Damage should be immediately reported to the carrier and a damage claim filed with a copy sent to Liebert or to your sales representative.

### 1.3 Equipment Handling



#### **WARNING**

Risk of unit falling over. Can cause death, injury and equipment damage.

The Liebert XDC is top-heavy. Use extreme caution and care when moving and installing this unit.

### 1.3.1 Handling With Skid

- Always keep the unit upright, indoors and protected from damage.
- If possible transport the unit using a forklift truck; otherwise use a crane with belts or cables. When using a crane, apply spreader bars to avoiding pressing on the top edges of the packaging.
- Personnel should be properly certified and trained to move and rig equipment.
- If using a forklift truck, make sure that the forks (if adjustable) are spread to the widest allowable distance that will fit under the skid.
- When moving the skidded unit with a forklift truck, do not lift the unit any higher than 6" (152mm) off the ground. If circumstances require the unit to be lifted higher than 6" (152mm), great care must be exercised, and all personnel not directly involved in raising the unit must be no closer than 20 feet (5m) from the lift point of the unit.



## CAUTION

Risk of structural interference. Can cause equipment or building damage.

While on the skid, the unit is too tall (83" [2108mm] overall height) to fit through a standard doorway 83" [2108mm]. Any attempt to move the unit, while skidded, through a standard doorway will cause damage to the unit and to the building.

### 1.3.2 Removal of Skid

For skid removal, Emerson Network Power recommends using pallet jack or similar operation. This is to ensure that both ends of the unit are firmly secure, and provides a good means of unit mobility.

Always keep the unit upright, indoors and protected from damage.

1. Remove the exterior packaging.
2. Align forklift with either the front or rear of the unit. Ensure the forks are locked at the widest position that will fit under pallet (see **Figure 2**).

**Figure 2** Moving Liebert XDC with forklift

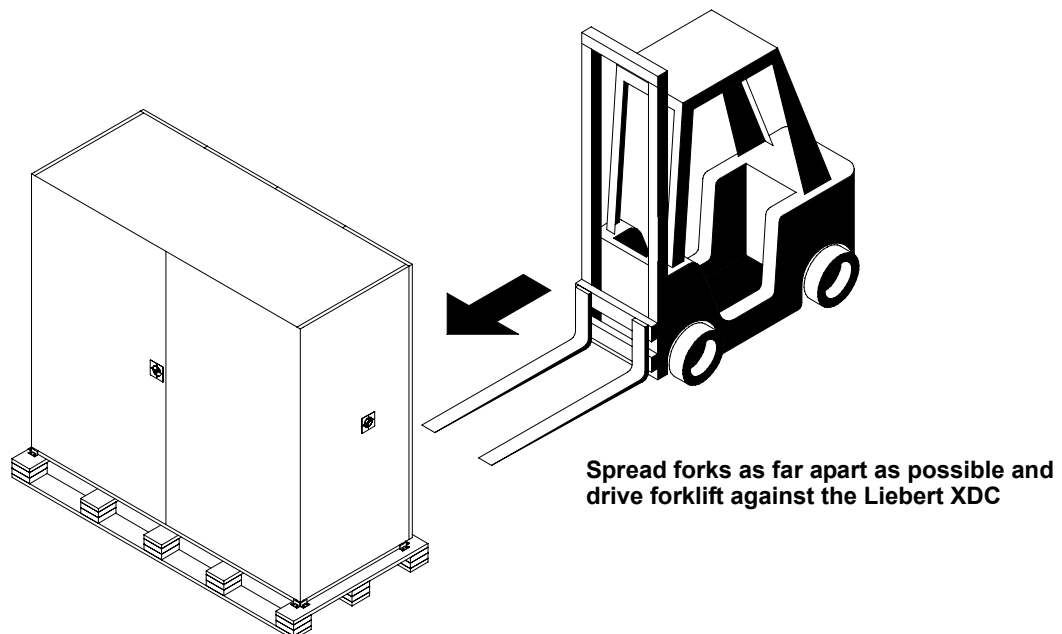

## CAUTION

Risk of unit damage. Ensure the forklift tines are level and not angled in an upward direction. Improper positioning may cause damage to the bottom of the unit. Ensure the forks are positioned in a manner as to have the Center of Gravity label, located on the unit, centered between the tines. Ensure the tines extend beyond the opposite side of the unit.

3. Drive the forklift forward, sliding the forks under the base of the unit (see **Figure 2**).



4. Move the Liebert XDC to its installation location.



## WARNING

Risk of unit falling over. Can cause death, injury and equipment damage.

The Liebert XDC is top-heavy. Use extreme caution and care when moving and installing this unit.

5. Remove all lag bolts from the four (4) corner tie-down brackets. Remove the tie-down brackets from the unit. (see **Figure 3**).

**Figure 3 Remove tie-down brackets**

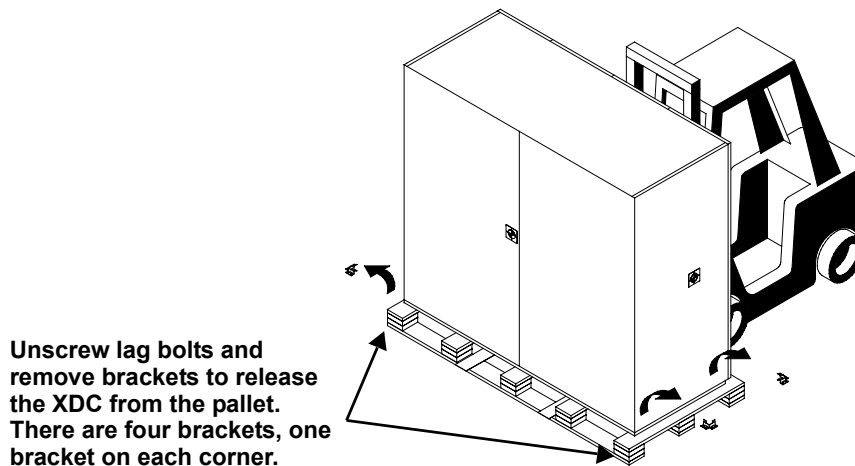

6. Lift the Liebert XDC about an inch and remove the shipping pallet.

**Figure 4 Remove pallet, insert piano jacks**

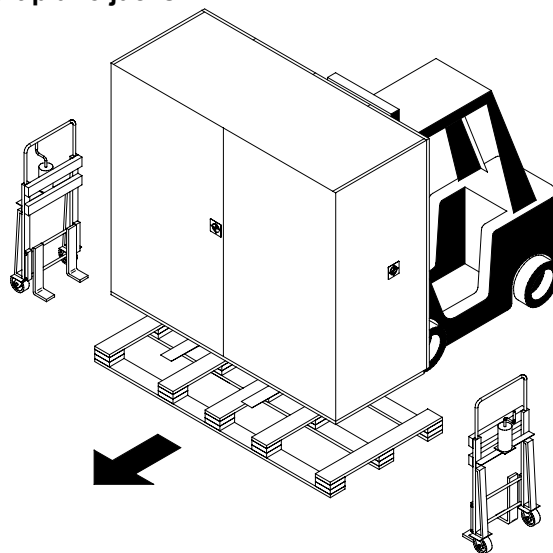

7. Place piano jacks at either end of the Liebert XDC and lower it until it is supported by the piano jacks. Secure the Liebert XDC to the jacks (see **Figure 4** for arrangement).



## CAUTION

Risk of overtightening securing strips. Can cause damage to panels.

Place a protective material between the straps of the piano jacks and the unit.

Ensure that the straps are not tightened to a point of damaging panels.

8. Back the forklift away from the Liebert XDC until the forks are no longer under the unit.
9. Using the piano jacks, maneuver the Liebert XDC into its installation position—this requires at least two people.

### 1.3.3 Removing Piano Jacks

Once the unit has been moved to the installation location, Emerson Network Power recommends using the following method to remove the piano jacks.

1. Lower the unit as far as the piano jacks will allow.
2. Undo all strapping holding the piano jacks to the unit.
3. Remove all cushioning material that might have been used to protect the unit panels from the strapping and/or the piano jacks.
4. Use a pry bar or similar device on one side of the unit, lift unit just enough to allow for the removal of the piano jack.
5. Repeat the previous step to remove the piano jack on the opposite side.
6. Remove the plastic bag.

## 1.4 Mechanical Considerations

### 1.4.1 Positioning the Liebert XDC

Install the Liebert XDC according to the site specific documentation and secure the unit to the floor.

The Liebert XDC can be installed near a wall or another Liebert XDC. However, there must be at least 3 feet (92cm) clearance in front of the Liebert XDC as service access for components in the unit.



**NOTE**

*During installation of the Liebert XDC, the top, bottom, front and left side of the unit must be accessible.*

**Figure 5 Dimensional data**

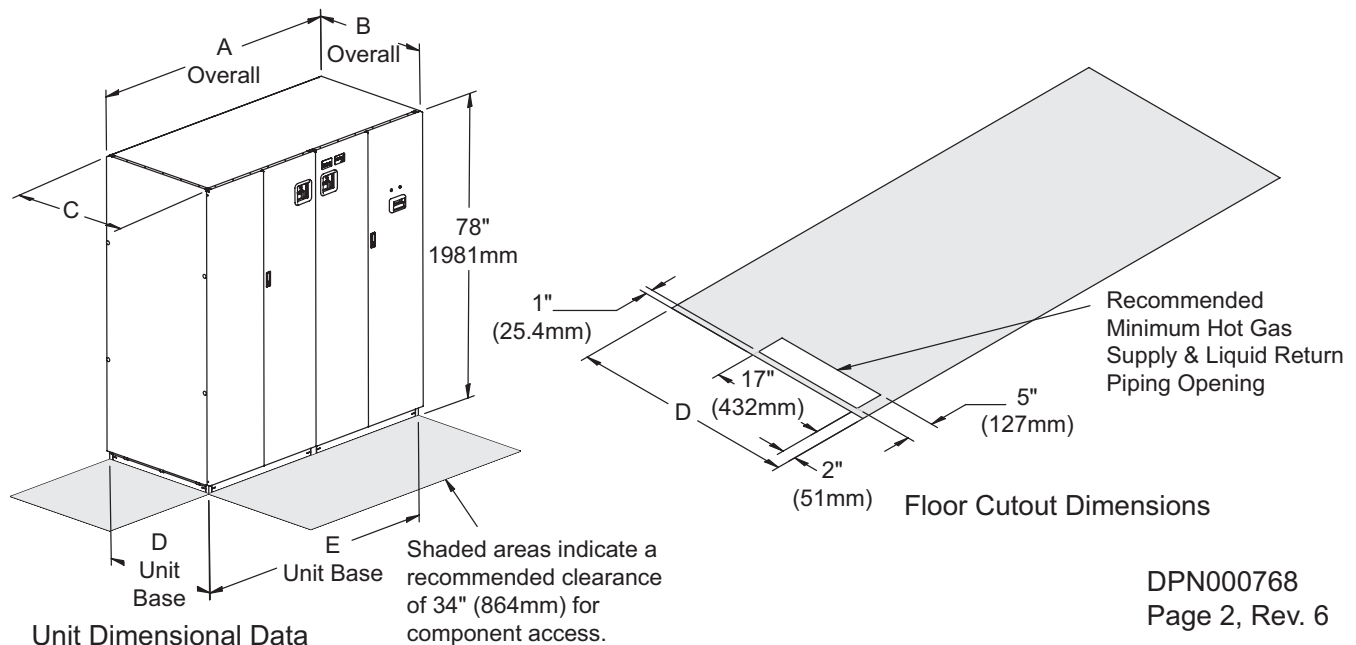
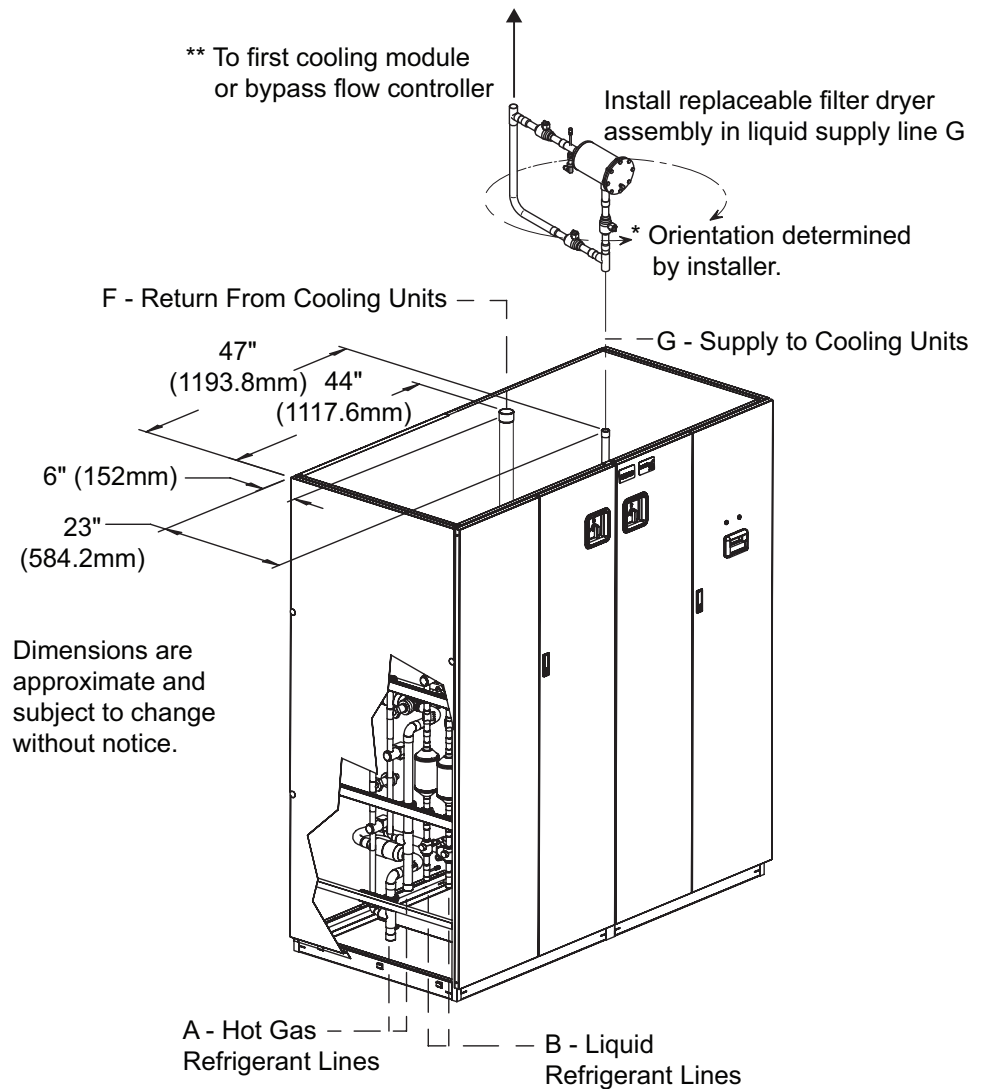

**Table 1 Liebert XDC dimensions, weight**

Air Cooled Model	Dimensional Data, inches (mm)					Shipping Weight, lb (kg)	
	A	B *	C	D	E	Domestic	Export
XDC160	74 (1880)	34 (864)	33-1/8 (841)	33 (838)	72 (1829)	1945 (882)	2093 (949)

\* Dimension does not include the bezel of the disconnect switch.

Figure 6 Piping locations



\* Allow 8" (204mm) of clearance for filter replacement

\*\* To ensure all refrigerant flow is filtered, install the filter dryer assembly between the discharge line of the Liebert XDC and the first bypass flow controller or the first cooling module.

DPN000768  
Page 3, Rev. 6

Table 2 Liebert XDC piping connection sizes

Air Cooled Model	Piping Outlet Connection Sizes, OD Cu, inches						
	A	B	C	D	E	F	G
50/60Hz							
XDC160	1-3/8	7/8	-	-	-	2-1/8	1-1/8

## 1.4.2 Placing the Liebert XDC on a Floor Stand



### WARNING

Risk of top-heavy unit falling over. Improper handling can cause equipment damage, injury or death.

Read all of the following instructions before attempting to move, lift, remove packaging from or preparing unit for installation.



### CAUTION

Only properly trained and qualified personnel wearing appropriate safety headgear, gloves, shoes and glasses should attempt to move, lift, remove packaging from or prepare unit for installation.

The water/glycol floor stand can be located beneath the XDC unit or can be installed nearby.



### NOTE

*Consult the factory if the XDC is not installed on the water/glycol condenser floor stand to prevent exceeding maximum the piping distances.*

Refer to the floor stand installation sheet shipped inside the water regulating valve package.

1. Move the floor stand assembly to its installation area and uncrate the unit.
2. Position the floor stand in its final location.
3. Insert leveler pads into each floor stand leg.
4. Level the top of the floor stand to the specified height with the flanged adjusting nut.
5. Tighten jam nuts on all legs against flanged adjusting nuts.
6. Using an appropriate lifting device or method, raise the Liebert XDC and move it above the floor stand.
7. Align the welded tabs on top of the floor stand with the inside of the unit frame base (see Detail A in **Figure 7**).
8. Maintaining the alignment of the Liebert XDC and the floor stand, lower the Liebert XDC onto the floor stand.
9. Connect the hot gas refrigerant lines from the Liebert XDC to the floor stand with 1-3/8" tubing (see **Figures 7** and **8**).
10. Connect the liquid refrigerant lines as shown from the Liebert XDC unit to the floor stand with 7/8" tubing (see **Figures 7** and **8**).
11. Connect the water lines as shown with the provided valving (see **Figures 7** and **8**).
12. Connect capillary lines from each water regulating valve to condensers in the floor stand (see **Figures 7** and **8**).  
Capillary length is limited to 48" (1219mm).
13. Check the pipes for leaks and evacuate air from all pipes.
14. Insulate all water/glycol lines.
15. Charge each condenser loop with R-407c (see **Table 17**).

Figure 7 Water/glycol Liebert XDC on a floor stand—positioning and piping connections

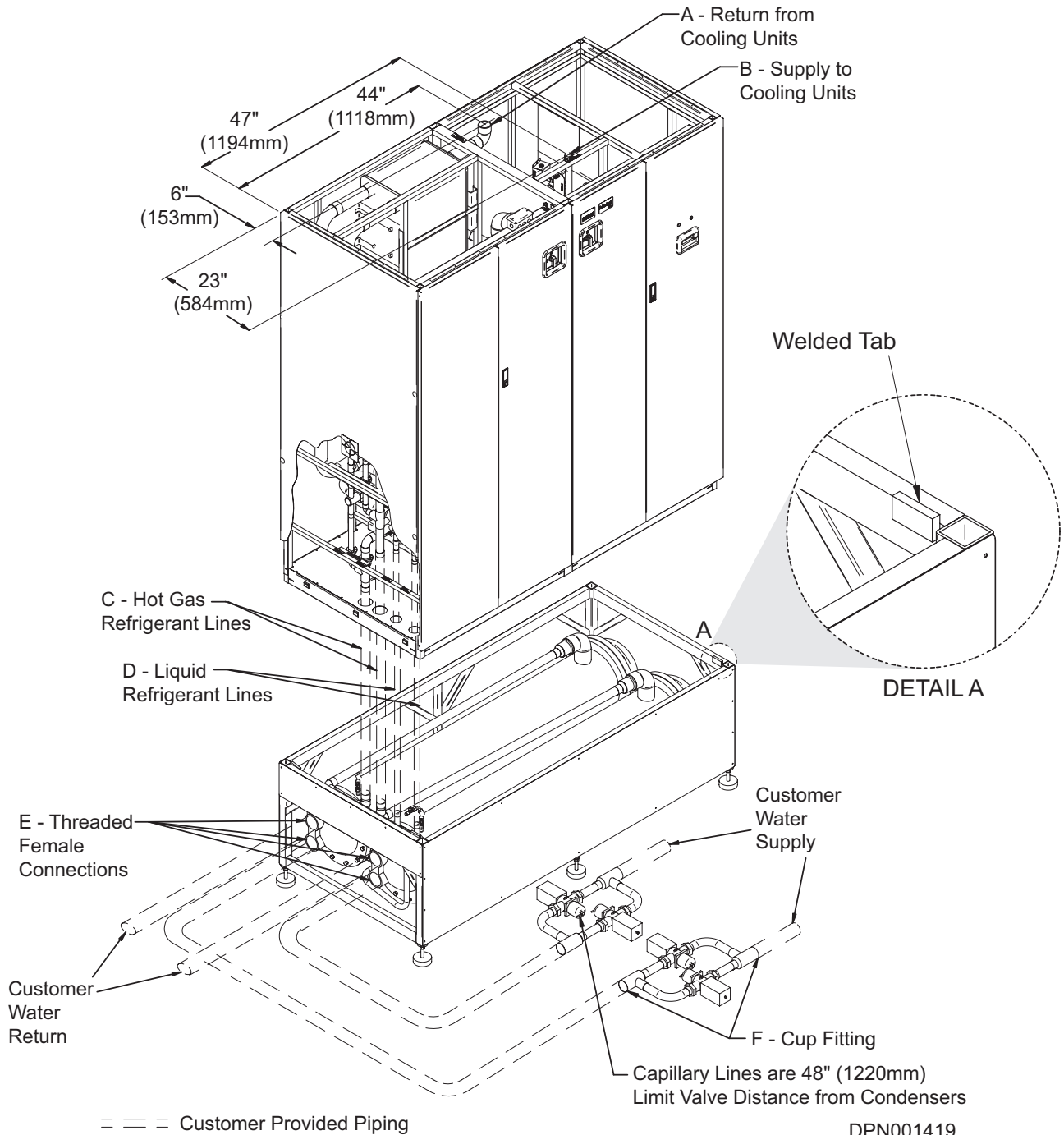

DPN001419  
Pg. 01, Rev. 01

Table 3 Liebert XDC water/glycol piping connection Sizes

Model	Piping Outlet Connection Sizes, OD Cu, inches					
	A	B	C	D	E*	F**
XDC160	2-1/8	1-1/8	1-3/8	7/8	2-1/2	2-1/8 or 2-5/8

\* Threaded Female Connection

\*\* 2-1/8" for 1" WRV, 2-5/8" for 1-1/4" WRV

Figure 8 Piping locations—floor stand and valve assembly

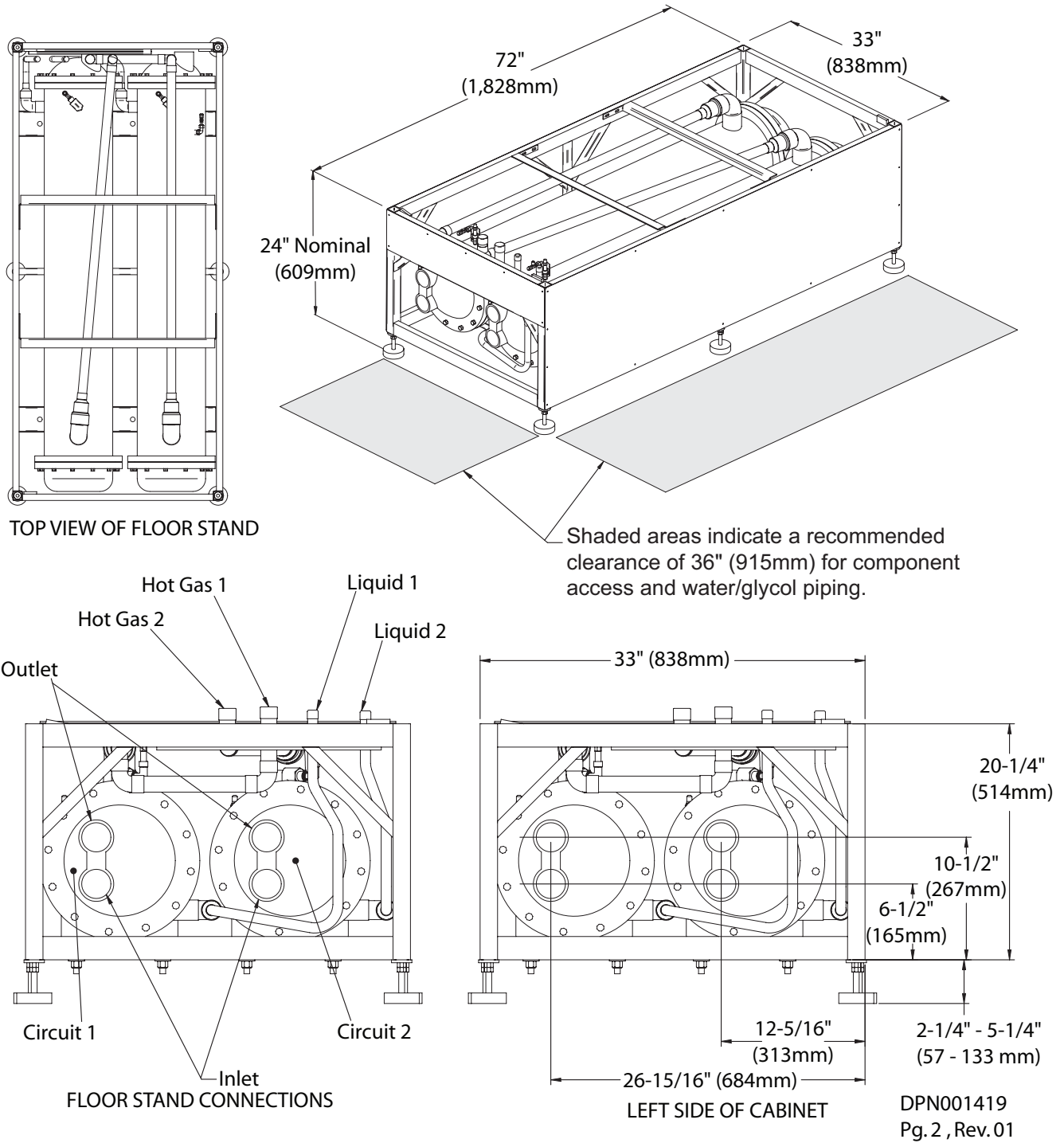

### 1.4.3 Positioning the Liebert XDC with Floor Stand

Install the Liebert XDC according to the site-specific documentation and secure the unit to the floor. The Liebert XDC can be installed near a wall or another Liebert XDC. There must be at least 3 feet (914mm) clearance in front of the Liebert XDC for service access. When the Liebert XDC is combined with the optional water/glycol floor stand, Liebert recommends leaving 3 feet (914mm) of clearance on the left side of the unit.

A Liebert XDC on a floor stand is 102 inches (2591 mm) high (see **Figure 9**). The unit can be raised or lowered 1.5 inches (38.1 mm) with the leveling feet.

**Figure 9** Dimensions and clearances for Liebert XDC on floor stand

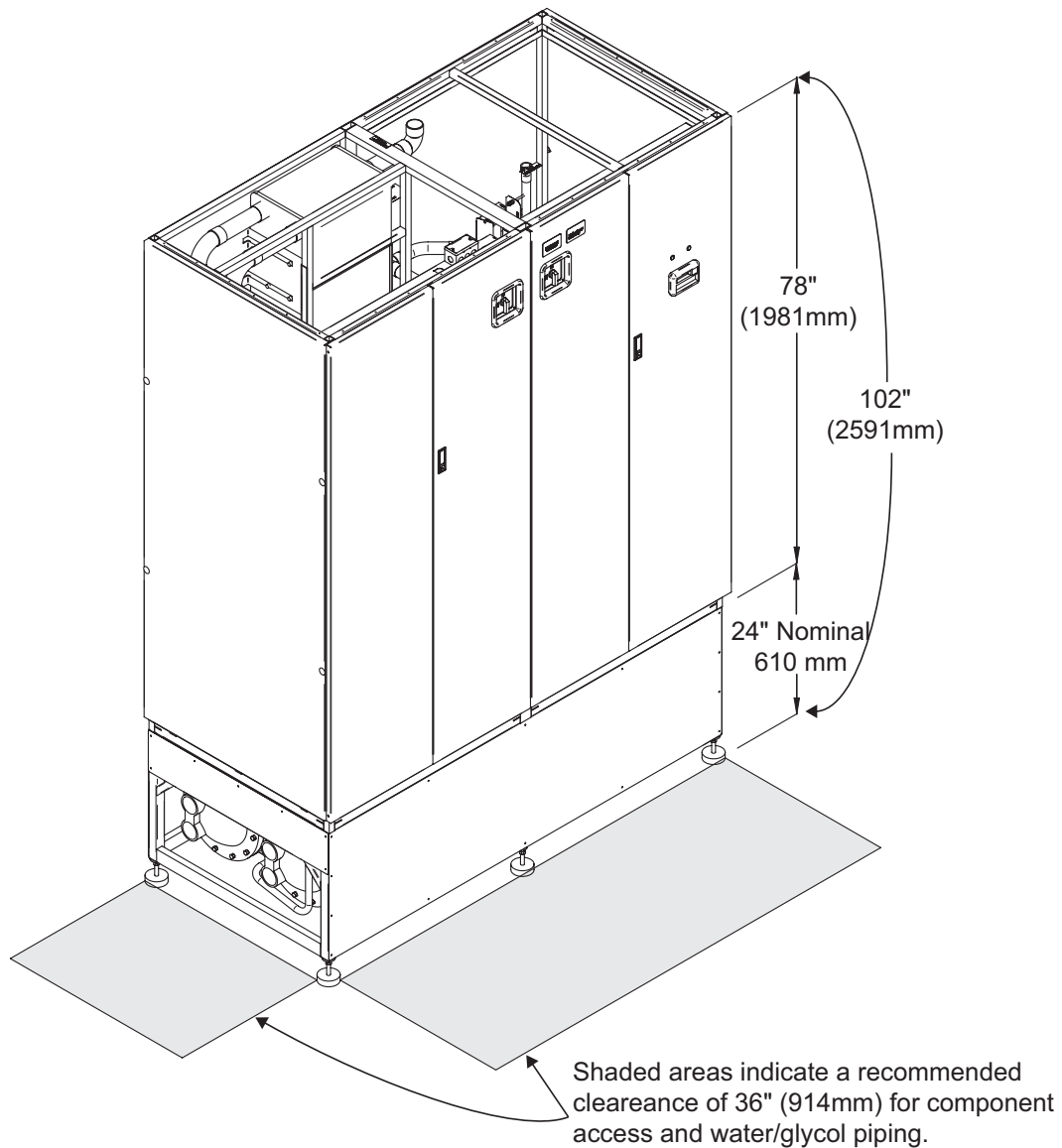

## 1.5 High Voltage Connections

Make sure the actual supply voltage and frequency correspond to the voltage and frequency indicated on the Liebert XDC's rating plate.

Connect cables for high voltage supply to the electrical box in the Liebert XDC according to **Figures 5, 11 and 12** and make sure that the phases are correctly connected.



### WARNING

Risk of electric shock. Can cause death or injury.

Disconnect all local and electric remote power supplies before working within.



### CAUTION

Risk of sharp edges and heavy parts. May cause personal injury or equipment damage.

Wear gloves to prevent injury to hands.

Damage to wiring or components can make unit unsafe to operate.

Use caution when installing wiring to prevent damage to factory wiring.

Install protective bushings in wiring knockouts as required

Do not disturb factory wiring or route field-installed wiring over electrical terminals.

Use NEC Class 1 wiring for all hazardous voltage electrical power supplies.

Check and retighten **all** wiring connections before starting the unit.



### NOTE

*Before beginning to install the Liebert XDC, read all instructions, verify that all the parts are included and check the nameplate to be sure the Liebert XDC voltage matches available utility power.*

*Follow all local codes.*

### 1.5.1 Connecting High-Voltage Cables

1. Turn the Liebert XDC's primary disconnect switch to the Off position (see **Figure 10**). Open the front doors and push down on the enclosure cover latch to open the hazardous voltage enclosure cover.

**Figure 10 Front view of Liebert XDC and electrical enclosures**

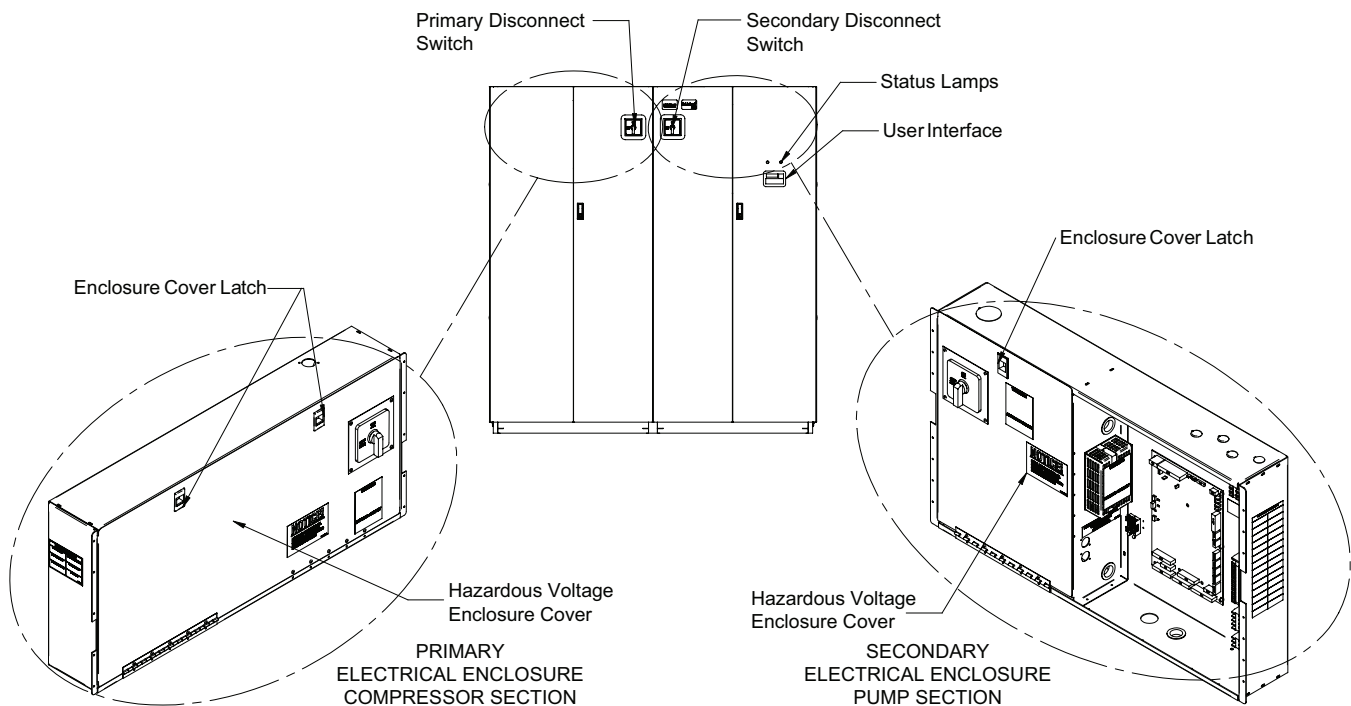



- Determine which knockouts in the electrical enclosure will be used and remove them (see **Figure 11**).

**Figure 11 Electrical enclosure knockout locations for field wiring**

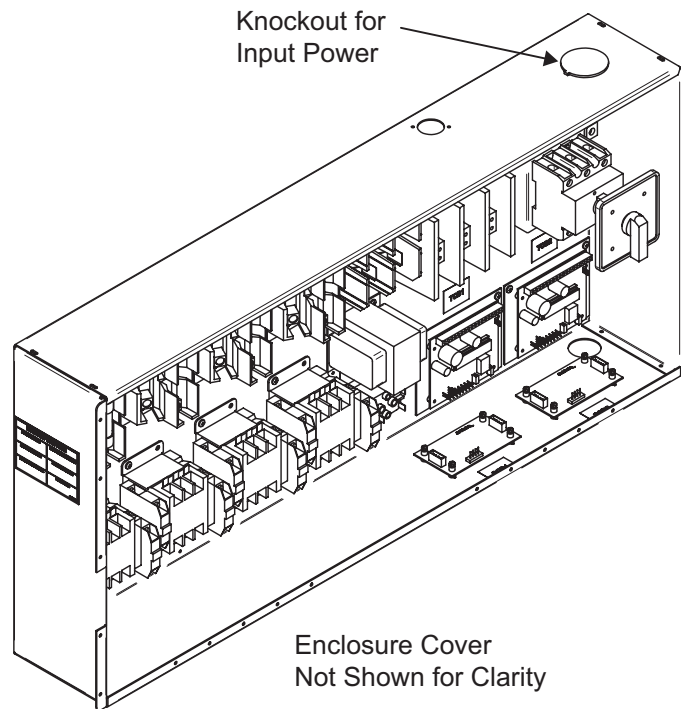

- Route the input hazardous voltage electrical power wiring through the top right knockout on the primary electrical enclosure (see **Figure 11**) to the disconnect switch L1, L2 and L3 (see **Figure 12**). Observe proper phasing.
- Connect the ground wire to the ground lug (see **Figures 12 and 14** for 60Hz models and **Figures 13 and 15** for 50Hz models).

**Figure 12 60Hz models, high voltage connections—primary disconnect switch**

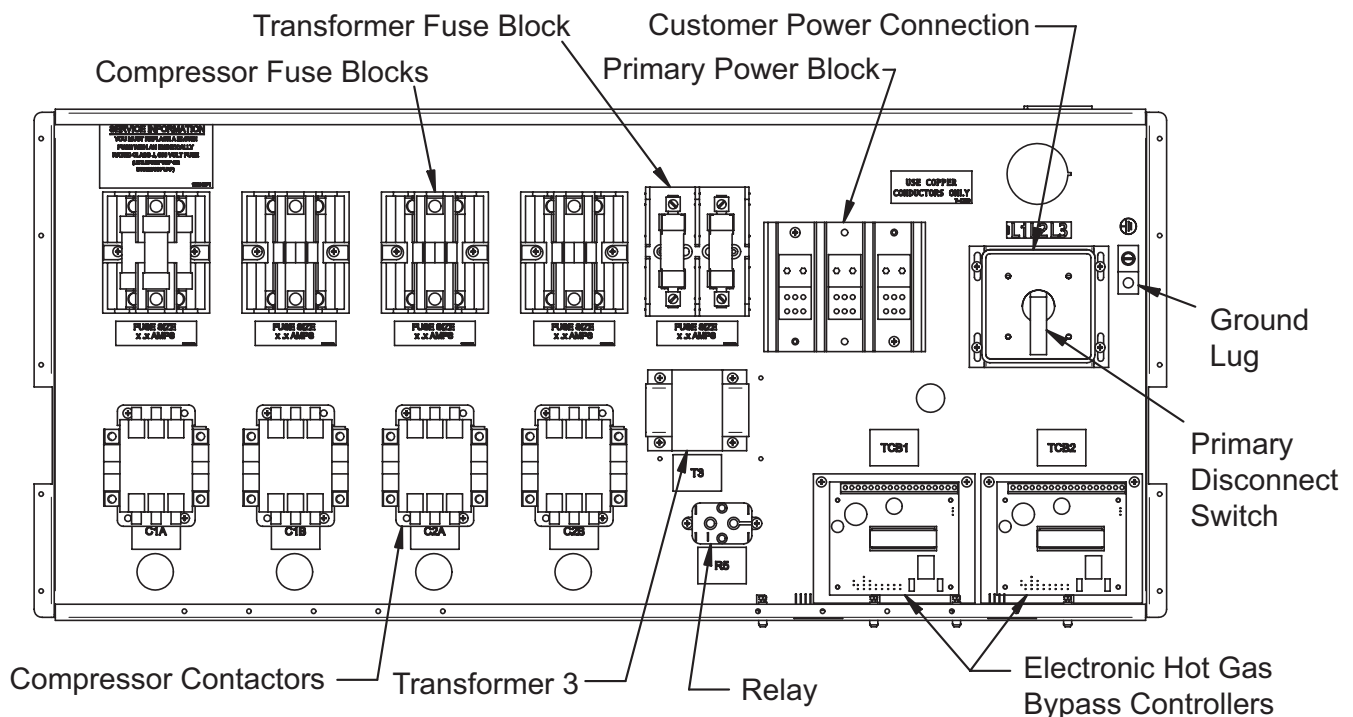

Figure 13 50Hz models high voltage connections—primary disconnect switch

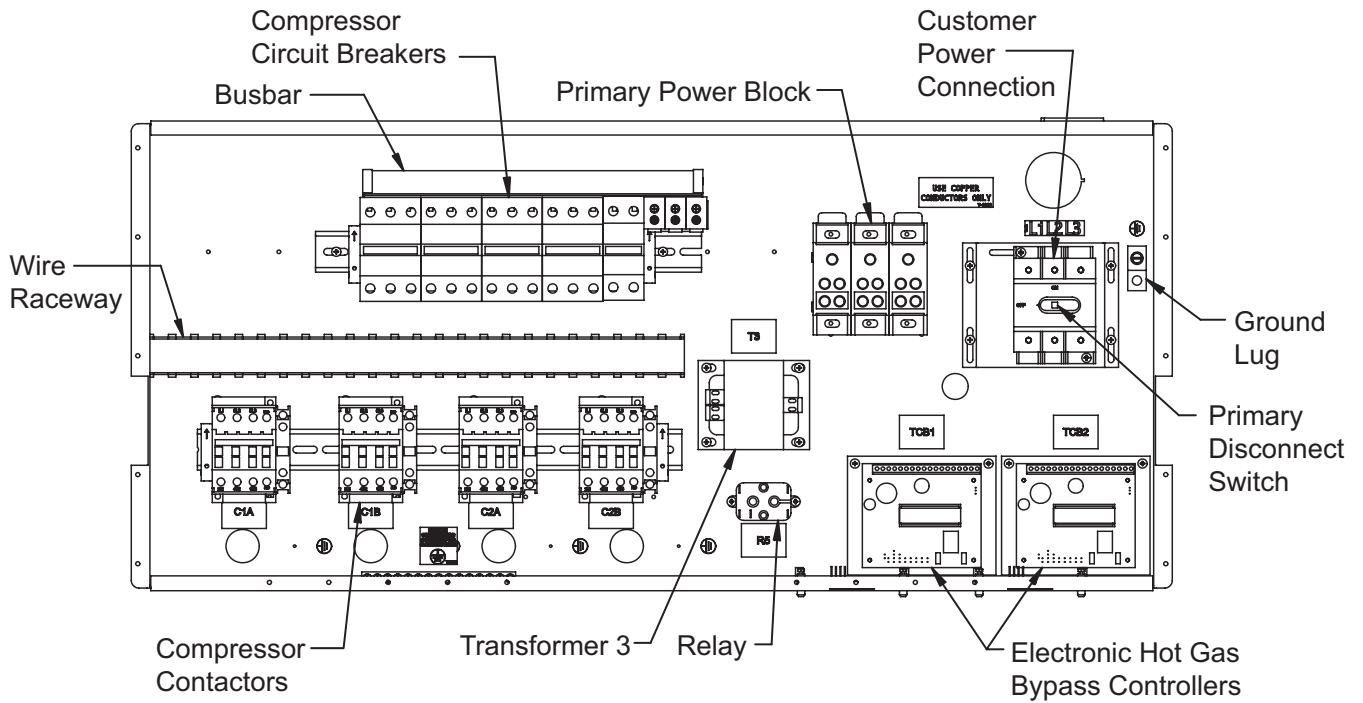
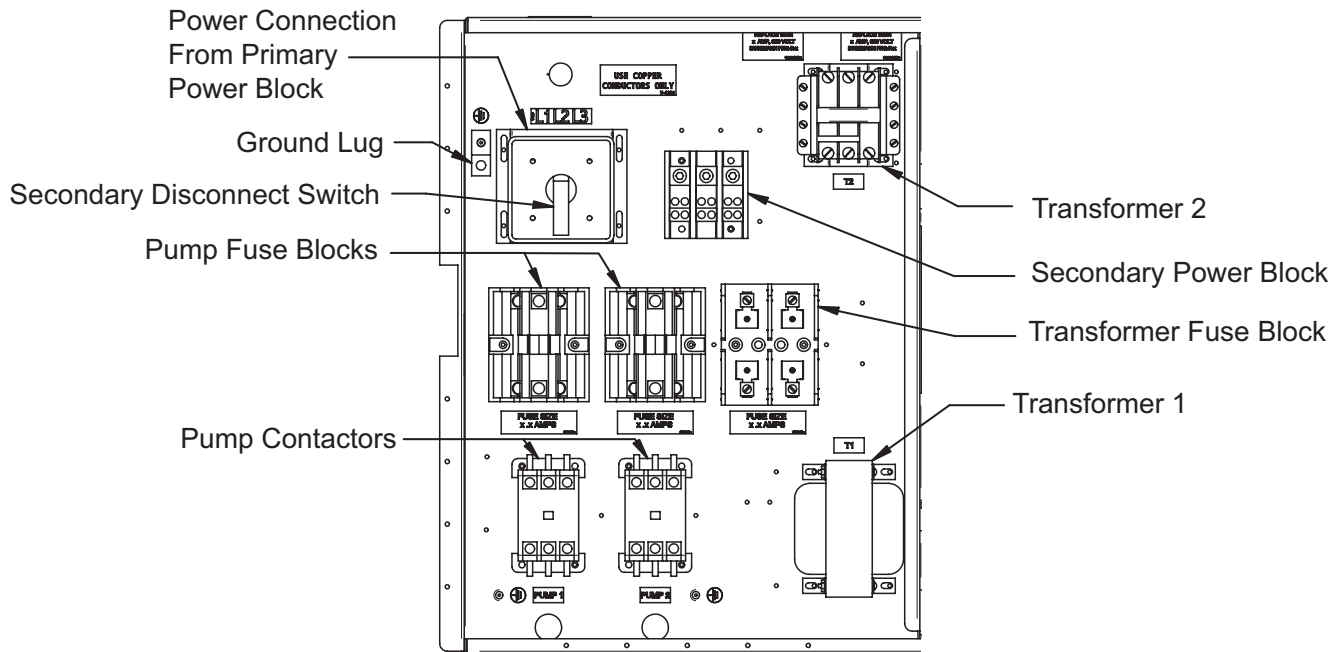
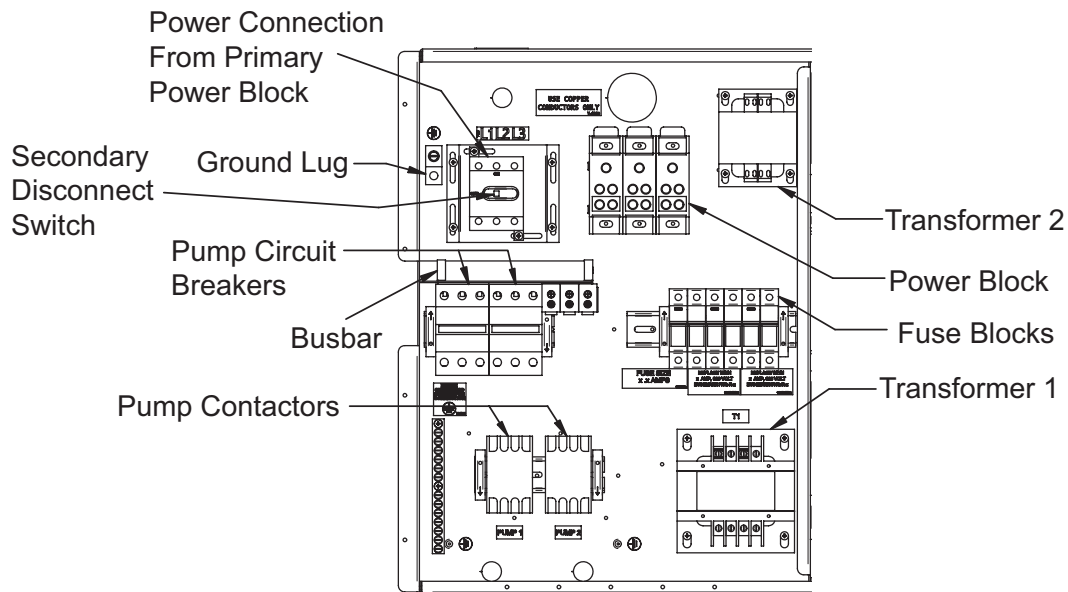

Figure 14 60Hz models high voltage connections—secondary disconnect switch



**Figure 15 50Hz models high voltage connections—secondary disconnect switch**



### 1.6 Extra Low Voltage Connections

Extra Low Voltage (ELV) power output is 30V and 100VA or less.

1. Turn off all unit power before connecting cables or wires. Failure to do so may damage this equipment.
2. Route low voltage electrical connections through the appropriate knockouts as shown in **Figure 17**.
3. User interface and temperature/humidity sensor wire is NEC Class 2. All electrical installation must comply with all national, state and local requirements.

**Figure 16 Liebert XDC heat rejection connection points**

HEAT REJECTION CONNECTION  
 Field-supplied 24V, Class 1 wiring  
 to interlock heat rejection from pigtails:  
 70A and 71A - Compressor 1 circuit  
 70B and 71B - Compressor 2 circuit  
 70C and 71C - Dual Source relay (optional)

Electrical handy box,  
 factory-installed with cover

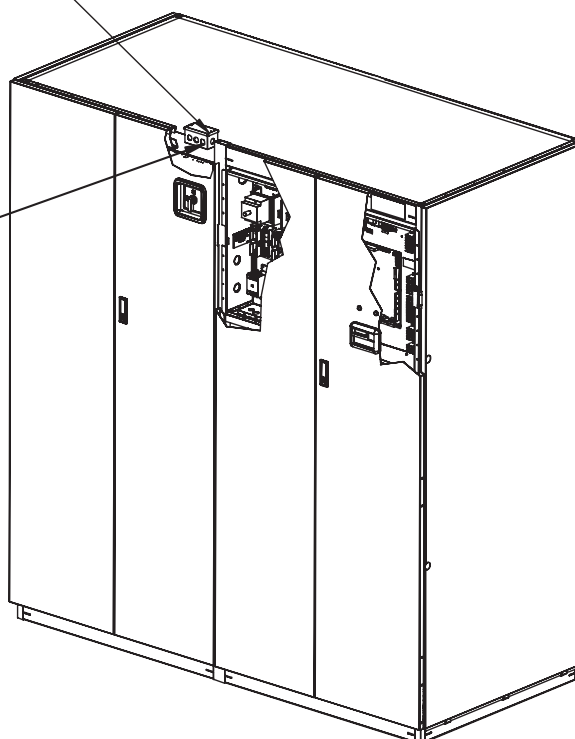

**Figure 17 Electrical enclosure knockout locations for Extra Low Voltage connections**

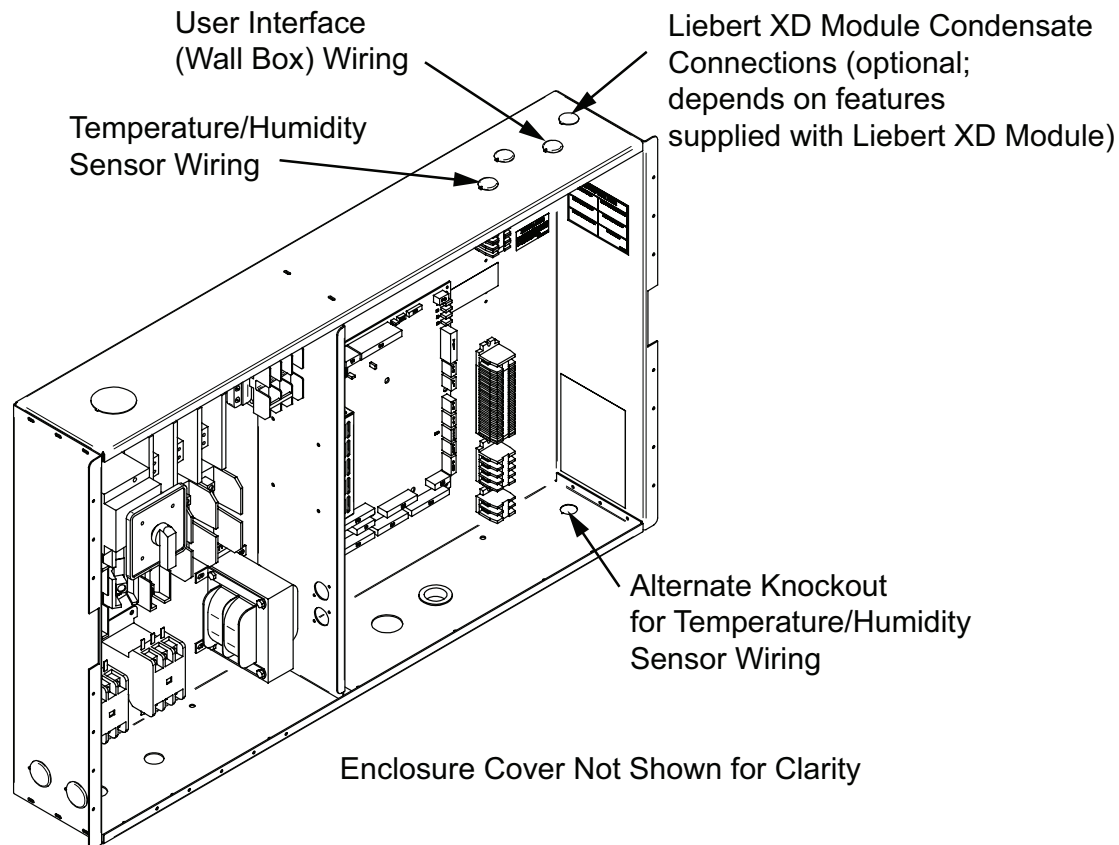

### Field Connections—All Units

- Connect the control display panel cable to terminal block TB3 terminals 1 through 4 on the Liebert XDC control board as shown (refer to **Figure 18**). The display panel must always be installed in the conditioned space. The display panel may be mounted on the Liebert XDC's front right door *if the Liebert XDC is located in the area that it conditions*.
- Place the sensor in the higher-temperature portion of the cold aisle where the XD modules are located. Alternatively, it may be placed on the return air side of the primary air mover (e.g., Liebert Deluxe System/3™) in the room if it represents the conditions where all the XD cooling modules are located. Do not install the sensor where ambient air might cause false readings, for example, near unsealed doors, windows and similar areas..

### Field Connections—Optional for All Units

- Connect optional field wiring from remote devices to Remote Alarm Device, Common Alarm Output, IGM and Remote Shutdown, if applicable. See terminal strip descriptions in **Figure 18**.

### Field Connections—Air Cooled Units only

Connect field wiring to heat rejection connection terminals on the handy box as shown in **Figure 16**.

Figure 18 Extra Low Voltage field connections points

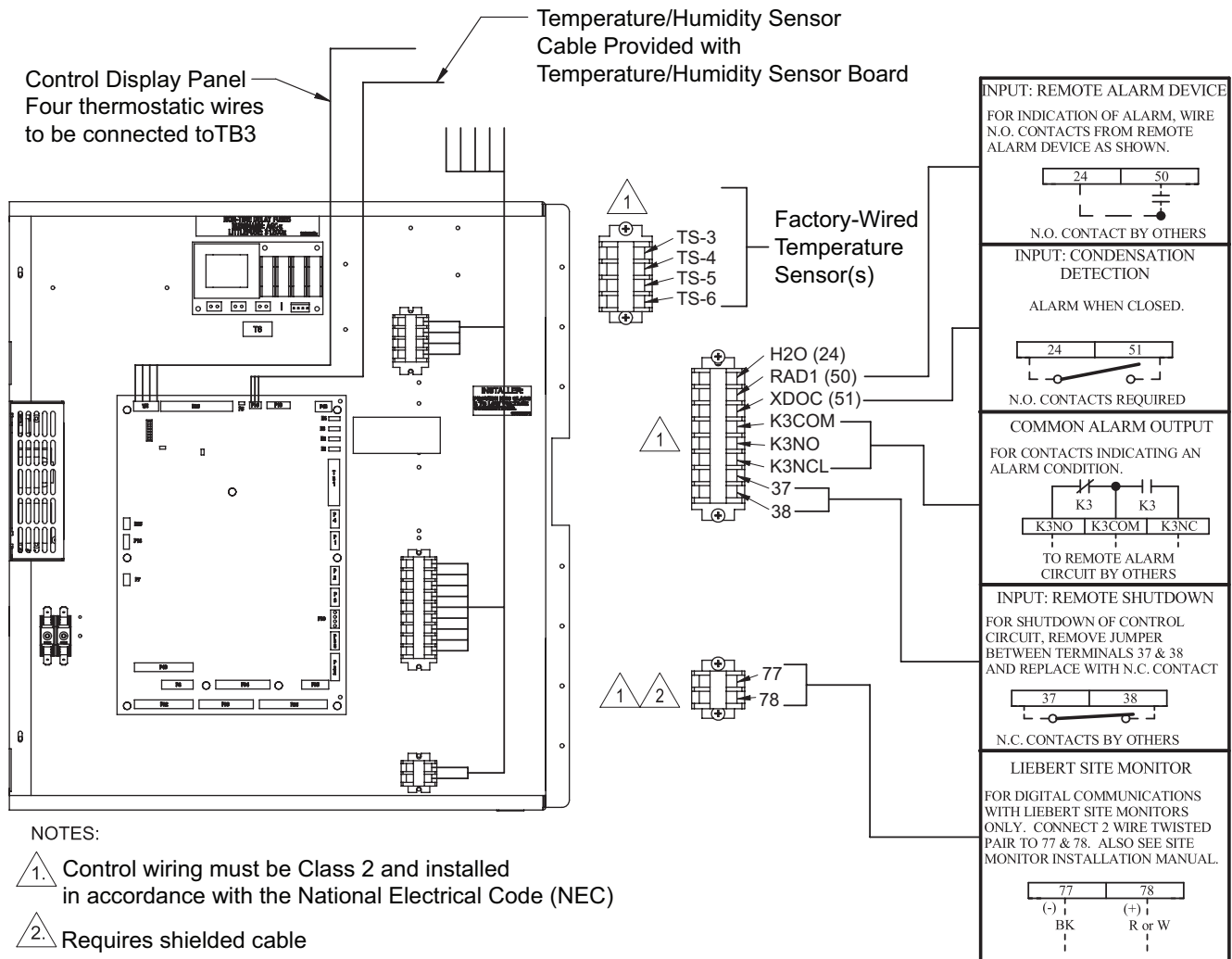

## 2.0 PIPING AND FILLING WITH REFRIGERANT: R-134A AND R-407C CIRCUITS

### 2.1 European Union Fluorinated Greenhouse Gas Requirements

Stationary air conditioning, refrigeration, heat pump equipments and stationary fire protection systems in the European Community market and operating with fluorinated greenhouse gases (f-gas), such as R407C, R134a, R410A, must comply with the F-Gas Regulation: (EC) No. 842/2006 (F-gas). The regulation prohibits, among other actions, venting fluorinated greenhouse gases to the atmosphere.

The F-Gas Regulation requires operators to use all measures that are technically feasible and do not entail disproportionate cost to prevent leakage of these gases, to test for leakage regularly and to recover f-gas before disposing of equipment, as well as during service and maintenance.

Refer to the full regulation for additional details.

### 2.2 Recommended Pipe Size



#### NOTE

*Follow all local codes on maximum length and size of refrigerant lines.*

Connect the main pipes between the Liebert XDC and the Liebert XD cooling modules according to site specific documentation and the configuration guide for the Liebert XD system.

Elbows and restrictions shall be minimized for proper operation.

**Table 4 Supply, return pipe sizes for Liebert XD refrigerant loop**

Pipe Function	Size/Equivalent Pipe Length
Liebert XDC supply line, from Liebert XDC supply to farthest Liebert XD cooling module	1-1/8" OD (1.025" ID) for lengths up to 60 feet
	1-3/8" OD (1.265" ID) for lengths over 60 but less than 175 feet
Liebert XDC return line, from farthest cooling module to Liebert XDC return	2-1/8" OD (1.985" ID) for lengths up to 60 feet
	2-5/8" OD (2.465" ID) for lengths over 60 but less than 175 feet
From any model Liebert XDO/Liebert XDH supply to supply line of Liebert XDC	1/2" OD (0.430" ID) for lengths up to 10 feet
	7/8" OD (0.785" ID) for lengths over 10 but less than 25 feet
From any model Liebert XDO/Liebert XDH return to return line of Liebert XDC	7/8" OD (0.785" ID) for lengths up to 10 feet
	1-1/8" OD (1.025" ID) for lengths over 10 but less than 25 feet
From any model Liebert XDV/Liebert XDCF supply to supply line of Liebert XDC	1/2" OD (0.430" ID) for lengths up to 10 feet
	5/8" OD (0.545" ID) for lengths over 10 but less than 35
From any model Liebert XDV/Liebert XDCF return to return line of Liebert XDC	5/8" OD (0.545" ID) for lengths up to 10 feet
	7/8" OD (0.785" ID) for lengths over 10 but less than 35 feet

### 2.3 Liebert XDC Interconnection With Liebert XD Cooling Module

All piping must be ASTM (American Society for Testing and Materials) Type "L" copper pipe.

The Liebert XDC may be connected to Liebert XD cooling modules with either Liebert's XD prefabricated piping assembly or with rigid, off-the-shelf piping. In either setup, piping for the Liebert XD system is arranged in a manner similar to piping for a chilled water system. Liebert XD cooling modules are connected in parallel between main return and supply pipes going to and from the Liebert XDP/Liebert XDC. **Figure 19** represents a typical configuration. For piping details, refer to Liebert's XD System Design Manual, SL-16655. **The guidelines provided for pipe size must be strictly followed. Failure to size the main lines and connection lines adequately may result in reduced cooling capacity.** The critical aspects of pipe sizing are related to coolant volume and pressure drop. Both must be minimized.

Figure 19 Liebert XD system diagram

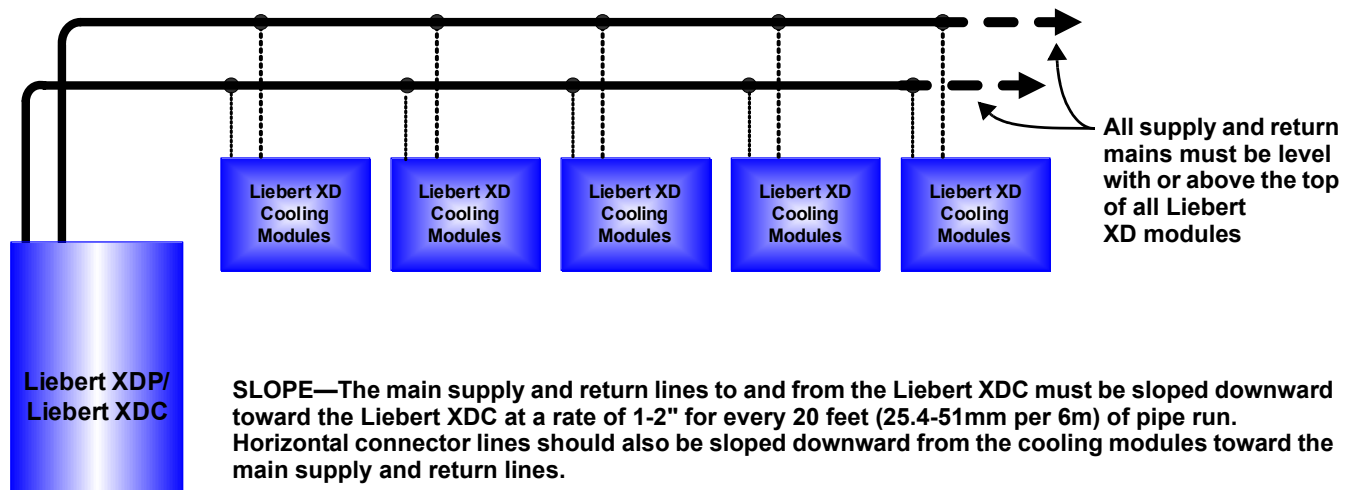

## 2.4 Piping Installation Method

The assembly and connection means used for piping in the Liebert XD system are similar to those used for conventional refrigeration systems. All piping should be installed with high-temperature brazed joints. Soft soldering is not recommended.

During brazing, the lines must be filled with flowing dry nitrogen to prevent excessive oxidation and scale formation inside the piping. Prevailing good refrigeration practices must be employed for piping supports, leak testing, dehydration and charging. Failure to use good system practices may result in damage to the system. Refer to the ASHRAE refrigeration handbook for general good-practice refrigeration piping.

Insulate all piping lines to prevent condensation in applications where the dew point approaches the R-134a refrigerant temperature.

Liebert highly recommends venting the pressure relief valves for both the R-134a and R-407c sides outside the conditioned space where it is open to the atmosphere. The R-134a side relief valve is inside the XDC unit at the top of the receiver. The R-407c water/glycol cooled side relief valves are located at each condenser beneath the XDC unit in the floor stand. The R-407c air cooled relief valves are located outside within the air cooled system.

### 2.4.1 Piping Installation—R-134a Pumped Circuit

Liebert highly recommends venting the relief pressure of the Liebert XDC (located at the top of the receiver) outside of the conditioned space where it is open to the atmosphere.

#### Piping Mains

All refrigeration piping mains connected to the Liebert XD cooling module, both supply and return, should be installed with a downward pitch toward the Liebert XDC of 1-2" for every 20 feet (25.4-51mm per 6m) of pipe run.

### Bypass Flow Controllers

To ensure the Liebert XDC pumps operate within the optimum range, some installations require one or more bypass flow controller(s). These devices are added to the field piping, and simulate the flow of additional cooling modules.

Each bypass flow controller should be installed with one shutoff valve to allow the controller to be disabled when cooling modules are added to a Liebert XD system.

If bypass flow controllers are required, they should be connected between the main supply and the main return lines of the field piping. The connection points to the main supply and return lines should be in a convenient and accessible location between the Liebert XDP/Liebert XDC and the first Liebert XD module in the circuit. See **Figures 20** and **21** for piping details of the bypass flow controller.

Refer to **Table 5** to determine the number of bypass flow controllers needed, based on the total nominal cooling capacity of the cooling modules in each Liebert XD system.

**Table 5** Bypass flow controllers for a Liebert XDC-based system

Cooling Modules - Cumulative Model Size	Required Number of Bypass Flow Controllers
	Liebert XDC
32 to 63	N/A
64 to 95	2
96 to 127	1
128 to 160	0

**Figure 20** Bypass flow controller details, dimensions

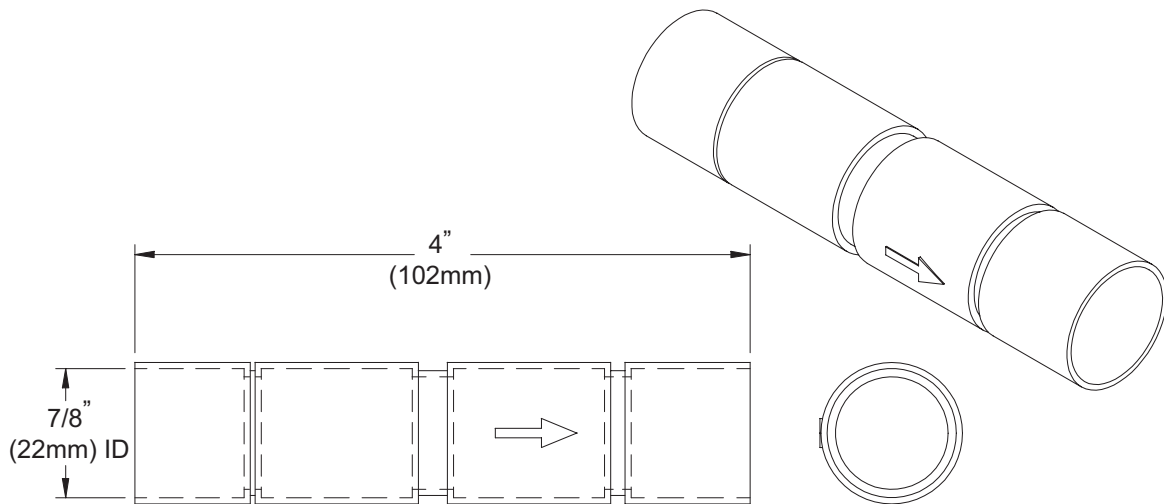

**Figure 21** Bypass flow controller arrangement

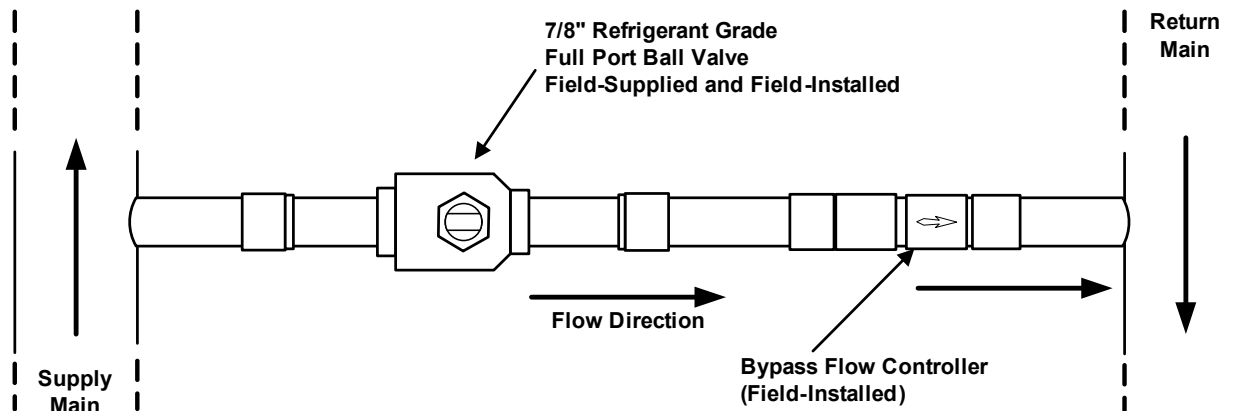
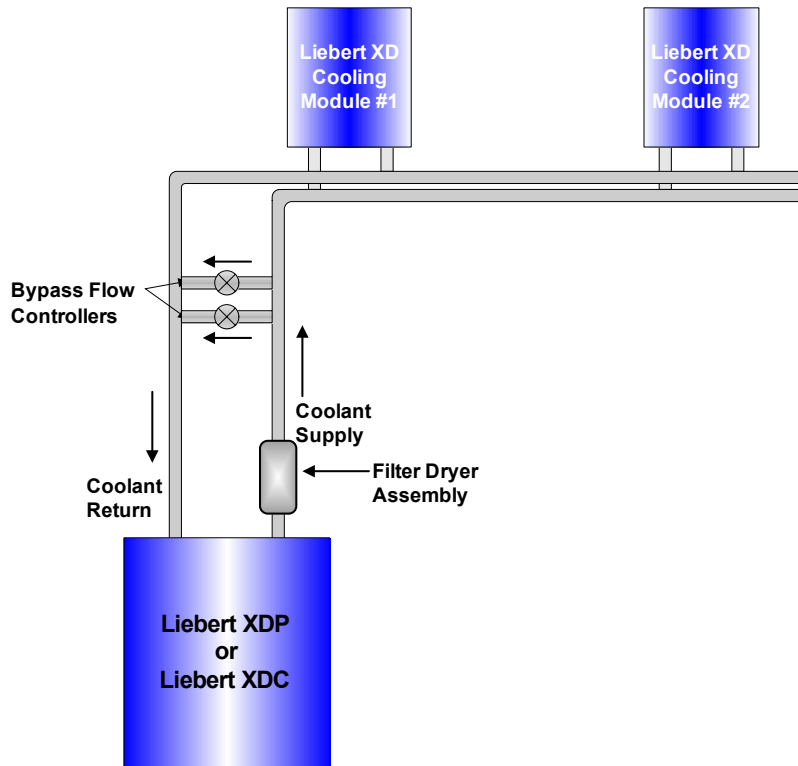



Figure 22 Bypass flow controller piping



### Evacuation and Leak Check—R-134a Pumped Circuit

1. Open all service valves, including those located outside of the Liebert XDC.
2. Place 150 psig (1034kPa; 10.34 bars) of dry nitrogen with a tracer of R-134a in the system.



## CAUTION

Risk of overpressurization. Can cause equipment damage.

Do not exceed 150 psig (1034 kPa; 10.34 bars) in the R-134a circuit.

3. Check the system for leaks with a suitable leak finder
4. After completion of the leak testing, release the test pressure (per local code) and connect to vacuum pump(s) at the Schrader valves.
5. After four hours of pulling a deep vacuum, check the vacuum level and if it has not changed, break the vacuum with dry nitrogen.
6. Pull a second vacuum to 250 microns or less. Recheck the vacuum level after 2 hours.

### Insulation



#### NOTE

*Piping should not be insulated before it has been checked for leaks. Applying good insulation to pipes before checking for leaks would prevent easy detection of leaks.*

Insulate all piping between the Liebert XDC and cooling modules to prevent condensation where the piping passes through non-conditioned areas.

## 2.5 Filling the Pumped Circuit—R-134a

1. Connect a charging manifold to the service port of the receiver outlet valve.
2. Purge the hoses.
3. Calculate the amount of R-134a refrigerant needed to charge the system, using the values in **Tables 6, 7, 8 and 9**; for assistance, refer to **2.5.1 - Calculating Refrigerant Charge—Example**. The section includes a worksheet to calculate system refrigerant charge requirements.
4. Weigh in the calculated charge.
5. After adding the calculated charge, allow the system to sit 15 to 30 minutes to reach equilibrium. Observe the refrigerant level through the sight glasses of the receiver. The level should be above the second sight glass at a minimum when the Liebert XDC is off.
6. If the refrigerant level is improper, the charge must be adjusted.  
If the level is too high or too low, recalculate the required charge and reduce or increase the amount as needed to reach the proper level.



**NOTE**

All lengths in **Tables 7, 8 and 9** are actual pipe lengths, not equivalent pipe lengths.



**NOTE**

System refrigerant volume calculations derived from **Tables 6, 7, 8 and 9** are based on a fully loaded system. Additional charge may be required for lightly loaded systems.

**Table 6 System R-134a charge for a Liebert XDC with any model Liebert XDH/Liebert XDO/Liebert XDV/Liebert XDCF**

Refrigerant Charge, lb (kg)	Per Liebert XD Unit (Excludes Connector Lines to and from Liebert XD Cooling Module)
157 lb. (65.7kg)	Liebert XDC
3.55 lb. (0.66kg)	Liebert XDO
2.32 lb. (1.05kg)	Liebert XDV
5.32 lb. (2.41kg)	Liebert XDH
1.41 lb. (0.64kg)	Liebert XDCF

**Table 7 System refrigerant charge for the supply and return mains**

Refrigerant Charge, lb/foot (kg/m)	Supply/Return Main Length and Diameter
0.45 (0.67)	Main supply actual length per 1-1/8" OD copper tubing
0.68 (1.01)	Main supply actual length per 1-3/8" OD copper tubing
0.28 (0.42)	Main return actual length per 2-1/8" OD copper tubing
0.43 (0.64)	Main return actual length per 2-5/8" OD copper tubing

**Table 8 R-134a refrigerant charge for hard-piped connector lines to and from any model Liebert XDH/Liebert XDO/Liebert XDV/Liebert XDCF**

Refrigerant Charge, lb/foot (kg/m)	Hard-Piped Connector Length and Diameter
0.08 (0.12)	1/2" OD Liebert XDO/Liebert XDH/Liebert XDV/Liebert XDCF supply connector actual length
0.13 (0.19)	5/8" OD copper tubing Liebert XDV/Liebert XDCF supply connector actual length
0.26 (0.39)	7/8" OD Liebert XDO/Liebert XDH supply connector actual length
0.02 (0.03)	5/8" OD copper tubing Liebert XDV/Liebert XDCF return connector actual length
0.04 (0.06)	7/8" OD copper tubing Liebert XDV/Liebert XDCF return connector actual length
0.04 (0.06)	7/8" OD copper tubing Liebert XDH/Liebert XDO return connector actual length
0.07 (0.1)	1-1/8" OD copper tubing Liebert XDH/Liebert XDO return connector actual length

**Table 9 R-134a refrigerant charge for Liebert XD Flex Pipe connector lines to and from any model Liebert XDO/Liebert XDH/Liebert XDV/Liebert XDCF**

Refrigerant Charge, lb. (kg)	Metal Liebert XD Flex Pipe Connector Length
<b>Supply Line Diameter 1/2"</b>	
0.3 lb. (0.14)	4 ft. Liebert XD Flex Pipe Liebert XDH/Liebert XDO/Liebert XDV/Liebert XDCF supply
0.5 lb. (0.23)	6 ft. Liebert XD Flex Pipe Liebert XDH/Liebert XDO/Liebert XDV/Liebert XDCF supply
0.7 lb. (0.32)	8 ft. Liebert XD Flex Pipe Liebert XDH/Liebert XDO/Liebert XDV/Liebert XDCF supply
0.8 lb. (0.36)	10 ft. Liebert XD Flex Pipe Liebert XDH/Liebert XDO/Liebert XDV/Liebert XDCF supply
<b>Return Line Diameter 5/8"</b>	
0.01 lb. (0.01)	4 ft. Liebert XD Flex Pipe existing Liebert XDV systems
0.02 lb. (0.01)	6 ft. Liebert XD Flex Pipe existing Liebert XDV systems
0.03 lb. (0.01)	8 ft. Liebert XD Flex Pipe existing Liebert XDV systems
0.03 lb. (0.01)	10 ft. Liebert XD Flex Pipe existing Liebert XDV systems
<b>Return Line Diameter 1"</b>	
0.13 lb. (0.06)	4 ft Liebert XD Flex Pipe Liebert XDH/Liebert XDO/Liebert XDV/Liebert XDCF supply
0.2 lb. (0.096)	6 ft Liebert XD Flex Pipe Liebert XDH/Liebert XDO/Liebert XDV/Liebert XDCF supply
0.27 lb. (0.126)	8 ft Liebert XD Flex Pipe Liebert XDH/Liebert XDO/Liebert XDV/Liebert XDCF supply
0.33 lb. (0.15)	10 ft Liebert XD Flex Pipe Liebert XDH/Liebert XDO/Liebert XDV/Liebert XDCF supply

**2.5.1 Calculating Refrigerant Charge—Example**

Using **Tables 6, 7, 8 and 9**, calculate the refrigerant charge of the individual sections of your Liebert XD system. Add the calculated charge amounts to determine the amount of R-134a refrigerant required for one system combining a Liebert XDC with Liebert XD cooling modules (Liebert XD Cool-Frame, Liebert XDH, Liebert XDO and Liebert XDV). The example below combines one Liebert XDC with 20 Liebert XDV8 cooling modules.

**Table 10 Calculating refrigerant charge—example**

Components	Number of Units or Piping Length, feet	Pounds Per Component	Total, lb.
Liebert XDC	1	157	157
Liebert XDV8 Cooling Modules	20	2.32	46.4
Supply Main, 1-1/8"	100	0.45	45
Return Main, 2-1/8"	100	0.28	28
Liebert XDV 1/2" supply Liebert XD Flex Pipes	20	0.8	16
Liebert XDV 5/8" return Liebert XD Flex Pipes	20	0.03	0.6
<b>Total</b>			<b>293</b>

**Table 11 Worksheet to calculate refrigerant charge**

Components	Number of Units or Piping Length	Pounds Per Component	Total
<b>Total</b>			

## 2.5.2 Piping for Direct Expansion (DX) Circuit—R-407c Air Cooled Units



### WARNING

Risk of refrigerant system explosion or rupture from overpressurization. Can cause death, injury and equipment damage.

Installer must install a 400 psig pressure relief valve in each of the two R-407c refrigerant circuits of the Liebert XDC system. Do not install shutoff valves between the compressors and the pressure relief valves.

For systems requiring EU CE compliance, the pressure relief valves must be CE-certified by a notified body to the EU Pressure Equipment Directive.

## 2.6 Install Double Discharge Risers

For air-cooled systems, double discharge risers must be installed in the hot gas lines that have vertical heights of 15 feet (4.6m) or more (see **Figure 23**). This will allow proper oil return to the compressors when the system is running at low loads. A double riser system is constructed of a large diameter riser with a trap at the base and a riser with a smaller diameter in parallel.

At full-load operation, the refrigerant vapor flows up both risers at velocities that are adequate to carry the oil. At low loads, refrigerant vapor velocities are lower and the trap at the bottom of the riser becomes filled with oil. When this happens, refrigerant flows up only the smaller riser.

The trap at the top of the riser must be tied into the top of the line to prevent oil from filling the larger riser. For each double riser used, the maximum height of the riser must not exceed 15 feet (4.6m). Multiple risers must be installed in series as the height of the hot gas line increases. Total maximum height of the hot gas line must not exceed 60 feet (18.3m).

Horizontal discharge lines should be pitched downward in the direction of flow to aid in oil drainage with downward pitch of at least 1/2 inch in 10 feet (13mm in 3m).

**Figure 23** Double discharge riser layout

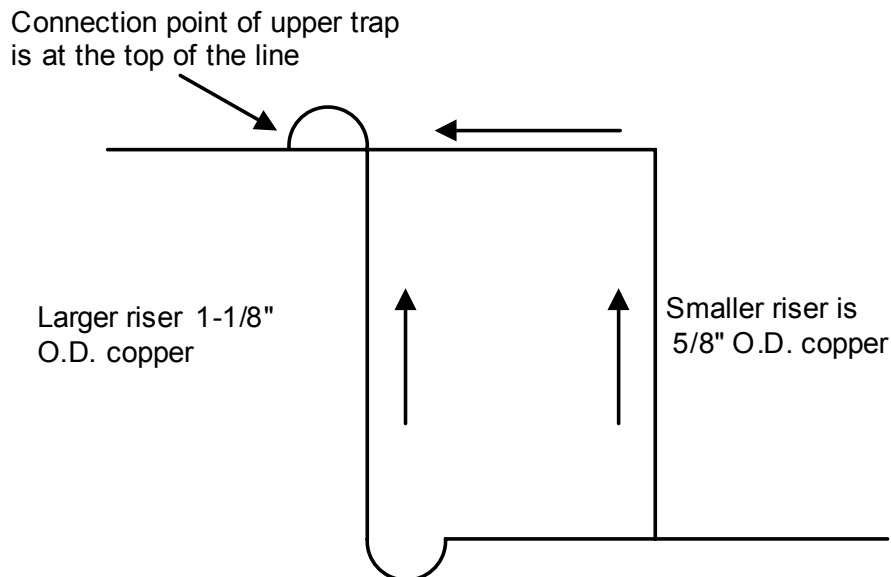

Trap size is 1-1/8" large riser size with minimum internal

Contact your local Liebert representative for factory approval whenever a refrigerant piping run exceeds 200 feet (60m) equivalent length or when condensers must be installed below the level of the cooling coil.

**For Air Cooled Lee-Temp / Flood Back Head Pressure Control Units Only**



**NOTE**

*Proper safety equipment and proper refrigeration tools are required. Check unit nameplate for correct refrigerant type before topping off or recharging a system.*



**NOTE**

*Refrigerant R-407c is a blend of three components and must be introduced and charged from the cylinder only as a liquid.*

*Refrigerant R-407c uses a POE (polyolester) lubricant. Do not open the compressor unit piping to the atmosphere for more than 15 minutes. The compressors contain POE oil that is very hygroscopic; it quickly absorbs water from the atmosphere. The longer the compressor piping is open to the atmosphere, the harder it will be to fully evacuate. If left open too long, the POE oil may need to be replaced before achieving the required vacuum level.*

*POE oils also have a property that makes them act as a solvent in a refrigeration system. Maintaining system cleanliness is extremely important because the oil will tend to bring any foreign matter back to the compressor. Refer to the ASHRAE refrigeration handbook for general good-practice refrigeration piping.*

Figure 24 Installation data—Lee-Temp, one-circuit, four-fan model

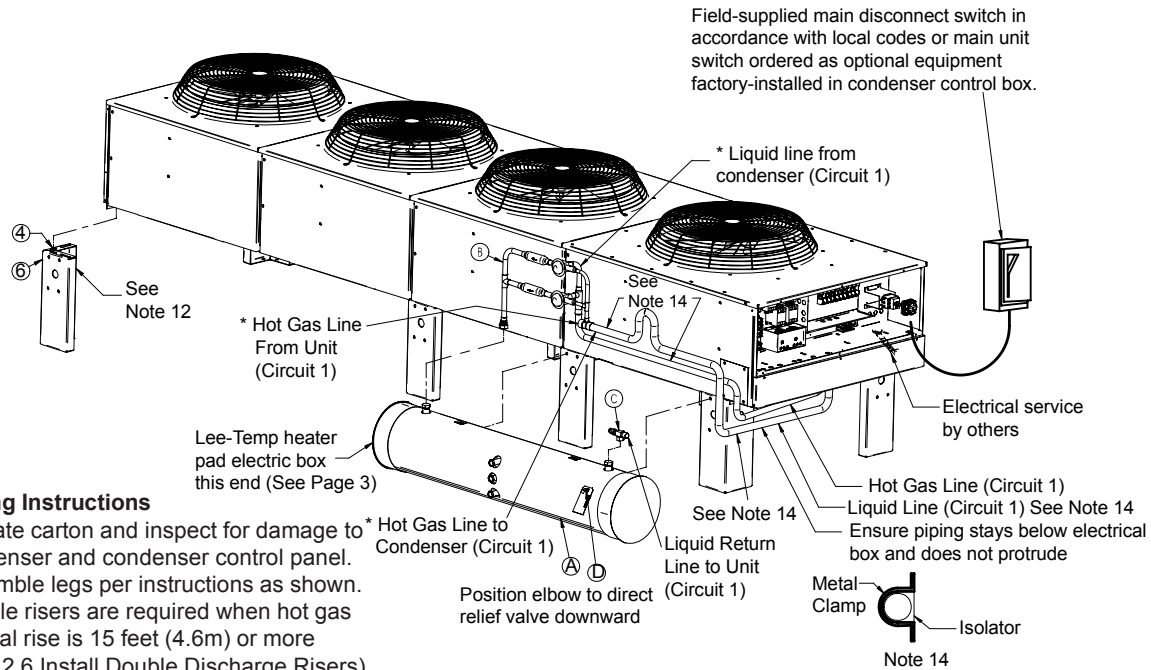

**Mounting Instructions**

1. Uncrate carton and inspect for damage to condenser and condenser control panel.
2. Assemble legs per instructions as shown.
3. Double risers are required when hot gas vertical rise is 15 feet (4.6m) or more (see 2.6 Install Double Discharge Risers).
4. Wire according to electrical diagram on inside of condenser control box and in accordance with all local codes.
5. All condenser locations more than 200ft. (61m) of equivalent piping length away from Liebert XDC must consult factory for special piping considerations.
6. Field to size refrigerant lines so as not to exceed 2°F (1.1°C) saturation loss for total equivalent length (do not use connection sizes to determine line sizes).
7. Condenser installation is limited to a maximum of 15ft. (4.6m) location below Liebert XDC unit.
8. Do not run piping or wiring in the path of air flow because this will reduce system performance.
9. Install field-supplied inverted traps on hot gas lines between condenser and field piping.
10. All other piping field-supplied and field-connected.
11. Inverted traps must be installed to allow proper clearance to fully open condenser control box door and in accordance with local electric codes.
12. Secure Lee-Temp receiver assembly and each leg to condenser frame using hardware provided. Receiver can be mounted on either side of the condenser.
13. Lee-Temp Item B is shipped as a pre-piped assembly shipped loose for field installation. Item C is shipped loose for field installation.
14. Fasten liquid and hot gas lines using flat surface clamps with isolators (field-provided). Support field piping separately to avoid coil damage and loss of charge
15. Relieve pressure at access port. Replace access port fitting with relief valve before charging system.

**MATERIALS SUPPLIED BY EMERSON NETWORK POWER**

- ① Built-in condenser control box. See electrical drawing □ for details and field wiring.
- ② Air-cooled condenser.
- ③ Piping access cover to be reinstalled when piping is completed.
- ④ Bolts - (4 per leg) 3/8" (9.5mm) - (16) sixteen 5/8" (15.9mm)
- ⑤ Terminal block for two-wire, 24V interlock connection between □ Liebert XDC and Liebert condenser.
- ⑥ Condenser legs - (8) eight legs for (4) four-fan models.
- ⑦ Lee-temp:
  - a. Insulated storage receiver - storage receiver (1) per circuit. 5-foot-long receiver is standard.
  - b. Dual head pressure control valve assembly with integral check valve(s) - (1) one per circuit (See Note 13)
  - c. Rotalock valve - (1) one per circuit
  - d. Pressure relief valve - (1) one per circuit, field-installed.
  - e. Liquid level indicator - (1) per circuit, factory-installed on receiver
- ⑧ Bolts - Lee-Temp 3/8" (9.5mm)

DPN000937  
Pg. 01, Rev. 09

**For CSL616 condenser piping connections, see Figures 28 and 29.**

Figure 25 Installation data—Lee-Temp, one-circuit, high ambient six-fan model

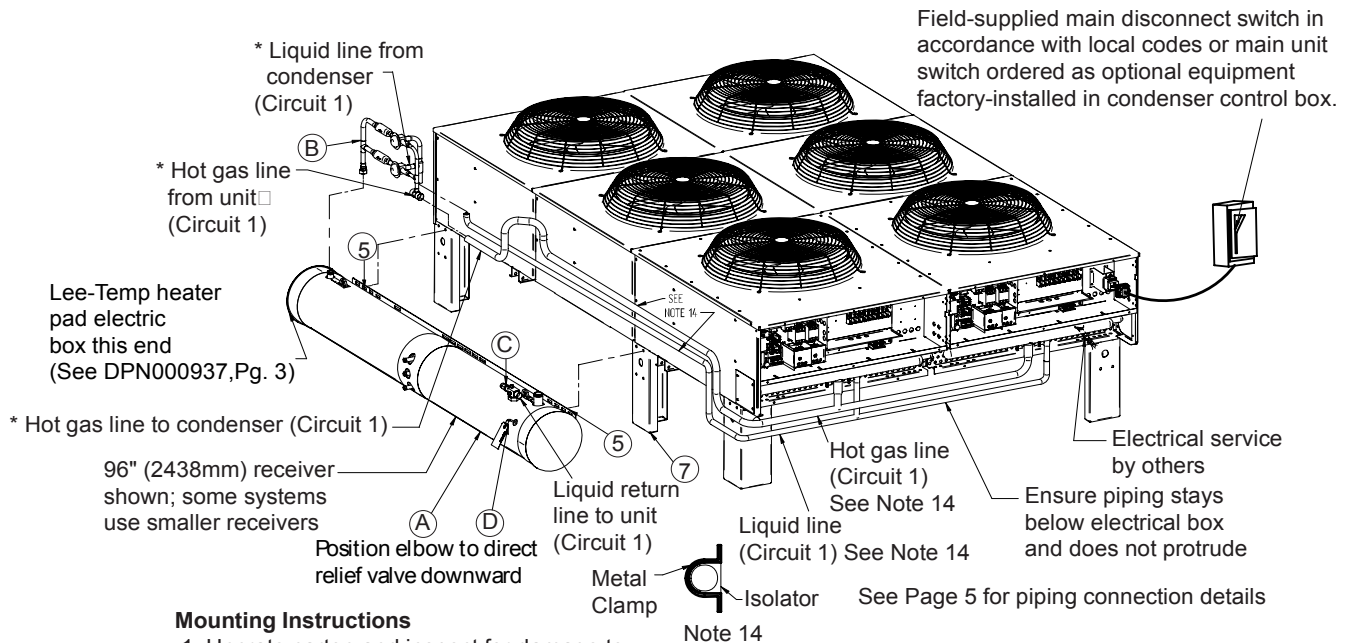

**Mounting Instructions**

1. Uncrate carton and inspect for damage to condenser and condenser control panel.
2. Assemble legs per instructions as shown.
3. When piping long, vertical rises, oil traps are recommended on hot gas line every 25 ft. (7.6m) (see 2.6 Install Double Discharge Risers).
4. Wire according to electrical diagram on inside of condenser control box and in accordance with all local codes.
5. All condenser locations more than 200 ft. (61m) of equivalent piping length away from Liebert XDC unit must consult factory for special piping considerations.
6. Field to size refrigerant lines so as not to exceed 2°F (1.1°C) saturation loss for total equivalent length (do not use connection sizes to determine line sizes).
7. Condenser installation is limited to a maximum of 15 ft. (4.6m) location below Liebert XDC unit.
8. Do not run piping or wiring in the path of air flow as this will hamper the system performance.
9. Install field-supplied inverted traps on hot gas lines between condenser and field piping.
10. All other piping field-supplied and field-connected.
11. Inverted traps must be installed to allow proper clearance to fully open condenser control box door and in accordance with local electric codes.
12. Secure Lee-Temp receiver assembly and each leg to condenser frame using hardware provided. Receiver can be mounted on either side of condenser.
13. Lee-Temp Item B is shipped as a pre-piped assembly shipped loose for field installation. Item C is shipped loose for field installation.
14. Fasten liquid and hot gas lines using flat surface clamps with isolators (field provided). Support field piping separately to avoid coil damage and loss of charge.
15. Relieve pressure at access port. Replace access port fitting with relief valve before charging system.

**Materials Supplied by Liebert**

- 1 Built-in condenser control box. See electrical drawing for details and field wiring.
- 2 Air-cooled condenser.
- 3 Piping access cover to be reinstalled when piping is
- 4 3/8"-16 x 3/4" long bolts - (20 total) attaches legs to condenser frame.
- 5 3/8"-16 x 1-1/4" long bolts - (10 total) attaches legs to receiver. 3/8" nuts (10 total). 3/8" washers (20 total)
- 6 Terminal block for 2 wire 24 volt interlock connector Liebert XDC unit and Liebert condenser.
- 7 Condenser legs - (5) fivelegs for (6) six-fan models.
- 8 Lee-Temp:
  - a. Insulated storage receiver - storage receiver (1) per circuit. Receiver size varies.
  - b. Dual head pressure control valve assembly with integral check valve(s) - (1) one per circuit (S)
  - c. Rotalock valve - (1) one per circuit, field-installed.
  - d. Pressure relief valve - (1) one per circuit, field-inst
  - e. Liquid level indicator - (1) per circuit factory-installed on receiver.

DPN000937  
Pg. 02, Rev. 09

See Figure 29 for details on piping connections.

Figure 26 Liebert XDC piping schematic and Lee-Temp heater pad wiring

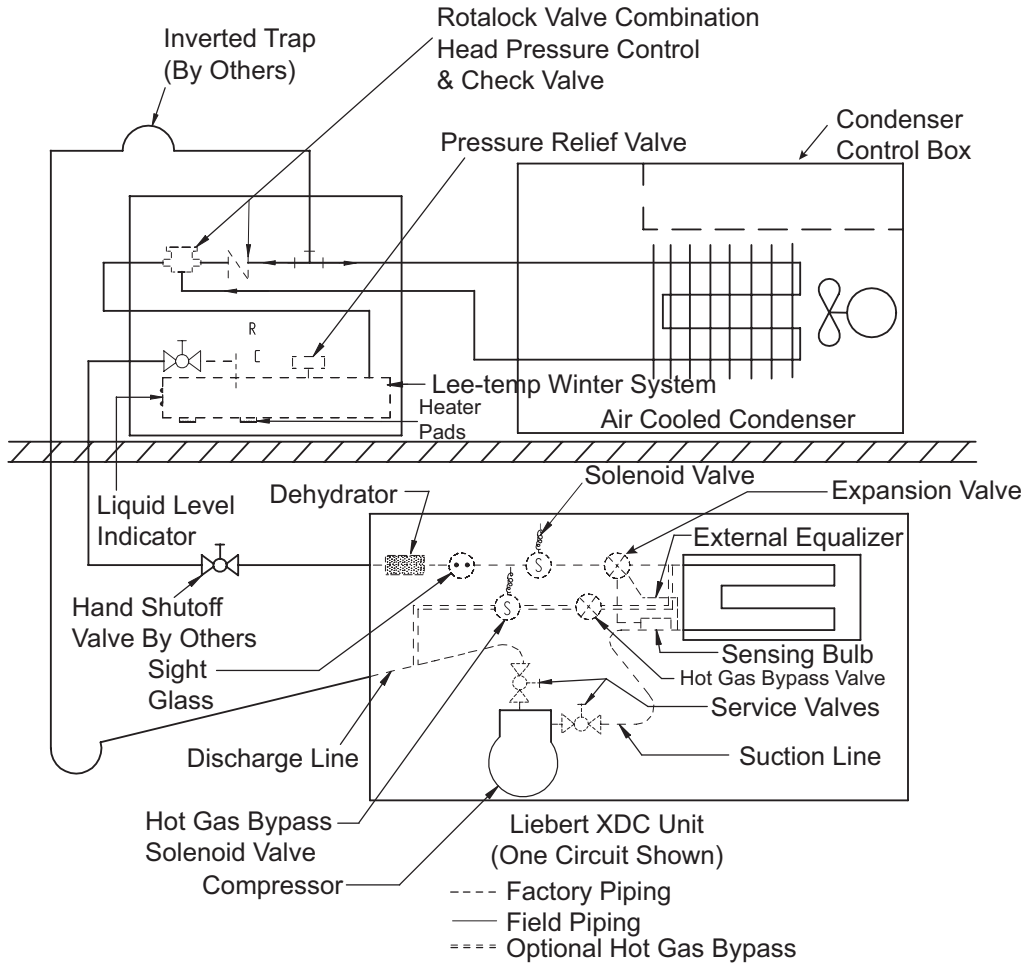

**Piping Schematic**

Circuit 1 & 2 Standard Model With 2 Heater Pads Per Receiver Hi Limit Thermostat Typical

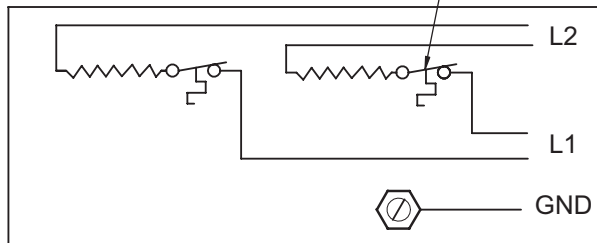

Circuit 1 & 2 Optional Model With 3 Heater Pads Per Receiver

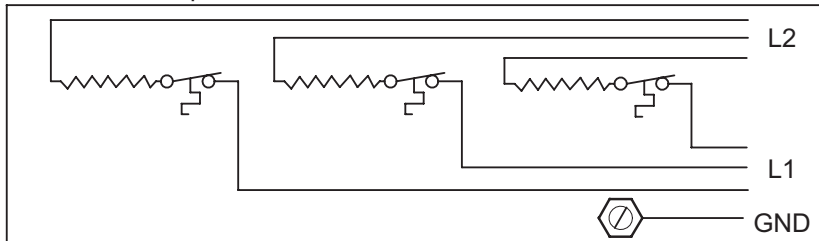

Separate Continuous Electrical Source By Others

- Volts
- 115
  - 200/208/230

Total Watts Per Receiver

- Standard 300 Watt (2 Heater Pads)
- Optional 450 Watt (3 Heater Pads)

1 Phase 50/60 Hz

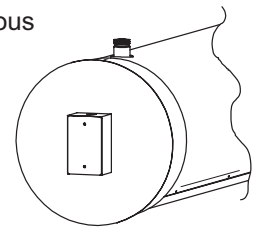

**Lee-Temp Heater Pad Wiring**

DPN000937  
Pg. 3, Rev. 6



Figure 27 General arrangement air cooled Liebert XDC Lee-Temp Control

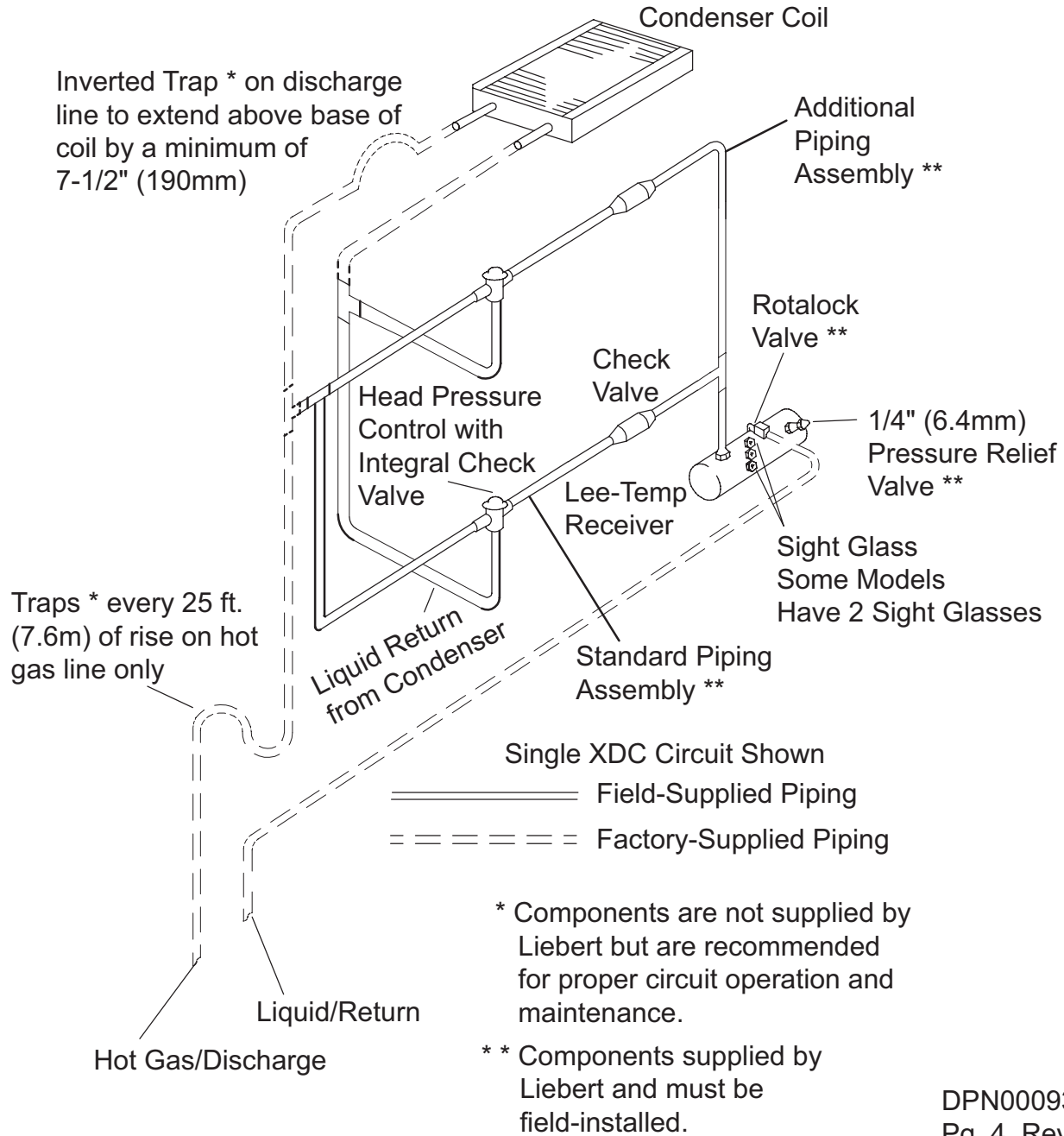

DPN000937  
Pg. 4, Rev 9

Table 12 Recommended refrigerant line sizes, DX R-407c, OD copper

Liebert XDC 160		
Equivalent Length, ft., (m)	*Hot Gas Line, in.	Liquid Line, in.
50 (15)	1-1/8	7/8
100 (30)	1-1/8	1-1/8
150 (45)	1-3/8	1-1/8
200 (60)	1-3/8	1-1/8

\* Double risers are required when hot gas vertical rise is 15 feet or more (see 2.6 - Install Double Discharge Risers).

Figure 28 DCSL616 piping connections—two refrigerant circuits connected for parallel flow

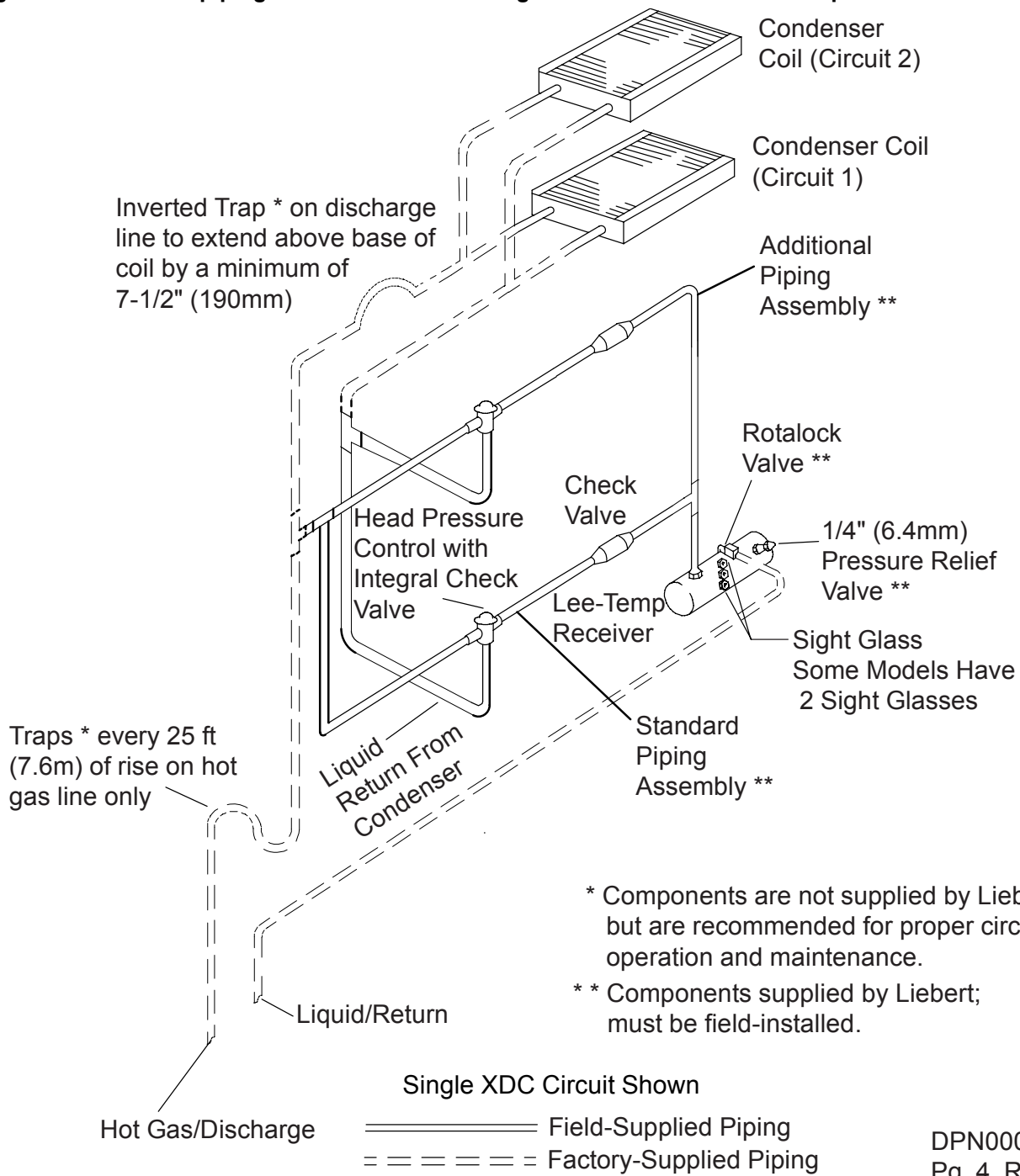

DPN000937  
Pg. 4, Rev 9

Table 13 Recommended refrigerant line sizes for DCSL616

Liebert XDC 160		
Equivalent Length, ft., (m)	*Hot Gas Line, in.	Liquid Line, in.
50 (15)	1-1/8	7/8
100 (30)	1-1/8	1-1/8
150 (45)	1-3/8	1-1/8
200 (60)	1-3/8	1-1/8

\* Double risers are required when hot gas vertical rise is 15 feet or more (see 2.6 - Install Double Discharge Risers).

Figure 29 CSL616 piping connections—two refrigerant circuits connected for parallel refrigerant flow

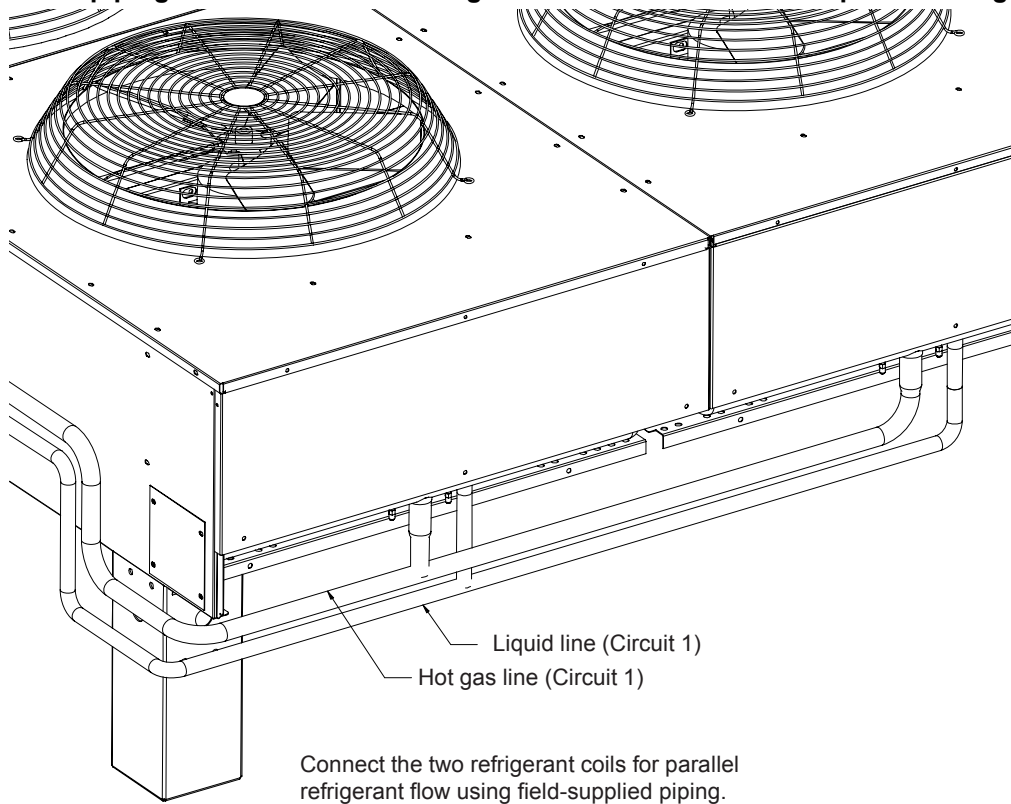

Refrigerant lines are to be routed and secured to prevent excessive vibration and stress at the connections.

DPN000937  
Pg. 5, Rev. 9

**For mounting instructions, refer to Figure 25.**

### 2.6.1 Air Cooled Condenser with Lee-Temp “Flooded Condenser” Head Pressure Control System—R-407c (DX) Circuit

The Lee-Temp system consists of a modulating type head pressure control valves and insulated receivers with heater pads to ensure operation at ambient temperatures as low as -30°F (-34.4°C).

#### Lee-Temp Piping

Two discharge lines and two liquid lines must be field-installed between the indoor unit and the outdoor condenser. See **Figures 24** and **27** for details.

#### Lee-Temp Control Materials Supplied

- Built-in, pre-wired condenser control box
- Air cooled condenser
- Piping access cover to be reinstalled when piping is complete
- Bolts—four per leg (3/8" x 5/8")
- Terminal block for two-wire, 24V interlock connection between unit and condenser
- Condensate legs—four with one-fan, six on two-and three-fan models and eight on four-fan models
- Bolts—used to mount receiver (3/8" x 1-1/4")
- Lee-Temp system:
  - Insulated storage receiver—one per circuit
  - Head pressure control assembly (head pressure valves and check valves) - one per circuit
  - Service valve—one per circuit
  - Pressure relief valve—one per circuit
  - Liquid level sight glasses



#### NOTE

*Lee-Temp heater pads require a separate, continuous electrical source. See nameplate on unit for proper voltage.*

#### Evacuation and Leak Check—R-407c (DX) Circuit (Air and Water/Glycol Systems)

1. Make sure the unit is Off. Open all disconnects and pull all fuses except the control fuses. On units supplied with circuit breakers, open all breakers except for the transformer.
2. Energize the liquid line solenoid valves via 24VAC or through Diagnostics under “Test Outputs,” select DEHYDRATION to be On (see **5.3.17 - DIAGNOSTICS**). This will energize the solenoids and hot gas valves to open simultaneously on Circuit 1 and Circuit 2.



#### NOTE

*The procedures above allow the technician to use 24VAC power and controls to open liquid line solenoid valve(s) for the dehydration process. If no power is at the unit disconnect, the technician is to use a separate 24VAC source rated at 75 VA and connect to the system liquid line solenoid valve(s) directly.*

3. Attach refrigerant gauges to the suction and discharge service valves of the compressor.
4. Open all compressor service valves, including those located outside the Liebert XDC.
5. Connect the tank of dry nitrogen to the Schrader valves on the liquid lines and the hot gas lines.
6. Pressurize the system circuit(s) to 150 PSIG (1034 kPa; 10.34 bars) with dry nitrogen with a trace of refrigerant. Check the system for leaks with a suitable leak finder.
7. After completion of leak testing, release the test pressure (per local code) and connect to vacuum pump(s) at the Schrader valves on the liquid lines and on the hot gas lines.
8. After 4 hours of pulling a deep vacuum, check the vacuum levels and, if they have not changed, break the vacuum with dry nitrogen.
9. Pull a second and third vacuum to 250 microns or less. Recheck the vacuum level after 2 hours.

## 2.7 Filling the Direct Expansion (DX) Circuit—R-407c



**NOTE**

If necessary, refer to **3.0 - Installation Checklist** to ensure that the system has been properly checked out and is ready to be filled with coolant.

Any recommended volumes will be approximate. The user must verify that all circuits of the system have been adequately filled.

### For Air Cooled Lee-Temp / Flood Back Head Pressure Control Units Only



**NOTE**

Proper safety equipment and proper refrigeration tools are required. Check unit nameplate for correct refrigerant type before topping off or recharging a system.



**NOTE**

Refrigerant R-407c is a blend of three components, and must be introduced and charged from the cylinder only as a liquid.

Refrigerant R-407c uses a POE (polyolester) lubricant. Do not open the compressor unit piping to the atmosphere for more than 15 minutes. The compressors contain POE oil that is very hygroscopic; it quickly absorbs water from the atmosphere. The longer the compressor piping is left open to the atmosphere, the harder it will be to fully evacuate. If left open too long, the POE oil may need to be replaced before achieving the required vacuum level.

1. Make sure the Liebert XDC is Off.
2. Connect the refrigerant gauge charging hose to the refrigerant drum and to the receiver at the rotalock valve and/or to the Schrader valves on the liquid lines.
3. Weigh in the calculated charge based on **Tables 14, 15, 16 and 17**—values are maximum, based on outdoor air temperature of -30°F (-34°C).
4. Open the rotalock valve and fill the complete calculated charge.

**Table 14 Indoor unit refrigerant charge—R-407c**

Model 50/60 Hz	Charge/Circuit, lb. (kg)
Liebert XDC160	17.5 (8.0)

**Table 15 Outdoor air condenser charge—R-407c**

Outdoor Ambient, °F (°C)	Model 50/60 Hz	Charge / Circuit, lb (kg)
-30 to 95 (-34 to 35)	CDL830 or CSL415	200 (90.8)
-30 to 100 (-34 to 38)	CDL830 or CSL415	200 (90.8)
-30 to 105 (-34 to 41)	CSL616	254 (115.2)
35 to 105 (2 to 41)	CSL616	164 (74.5)

**Table 16 Air cooled systems - liquid line charge - R-407c refrigerant per 100 ft (30 m) of Type "L" copper tube**

O.D., inches	Liquid Line, lb (kg)	Hot Gas Line, lb (kg)
3/8	3.7 (1.7)	-
1/2	6.9 (3.1)	-
5/8	11.0 (5.0)	2.2 (1.0)
3/4	15.7 (7.1)	3.1 (1.4)
7/8	23.0 (10.4)	4.5 (2.0)
1-1/8	39.3 (17.8)	7.8 (3.5)
1-3/8	59.8 (27.1)	11.8 (5.4)
1-5/8	-	16.7 (7.6)

**Table 17 Indoor water/glycol cooled module – R-407C refrigerant charge**

Model 60 Hz	Charge / Circuit, lb(kg)
Liebert XDC 160	30.0 (13.2) per circuit

### 3.0 INSTALLATION CHECKLIST

---

- 1. Unpack and check received material.
- 2. Position Liebert XDC and secure to floor.
- 3. Wire high voltage connections.
- 4. Wire low voltage connections.
- 5. Connect Liebert XD cooling module piping to Liebert XDC.
- 6. Check all circuits of the system for leaks.
- 7. Hold a vacuum on all circuits of the system.
- 8. Charge the system with refrigerant.
- 9. Make sure that all piping has proper insulation.
- 10. Use double risers in DX hot gas lines that are 15 feet (4.6m) or more in height.

## 4.0 CHECKLIST FOR LIEBERT XDC STARTUP



### WARNING

Risk of piping and component rupture. May cause injury or equipment damage. Closing service valves may isolate liquid refrigerant, causing high pressure and rupture of piping. Do not close valves without following recommended procedures for repair, maintenance and replacement of components. Install pressure relief valves in field piping that may become isolated by service valves.



### NOTE

Before any action that could cause a disturbance in the Liebert XD system's cooling function is begun, the facility manager **MUST** be informed. In addition, after the action is taken and the work is finished, the facility manager **MUST** be informed.

1. Verify that bypass flow controllers were installed (if applicable), see **Table 5**:
2. Check all isolation ball valves in the Liebert XDC and Liebert XD cooling module and verify that all are open.
3. Check rotation of Liebert XDC pumps.  
Use the rotation device provided—this device must be held against the pump housing—at the inspection screw prior to energizing the pumps—Green indicates proper rotation; Green and Red indicate incorrect rotation.

**Table 18 Liebert XDC pump light indicator \***

Indicator Lights		Description
Green	Red	
Off	Off	The electricity supply has been switched off or the pump has been cut out by the thermal switch.
On	Off	The electricity supply has been switched on. Normal operation.
On	On	The electricity supply has been switched on. The direction of rotation is <b>wrong</b> .

\* Use the rotation tester provided with the Liebert XDC for 460V models

4. Check rotation of fans on Liebert XD cooling modules.
5. Verify that air is being discharged in the “cold aisle.”
6. Check rotation of fans on condenser(s) of Liebert XDC (air cooled units only)—Verify that air is being discharged out to the atmosphere.
7. Confirm that the total calculated refrigerant R-134a amount has been properly charged into the system [see **2.5 - Filling the Pumped Circuit—R-134a**].
8. Confirm that the total calculated refrigerant R-407c amount has been properly charged into the system (see **2.7 - Filling the Direct Expansion (DX) Circuit—R-407c**).
9. Confirm that the remote temperature/humidity sensor provided has been installed in the correct location.

The correct location is near the return side of a main air mover such as a Liebert Deluxe System 3. If more than one Liebert XDC is installed, use a different location for each remote sensor for best temperature/humidity calculation.

### 4.1 System Refrigerant Charges Over 35 lb. (15.9kg) Require Additional Oil

System charges over 35 lb. (15.9kg) require additional oil charge to be added. See **Figure 30** for the amount required for various charge levels.

Once the system has been fully charged with refrigerant, use a hand pump to add the additional oil at the suction side of the system while the system is running.

The amount of oil added by field service must be recorded on a tag attached at the tandem the amount added along with the date it was added. This will be documented on a tag located at the tandem compressor and marked "Oil Added Field Service Record."

**Figure 30 Additional oil requirements for refrigerant charge**

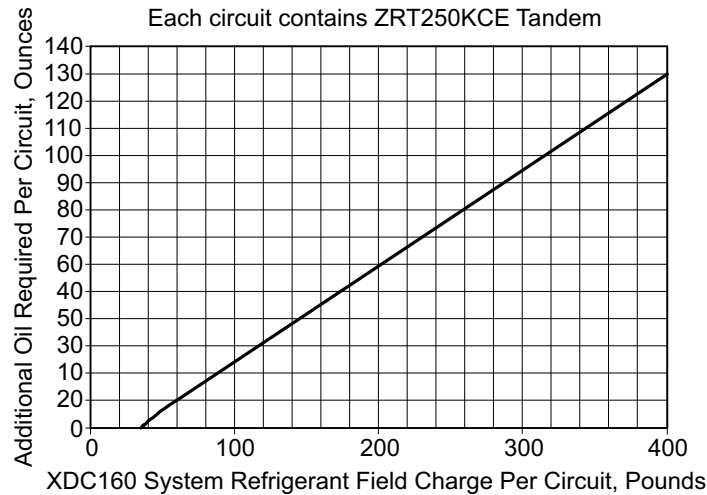

## CAUTION

Risk of improper compressor lubrication. Can cause compressor and refrigerant system damage.

Failure to use oil types, viscosities and quantities recommended by the compressor manufacturer may reduce compressor life and void the compressor warranty. See oil types specified in **Table 19**.

- Do not mix polyolester (POE) and mineral-based oils.
- Do not mix oils of different viscosities.

Consult Emerson or the compressor manufacturer if questions arise.

**Table 19 Compressor oil types**

Compressor Type	Refrigerant Type	
	R-22	R-407c
Carlyle Semi-Hermetic	Mineral Oil	POE OIL - ISO 68 Viscosity
Copeland Scroll and Digital Scroll	POE OIL - ISO 32 Viscosity	

1. Use Carlyle Mineral Oil Totaline P903-2001, Witco Suniso 3GS or other Carlyle-approved oil.
2. Use Carlyle POE Totaline P903-1001, Castrol SW68 or other Carlyle-approved oil.
3. Use Copeland® POE Oil ULTRA 22CC, Mobil EAL Arctic 22CC, Copeland brand Ultra 22 CC, Copeland brand Ultra 32 CC, Copeland brand Ultra 32-3MAF, Mobil EAL™ Arctic 22 CC or Uniqema RL32-3MAF or other Copeland-approved oil.



**The Liebert XDC system is now ready to be turned ON.**

1. Turn On all fans of the Liebert XD cooling modules.
2. Turn the Liebert XDC On via user interface (I/O button). Allow the system to attempt to start for at least 2 minutes.

If the Liebert XDC pump cannot maintain flow and continues to switch over due to starting difficulties, proceed to **Step 4** and refer to the troubleshooting section of the Liebert XDC user manual.

3. If constant flow is established, wait until the Liebert XDC has been operating 10-15 minutes, then verify that the refrigerant level in the receiver sight glass is between the second and third level (see **Figure 31**). Add or remove charge as indicated by sight glass level.
4. Check pressure differential functionality:

The Liebert XDC system should be On. If it is Off:

- a. Turn On the Liebert XD cooling module fans
- b. Turn the Liebert XDC On via user interface (I/O button).

**If there is no “Loss of Flow” alarm present**—This suggests that there is flow. Test the pressure differential by closing the ball valve on either the suction line or discharge line to stop the flow.

This should prompt an alarm for “loss of flow on P1.” This alarm confirms that the switch has opened on low pressure (below 6 psi; 41 kPa; 0.41 bars).

**If there is a “Loss of Flow” alarm present**—This suggests that there is no flow. Verify that this is correctly annunciated by looking at the sight glass in the receiver. If a true no-flow condition exists, the level will not move.

However, **if there is flow, but the differential reading is faulty**, the level will slowly drop, indicating flow, while the loss of flow alarm is annunciated.

Check the pressure differential physically by making sure that the electrical connections are properly connected. Then check the pressure differential electrically by making sure that the unit has 24VAC across it.

**Figure 31 System R-134a liquid level**

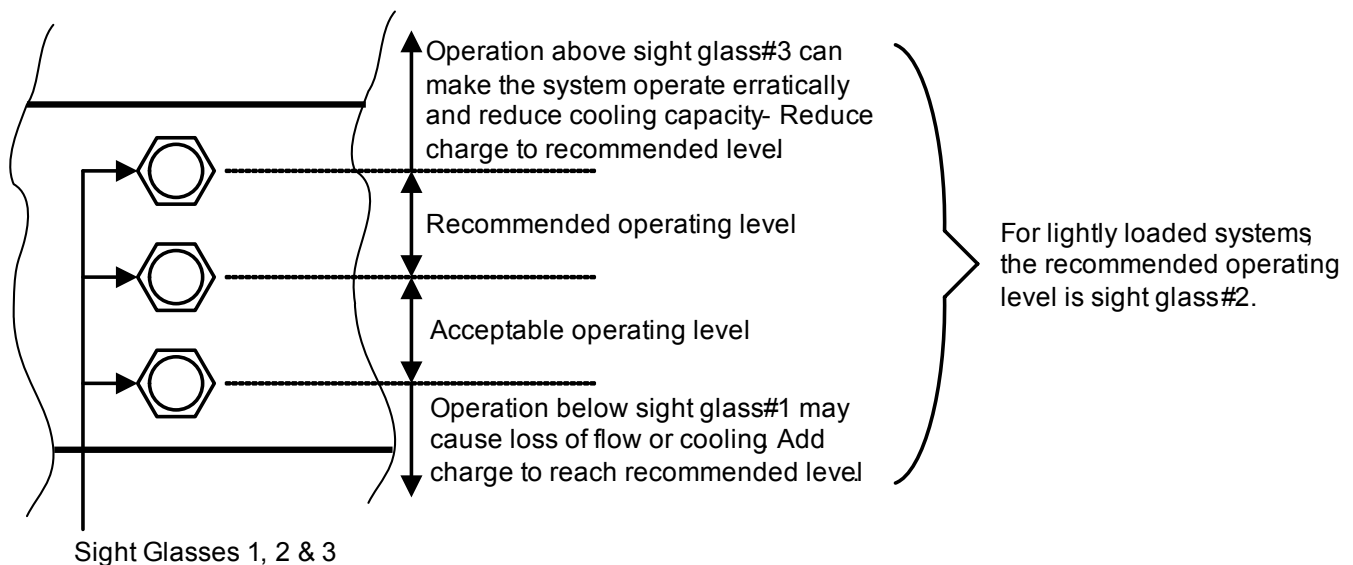

## 5.0 MICROPROCESSOR CONTROL

### 5.1 Feature Overview

The microprocessor control for the Liebert XDC unit features an easy-to-use menu-driven LCD. The menu, control features and circuit board details are described in this section.

**Figure 32 User interface**



Active alarms are displayed on the LCD screen and sound an audible beep. To silence an alarm, press the Alarm Silence/Help key as prompted on the display.

Setpoints, DIP switch settings and other selections were made during factory testing of the unit based on typical operating conditions. (Other default selections were made according to options included with the unit.)

**ADJUST THE FACTORY DEFAULTS ONLY IF THEY DO NOT MEET YOUR SPECIFICATIONS.**

Allowable ranges are displayed by pressing the Help key. A password will be required (if enabled) to change setpoints, time delays, etc.

The display normally shown includes the present room temperature, humidity, active status functions and active alarms. More detailed status and alarm information is available from the menu.

#### 5.1.1 Display

To turn the unit On, press the On/Off (I/O) key after power is applied to the Liebert XDC.

To turn the unit Off, press the On/Off (I/O) key before power is disconnected.

**Table 20 User interface keypad functions**

Keypad	Function
<b>On/Off (I/O)</b>	Turns the unit On or Off (top far left keypad)
<b>Menu</b>	Enables the user to access the program menu to change setpoints, alarms, etc. (top near left)
<b>Up Arrow Key</b>	Raises the value of displayed parameter while in a set mode (set points, time, etc).(arrow, top near right)
<b>Escape (Esc)</b>	Allows user to move back to a previous menu (top far right)
<b>Alarm Silence</b>	If an alarm is present, press this key to silence the alarm. Help text will appear if this key is pressed when no alarm is present (bottom left)
<b>Down Arrow Key</b>	Lowers the value of displayed parameter while in a set mode (set points, time, etc).(arrow, bottom near right).
<b>Enter</b>	After setting a control value, press ENTER to store the information in the microprocessor (bottom right).

## 5.2 Controls

The Microprocessor Control for the Liebert XDC features an easy-to-use, menu-driven liquid crystal display. The menus, control features and circuit board details are described in this section.

### 5.2.1 Feature Overview

The Liebert XDC maintains the coolant being pumped to Liebert XD cooling modules at a temperature above the room dew point, preventing condensation.

### 5.2.2 Status Display

The display normally shows the leaving refrigerant temperature on the first line and alternates between the dew point and the number of alarms present on the second line.

## 5.3 Main Menu

Press the MENU key to display the Main Menu. The menu selections are:

- SETPOINTS
- STATUS
- ACTIVE ALARMS
- ALARM HISTORY
- TIME
- DATE
- SETUP OPERATION
- SETPT PASSWORD
- SERVICE PASSWORD
- CALIBRATE SENSOR
- ALARM ENABLE
- ALARM TIME DELAY
- COMMON ALARM ENABLE
- CUSTOM ALARMS
- CUSTOM TEXT
- DIAGNOSTICS
- END OF MENU

### 5.3.1 Viewing or Changing Settings

To access a menu option:

1. Use the up or down arrow key to scroll to the menu option.
2. Press the ENTER button to view the current setting.
3. To change the setting, use the up or down arrow key.
4. Press ENTER to save the change.

## 5.3.2 SETPOINTS

Selecting SETPOINTS from the Main Menu will reveal the following menu items:

**Table 21 Setpoint functions, default values and allowable ranges**

Menu Item	Function	Default	Range
MIN TEMP SP *	Minimum room temperature setpoint	72 (22)	50-80 (10-27)
HI AIR TEMP	High room air temperature alarm	80 (27)	35 to 95 (2-35)
LO AIR TEMP	Low room air temperature alarm	55 (13)	35 to 95 (2-35)

\* For optimal cooling performance, the minimum temperature setpoint should be at least 1-2° below the expected temperature at the remote sensor, which may require additional consideration of the remote sensor location or minimum temperature setting. If the minimum temperature setpoint is set above the typical remote temperature sensor reading, this will reduce the Liebert XD cooling output and, in extreme cases, cause erratic Liebert XD performance.

To reach the SETPOINTS menu:

1. Press the MENU button.
2. Press ENTER when the SETPOINTS menu is displayed.
3. Use the up and down arrow keys to move through the menu and view the setpoints.

To change a setpoint, follow the steps above, then:

1. Press the ENTER key to change a setpoint. (The control will ask for a setpoint password if passwords are enabled. Use the up and down arrow keys and ENTER key to enter the three-digit password when prompted.)
2. Use the up and down arrow keys to change the setpoint.
3. Then, press ENTER to accept the new setpoint. When finished, press the ESC key two to three times to return to the main display.



### NOTE

*Setpoints and system setup parameters are kept in non-volatile memory.*

The user setpoints and ranges are:

### MIN TEMP SP

This setpoint is used to keep the room temperature above the setpoint. The Liebert XDC can lower the room temperature too much depending on the room dew point and load. This setpoint will back off the cooling to keep the room temperature above this temperature, see **5.3.1 - Viewing or Changing Settings**.



### NOTE

*This is not a true room temperature setpoint. The Liebert XDC will try to cool as much as possible. If it is able to cool the room to this setpoint, it will back off its cooling capability to try to keep the room temperature at or above this setpoint, but the Liebert XDC has no heaters, so it cannot warm the room.*

### HI AIR TEMP

This is the temperature at which the HIGH REMOTE TEMP and HIGH LOCAL TEMP alarms will be activated, see **5.3.1 - Viewing or Changing Settings**.

### LO AIR TEMP

This is the temperature at which the LOW REMOTE TEMP and LOW LOCAL TEMP alarms will be activated, see **5.3.1 - Viewing or Changing Settings**.

### 5.3.3 STATUS

The user can check the status of cooling percentage, pump and compressor operating status and temperature of the refrigerant.

VALVE OPEN %—0-100  
 COMP 1A, 2A, 1B, 2B—On/Off  
 PUMP 1—On/Off  
 PUMP 2—On/Off  
 REFRIG T—Refrigerant temperature 0-100°F

### 5.3.4 ACTIVE ALARMS

This submenu allows the user to review any present alarms. If no alarms are present, the screen will read **No Alarms Present**. If any alarms are occurring, the screen will display **Alarm XX of YY**, followed by the alarm text (**XX** is the reference number of the alarm shown, **YY** is the total number of alarms).

To view any active alarms:

1. Press the MENU key.
2. Scroll to the ACTIVE ALARMS menu by using the up and down arrow keys.
3. Press the ENTER key to access the menu.
4. Use the up and down arrow keys to move through the menu and view which alarms are active.

If there are no active alarms the display will read NO ALARMS. If any alarms are present, the display will list them. When finished, press the ESC key two to three times to go to the main display.

### 5.3.5 ALARM HISTORY

This submenu allows the user to review the 60 most-recent alarms. The first line of the screen will show the alarm number—01 being the newest—and the name of the alarm. The second line of the screen will show the most recent alarm's date and the time in 24 hour format.

To view the alarm history:

1. Press the MENU key.
2. Scroll to the ALARM HISTORY menu by using the up and down arrow keys.
3. Press the ENTER key to access the menu.
4. Use the up and down arrow keys to scroll through the menu and view the alarm history.
5. Press the ESC key two to three times to return to the main display.

### 5.3.6 TIME

The controller time clock must be set to allow for time stamping of the alarms for alarm history. To change the time press ENTER to select the function, then use the up or down arrow key to change the first character, press Enter to store, then press the up or down arrow key to change the second character, press Enter to store, etc.



#### NOTE

*The clock uses the 24 hour system (for example: 17:00 would be 5:00 PM). Battery backup protects the date and time settings.*

### 5.3.7 DATE

The controller date must be set to allow for time stamping of the alarms for alarm history. To change the date press ENTER, then use the up or down arrow key to change the first character, press ENTER to store, press the up or down arrow key to change the second character, etc.

### 5.3.8 SETUP OPERATION



#### NOTE

None of these setpoints should be changed before consulting a Liebert representative. Changing any of these setpoints could drastically affect the system.

Selecting Setpoint/Setup from the Main Menu will display the following selections:

**Table 22 Setup operation functions default values and allowable ranges.**

Menu Item	Function	Default	Range
RESTART	Restart time delay	0.1 min	0 to 9.9 min (0 = manual restart)
C/F DEGREES	Celsius or Fahrenheit	F	C or F
PUMP START TD	Pump start time delay	10 sec	3 - 120 sec
PUMP WAIT TD	Pump wait time delay	10 sec	3 - 120 sec
PUMP OFF TD	Pump off time delay	5 sec	5 - 120 sec
LEAD PUMP	Lead Pump	Pump 1	Pump 1/Pump 2
DIPSWCH	DIP switch status	NA	NA

To view the SETUP OPERATION menu

1. Press the MENU key.
2. Use the up and down arrow keys to move to the SETUP OPERATIONS menu.
3. Press the ENTER key to enter into the menu.
4. Use the up and down arrow keys to move through the menu and view the setpoints.
5. Press the ENTER key to change a setpoint. (The control will ask for a service password if passwords are enabled. Use the up and down arrow keys and ENTER key to enter the three-digit password when prompted.)
6. Use the up and down arrow keys to change the setpoint.
7. Press ENTER to accept the new setpoint.
8. When finished, press the ESC key two to three times to return to the main display.



#### NOTE

*Setpoints and system setup parameters are kept in non-volatile memory.*

#### RESTART

This is the time delay after which the control will attempt to restart the Liebert XDC after a loss of power. It is programmable from 0.1-9.9 minutes in 6-second (0.1 minute) increments. The user can also select **NO**. If **NO** is selected, the system **WILL NOT** automatically restart. The default is 0.1 minutes.

#### C/F DEGREES

The user may select control and alarm parameters in either Celsius or Fahrenheit. The default is degrees Fahrenheit.

#### PUMP START TD

The user may set a Pump Start Time Delay to ensure that refrigerant begins flowing when the pump starts. If refrigerant does not begin flowing before the user-set delay expires, the pump will be turned off (see **PUMP OFF TD**).

#### PUMP WAIT TD

The user may set the pump wait time delay to prevent the pump from continuing to run when refrigerant is not flowing. If a pump is running normally and refrigerant flow is lost, the pump will stay on for the specified amount of time trying to re-establish refrigerant flow. If refrigerant flow resumes during the specified interval, the pump will continue operating. If the wait time expires and refrigerant flow has not resumed, the pump will shut down (see **PUMP OFF TD**).

**PUMP OFF TD**

The user can set the amount of time a pump will remain off when refrigerant flow is interrupted or stops. After the time delay has expired, the control will try to restart the pump (see **PUMP START TD**).

**LEAD PUMP**

This allows the user to select which pump is the active pump. It can be set to PUMP 1 or PUMP 2. The control will operate the respective pump unless a loss of flow condition occurs. On a LOSS OF FLOW condition, the control will switch to the standby pump after the LOSS OF FLOW alarm time delay has elapsed and the LOSS OF FLOW alarm has been annunciated. The default is PUMP 1.

**LEAD TANDEM**

Not currently used.

**DIPSWCH**

This allows the user to read the eight-position DIP switch located on the control board. The switches are numbered according to the numbers on the DIP switch. The numeral **1** indicates the switch is ON and a **0** indicates the switch is OFF. These switches are factory-set and should not require any user changes.

**Table 23** Liebert XDC DIP switches and factory settings

DIP Switch	Factory Setting
1	Off
2	Off
3	Off
4	Off
5	Off
6	Off = Standard, On = Dual Source
7	Off
8	Off

**VALVE TIME**

Valve travel time is not currently used.

**VLV ST OPEN**

Valve start open % is not currently used.

**VLV START TD**

Valve start time delay is not currently used.

**MIN VLV SET**

Minimum valve setpoint is not currently used.

**COMP SEQ ON**

When the Liebert XDC is started, this is the time delay before the next compressor comes on when the control is sequencing on compressors.

**COMP OFF TD**

This is how long a compressor must be off before the control will turn it back on.

**INNERSTAGE TD**

This is how long the control must wait between compressor stage changes during normal operation.

**WSK1 TD**

Compressor winter start kit time delay for all compressors.

**WSK2 TD**

The winter start kit 2 time delay is not currently used.

**100% START TD**

This is how long the control will keep the unit at 100% cooling during startup after all compressors have staged on.

### 5.3.9 SETPT PASSWORD

To prevent unauthorized changes to the control setpoints and alarm settings, the Liebert XDC may be configured to require a three-digit password before permitting setpoint or alarm setting changes.

To enable this feature, set DIP switch #8 in the wall box to the Off position. If DIP switch #8 is On, no password is required. Factory default for the setpoint password is **123**.

To change the password:

1. Press the MENU key to display the Main Menu.
2. Use the up or down arrow keys to scroll to the SETPT PASSWORD function.
3. Press ENTER to access the SETPT PASSWORD function. The LCD will display three zeros—000.
4. Enter the present, three-digit password
  - a. Use the up or down arrow key to enter the first number.
  - b. Press the ENTER button to select the second number in the password.
  - c. Use the up or down arrow key to enter the second number.
  - d. Enter the third number by repeating Steps b and c.
  - e. Press the ENTER button to accept the password. The LCD will display the message PASSWORD OK.
5. Press the ENTER button; the LCD displays the message ENTER NEW PSW and the current password. The first numeral will be selected.
6. Use the up or down arrow key to enter the first number of the new password. Press the Enter button to select the second numeral in the password.
7. Use the up or down arrow key to enter the second number of the new password. Press the Enter button to select the third numeral in the password.
8. Use the up or down arrow key to enter the third number of the new password. Press the Enter button to save the new password.

### 5.3.10 SETUP PASSWORD

To prevent unauthorized changes to the setup configurations, the Liebert XDC may be configured to require a three-digit password before permitting setup configuration changes.

To enable this feature, set DIP switch #8 in the wall box, to the Off position. If DIP switch #8 is On, no password is required. Factory default for the setup password is **321**.

To change the password:

1. Press the MENU key to display the Main Menu.
2. Use the up or down arrow keys to scroll to the SETUP PASSWORD function.
3. Press ENTER to access the SETUP PASSWORD function. The LCD will display three zeros—000.  
Enter the present, three-digit password
  - a. Use the up or down arrow key to enter the first number.
  - b. Press the ENTER button to select the second number in the password.
  - c. Use the up or down arrow key to enter the second number.
  - d. Enter the third number by repeating **Steps b and c**.
  - e. Press the ENTER button to accept the password. The LCD will display the message PASSWORD OK.
4. Press the ENTER button; the LCD displays the message ENTER NEW PSW and the current password. The first numeral will be selected.
5. Use the up or down arrow key to enter the first number of the new password. Press the Enter button to select the second numeral in the password.
6. Use the up or down arrow key to enter the second number of the new password. Press the Enter button to select the third numeral in the password.
7. Use the up or down arrow key to enter the third number of the new password. Press the Enter button to save the new password.



### 5.3.11 CALIBRATE SENSORS

The temperature and humidity sensor can be calibrated by selecting this menu item. The temperature sensor can be calibrated  $\pm 5^{\circ}\text{F}$  and the humidity sensor can be calibrated  $\pm 10\%$  RH. To prevent coil condensation that could damage the Liebert XDC, the sensors must be calibrated to a known source.

### 5.3.12 ALARM ENABLE

At the user's discretion, some alarms may be enabled or disabled. If an alarm is disabled, the alarm condition will not be monitored and will not trip, will not be in ACTIVE ALARMS, will not be in ALARM HISTORY and will not be annunciated.

These alarms may be enabled or disabled:

- FLOW LOSS P1—loss of refrigerant flow with Pump 1 alarm
- FLOW LOSS P2—loss of refrigerant flow with Pump 2 alarm
- CUSTOMER—customer alarm
- HI RMT TEMP—high remote temperature alarm
- LO RMT TEMP—low remote temperature alarm
- HI LCL TEMP—high local temperature alarm
- LO LCL TEMP—low local temperature alarm

To determine whether an alarm is enabled or disabled:

1. Press the MENU key.
2. Use the up and down arrow keys to move to the ALARM ENABLE menu.
3. Press the ENTER key to access the menu. Use the up and down arrow keys to move through the menu and view which alarms are enabled or disabled. (YES means that the alarm is enabled, NO means that the alarm is disabled.)

To change an alarm from enabled to disabled, or vice versa

1. Determine whether the alarm is enabled or disabled (see above).
2. Use the up and down arrow keys to scroll to the alarm to be changed.
3. Press the ENTER key. (The control will ask for a service password if passwords are enabled. Use the up and down arrow keys and ENTER key to enter the three-digit password.)
4. Press the ENTER key again to change the alarm.
5. Press the ESC key two to three times to return to the main display.

### 5.3.13 ALARM TIME DELAY

Some alarms can be programmed with a time delay as a means of preventing nuisance alarms. This function specifies the amount of time an alarm must be present before the Liebert XDC recognizes and annunciates the alarm. If the alarm condition goes away before the time delay has expired, the alarm will not be recognized, and the time delay timer will be reset. This can be used as a filter to prevent nuisance alarms from transient events.

Time delays for these alarms may be changed:

- CUSTOMER—customer alarm
- HI RMT TEMP—high remote temperature alarm
- LO RMT TEMP—low remote temperature alarm
- HI LCL TEMP—high local temperature alarm
- LO LCL TEMP—low local temperature alarm
- LO REFRIG T—low refrigerant temperature alarm

To view the time delay for an alarm:

1. Press the MENU key.
2. Use the up and down arrow keys to move to the ALARM TIME DELAY menu. Press the ENTER key to enter into the menu. Use the up and down arrow keys to move through the menu and view the alarm time delays.

To change the time delay for an alarm:

1. Press the ENTER key. (The control will ask for a service password if passwords are enabled. Use the up and down arrow keys and ENTER key to enter the three-digit password when prompted.)
2. Press the ENTER key again on the alarm to select the alarm to be changed.
3. Use the up and down arrow keys to change the alarm time delay.
4. Press the ENTER key to record the change.
5. Press the ESC key two to three times to return to the main display.

### 5.3.14 COM ALARM ENABLE

Each individual alarm can be selected to energize or not to energize the common alarm relay. If the energize common alarm function is set to YES, the relay is energized immediately as the alarm is annunciated and de-energized when the alarm condition goes away (only after the alarm has been recognized). If the alarm is completely DISABLED, the alarm has no effect on the common alarm relay.

Use the up or down arrow key to scroll to a particular alarm, press the ENTER button to select it, then press the ENTER button to change the state (Yes or No).

### 5.3.15 CUSTOM ALARMS

This is the menu where the user selects the alarm message that will be displayed when there is an input to the customer alarm input on the control board. This menu has four choices: one user-defined custom message (see **CUSTOM TEXT** below for details) and three preprogrammed messages:

- SMOKE DETECTED
- CUSTOM 1 (default custom message. If the user enters a custom text message, that custom text will replace CUSTOM 1.)
- STANDBY UNIT ON

1. Press the ENTER button to access the menu
2. Use the up or down arrow key to view the messages.
3. Press the ENTER button to select the message to be displayed.

### 5.3.16 CUSTOM TEXT

This menu permits the user to set up a custom text message with a maximum length of 16 characters. The message may use any of the following characters or a blank space:

**ABCDEFGHIJKLMNOPQRSTUVWXYZ#%\*-0123456789.**

This custom text can be designated as the custom alarm text in the CUSTOM ALARMS menu (see **CUSTOM ALARMS** above). To define the message:

1. Press the ENTER button to access the menu.
2. Use the up or down arrow key to change the character with the pointer below it.
3. Press the ENTER button to go to the next character.
4. Repeat the steps for all characters in the message (maximum of 16 characters).
5. Press the ENTER button to accept new custom text.

### 5.3.17 DIAGNOSTICS

This allows the user to perform checks on inputs, outputs, and conduct a test of the Liebert XDC control board from the wall box.

Entering the TEST OUTPUTS will interrupt system operation. Selecting TEST INPUTS or TEST MICRO will not interrupt system operation. Pressing ENTER and selecting TEST OUTPUTS will permit the user to toggle the following outputs on and off:

PUMP 1—On/Off  
 PUMP 2—On/Off  
 COMP 1A, 2A, 1B, 2B—On/Off  
 GREEN LAMP—On/Off  
 RED LAMP—On/Off  
 COMMON ALARM—On/Off  
 LLSV1, LLSV2—On/Off  
 HGSV1, HGSV2—On/Off  
 HGV1, HGV2—On/Off  
 DEHYDRATION1, DEHYDRATION2—On/Off

Pressing ENTER and selecting TEST INPUTS will permit the user to read the following inputs:

INPUT POWER—On/Off  
 CONDENSATION—On/Off (condensation detection)  
 DIFF PRESSURE—On/Off (differential pressure switch)  
 CUSTOMER ALARM—On/Off

Pressing ENTER and selecting TEST MICRO will permit the user to test the microcontroller and associated circuitry on the Liebert XDC control board.

## 6.0 ALARM DESCRIPTIONS AND SOLUTIONS

### 6.1 Alarm Descriptions



#### NOTE

*Alarms **must be acknowledged** before they can be reset. To acknowledge or silence an alarm, press the ALARM SILENCE / ? key.*

- **LOSS OF FLOW P1** – Activated when pump 1 is commanded to run and the differential pressure switch does not sense differential pressure (set at 6 psi; 41 kPa; 0.41 bars). After attempting to start pump 1 for a period of 120 seconds (including time delays), the Liebert XDC will automatically switch to the other pump to establish flow.
- **LOSS OF FLOW P2** – Activated when pump 2 is commanded to run and the differential pressure switch does not sense differential pressure (set at 6 psi; 41 kPa; 0.41 bars). After attempting to start pump 2 for a period of 120 seconds (including time delays), the Liebert XDC will automatically switch to the other pump to establish flow.
- **PUMP SHORT CYCLE** – Activated when the Liebert XDC is trying to establish flow (differential pressure) and it is unable to do it. The Liebert XDC will attempt to establish flow (differential pressure) for 4 minutes on each pump, for a total of 8 minutes. If this cycling occurs within 30 minutes (can be adjusted from 10 to 60 minutes) and the Liebert XDC still does not establish flow, a **SHORT CYCLE** alarm will be present. This alarm will shut down the Liebert XDC, main power (disconnect switch) must be turned OFF then back ON to clear this alarm.
- **CUSTOMER ALARM** – Activated when 24VAC signal is applied to the customer alarm input on the control board. Alarm will reset when the 24VAC signal is taken away.
- **CONDENSATION** – Activated when water is detected at the Liebert XD cooling module (24VAC is applied to the condensation input on the control). When this alarm is active, the control will raise its refrigerant control point by 4 degrees Fahrenheit. Alarm will reset when the 24VAC signal is taken away or main power removed.
- **FAN FAILURE ALARM** – Not currently being used.
- **HIGH REMOTE TEMP & HIGH LOCAL TEMP** – Activated when the remote or local temperature exceeds the user specified setpoint. See **5.3.2 - SETPOINTS**. Alarm will reset itself when the room temperature drops below the setpoint.
- **LOW REMOTE TEMP & LOW LOCAL TEMP** – Activated when the remote or local temperature is below the user specified setpoint. See **5.3.2 - SETPOINTS**. Alarm will reset itself when the room temperature raises above the setpoint.
- **REMOTE SENS PROB** – Activated when no signal is present from the remote temperature or humidity sensors. Alarm will reset when the temperature and humidity signals are re-established.
- **LOCAL SENS PROB** – Activated when no signal is present from the local temperature or humidity sensors or communications is lost from the display. Alarm will reset when the temperature and humidity signals are re-established.
- **HIGH DEWPOINT** – Activated when the room dew point exceeds the user specified setpoint. See **5.3.2 - SETPOINTS**. Alarm will reset itself when the room temperature drops below the setpoint.
- **HIGH HEAD PRESSURE C1A** – Activated when a high head pressure signal is sensed from compressor 1A by the control.
- **HIGH HEAD PRESSURE C1B** – Activated when a high head pressure signal is sensed from compressor 1B by the control.
- **HIGH HEAD PRESSURE C2A** – Activated when a high head pressure signal is sensed from compressor 2A by the control.
- **HIGH HEAD PRESSURE C2B** – Activated when a high head pressure signal is sensed from compressor 2B by the control.
- **LOW PRESSURE CKT 1** – Activated when the low-pressure switch for compressor circuit #1 doesn't send the proper signal during normal operation, or during pump-down.
- **LOW PRESSURE CKT 2** – Activated when the low-pressure switch for compressor circuit #2 doesn't send the proper signal during normal operation, or during pump-down.

- **SHORT CYCLE C1A** – Activated when compressor 1A turns On, Off, then back On, 5 times within 10 minutes, or 10 times within 1 hour.
- **SHORT CYCLE C1B** – Activated when compressor 1B turns On, Off, then back On, 5 times within 10 minutes, or 10 times within 1 hour.
- **SHORT CYCLE C2A** – Activated when compressor 2A turns On, Off, then back On, 5 times within 10 minutes, or 10 times within 1 hour.
- **SHORT CYCLE C2B** – Activated when compressor 2B turns On, Off, then back On, 5 times within 10 minutes, or 10 times within 1 hour.
- **HIGH REFRIGERANT TEMP 1** – Activated when the refrigerant temperature sensed from refrigerant temperature sensor 1, exceeds the user specified setpoint. See **5.3.2 - SETPOINTS**. Alarm will reset itself when the refrigerant temperature drops below the setpoint.
- **LOW REFRIGERANT TEMP 1** – Activated when the refrigerant temperature sensed from refrigerant temperature sensor 1, drops 1.5 degrees Fahrenheit below the refrigerant temperature control point. Alarm will reset itself if the refrigerant temperature raises back up before the control shuts down because of low refrigerant temperature.
- **FAILED REFRIGERANT SENSOR 1** – Activated when the control stops receiving a signal from the refrigerant temperature sensor 1. If this alarm becomes active, the control will slowly back down cooling over a 9-minute period. This alarm will shut down the Liebert XDC, main power (disconnect switch) must be turned OFF then back ON to clear this alarm.
- **HIGH CHILLED WATER TEMP** – not currently used.
- **LOW CHILLED WATER TEMP** – not currently used.
- **FAILED CHILLED WATER SENSOR** – not currently used.
- **VALVE FAILURE** – not currently used.
- **LOSS OF POWER** – Activated when the unit is ON and operational, and 24VAC power to the control is lost to the control. This alarm will be emitted when power is restored to the control (unit). Unit will restart at a user defined time delay after power is restored. See **5.3.8 - SETUP OPERATION**. Alarm will reset itself after 30 seconds of run time.



#### NOTE

*Alarms MUST BE ACKNOWLEDGED before they can be RESET. To acknowledge / silence alarms press the Alarm Silence / ? key.*

## 6.2 Red and Green Lamp Indicators

Liebert's XDC has two lamps that indicate the unit's operating condition, one green, one red.

The green lamp lights only when the Liebert XDC is ON and running with no alarms.

The red lamp lights in two instances:

1. If the unit is on and running with an active alarm

*OR*

2. If the unit is shut down because of an alarm.

The red lamp will flash when an alarm is being annunciated. The red lamp will stop flashing and the beeper in the display will stop beeping when the ALARM SILENCE / ? key is pressed.

### 6.3 Enable / Disable Alarms

Any alarm may be enabled or disabled. If an alarm is disabled, the alarm condition will not be monitored and will not trip, will not be in ACTIVE ALARMS, will not be in ALARM HISTORY and will not be annunciated. To enable or disable an alarm, or to check whether an alarm is enabled or disabled:

1. Press the MENU key.
2. Use the up or down arrow key to move to the ALARM ENABLE menu.
3. Press the ENTER key to access the menu.
4. Use the up or down arrow key to move through the menu and view which alarms are enabled or disabled. YES means that the alarm is enabled, NO means that the alarm is disabled.

To change it:

1. Press the ENTER key. The control will ask you for a service password whether passwords are enabled.
2. Use the up and down arrow keys and ENTER key to key in the three-digit password.
3. Press the ENTER key again on the alarm to change it.
4. When finished, press the ESC key two to three times to get back to the main display.

### 6.4 Alarm Time Delays

All of the alarms can have their delay times changed. An alarm time delay is the period that the control has to see a specific condition exist before it will alarm that condition. This can be used as a filter to prevent nuisance alarms.

To change an alarm time delay, or to view a current alarm time delay:

1. Press the MENU key.
2. Use the up or down arrow key to move to the ALARM TIME DELAY menu.
3. Press the ENTER key to access the menu. Use the up or down arrow key to move through the menu and view the alarm time delays.

To change an alarm time delay:

1. Press the ENTER key. The control will ask for a service password if passwords are enabled.
2. Use the up and down arrow keys and ENTER key to key in the three-digit password.
3. Press the ENTER key again on the alarm to change it.
4. Use the up and down arrow keys to change the alarm time delay.
5. Press the ENTER key to accept the change.
6. When finished, press the ESC key two to three times to get back to the main display.

### 6.5 View Active Alarms

To view the active alarms:

1. Press the MENU key.
2. Use the up or down arrow key to move to the ACTIVE ALARMS menu.
3. Press the ENTER key to enter into the menu.
4. Use the up or down arrow key to move through the menu and view which alarms are active.  
If there are no active alarms the display will read NO ALARMS. If alarms are present, the display will list them accordingly.
5. When finished, press the ESC key two to three times to get back to the main display.

## 6.6 View Alarm History

To view the alarm history:

1. Press the MENU key.
2. Use the up or down arrow key to move to the ALARM HISTORY menu.
3. Press the ENTER key to enter into the menu.
4. Use the up or down arrow key to move through the menu and view the alarm history.  
This menu will show the most recent alarm first. This menu also will display the alarm name, alarm number and the time and date of occurrence for the last 60 alarms.
5. When finished, press the ESC key two to three times to get back to the main display.

## 6.7 System Shutdown Causes

- **Unit Is Off By Refrig Sens Fail:** The control has lost its signal from the refrigerant temperature sensor. The control has no way of controlling the refrigerant temperature, so the unit is shut off. Main power (disconnect switch) must be turned OFF then back ON to clear this alarm.
- **Unit Is Off By Pump Short Cycle:** The control was unable to get a pump started at startup or after a loss of differential pressure. The control looks at the SHORT CYCLE time delay. If it cannot establish differential pressure within that amount of time the unit is shut off. The user may set this time by changing the SHORT CYCLE alarm time delay. Main power (disconnect switch) must be turned OFF then back ON to clear this alarm.
- **Unit Is Off By Low Refrig Temp:** The control was unable to raise the refrigerant temperature to the calculated refrigerant temperature control point. The unit is shut off, because if the control cannot raise the refrigerant temperature to the calculated refrigerant temperature control point, there will be a possibility of water condensing on the refrigerant piping and receiving coils. Main power (disconnect switch) must be turned OFF then back ON to clear this alarm.

## 7.0 TROUBLESHOOTING

**Table 24 Liebert XDC troubleshooting**

Symptom	Possible Cause	Check or Remedy
Pump/compressor will not energize	No main power	Check L1, L2, and L3 for rated voltage.
	Loose electrical connections	Tighten connections.
	Overloads tripped	Allow pump to cool. Check amp draw.
	Tripped circuit breaker	Check circuit breaker to pump(s).
	Incorrect phase wiring	See <b>Table 18</b> .
Pump will not run	Isolation valve(s) on pump suction and/or discharge is closed.	Open all isolation valves completely during normal operation.
	Liebert XD cooling modules are Off.	Check Liebert XD cooling modules to make sure that they are ON prior to starting the Liebert XDC
	Low Refrigerant Temperature (high dew point)	Check alarm(s) history on Liebert XDC. The Liebert XDC was operating below the dew point for a significant amount of time. Check humidity in conditioned space; lower humidity if necessary to allow Liebert XDC to operate at a lower temperature. (Disconnect must be switched to Off then back to On to allow Liebert XDC to reset.)
	Incorrect location of temperature-humidity sensors	Place the sensor on the return air side of the primary air mover (i.e., Liebert Deluxe System 3). Do not install the sensor near unsealed doors, windows and similar areas.
	Pressure switch not making contact	Check both differential pressure settings. If not within 6 psi, $\pm 1$ psi (41 kPa, $\pm 7$ kPa; 0.41 bars, $\pm 0.07$ bars) then manually change accordingly.
	Not enough charge	See <b>2.7 - Filling the Direct Expansion (DX) Circuit—R-407c</b> .
Pump noisy	Cavitation due to vapor in pump	Check for adequate charge in system, refer to the user manual. <b>2.7 - Filling the Direct Expansion (DX) Circuit—R-407c</b>
	Pump is rotating in reverse	See <b>Table 18</b>
	Worn motor bearings	Replace pump
Liebert XDC (Pump) suddenly stops	Low Refrigerant Temperature (high dew point)	Check humidity of room along with location of remote sensors. Make sure that the sensors are not located in a cold area where there is a lack of sufficient air flow.
	Loss of power	When power is restored, the Liebert XDC will automatically restart.
	Clogged filter/dryer and/or impeller	Clean out debris.
	Leak in system - loss of charge	Check the entire system for leaks with a refrigerant sniffer. Repair as necessary.
Room becomes too cold	Lack of load in the room	If there is no cooling required, turn the Liebert XDC off at the I/O button.
	Minimum room temperature setpoint is too low.	Check the setpoint by following instructions in <b>5.3.2 - SETPOINTS</b> .
	Incorrect location of temperature-humidity sensors.	Place the sensor on the return air side of the primary air mover (i.e., Liebert Deluxe System 3). Do not install the sensor near unsealed doors, windows, and similar areas.

Table continued on following page



**Table 24 Liebert XDC troubleshooting (continued)**

Symptom	Possible Cause	Check or Remedy
Room becomes too warm	Liebert XDC is off.	Check status of the Liebert XDC at the user interface. Turn system On at I/O button if system is Off.
	High dew point	Check temperature and relative humidity (RH) of room. Lower RH setpoint if necessary to lower dew point. At normal room temperature of 68°F (20°C), the RH should be set to 50% or lower.
	Liebert XD cooling modules are Off.	Check Liebert XD cooling modules to make sure that they are On before starting the Liebert XDC.
	Minimum room temperature setpoint is too high.	Check the setpoint by following instructions in <b>5.3.2 - SETPOINTS</b> .
	Incorrect location of temperature-humidity sensors	Place the sensor on the return air side of the primary air mover (i.e., Liebert Deluxe System 3). Do not install the sensor near unsealed doors, windows, and similar areas.
Pipe rattle	Loose pipe connections	Check pipe connections.
Actuator motors (if applicable)	No 24VAC power to motor	Check for 24VAC between P2-1 and P2-4.
	No signal from control	Check 24VAC at P22-1 (close) or P22-3 (close).
	Motor not operating	Unplug P22 completely off of the board. Jumper P22-5 to P2-4 for grounding, then jumper P22-1 to P2-1 to drive close. Remove jumper to close, and then jumper P22-3 to P2-1 to drive open. If motor fails to work, replace it.
Motor burnout	Check control panel for welded contactor contacts or welded overload contacts	Replace defective components.
Main 24VAC fuse trips	Shorts or loose connections	Check the wiring connections of the 24VAC circuit.
	Faulty circuit board	Replace the circuit board.
Unstable pump operation	R-134a pump loop is overcharged	While pump is running R-134a receiver level must be within recommended levels (see <b>Figure 31</b> ).

## 8.0 MAINTENANCE

The Liebert XD system components require little maintenance when proper fluid levels are maintained and proper startup and operation procedures are followed. The following tasks should be performed at the intervals stated:

1. Check sight glass level of receiver on all circuits every 4-6 weeks. During normal operation, the level should be at or above the first sight glass.
2. Check system for leaks every 4-6 weeks

### 8.1 Fluorinated Greenhouse Gas Requirements

Stationary air conditioning, refrigeration, heat pump equipments and stationary fire protection systems in the European Community market and operating with fluorinated greenhouse gases (f-gas), such as R407C, R134a, R410A, must comply with the F-Gas Regulation: (EC) No. 842/2006 (F-gas). The regulation prohibits, among other actions, venting fluorinated greenhouse gases to the atmosphere.

The F-Gas Regulation requires operators to use all measures that are technically feasible and do not entail disproportionate cost to prevent leakage of these gases, to test for leakage regularly and to recover f-gas during equipment service and maintenance and before disposing of equipment.

Refer to the full regulation for additional details.

### 8.2 Air Cooled Condenser

Restricted airflow through the condenser coil will reduce the operating efficiency of the unit and can result in high compressor head pressure and loss of cooling.

Clean the condenser coil of all debris that will inhibit air flow. This can be done with compressed air or commercial coil cleaner. Check for bent or damaged coil fins and repair as necessary. In winter, do not permit snow to accumulate around the sides or underneath the condenser.

Check all refrigerant lines and capillaries for vibration isolation. Support as necessary. Visually inspect all refrigerant lines for signs of oil leaks.

Figure 33 Outdoor fan/condenser configuration

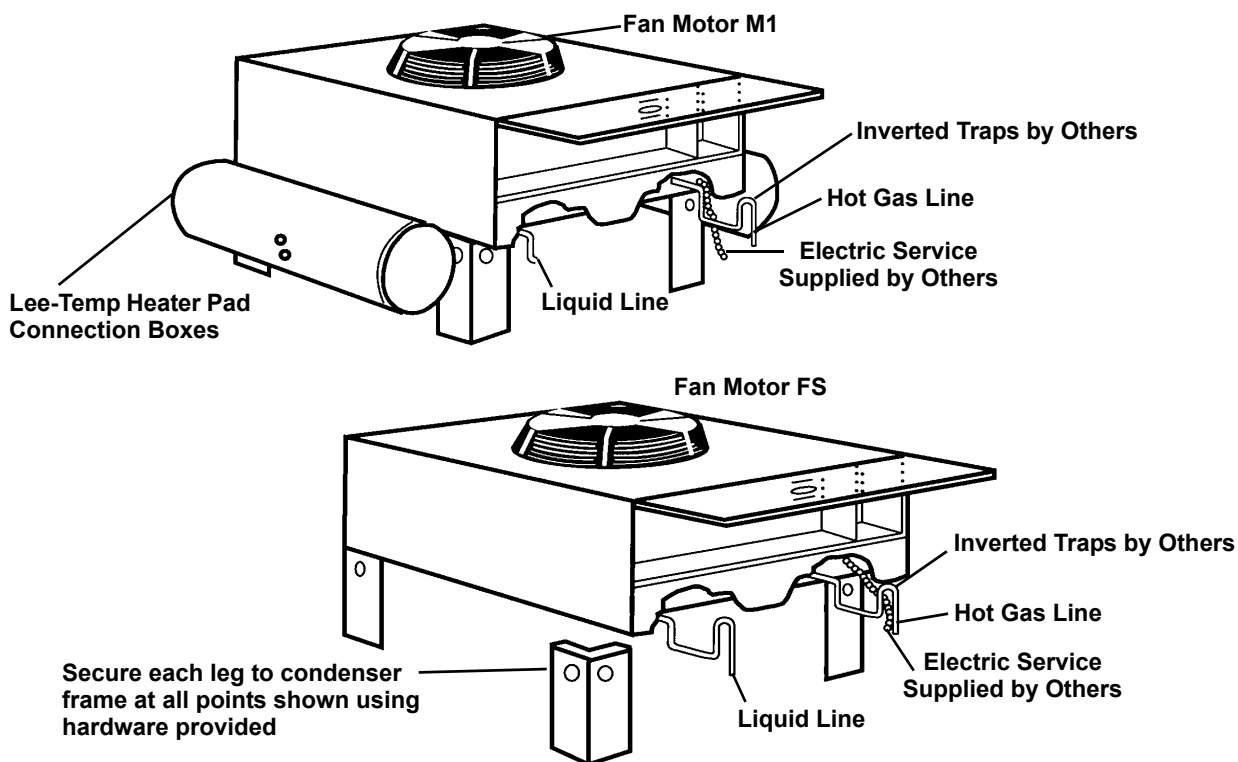

## 8.3 Water/Glycol Floor Stand Condenser

### 8.3.1 Shell and Tube Condensers

Each water or glycol cooled module has a shell and tube condenser which consists of a shell, removable heads, gaskets and cleanable copper tubes.

It may be necessary to clean the copper tubing periodically to remove any scale or lime that should collect (periods between cleanings will vary with local water conditions). As deposits build up, a cleaning tool, available at any refrigeration supply house, should be used to clean the heat exchanger tubes.

1. Stop the unit (using the start/stop switch) and allow the compressor to pump down.
2. Open the disconnect switch.
3. Shut off the water supply valve to the condenser.
4. Drain the water from condensers and piping.
5. Remove the bolts securing each head and slowly pry them free.
6. Remove old gaskets and inspect sealing surfaces for pits and corrosion.
7. Swab the condenser tubes with a tube-cleaning tool.
8. When the tubes are clean, reinstall the heads using new factory gaskets.
9. Consult factory for specific torque requirements.
10. Reconnect the piping, open the water supply valve, vent the system and check for leaks.

### 8.3.2 Regulating Valves

The water regulating valves automatically regulate the amount of fluid necessary to remove the heat from the refrigeration system, permitting more water to flow when load conditions are high and less fluid to flow when load conditions are low. The valve consists of a brass body, balance spring, valve seat, valve disc holders, capillary tube to discharge pressure and an adjusting screw.

#### Testing the Water Regulating Valve Function

1. Turn the refrigeration system Off.
2. Wait 10 to 15 minutes—water should stop flowing.

If the water continues to flow, the valve is either improperly adjusted (with head pressure too low) or the pressure sensing capillary is not connected properly to the condenser. Consult **Table 24 - Liebert XDC troubleshooting**.

### 8.3.3 Glycol Solution Maintenance

Proper rust inhibitor maintenance is necessary to prevent corrosion of the glycol system. Consult the glycol manufacturer for testing and maintenance of inhibitors. Do not mix products from different manufacturers.

Inhibitor maintenance requirements depend on local water conditions. Analyzing water samples before installation and every six months will assist in developing a schedule. Inspect the solution and filter residue to determine whether corrosion is occurring.

A water treatment specialist may be required to set up a treatment program to remedy some water-caused problems.

## 9.0 SPECIFICATIONS

**Table 25 Liebert XDC specifications**

Models	XDC160 Air		XDC160 Water / Glycol
	XDC160AA	XDC160AM	189192G3 189192G5
Cooling Capacity, tons (kW)	46 (160)	37 (130)	See Tables 26, 27 and 28 for Water/Glycol performance data
Minimum Load	The Liebert XDC's minimum recommended operating load is 40% of system nominal capacity. For example, a Liebert XDC160 60Hz system's minimum load would be 64 kW. Loading below this value can unfavorably affect system operation. Consult factory for any loading below this recommendation.		
<b>Electrical Requirements</b>			
Input	460V-3ph-60Hz	380/415V-3ph-50Hz	460V-3ph-60Hz
Full Load Amps	79A		
Minimum supply wire sizing ampacity	84A		
Maximum fuse or circuit breaker size	100A		
<b>Dimensions, inches (mm)</b>			
Height - Main unit only	78 (1981)		
Height - Main unit only, as shipped	83 (2108)		
Width - Main unit	74 (1879)		
Depth - Main unit	34-5/8 (879)		
Height - Water / Glycol cooled condenser stand	N/A	24 (607)	
Width - Water / Glycol cooled condenser stand	N/A	72 (1829)	
Depth - Water / Glycol cooled condenser stand	N/A	33 (839)	
<b>Weight, lb (kg)</b>			
Main unit only	1800 (817)		
Main unit only, as shipped	Domestic: 1945 (882); Export: 2093 (949)		
Water / Glycol cooled condenser stand	N/A	1075 (488)	
Water / Glycol cooled condenser stand, as shipped	N/A	1150 (521)	
<b>Pipe Connections, inches, O.D., Cu</b>			
Liebert XD Coolant supply to XD cooling modules	1-1/8		
Liebert XD Coolant return from XD cooling modules	2-1/8		
Liquid line, DX circuit	7/8		
Hot gas line, DX circuit	1-3/8		
<b>Heat Rejection Equipment</b>			
95°F ambient air cooled condenser	1-CDL830 or 2-CSL415		N/A
<b>Number of XD Cooling Units Connected, Maximum (Minimum)</b>			
Liebert XDCF10	16 (6)		
Liebert XDH20	8 (4)		
Liebert XDH32	5 (2)		
Liebert XDO16	10 (4)		
Liebert XDO20	8 (4)		
Liebert XDV8	20 (8)		
Liebert XDV10	16 (7)		
Cabinet Exterior Finish	Black, matte finish, heat-fused powder coat		
Maximum Ambient Operating Temperature °F(°C)	86 (30)		
<b>Agency</b>			
Approvals	CSA	CE	CSA

**Table 26 Floor stand specifications—water-cooled Liebert XDC**

Models - 60 Hz	XDC160 Water Floor Stand - 60Hz				
Entering Fluid Temp °F (C)	65 (18)	70 (21)	75 (24)	85 (29)	95 (35)
<b>Performance Data</b>					
Cooling capacity, tons (kW)	46.1(162.3)	46.1(162.3)	46.1(162.3)	46.1(162.3)	44.5 (156.5)
Flow, GPM	50	58	70	110	142
Pressure Drop, psi (Ft Water)	2.7 (6.2)	4.9 (11.3)	5.4 (12.5)	20.7 (47.8)	27.3 (63.1)
<b>Heat Rejection Equipment</b>					
Water regulating valve size	1"	1"	1"	1"	1"
<b>Piping Connections</b>					
Water / glycol supply and return lines	2-1/8"	2-1/8"	2-1/8"	2-1/8"	2-1/8"

**Table 27 Floor stand specifications—Liebert XDC with 40% propylene glycol**

Models - 60 Hz	XDC160 Glycol Floor Stand - 60Hz - 40% PG		
Outside Ambient °F (°C)	95 (35)	100 (38)	105 (41)
Entering Fluid Temp °F (°C)	110 (43)	110 (43)	110 (43)
<b>Performance Data</b>			
Cooling capacity, tons (kW)	42.5 (149.4)		
Total Heat Rejection, (kW)	192.6		
Flow, GPM	206		
Pressure Drop, psi (ft water)	37.2 (85.9)		
<b>Heat Rejection Equipment</b>			
Drycooler	DNT 940A		2 x DNT 880A*
Drycooler Pressure Drop, psi (ft water)	6.7 (15.5)		2.9 (6.6)
Glycol pump package - 10hp	9A31258G3		
Pump Control Package - 208V	9A34606G47		
Pump Control Package - 460V	9A32114G4		
Pump Total Head @ 204 GPM, ft water	145		
Water regulating valve size	1-1/4"		
<b>Piping Connections</b>			
Water / glycol supply and return lines	2-5/8"		

\* When multiple drycoolers are used ensure flow is balanced.

**Table 28 Floor stand specifications—Liebert XDC with 40% ethylene glycol**

<b>Models - 60 Hz</b>	<b>XDC160 Glycol Floor Stand - 60Hz - 40% EG</b>		
Outside Ambient °F (°C)	95 (35)	100 (38)	105 (41)
Entering Fluid Temp °F (°C)	110 (43)	110 (43)	110 (43)
<b>Performance Data</b>			
Cooling capacity, tons (kW)	42.5 (149.4)		
Total Heat Rejection, (kW)	192.6		
Flow, GPM	204		
Pressure Drop, psi (ft water)	35.9 (82.9)		
<b>Heat Rejection Equipment</b>			
Drycooler	DNT 940A	2 x DNT 880A*	
Drycooler Pressure Drop, psi (ft water)	6.5 (15.1)	2.7 (6.3)	
Glycol pump package - 10HP	9A31258G3		
Pump Control Package - 208V	9A34606G47		
Pump Control Package - 460V	9A32114G4		
Pump Total Head @ 204 GPM, ft water	145		
Water regulating valve size	1-1/4"		
<b>Piping Connections</b>			
Water / glycol supply and return lines	2-5/8"		

\* When multiple drycoolers are used ensure flow is balanced.



# Ensuring The High Availability Of Mission-Critical Data And Applications.

Emerson Network Power, the global leader in enabling business-critical continuity, ensures network resiliency and adaptability through a family of technologies—including Liebert power and cooling technologies—that protect and support business-critical systems. Liebert solutions employ an adaptive architecture that responds to changes in criticality, density and capacity. Enterprises benefit from greater IT system availability, operational flexibility and reduced capital equipment and operating costs.

## Technical Support / Service Web Site

[www.liebert.com](http://www.liebert.com)

### Monitoring

800-222-5877

[monitoring@emersonnetworkpower.com](mailto:monitoring@emersonnetworkpower.com)

Outside the US: 614-841-6755

### Single-Phase UPS

800-222-5877

[upstech@emersonnetworkpower.com](mailto:upstech@emersonnetworkpower.com)

Outside the US: 614-841-6755

### Three-Phase UPS

800-543-2378

[powertech@emersonnetworkpower.com](mailto:powertech@emersonnetworkpower.com)

### Environmental Systems

800-543-2778

Outside the United States

614-888-0246

### Locations

#### United States

1050 Dearborn Drive

P.O. Box 29186

Columbus, OH 43229

#### Europe

Via Leonardo Da Vinci 8

Zona Industriale Tognana

35028 Piove Di Sacco (PD) Italy

+39 049 9719 111

Fax: +39 049 5841 257

#### Asia

7/F, Dah Sing Financial Centre

108 Gloucester Road, Wanchai

Hong Kong

852 2572220

Fax: 852 28029250

While every precaution has been taken to ensure the accuracy and completeness of this literature, Liebert Corporation assumes no responsibility and disclaims all liability for damages resulting from use of this information or for any errors or omissions.

© 2008 Liebert Corporation

All rights reserved throughout the world. Specifications subject to change without notice.

® Liebert is a registered trademark of Liebert Corporation.

All names referred to are trademarks

or registered trademarks of their respective owners.

SL-16671\_REV10\_04-08

## Emerson Network Power.

The global leader in enabling *Business-Critical Continuity*.

■ AC Power

■ Embedded Computing

■ Outside Plant

■ Racks & Integrated Cabinets

■ Connectivity

■ Embedded Power

■ Power Switching & Controls

■ Services

■ DC Power

■ Monitoring

■ Precision Cooling

■ Surge Protection

*Business-Critical Continuity*, Emerson Network Power and the Emerson Network Power logo are trademarks and service marks of Emerson Electric Co.

©2008 Emerson Electric Co.



## Free Manuals Download Website

<http://myh66.com>

<http://usermanuals.us>

<http://www.somanuals.com>

<http://www.4manuals.cc>

<http://www.manual-lib.com>

<http://www.404manual.com>

<http://www.luxmanual.com>

<http://aubethermostatmanual.com>

Golf course search by state

<http://golfingnear.com>

Email search by domain

<http://emailbydomain.com>

Auto manuals search

<http://auto.somanuals.com>

TV manuals search

<http://tv.somanuals.com>