



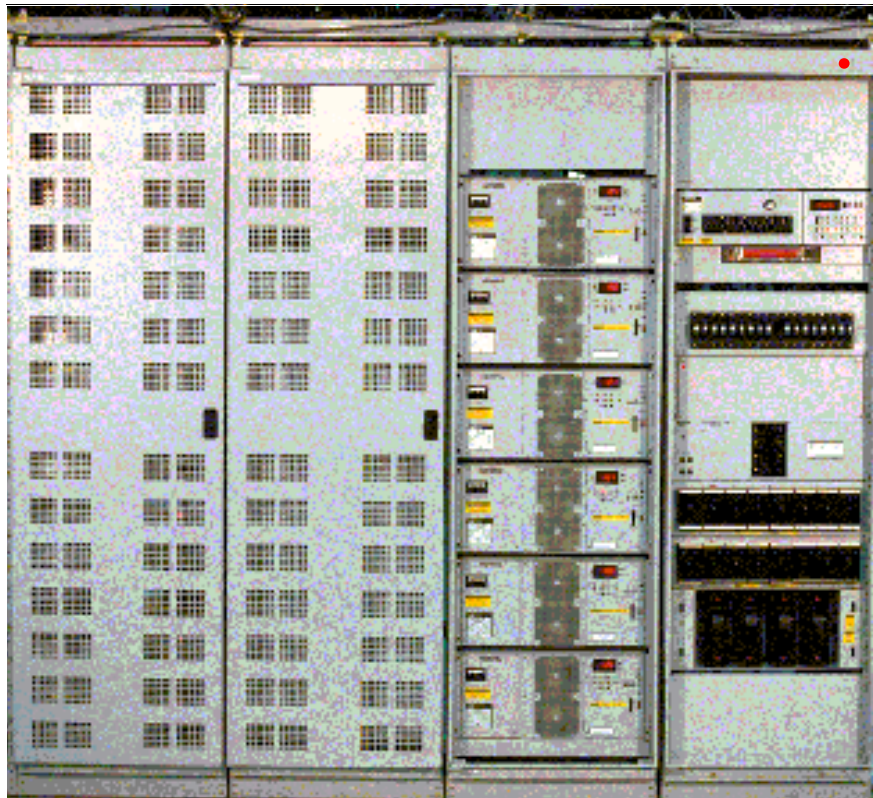
DC POWER

# Helios DC System 4000/48

1500, 3000, 4000 & 6000 A

DC Power System

**User  
Manual**



---

---

---

## TABLE OF CONTENTS

<b>1.0</b>	<b>ABOUT THIS DOCUMENT</b> .....	<b>1</b>
1.1	Purpose of This Document .....	1
1.2	Applicability of This Document .....	1
<b>2.0</b>	<b>INTRODUCTION</b> .....	<b>2</b>
2.1	Description .....	2
2.2	Applications .....	3
2.3	Control and Distribution Cabinets - Typical Configurations .....	4
<b>3.0</b>	<b>SPECIFICATIONS</b> .....	<b>6</b>
3.1	Framework .....	6
3.1.1	Mechanical Specifications of a Cabinet .....	6
3.1.2	Electrical Specifications of the Cabinets .....	6
3.2	Conventional Controller .....	7
3.2.1	Mechanical Specifications of the Conventional Controller .....	7
3.2.2	Electrical Specifications of the Conventional Controller .....	7
3.3	Distribution Panels .....	8
3.3.1	Fuse Panels .....	8
3.3.2	Circuit Breaker Panels .....	13
3.4	Externally Mounted Battery Return Busbar .....	18
3.4.1	Mechanical Specifications of the External Battery Return Busbar .....	18
3.4.2	Electrical Specifications of the External Battery Return Busbar .....	18
3.5	Terminating Assemblies (Optional) .....	19
3.6	MPS300 and MPA100 Power Shelves .....	20
3.6.1	Mechanical Specifications of the MPS300 and MPA100 Power Shelves .....	20
3.6.2	Electrical Specifications of the Power Shelves .....	21
3.7	Rectifiers .....	21
3.7.1	Helios Rectifier 100/48 .....	21
3.7.2	Helios Rectifiers 200I/48 and 200E/48 .....	22
3.7.3	Electrical Specifications of the Helios Rectifiers 200I/48 and 200E/48 .....	24
3.7.4	Standards .....	24
3.8	Helios Monitor 3000/48 (Optional) .....	25
3.8.1	Mechanical Specifications .....	25
3.8.2	Electrical Specifications .....	25
3.9	600 A and 1200 A Battery Disconnect Unit (Optional) .....	25
3.10	AC Junction Box .....	26
3.10.1	Mechanical Specifications .....	26
3.10.2	Electrical Specifications .....	26

---

3.11	Overall Power System Specifications .....	26
3.11.1	Standards .....	26
3.11.2	Mechanical Specifications of Fully Equipped Power Cabinets .....	26
3.11.3	Electrical Specifications .....	27
3.11.4	Environmental Specifications .....	27
3.11.5	Floor and Point Loading .....	27
<b>4.0</b>	<b>OPERATION .....</b>	<b>28</b>
4.1	General .....	28
4.2	Conventional Controller .....	28
4.2.1	Front Panel .....	28
4.2.2	Rear Panel .....	32
4.3	MPS300 and MPA100 Power Shelves .....	34
4.4	Rectifiers .....	35
4.5	AC Junction Box .....	35
4.6	Distribution Panels .....	35
4.7	Terminating Assemblies (Optional) .....	35
4.8	Helios Monitor 3000/48 (Optional) .....	36
4.9	600 A and 1200 Battery Disconnect Units (Optional) .....	36
<b>5.0</b>	<b>MAINTENANCE .....</b>	<b>37</b>
5.1	General .....	37
5.1.1	Helios Monitor 3000/48 .....	37
5.1.2	Controller and Rectifiers .....	37
5.2	Troubleshooting .....	39
5.3	Addition / Replacement Procedures .....	40
5.3.1	Addition or Replacement of a Rectifier .....	40
5.3.2	Replacing a Rectifier .....	45
5.3.3	Adding or Replacing a Battery String .....	47
5.3.4	Replacement of a Distribution Fuse Block or Circuit Breaker .....	48
5.3.5	Replacing a Cabinet Alarm Lamp .....	48
<b>6.0</b>	<b>REFERENCE DOCUMENTS .....</b>	<b>49</b>
<b>7.0</b>	<b>LIST OF TERMS .....</b>	<b>50</b>

---

## FIGURES

Figure 1	Front view of a typical bottom fed 4000 A Helios DC System 4000/48 power system . . . . .	2
Figure 2	Front view of a typical 6000 A Helios DC System 4000/48 power system . . . . .	3
Figure 3	Typical configurations for Helios DC System 4000/48 control, distribution and rectifier cabinets . . . . .	4
Figure 4	Front view of the Conventional Controller . . . . .	7
Figure 5	Front view of the 20 QFF 0-5 A fuse panels . . . . .	8
Figure 6	Front view of the (16) QFF 0-5 A & (12) ABS 5-30 A fuse panels . . . . .	9
Figure 7	Front view of the (16) QFF 0-5 A & (6) TPN 5-30 A fuse panels . . . . .	9
Figure 8	Front view of the (8) TPN 5-30 A fuse panels . . . . .	10
Figure 9	Front view of the (4) RS100P 70-100 A fuse panels . . . . .	10
Figure 10	Front view of the (4) CRS200P 150-200 A/ (4) CRS200P 150-200 A (w/load shunts) fuse panels . . . . .	11
Figure 11	Front view of the (4) TPL 225-600 A fuse panels . . . . .	11
Figure 12	Front view of the (18) TPS 1-70 A fuse panel . . . . .	12
Figure 13	Front view of the (24) Plug-In 1-100 A circuit breaker panel . . . . .	14
Figure 14	Front view of the (4) 70-250 A circuit breaker panel . . . . .	15
Figure 15	Front view of the (2) 400 A circuit breaker panel . . . . .	16
Figure 16	Front view of the (1) 600-700 A circuit breaker panel . . . . .	16
Figure 17	Top and side views of the external battery return busbar . . . . .	18
Figure 18	Perspective view of the a terminating assemblies . . . . .	19
Figure 19	Front view of the MPS300 power shelf (shown empty) . . . . .	20
Figure 20	Front view of the MPA100 power shelf (shown empty) . . . . .	21
Figure 21	Front view of the Helios Rectifier 100/48 . . . . .	21
Figure 22	Front view of the Helios Rectifiers 200I/48 and 200E/48 . . . . .	23
Figure 23	Front view of the Helios Monitor 3000/48 (without the mounting brackets) . . . . .	25
Figure 24	600 A Battery Disconnect Unit . . . . .	25
Figure 25	Front view of the AC junction box (with the front panel open) . . . . .	26
Figure 26	Front view of the Conventional Controller . . . . .	28
Figure 27	Shunt range selection settings. . . . .	30
Figure 28	Equalize voltage and duration settings. . . . .	31
Figure 29	Terminal blocks and connectors layout at the rear of the Conventional Controller. . . . .	32
Figure 30	Wiring diagram and pin assignment of terminal blocks TB1 to TB4 . . . . .	33
Figure 31	Wiring diagram and pin assignment of terminal blocks TB5 and TB6, and connectors P1 to P26. . . . .	34
Figure 32	AC connections in a Helios Rectifier 200E/48. . . . .	42
Figure 33	AC connections in the female receptacle for a Helios Rectifier 200I/48 or a Helios Rectifier 200E/48 . . . . .	43
Figure 34	AC connections inside the junction box (top fed shown) for a Helios Rectifier 200E/48. . . . .	43
Figure 35	AC cable routing for the Helios Rectifiers 200E/48 in a top fed system . . . . .	44
Figure 36	AC cable routing for the Helios Rectifiers 200E/48 in a bottom fed system . . . . .	44

---

## TABLES

Table 1	Rectifier cabinets . . . . .	5
Table 2	Control and distribution cabinets . . . . .	5
Table 3	Auxiliary distribution cabinets . . . . .	5
Table 4	Mechanical specifications of the cabinet (empty) . . . . .	6
Table 5	Mechanical specifications of the Conventional Controller . . . . .	7
Table 6	Mechanical specifications of the fuse panels . . . . .	8
Table 7	Fuse sizes available for the (20) QFF 0-5 A fuse panels . . . . .	8
Table 8	Fuse sizes available for the (16) QFF 0-5 A & (12) ABS 5-30 A fuse panels . . . . .	9
Table 9	Fuse sizes available for the (16) QFF 0-5 A & (6) TPN 5-30 A fuse panels . . . . .	9
Table 10	Fuse sizes available for the (8) TPN 5-30 A fuse panels . . . . .	10
Table 11	Fuse sizes available for the (4) RS100P 70-100 A fuse panels . . . . .	10
Table 12	Fuse sizes available for the (4) CRS200P 150-200 A/ (4) CRS200P 150-200 A (w/load shunts) fuse panels . . . . .	11
Table 13	Fuse sizes available for the (4) TPL 225-600 A fuse panels . . . . .	11
Table 14	Fuse sizes available for the (18) TPS 1-70 A fuse panel . . . . .	12
Table 15	Electrical specifications of the fuse panels . . . . .	13
Table 16	Mechanical specifications of the circuit breaker panels . . . . .	13
Table 17	Plug-in circuit breakers available for the (24) Plug-In 1-100 A circuit breaker panel . . . . .	14
Table 18	Circuit breaker sizes available for the (4) 70-250 A circuit breaker panel . . . . .	15
Table 19	Circuit breaker kits available for the (2) 400 A circuit breaker panel . . . . .	16
Table 20	Circuit breaker kits available for the (1) 600-700 A circuit breaker panel . . . . .	16
Table 21	Electrical specifications of the circuit breaker panels . . . . .	17
Table 22	Mechanical specifications of a single lamination . . . . .	18
Table 23	Mechanical specifications of the MPS300 and MPA100 power shelves . . . . .	20
Table 24	Mechanical specifications of the Helios Rectifier 100/48 . . . . .	21
Table 25	Electrical specifications of the Helios Rectifier 100/48 . . . . .	22
Table 26	Mechanical specifications of the Helios Rectifiers 200I/48 and 200E/48 . . . . .	22
Table 27	Electrical specifications of the Helios Rectifiers 200I/48 and 200E/48 . . . . .	24
Table 28	Mechanical specifications of the Helios Monitor 3000/48 . . . . .	25
Table 29	Mechanical specifications of the AC junction box . . . . .	26
Table 30	Mechanical specifications of fully equipped power cabinets . . . . .	26
Table 31	Floor and point loading . . . . .	27
Table 32	Visual indicators . . . . .	28
Table 33	Transmitted alarms . . . . .	29
Table 34	Potentiometers . . . . .	29
Table 35	Switches . . . . .	30
Table 36	DIP switch modules . . . . .	30
Table 37	Fuse . . . . .	31
Table 38	Test points . . . . .	31
Table 39	Fault diagnosis . . . . .	39

---

## **1.0 ABOUT THIS DOCUMENT**

---

### **1.1 Purpose of This Document**

This document provides all the necessary information to operate and maintain a Helios DC System 4000/48 power system.

The installation procedures for the Helios DC System 4000/48 power system are covered in installation manual SL-60034.

### **1.2 Applicability of This Document**

This document applies to Helios DC System 4000/48 power systems having any configuration of equipment.

---

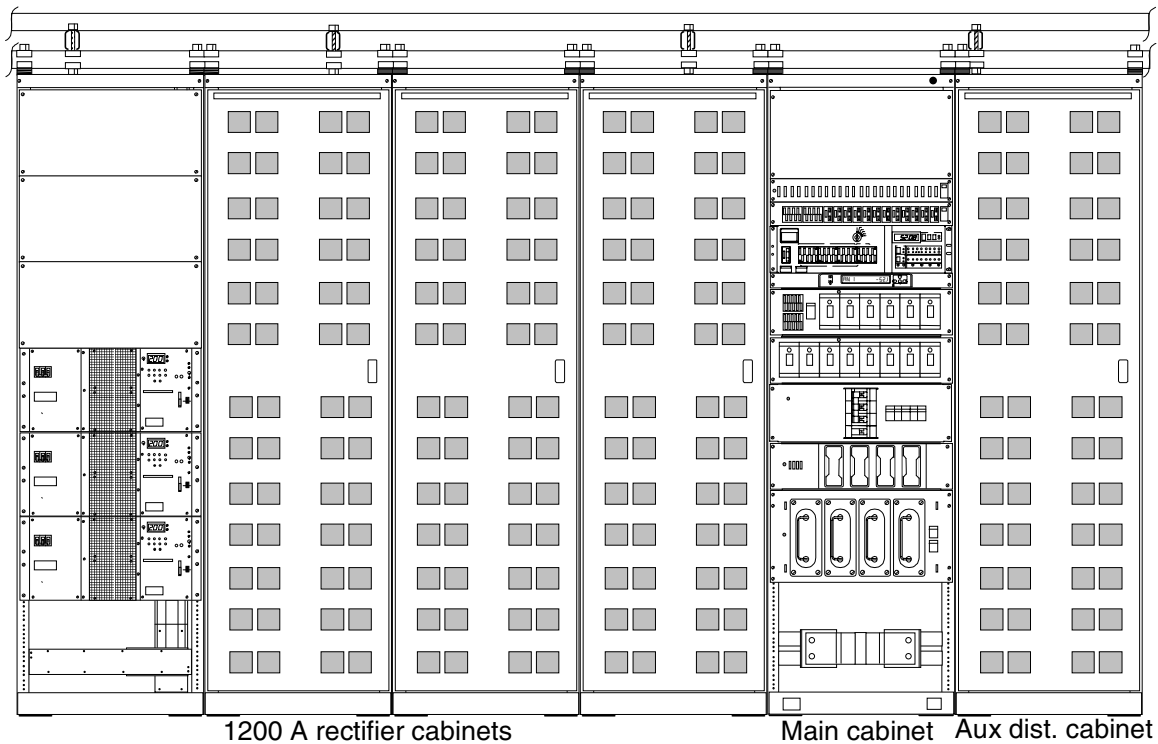
## 2.0 INTRODUCTION

---

### 2.1 Description

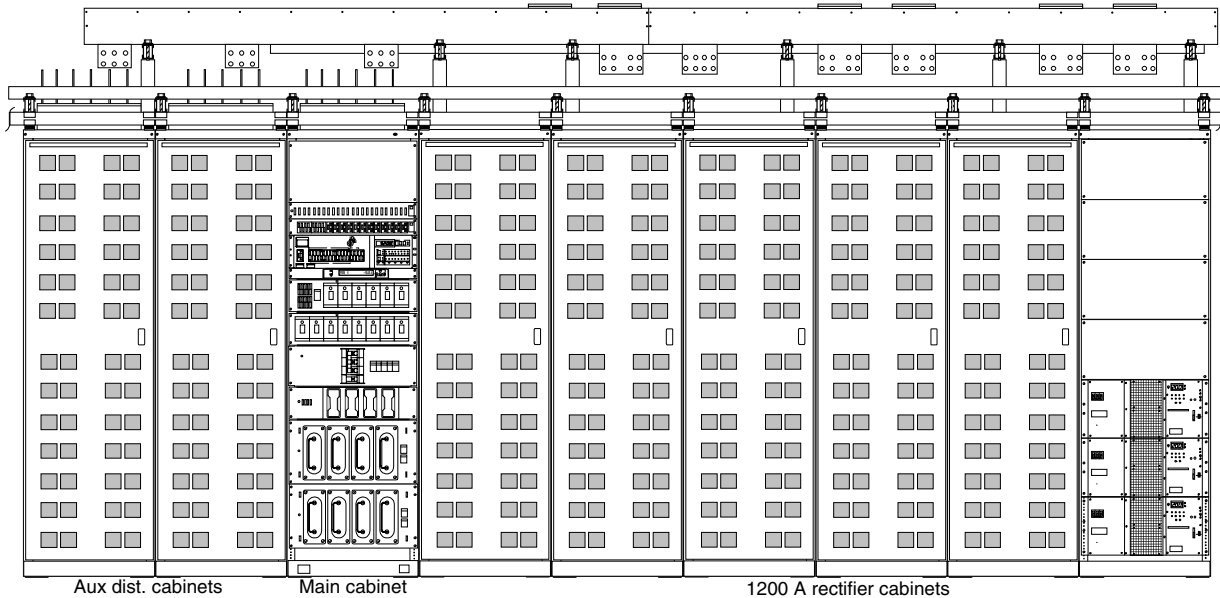
The Helios DC System 4000/48 is a positive ground, -48 V DC nominal power system consisting of one control and distribution cabinet and one or more rectifier cabinets. It is available in capacities of 1500, 3000, 4000 and 6000 A. Auxiliary distribution cabinets can be added as required for additional distribution. Remote monitoring, temperature compensation and battery disconnect options are also available. The 1500, 3000 and 4000 A versions use internal -48 V bussing and external BR+ bussing, while the 6000 A version uses overhead bussing. **Figure 1** shows a typical bottom fed 4000 A system, while **Figure 2** shows a typical 6000 A system.

**Figure 1 Front view of a typical bottom fed 4000 A Helios DC System 4000/48 power system**





**Figure 2 Front view of a typical 6000 A Helios DC System 4000/48 power system**



Cables are used for inter-cabinet connections (1500, 3000 and 6000 A systems) or connections to the overhead busbars (6000 A system) for ease of expansion on live systems. In a 1500, 3000 or 4000 A systems, the power system battery return (BR) busbar is mounted externally from the cabinet to facilitate the connections of the battery return cables. In a 6000 A system, a separate BR busbar dedicated to the battery returns for the loads is mounted externally from the overhead busbar duct to facilitate the connections of the load battery return cables.

The Helios DC System 4000/48 provides a variety of monitoring and alarm features, such as high/low float and high/low voltage alarm, high voltage shutdown, fuse and breaker alarm and rectifier failure alarms.

The Helios DC System 4000/48 uses Helios Rectifiers 200I/48, Helios Rectifiers 200E/48 or Helios Rectifiers 100/48 connected in parallel as building blocks to reach the maximum capacities. The Helios Rectifiers 200I/48 operate from a 380 V to 415 V three phase, 50 or 60 Hz AC source. The Helios Rectifiers 200E/48 operate from a 480 V three phase, 50 or 60 Hz AC source. The Helios Rectifiers 100/48 operate from a 208 V to 240 V single phase, 50 or 60 Hz AC source.

The 1200 A rectifier cabinet accepts up to six Helios Rectifiers 200I/48 or 200E/48, while the 1000 A rectifier cabinet accepts up to 10 Helios Rectifiers 100/48.

The control and distribution cabinet and the auxiliary distribution cabinets are available with distribution busbar risers of 2000 A or 3000 A capacity.

The cabinets are seismic qualified to zone 4 (Bellcore) when anchored to a concrete floor whose compressive strength is at least  $2.11 \text{ kg/mm}^2$  (3000 psi) and when equipped with a seismic kit. The cabinets are seismic qualified to zone 2 without the seismic kit.

The cabinets are equipped with a ventilated, lockable door, a ventilated top cover and two rear ventilated panels.

In many applications, such as with DMS, a consistent single-point ground (SPG) topology must be maintained for all associated equipment. The Helios DC System 4000/48 complies with this requirements for single-point grounding (the isolation kit is required).

## 2.2 Applications

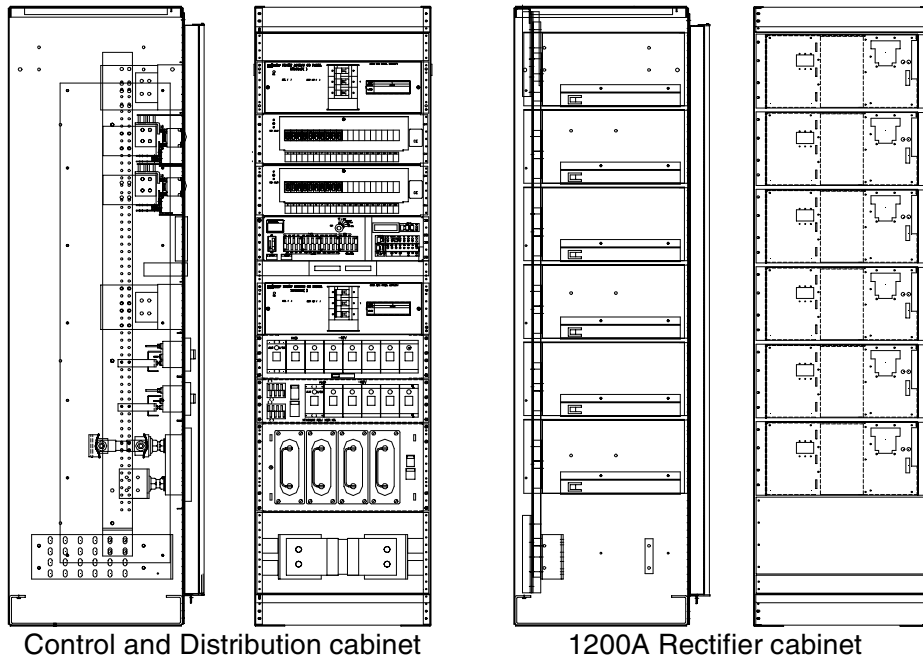
The Helios DC System 4000/48 is designed to operate with DMS systems or any other telecommunication systems whose input is nominal -48 V DC and whose current requirements do not exceed 6000 A capacity.

---

## 2.3 Control and Distribution Cabinets - Typical Configurations

Figure 3 shows the front and side views of typical rectifier and distribution cabinets for a Helios DC System 4000/48 (bottom cabled cabinets are illustrated - top cabled versions are available).

Figure 3 Typical configurations for Helios DC System 4000/48 control, distribution and rectifier cabinets



Cabinets are available in a variety of configurations as listed in the following tables. Note that for a 6000 A system, the cabling is always at the top.

**Table 1 Rectifier cabinets**

Cabinet Capacity	Rectifier		Cabled top or bottom
	Type	Qty	
1200 A	Helios Rectifier 200I	6	Top
1200 A	Helios Rectifier 200I	6	Bottom
1000 A	Helios Rectifier 100/48	10	Top or bottom
1200 A	Helios Rectifier 200E	6	Top
1200 A	Helios Rectifier 200E	6	Bottom
1200 A	Helios Rectifier 200E	6	Top
1200 A	Helios Rectifier 200E	6	Bottom

**Table 2 Control and distribution cabinets**

Nominal cabinet capacity	Shunt capacity	Riser busbar capacity	Cabled top or bottom
1500 A	2500 A	2000 A	Top
3000 A	4000 A	3000 A	Top
4000 A	5000 A	3000 A	Top
1500 A	2500 A	2000 A	Bottom
3000 A	4000 A	3000 A	Bottom
4000 A	5000 A	3000 A	Bottom

For a 6000 A system, the charge busbars and the shunt are mounted externally from the control and distribution cabinet.

**Table 3 Auxiliary distribution cabinets**

Nominal cabinet capacity	Top busbar capacity	Riser busbar capacity	Cabled top or bottom
2000 A	3000 A	2000 A	Top
2000 A	3000 A	2000 A	Bottom
3000 A	4000 A	3000 A	Top
3000 A	4000 A	3000 A	Bottom

---

## 3.0 SPECIFICATIONS

---

### 3.1 Framework

The Helios DC System 4000/48 uses cabinet type frameworks. The same cabinet design is used for the main control and distribution cabinet, the auxiliary distribution cabinets and the rectifier cabinets. The cabinet is always equipped with a front door and door frame (lockable, equipped with ground straps, and easily removable for installation or maintenance access), a ventilated top cover made of non-flammable plastic, and two ventilated rear cover panels (equipped with ground strap and easily removable for installation and maintenance access). Bussing and equipment (controller, rectifiers, distribution panels, etc.) are added as required, depending on the use of the cabinet. Seismic bracing is also available as options.

When using the Cable Trough, overhead cabling cannot enter from the front or rear of the system. It must be confined to the system foot print and enter at the ends of the lineup.

The cabinets may be either top or bottom cabled as determined by the location of the bussing.

#### 3.1.1 Mechanical Specifications of a Cabinet

The mechanical specifications of an empty cabinet are listed in **Table 4**.

**Table 4 Mechanical specifications of the cabinet (empty)**

Framework type	Height	Depth	Width	Weight
Cabinet	2134 mm (84.0 in.)	600 mm (23.6 in.)	600 mm (23.6 in.)	114 kg (251 lb)

Refer to **Figure 3** for typical views of cabinets.

#### 3.1.2 Electrical Specifications of the Cabinets

The electrical specifications of equipped cabinets are as follows:

- The main control and distribution cabinet for a 1500 A system has a 2000 A busbar riser and a common equipment panel e/w one 1500 A CHG and DISCH busbar and a 2500 A system shunt.
- The main control and distribution cabinet for a 3000A system has a 3000 A busbar riser and a common equipment panel e/w two 1500 A CHG and DISCH busbars and a 4000 A system shunt.
- The main control and distribution cabinet for a 4000A system has a 3000 A busbar riser and a common equipment panel e/w three 1500 A CHG and DISCH busbars and a 5000 A system shunt.
- A 6000 A system has a 3000 A busbar riser in the main control and distribution cabinet (the CHG and DISCH busbar and the shunt are external).
- The auxiliary distribution cabinet is available with a 2000 or 3000 A busbar riser.
- A 1200 A rectifier cabinet has 1500 A busbar risers for the DC output of the rectifiers.



### 3.3 Distribution Panels

#### 3.3.1 Fuse Panels

##### Mechanical specifications of the fuse panels

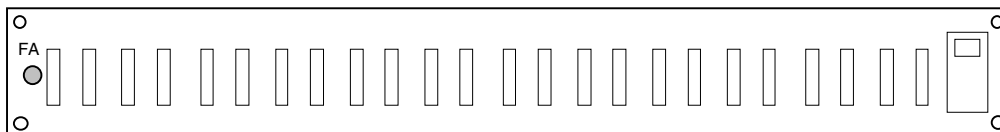
The mechanical specifications of the fuse panels are listed in **Table 6** below.

**Table 6 Mechanical specifications of the fuse panels**

Panel description	Figure	Height	Width	Weight
(20) QFF 0-5 A 60 A max	<b>Figure 5</b>	76.2 mm (3.0 in.)	584 mm (23.0 in.)	3 kg (6.6 lb)
(16) QFF 0-5 A & (12) ABS 5-30 A 300 A max	<b>Figure 6</b>	76.2 mm (3.0 in.)	584 mm (23.0 in.)	5 kg (11.0 lb)
(16) QFF 0-5 A & (6) TPN 5-30 A 250 A max	<b>Figure 7</b>	152.4 mm (6.0 in.)	584 mm (23.0 in.)	7 kg (15.4 lb)
(8) TPN 5-30 A 250 A max	<b>Figure 8</b>	152.4 mm (6.0 in.)	584 mm (23.0 in.)	7 kg (15.4 lb)
(4) RS100P 70-100 A 300 A max	<b>Figure 9</b>	152.4 mm (6.0 in.)	584 mm (23.0 in.)	8 kg (17.8 lb)
(4) CRS200P 150-200 A 600 A max	<b>Figure 10</b>	228.6 mm (9.0 in.)	584 mm (23.0 in.)	22 kg (48.4 lb)
(4) CRS200P 150-200 A (w/load shunts) 600 A max	<b>Figure 10</b>	228.6 mm (9.0 in.)	584 mm (23.0 in.)	24 kg (52.9 lb)
(4) TPL 225-600 A 1600 A max	<b>Figure 11</b>	304.8 mm (12.0 in.)	584 mm (23.0 in.)	32 kg (70.4 lb)
(18) TPS 1-70 A 600 A max	<b>Figure 12</b>	178 mm (7.0 in.)	584 mm (23.0 in.)	35 kg (77.0 lb)

*Note 1:* An alarm circuit pack with an alarm indication LED is standard on all panels  
*Note 2:* (4) CRS200P 150-200 A (w/load shunts) is equipped with four shunts.

**Figure 5 Front view of the 20 QFF 0-5 A fuse panels**

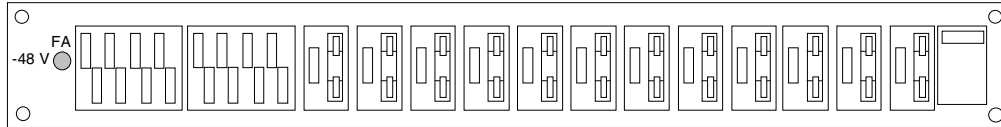


The DC output connections are wire wrap or solder.

**Table 7 Fuse sizes available for the (20) QFF 0-5 A fuse panels**

Fuse type	Current (A)	CPC
QFF1A	1.333	A0205202
QFF1B	2	A0205203
QFF1C	3	A0205204
QFF1D	5	A0205205
QFF1E	0.18	A0205206
QFF1F	0.25	A0205207
QFF1G	0.5	A0205208
QFF1H	0.75	A0205209
QFF3A	DUMMY	A0205210

**Figure 6 Front view of the (16) QFF 0-5 A & (12) ABS 5-30 A fuse panels**

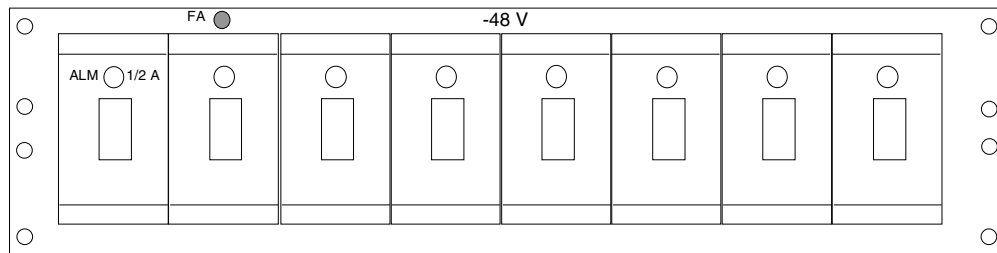


The DC output connections are No. 8-32 studs equipped with two hex nuts.

**Table 8 Fuse sizes available for the (16) QFF 0-5 A & (12) ABS 5-30 A fuse panels**

Fuse type	Current (A)	CPC
4AB (ABS)	5	A0327000
	8	A0111415
	10	A0315462
	12	A0267003
	15	A0344157
	20	A0314873
	25	A0243206
	30	A0328460
QFF1A	1.333	A0205202
QFF1B	2	A0205203
QFF1C	3	A0205204
QFF1D	5	A0205205
QFF1E	0.18	A0205206
QFF1F	0.25	A0205207
QFF1G	0.5	A0205208
QFF1H	0.75	A0205209
QFF3A	DUMMY	A0205210

**Figure 7 Front view of the (16) QFF 0-5 A & (6) TPN 5-30 A fuse panels**

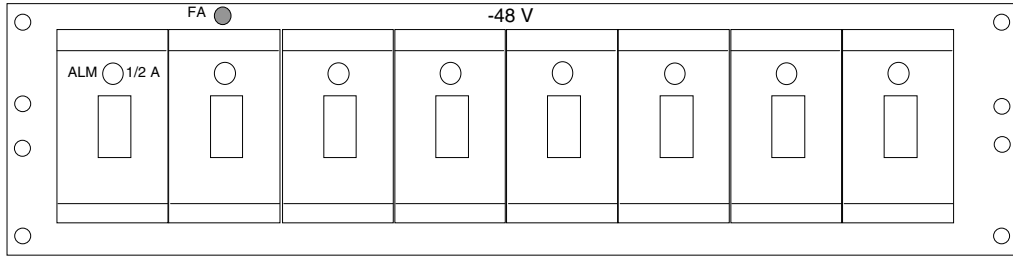


The DC output connections are 0.250-20 studs equipped with two hex nuts.

**Table 9 Fuse sizes available for the (16) QFF 0-5 A & (6) TPN 5-30 A fuse panels**

Fuse type	Current (A)	CPC
DC power (TPN)	1	A0380108
	3	A0380109
	6	A0380111
	10	A0380112
	15	A0380113
	20	A0380147
	25	A0380148
	30	A0380149

**Figure 8 Front view of the (8) TPN 5-30 A fuse panels**

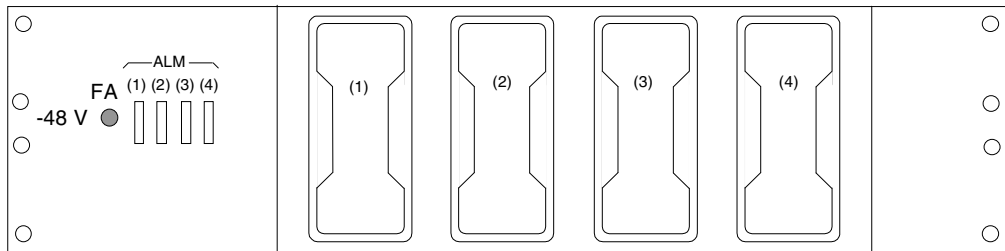


The DC output connections are 0.250-20 studs equipped with two hex nuts.

**Table 10 Fuse sizes available for the (8) TPN 5-30 A fuse panels**

Fuse type	Current (A)	CPC
DC power (TPN)	35	A0380150
	40	A0380151
	45	A0380152
	50	A0380114
	60	A0380115

**Figure 9 Front view of the (4) RS100P 70-100 A fuse panels**



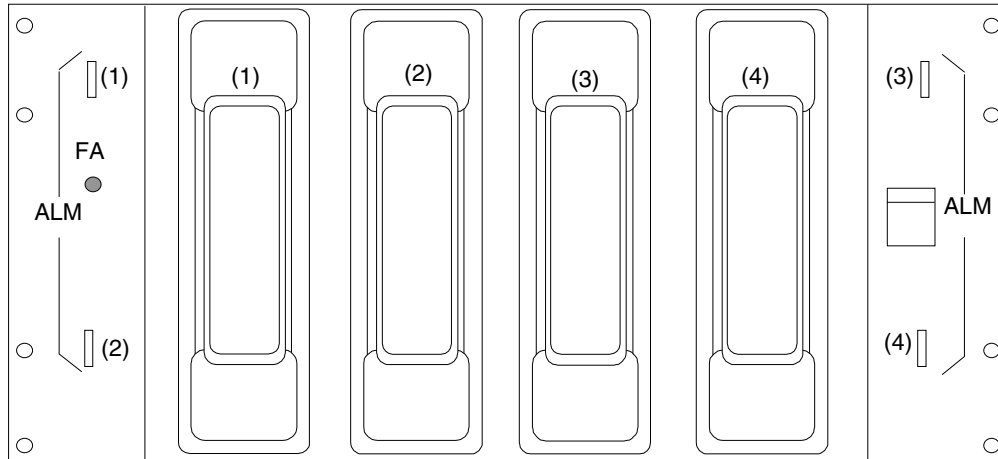
The DC output connections are 0.375-16 studs equipped with two hex nuts.

**Table 11 Fuse sizes available for the (4) RS100P 70-100 A fuse panels**

Fuse type	Current (A)	CPC
HRC1-K	70	A0722046
	80	A0722045
	90	A0722044
	100	A0722049



**Figure 10 Front view of the (4) CRS200P 150-200 A/(4) CRS200P 150-200 A (w/load shunts) fuse panels**

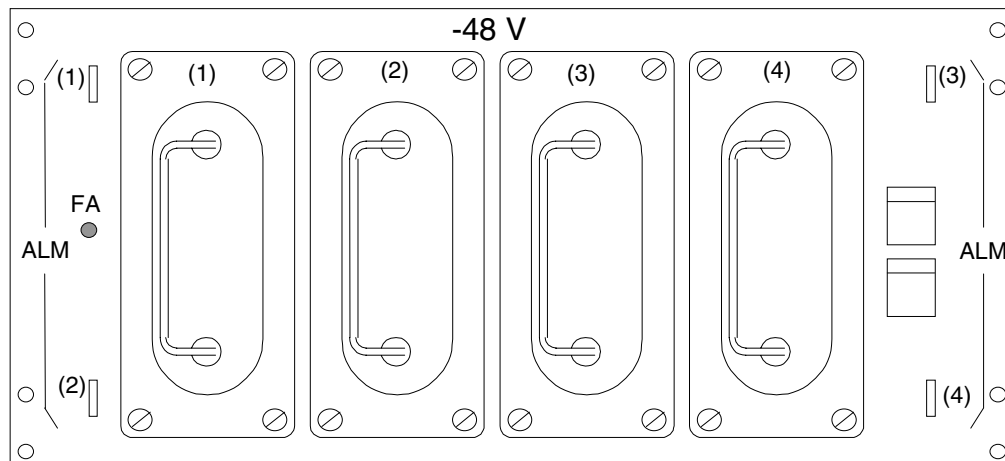


The DC output connections are 0.50-13 studs equipped with two hex nuts.

**Table 12 Fuse sizes available for the (4) CRS200P 150-200 A/(4) CRS200P 150-200 A (w/load shunts) fuse panels**

Fuse type	Current (A)	CPC
HRC1-J	110	A0329697
	125	A0329696
	150	A0722041
	175	A0722038
	200	A0614832

**Figure 11 Front view of the (4) TPL 225-600 A fuse panels**

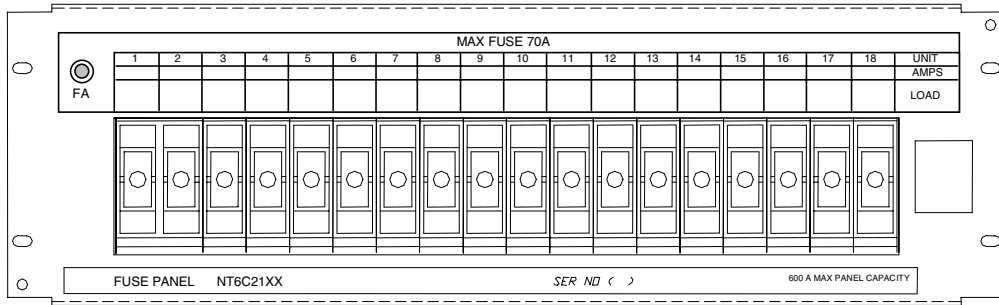


The DC output connections are busbar angles that can accept 535MCM or 750MCM cables, or the metric equivalent. The lugs must be for two 1/2" dia. bolts at 1-3/4" c-c.

**Table 13 Fuse sizes available for the (4) TPL 225-600 A fuse panels**

Fuse type	Current (A)	CPC
DC power (TPL)	225	A0380138
	300	A0380140
	400	A0380141
	500	A0380142
	600	A0380143

**Figure 12 Front view of the (18) TPS 1-70 A fuse panel**



Can accept maximum 1/0 AWG cables and requires one-hole lugs for 1/4" diameter studs.

**Table 14 Fuse sizes available for the (18) TPS 1-70 A fuse panel**

Fuse type	Current (A)	CPC
<b>DC power (TPS)</b>	1	A0601322
	3	A0601323
	5	A0601325
	6	A0601326
	10	A0601327
	15	A0601328
	25	A0601330
	30	A0601331
	40	A0601332
	50	A0601333
	60	A0601334
	70	A0601335

## Electrical specifications of the fuse panels

The electrical specifications of the fuse panels are described in **Table 15**.

**Table 15 Electrical specifications of the fuse panels**

Panel number	Figure	Fuses		Busbar capacity
		Quantity	Capacity	
(20) QFF 0-5 A 60 A max	<b>Figure 5</b>	20	0-5 A	60 A
(16) QFF 0-5 A & (12) ABS 5-30 A 300 A max	<b>Figure 6</b>	16 12	0-5 A 0-30 A	300 A
(16) QFF 0-5 A & (6) TPN 5-30 A 250 A max	<b>Figure 7</b>	8	0-30 A	250 A
(8) TPN 5-30 A 250 A max	<b>Figure 8</b>	8	31-60 A	300 A
(4) RS100P 70-100 A 300 A max	<b>Figure 9</b>	4	70-100 A	300 A
(4) CRS200P 150-200 A 600 A max  (4) CRS200P 150-200 A (w/load shunts) 600 A max	<b>Figure 10</b>	4	101-200 A	600 A
(4) TPL 225-600 A 1600 A max	<b>Figure 11</b>	4	225-600 A	1600 A
(18) TPS 1-70 A 600 A max	<b>Figure 12</b>	18	0-70 A	600 A

### 3.3.2 Circuit Breaker Panels

#### Mechanical specifications of the circuit breaker panels

The mechanical specifications of the circuit breaker panels are described in **Table 16**.

**Table 16 Mechanical specifications of the circuit breaker panels**

Panel description	Figure	Height	Width	Weight
(24) Plug-In 1-100 A 900 A max	<b>Figure 13</b>	165 mm (6.5 in.)	584 mm (23.0 in.)	9.1kg (20 lb.)
(4) 70-250 A 900 A max *	<b>Figure 14</b>	178 mm (7.0 in.)	584 mm (23.0 in.)	10.5 kg (25 lb)
(2) 400 A	<b>Figure 15</b>	178 mm (7.0 in.)	584 mm (23.0 in.)	10.5 kg (25 lb)
(1) 600-700 A	<b>Figure 16</b>	178 mm (7.0 in.)	584 mm (23.0 in.)	10.5 kg (25 lb)

\* The 250 A circuit breaker has two poles, thus the panel can accommodate a maximum of two 250 A breakers.  
An alarm circuit pack with an alarm indication LED is standard on all panels.

**Figure 13 Front view of the (24) Plug-In 1-100 A circuit breaker panel**



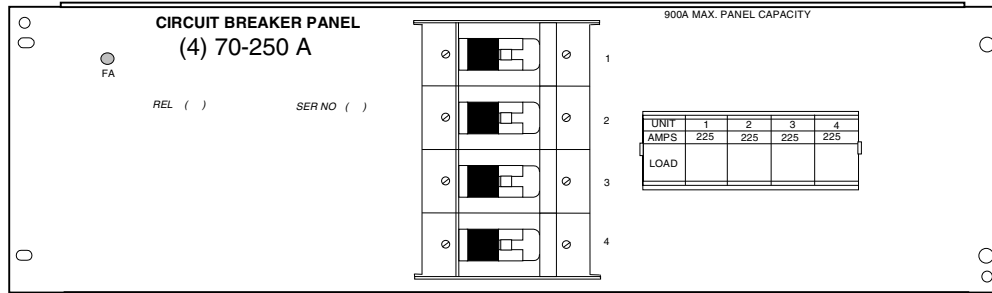
The DC output connections vary according to the circuit breaker capacity: maximum cable size is 2/0AWG. The lugs must be for 3/8" dia. bolts at 1" c-c.

Refer to **Table 21** for the maximum panel capacity.

**Table 17 Plug-in circuit breakers available for the (24) Plug-In 1-100 A circuit breaker panel**

Nominal current	CPC Std Trip	CPC Mid Trip
1 A	A0723076	A0722751
5 A	A0723033	A0722752
10 A	A0723035	A0722754
15 A	A0723037	A0722755
20 A	A0723007	A0722695
25 A	A0723039	A0722707
30 A	A0723040	A0722715
35 A	A0723041	A0722717
40 A	A0723042	A0722721
45 A	A0723069	A0722722
50 A	A0723008	A0722726
60 A	A0723070	A0722727
65 A	A0723071	A0722497
70 A	A0723072	A0722732
80 A	A0723074	A0722733
90 A	A0723077	A0722750
100 A	A0723009	A0722496

**Figure 14 Front view of the (4) 70-250 A circuit breaker panel**



The DC output connections can accommodate two 4/0 cables back to back for each circuit breaker. The required lugs can be either for two 3/8" holes at 1" c-c or for two 1/2" holes at 1-3/4" c-c.

Refer to **Table 21** for the maximum panel capacity.

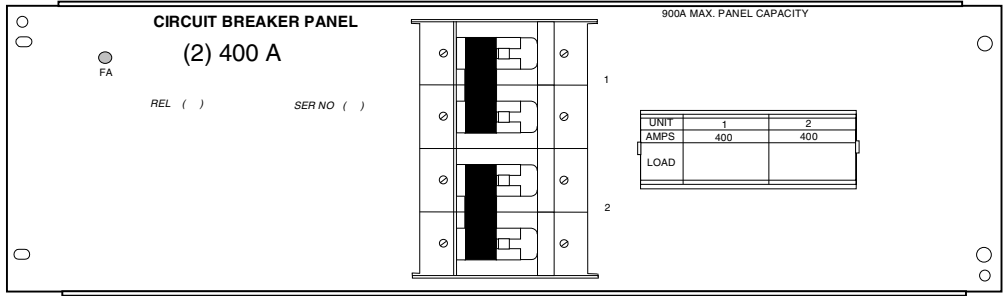
**Table 18 Circuit breaker sizes available for the (4) 70-250 A circuit breaker panel**

Nominal current	CPC
70 A (no shunt)	A0617079
70 A (with shunt)	A0617080
70 A (with relay trip)	A0617081
100 A (no shunt)	A0616667
100 A (with shunt)	A0616668
100 A (with relay trip)	A0616669
150 A (no shunt)	A0616670
150 A (with shunt)	A0616671
150 A (with relay trip)	A0616672
200 A (no shunt)	A0616673
200 A (with shunt)	A0616674
200 A (with relay trip)	A0616675
225 A (no shunt)	A0605489
225 A (with shunt)	A0605490
225 A (with relay trip)	A0605492
250 A (no shunt)	A0616676
250 A (with shunt)	A0616677
250 A (with relay trip)	A0616678

The (4) 70-250 A circuit breaker panel can accept up to:

- four breakers (70 to 225 A) mid trip with or without the metering shunt option (1 pole breakers)
- two breakers (70 to 225 A) mid trip with the relay trip option (takes a 2 pole space)
- two breakers (250 A) mid trip with or without the metering shunt option (takes a two pole breaker)
- one (250 A) breaker mid trip with the relay trip option (takes a 3 pole space)

**Figure 15 Front view of the (2) 400 A circuit breaker panel**



The DC output connections can accommodate two 750 MCM cables back to back for each circuit breaker. The required lugs must be for two 1/2" holes at 1-3/4" c-c.

Refer to **Table 21** for the maximum panel capacity.

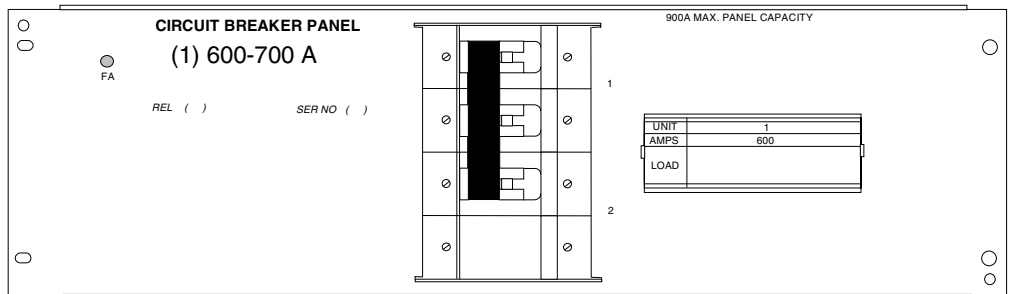
**Table 19 Circuit breaker kits available for the (2) 400 A circuit breaker panel**

Nominal current	CPC
400 A (no shunt)	P0748316
400 A (with shunt)	P0748317
2 x 400 A (no shunt)	P0748318
2 x 400 A (with shunt)	P0748319
400 A (with relay trip)	P0748320

The panel accepts up to:

- two breakers (400 A) mid trip with or without the metering shunt option
- one breaker (400 A) mid trip with the relay trip option (takes a 3 pole space)

**Figure 16 Front view of the (1) 600-700 A circuit breaker panel**



The DC output connections can accommodate four 750 MCM cables back to back. The lugs must be for two 1/2" bolts at 1-3/4" c-c.

Refer to **Table 21** for the available circuit breakers and the maximum panel capacity.

**Table 20 Circuit breaker kits available for the (1) 600-700 A circuit breaker panel**

Nominal current	CPC
600 A (no shunt)	P0875700
600 A (e/w shunt)	P0875701
600 A (e/w relay trip)	P0875702

---

## Electrical specifications of the circuit breaker panels

The electrical specifications of the circuit breaker panels are described in **Table 21**.

**Table 21** Electrical specifications of the circuit breaker panels

Panel description	Figure	Circuit breakers		Busbar capacity
		Max. Quantity	Capacity	
(24) Plug-In 1-100 A 900 A max	<b>Figure 13</b>	24	1-100 A	900A
(4) 70-250 A 900 A max	<b>Figure 14</b>	4	70-250 A	900 A
(2) 400 A	<b>Figure 15</b>	2	400 A	900 A
(1) 600-700 A	<b>Figure 16</b>	1	600 A	900 A

### 3.4 Externally Mounted Battery Return Busbar

The battery return busbar is designed to mount on the overhead racking for 6000 A systems and top cabled 1500, 3000 or 4000 A power systems. It can also be mounted on a wall or on the floor below the raised floor for bottom cabled 1500, 3000 or 4000 A power systems (which are assumed to be installed on a raised, computer type floor).

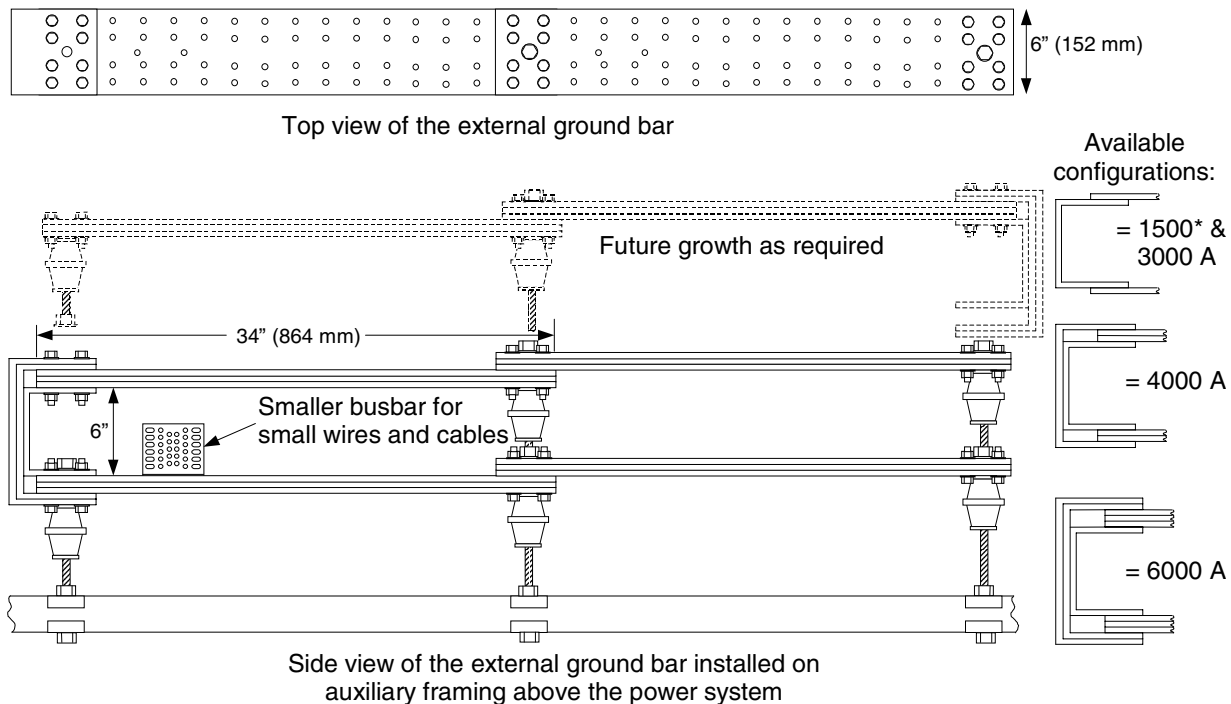
#### 3.4.1 Mechanical Specifications of the External Battery Return Busbar

The external battery return busbar kit consists of a group of single busbar laminations and attachment hardware assembled as shown in **Figure 17** (6000 A shown). The kit can grow vertically in such a way as to maintain the 3-ft maximum radius grounding requirement. Laminations are added as required to increase the capacity. The mechanical specifications of a single lamination are listed in **Table 22**.

**Table 22 Mechanical specifications of a single lamination**

Figure	Length	Width	Thickness
Figure 17	863.6 mm (34 inches)	152.4 mm (6 inches)	12.7 mm (0.5 inches)

**Figure 17 Top and side views of the external battery return busbar**



#### 3.4.2 Electrical Specifications of the External Battery Return Busbar

A single busbar lamination has a current carrying capacity of 3000 A.



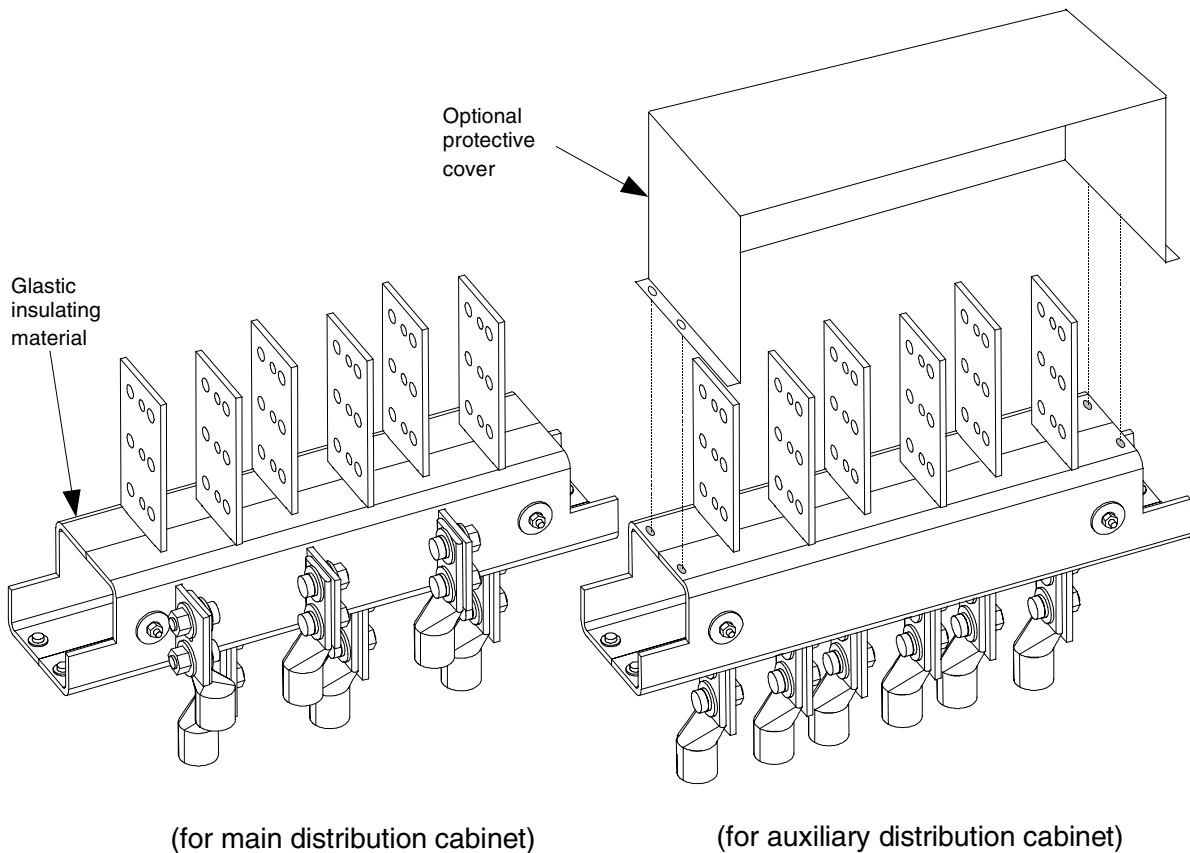
### 3.5 Terminating Assemblies (Optional)

The optional terminating assembly allows top access connections for up to six loads. Refer to **Figure 18**. Each load position is rated at 600 A and can accept up to three lugs having 1" or 1-3/4" c-c hole spacing, for cables up to 777 kcmil.

The terminating assembly is bolted to the top of the main or auxiliary distribution cabinets and, therefore, increase the cabinet height by 12 inches. The weight of the terminating assembly is 12.5 kg (27.6 lb).

An optional Lexan™ protective cover is available to protect the connections of the load cables.

**Figure 18** Perspective view of the a terminating assemblies



### 3.6 MPS300 and MPA100 Power Shelves

The MPS300 and MPA100 power shelves are required for the Helios Rectifier 100/48, which is a plug-in type rectifier. The MPA100 power shelf supports one Helios Rectifier 100/48, while the MPS300 shelf can support up to three Helios Rectifiers 100/48.

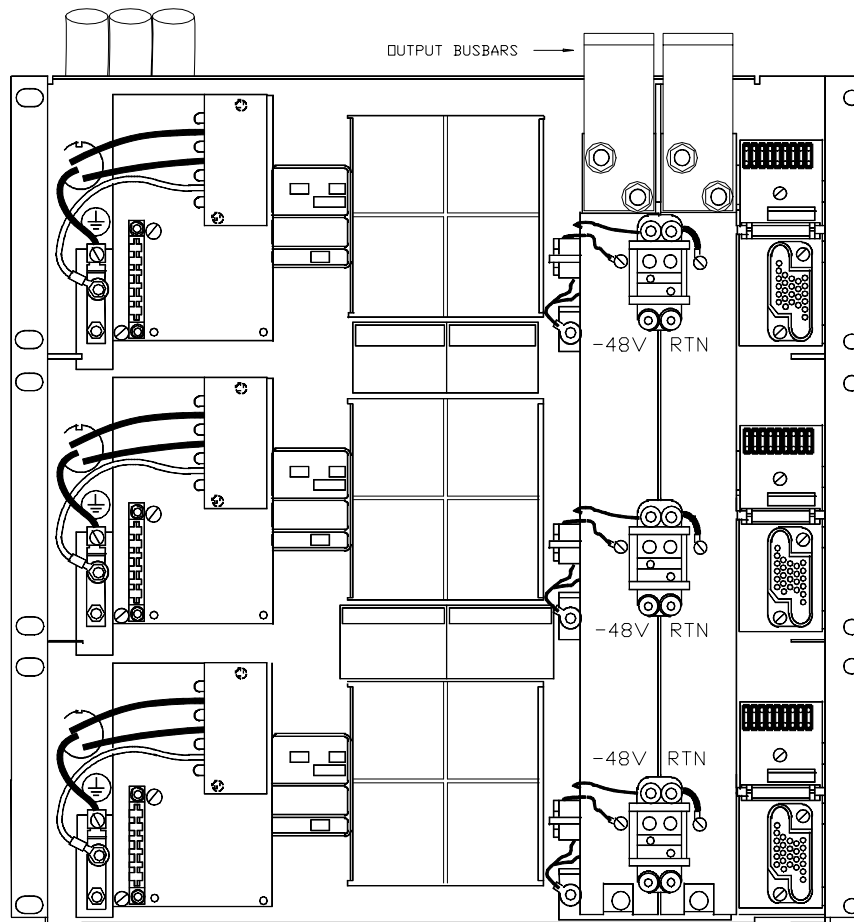
#### 3.6.1 Mechanical Specifications of the MPS300 and MPA100 Power Shelves

The mechanical specifications of the power shelves are listed in **Table 23**.

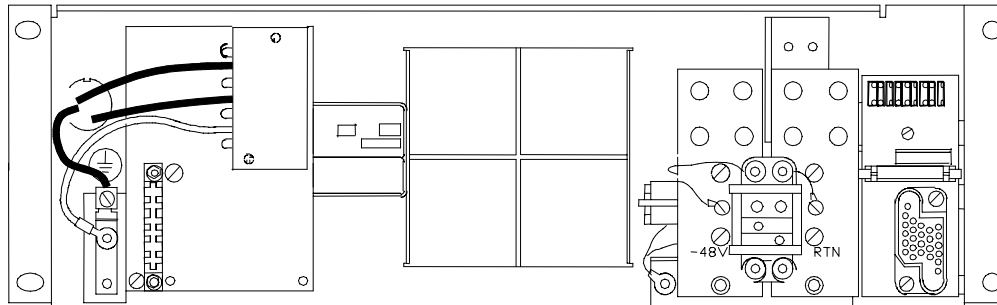
**Table 23** Mechanical specifications of the MPS300 and MPA100 power shelves

Shelf model	Figure	Height	Depth	Width	Weight
MPS300	Figure 19	533 mm (21.00 in.)	381 mm (15.00 in.)	584 mm (23.00 in.)	16.6 kg (36.5 lb)
MPA100	Figure 20	178 mm (7.00 in.)	381 mm (15.00 in.)	584 mm (23.00 in.)	5.4 kg (12 lb)

**Figure 19** Front view of the MPS300 power shelf (shown empty)



**Figure 20 Front view of the MPA100 power shelf (shown empty)**



### 3.6.2 Electrical Specifications of the Power Shelves

Each rectifier position provides interconnection points for AC input (208 to 240 V nominal), DC output (-48 V nominal) and control and alarm signals.

## 3.7 Rectifiers

The Helios system 4000/48 can be equipped with Helios Rectifiers 100/48 for single phase 208/240 V AC operation, with Helios Rectifiers 200I/48 for three phase 380/415 V AC operation, or with Helios Rectifiers 200E/48 for three phase 480 V AC operation.

### 3.7.1 Helios Rectifier 100/48

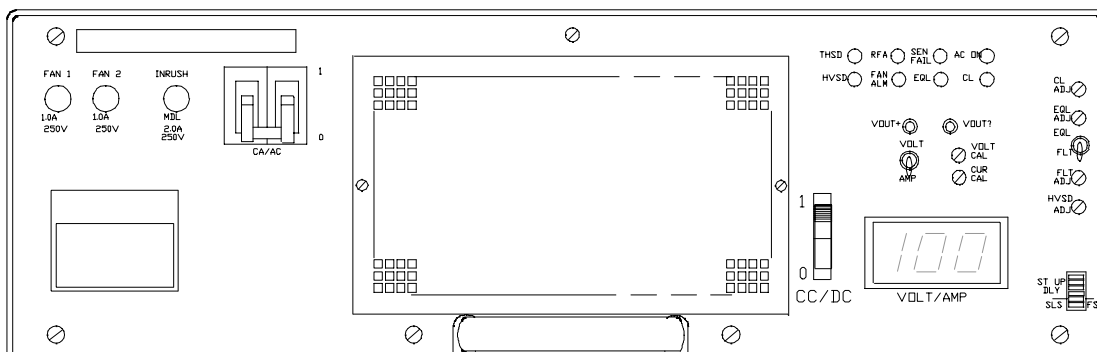
#### Mechanical specifications of the Helios Rectifier 100/48

The mechanical specifications of the Helios Rectifier 100/48 are listed in **Table 24**.

**Table 24 Mechanical specifications of the Helios Rectifier 100/48**

Figure	Height	Depth	Width	Weight
Figure 21	178 mm (7.0 in.)	305 mm (12.0 in.)	584 mm (23.0 in.)	22.2 kg (49 lb)

**Figure 21 Front view of the Helios Rectifier 100/48**



## Electrical specifications of the Helios Rectifier 100/48

The electrical specifications of the Helios Rectifier 100/48 are listed in **Table 25**.

**Table 25 Electrical specifications of the Helios Rectifier 100/48**

Parameter	Specification
<b>Input voltage:</b>	208/240 V AC, 1-phase, 47-63 Hz Input voltage range: 176 to 264 V AC
<b>Input current:</b>	31 A nominal at 208 V AC input and -56 V DC, 100 A output
<b>Recommended AC service input:</b>	50 A, two pole AC circuit breaker
<b>Output voltage:</b>	Float: -48 to -58 V DC Equalize: 0 to 4 V DC above Float Maximum: -59.5 V DC
<b>Output current:</b>	100 A per rectifier 100 A for a one position shelf 300 A for a three position shelf
<b>Input protection:</b>	A two pole / 45 A circuit breaker opens both lines.
<b>Output protection:</b>	The rectifier is protected by a 120 A circuit breaker at the output. The output current is limited to a value adjustable from 50% to 105% of the rated capacity of the rectifier. This circuit is factory set to 105 A.
<b>Output regulation:</b>	The rectifier output voltage is automatically regulated to remain within $\pm 0.5\%$ of the selected value under all load conditions and within the specified input voltage, frequency, and ambient temperature ranges. And within + 1% for any combinations of specified input, output and environmental conditions.
<b>Efficiency:</b>	Efficiency is better than 88% at a nominal input voltage of 208/240 V AC and an output load greater than 40 A.
<b>Power factor:</b>	Power factor is 0.99 at a nominal input voltage of 208 V AC and output loads greater than 40 A.
<b>Electromagnetic interference (EMI):</b>	The rectifier meets the FCC requirements for conducted and radiated EMI for Class "A" equipment.
<b>Heat dissipation:</b>	763 W (2606 Btu/hr)

### 3.7.2 Helios Rectifiers 200I/48 and 200E/48

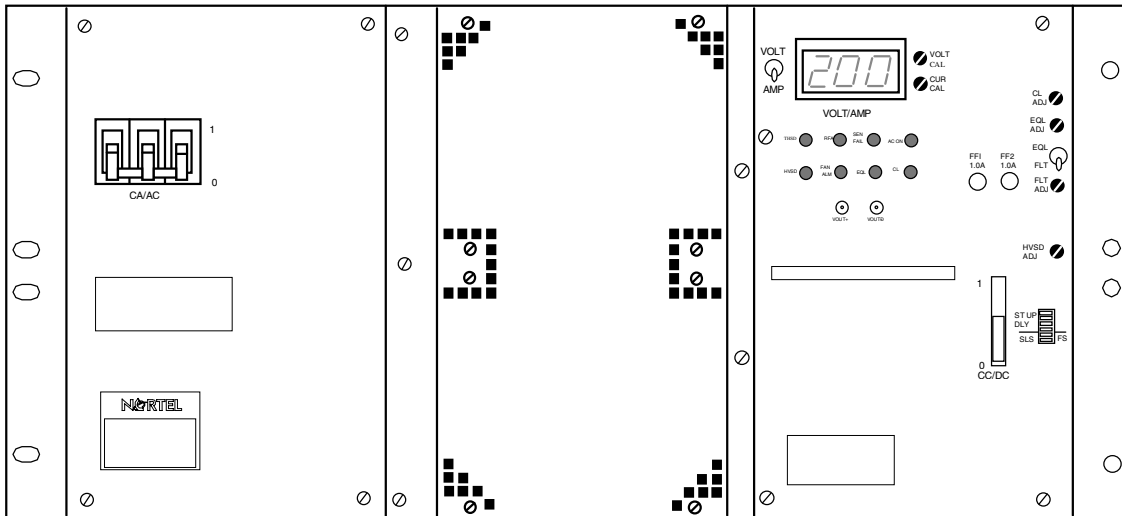
#### Mechanical specifications of the Helios Rectifiers 200I/48 and 200E/48

The mechanical specifications of the Helios Rectifier 200I/48 and 200E/48 are listed in **Table 26**.

**Table 26 Mechanical specifications of the Helios Rectifiers 200I/48 and 200E/48**

Figure	Height	Depth	Width	Weight
<b>Figure 22</b>	254 mm (10 in.)	559 mm (22 in.)	521 mm (20.5 in.)	42.3 kg (93 lb)

Figure 22 Front view of the Helios Rectifiers 200I/48 and 200E/48



### 3.7.3 Electrical Specifications of the Helios Rectifiers 200I/48 and 200E/48

The electrical specifications of the Helios Rectifiers 200I/48 and 200E/48 are listed in **Table 27**.

**Table 27 Electrical specifications of the Helios Rectifiers 200I/48 and 200E/48**

Parameter	Specification
<b>Input voltage</b>	Helios Rectifier 200I/48: 380/415 V AC, three phase, 47-63 Hz Input voltage range: 330 to 475 V AC Helios Rectifier 200E/48: 480 V AC, three phase, 47-63 Hz Input voltage range: 430 to 520 V AC
<b>Input current</b>	Helios Rectifier 200I/48: 18.3 A RMS nominal at 380 V AC input and -54 V DC, 200 A output (24 A RMS worst case) Helios Rectifier 200E/48: 15 A RMS nominal at 480 V AC input and -54 V DC, 200 A output (17 A RMS worst case)
<b>Input protection</b>	A 3 pole / 25 A circuit breaker opens all three lines.
<b>Recommended AC service input</b>	30 A, 3 pole AC circuit breaker
<b>Output voltage</b>	Float: -46 to -58 V DC Equalize: 0 to 4 V DC above Float Maximum: -60 V DC
<b>Output current</b>	200 A nominal Adjustable between 100 and 210 A
<b>Output protection</b>	The rectifier is protected by a 250 A circuit breaker at the output. The output current is limited to a value adjustable from 50% to 105% of the rated capacity of the rectifier. This circuit is factory set to 205 A.
<b>Output regulation</b>	The rectifier output voltage is automatically regulated to remain within $\pm 0.5\%$ of the selected value under all load conditions and within the specified input voltage, frequency, and ambient temperature ranges. And within + 1% for any combinations of specified input, output and environmental conditions.
<b>Efficiency</b>	Efficiency is better than 89% at nominal input voltage and an output load greater than 80 A.
<b>Power factor</b>	Power factor is better than 0.99 at nominal input voltage and an output load greater than 80 A.
<b>Electromagnetic interference (EMI)</b>	The rectifier meets the FCC requirements for conducted and radiated EMI for Class "B" equipment.
<b>Heat dissipation</b>	1,335 W (4,558 Btu/hr) at -54 V DC, 200 A output
<b>Total harmonic distortion (THD)</b>	THD is less than 5% between half load and full load at nominal input voltage

### 3.7.4 Standards

The following standards also apply to the rectifiers:

- ANSI Std. C62.41/IEEE Std. 587-1980, Class A and B lightning surge 6000 V, 3000 A, 1.2 x 50 ms impulse, 10 hits per second
- ANSI Std. C82.41 oscillatory surge 2500 V, 0.5 ms impulse, 100kHz positive/negative oscillating decay
- Bellcore TR-TSY-000947
- IEC-950, VDE EN 60950, EN 41003
- CISPR 22, Class A
- CE mark

### 3.8 Helios Monitor 3000/48 (Optional)

#### 3.8.1 Mechanical Specifications

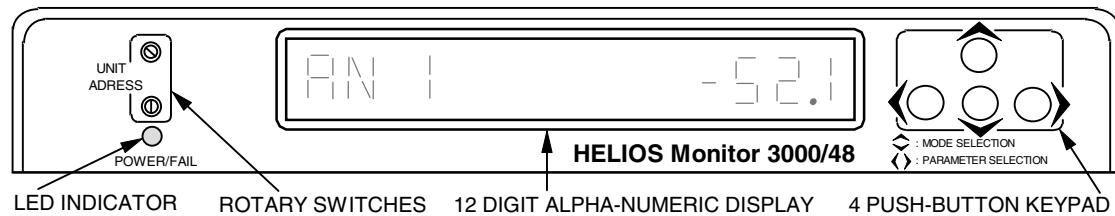
The mechanical specifications of the Helios Monitor 3000/48 are listed in **Table 28**.

**Table 28 Mechanical specifications of the Helios Monitor 3000/48**

Figure	Height	Depth	Width	Weight
Figure 23	45 mm (1.75 in.)	222 mm (8.75 in.)	280 mm (11.0 in.)	2.8 kg (6.2 lb)

The above dimensions are without the mounting brackets. The weight may vary slightly depending on the number and type of analog interface modules installed in the unit.

**Figure 23 Front view of the Helios Monitor 3000/48 (without the mounting brackets)**



#### 3.8.2 Electrical Specifications

The input voltage of the Helios Monitor 3000/48 is -48 V DC nominal, with a range of -42 V DC to -60 V DC.

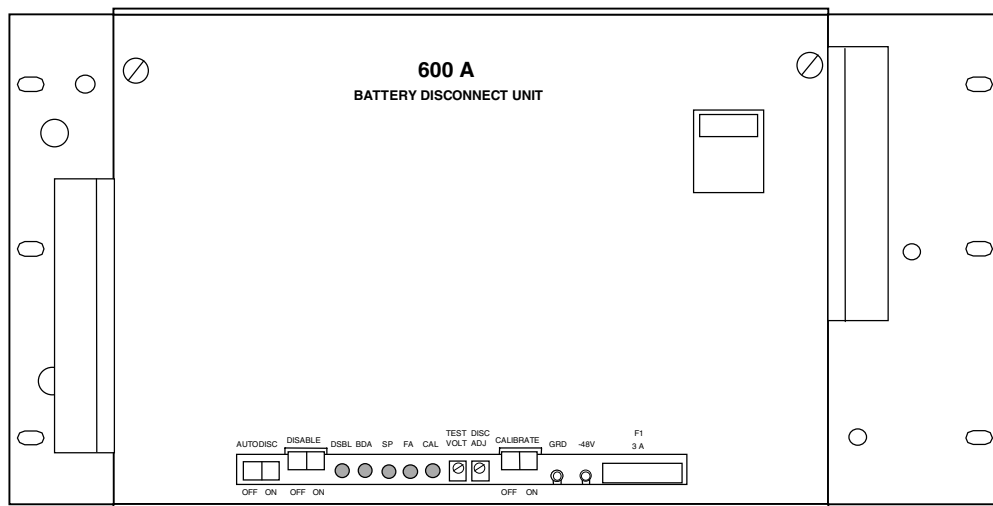
The input current drain is 400 mA. This current drain may vary slightly depending upon the number and type of analog interface modules installed in the unit.

For more detailed electrical specifications of the Helios Monitor 3000/48, refer to the appropriate user manual listed in **6.0 - Reference Documents**.

### 3.9 600 A and 1200 A Battery Disconnect Unit (Optional)

The Battery Disconnect Units are 11 inches high and provides for 500 mm (19 in.) or 600 mm (23 in.) framework mounting or wall mounting. The units are equipped with a heavy duty circuit breaker that can be used to manually or automatically disconnect a battery string. Reconnect is manual only. The breaker is mid trip and equipped with a relay trip feature.

**Figure 24 600 A Battery Disconnect Unit**

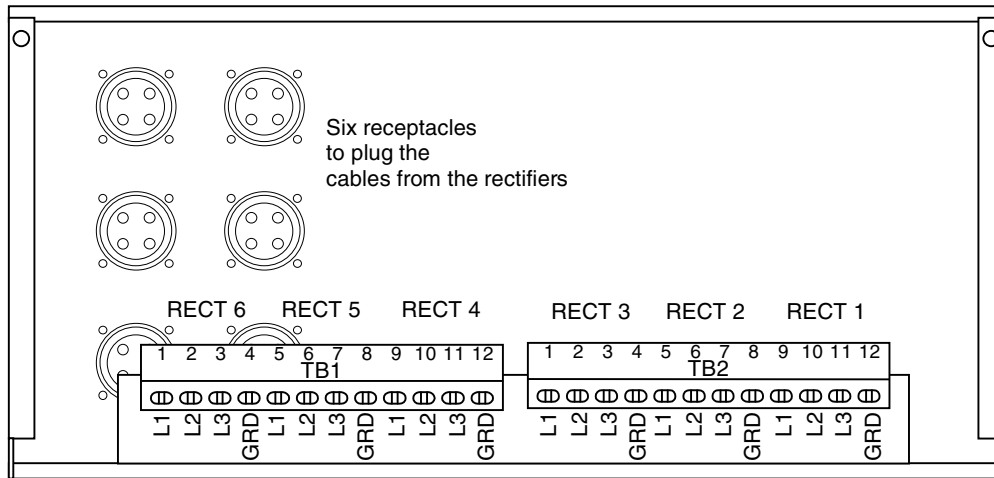


For more detailed electrical specifications of the Battery Disconnect Unit, refer to the user manual, SL-60040.

### 3.10 AC Junction Box

The AC junction box is required as an AC connection interface in rectifier cabinets where the Helios Rectifier 200E/48 is used.

**Figure 25 Front view of the AC junction box (with the front panel open)**



#### 3.10.1 Mechanical Specifications

The junction box is made of zinc plated steel and can accommodate up to six one-inch rigid or flexible conduits. The mechanical specifications are listed in **Table 29**.

**Table 29 Mechanical specifications of the AC junction box**

Figure	Height	Depth	Width
Figure 25	264 mm (10.4 in.)	284 mm (11.2 in.)	521 mm (20.5 in.)

#### 3.10.2 Electrical Specifications

The junction box is designed to accommodate six 3-phase circuits (3 wires plus ground) at a maximum voltage of 600 V AC and a capacity of 30 A per circuit.

### 3.11 Overall Power System Specifications

#### 3.11.1 Standards

The Helios DC System 4000/48 meets the following North American and European standards:

- UL-1801
- CSA 22.2 (#0.7, #225)
- TR-TSY-000406
- CE
- VDE

#### 3.11.2 Mechanical Specifications of Fully Equipped Power Cabinets

**Table 30 Mechanical specifications of fully equipped power cabinets**

Height	Depth	Width	Total weight (4000 A control and distribution cabinet)	Total weight (1200 A rectifier cabinet with six rectifiers)
2134 mm (84 in.)	600 mm (23.62 in.)	600 mm (23.62 in.)	363 kg (800 lb) approx.	440 kg (970 lb) approx.



### 3.11.3 Electrical Specifications

Refer to the individual component's specifications.

#### Electromagnetic compliance (EMC)

The equipment contained in the power system complies with the specifications of FCC, Part 15, Subpart B for class A equipment, CSA 108.8 for class A and CISPR 22 for class A.

#### Electrostatic discharge (ESD) immunity

No equipment damage or malfunctions shall occur when electrostatic discharge voltages of severity level 2 and 4, as specified by IEC-801-2, are applied to exposed parts of the power system.

### 3.11.4 Environmental Specifications

#### Operating

- Temperature:** 0° to +50°C (32° to 122°F)  
**Humidity:** 0 to 95% non-condensing  
**Altitude:** Sea level to 2134 m (7000 ft)

#### Transportation



#### NOTE

*Do NOT ship with the rectifiers installed in the rectifier cabinet(s).*

During transportation the equipment may be subjected to the following conditions without damage:

- Temperature:** -50° to +75°C (-58° to +167°F)  
**Humidity:** 0 to 95% (non condensing) 4kPa max. WVP for 10 days  
**Vibration:** TR-NWT-000063 section 5.4.4 Transportation Vibration (packaged equipment)  
**Shock:** TR-NWT-000063, Section 5.4.1 Handling Drop Tests, and Section 5.4.3 Installation Shop Tests

#### Storage

- Temperature:** -50° to +75°C (-58° to +167°F)  
**Humidity:** 0 to 95% (non condensing) 4kPa max. WVP for 10 days

#### Heat dissipation

A Helios DC System 4000/48 rectifier cabinet equipped with six Helios Rectifier 200I/48 or 200E/48 will dissipate a maximum of 8,010 watts or 27,350 Btu/hr.

### 3.11.5 Floor and Point Loading

The floor loading is based on a footprint of 600 mm x 600 mm (23.6 in. x 23.6 in.) plus a 30-inch aisle width (15 inches front and rear).

The point loading is based on distributing the cabinet weight over four shims, each with an assumed area of 25.8 cm<sup>2</sup> (4 in.<sup>2</sup>).

See **Figure 1** for a typical system configuration for floor and point loading calculations.

**Table 31 Floor and point loading**

Cabinet type	Floor loading	Point loading
Control and distribution cabinet	41.3 kN/sq m (90.9 lb/sq ft)	34.5 N/sq cm (50 lb/sq in.)
Auxiliary distribution cabinet	32.3 kN/sq m (71 lb/sq ft)	26.9 N/sq cm (39 lb/sq in.)
Rectifier cabinet	50.1 kN/sq m (110.2 lb/sq ft)	41.8 N/sq cm (60.6 lb/sq in.)

## 4.0 OPERATION

### 4.1 General

This chapter describes the control, adjustment and operational features of the Helios DC System 4000/48.

### 4.2 Conventional Controller

The Conventional Controller monitors the operation of the entire power plant. It monitors all the alarms, and it controls and monitors the rectifiers.

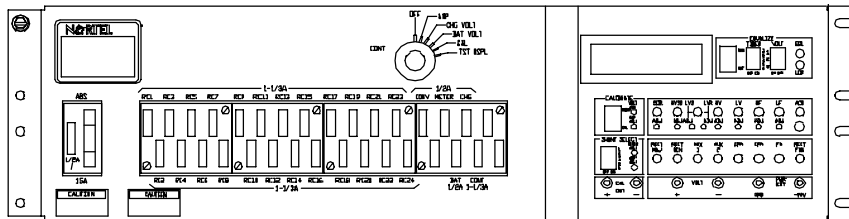
Provision is made on the back of the Conventional Controller to extend any occurring alarm to the alarm center through the facilities provided in the powered equipment.

All of the control switches, potentiometers, operational and alarm visual indications are located at the front of the Conventional Controller.

#### 4.2.1 Front Panel

The front panel of the Conventional Controller is provided with the control, alarm and operational features shown in **Figure 26** and described in the following subsections.

**Figure 26 Front view of the Conventional Controller**



#### Visual indicators

A 4.5 digit red LED readout to display the system current and voltage, and 18 LEDs to display the alarm conditions as described in **Table 32**. All alarm conditions are also displayed by a red incandescent cabinet alarm lamp.

**Table 32 Visual indicators**

Designation	Description	Color
RECT FAN	Rectifier Fan Failure	yellow
EQL	Equalize On	yellow
FA	Fuse Failure Alarm (Internal to the Controller)	red
DFA	Discharge Fuse Alarm	red
CFA (not used)	Charge Fuse Alarm	red
RFA MIN	Rectifier Failure Alarm Minor	yellow
RFA MAJ	Rectifier Failure Alarm Major	red
ACO	Alarm cut-off	red
HVSD	High Voltage Shutdown Alarm	red
HV	High Voltage Alarm	red
LV	Low Voltage Alarm	red
HF	High Float Alarm	yellow
LF	Low Float Alarm	yellow
LVD	Low Voltage Disconnect	red
BOD	Battery On Discharge	red
LOP	Loss of Phase	red
AUX 1 (BDA)	Auxiliary Major	red
AUX 2	Auxiliary Minor	yellow

**Table 33 Transmitted alarms**

Alarm	Description
RECT FAN	(1 - Form C contacts)
RFA MIN	(1 - Form C contacts)
RFA MAJ	(1 - Form C contacts)
H/L FLOAT	(2 - Form C contacts)
EQL ALM	(1 - Form C contacts)
H/L VOLT	(2 - Form C contacts)
FA	(1 - Form C contacts)
CHG FUSE	(1 - Form C contacts)
DISCH FUSE	(1 - Form C contacts)
LVD	(1 - Form C contacts)
LOSS OF AC VOLT	(1 - Form C contacts)
AUX 1 ALM	(2 - Form C contacts)
AUX 2 ALM	(2 - Form C contacts)
HVSD	(1 - Form C contacts)
BOD	(1 - Form C contacts)
MIN VIS (note 2)	(2 - Form C contacts)
MAJ VIS (note 2)	(2 - Form C contacts)
MIN AUD	(2 - Form C contacts)
MAJ AUD	(2 - Form C contacts)

**NOTE**

*Form C contacts are rated at 0.5 A, 60 V AC.*

*MINOR VIS (2) and MAJ VIS (2) are used for the cabinet alarm lamp.*

**Potentiometers**

Twelve potentiometers for the adjustment of alarm and control functions as described in **Table 34**.

**Table 34 Potentiometers**

Designation	Description
HVSD	High Voltage Shutdown
HV	High Voltage Alarm
LV	Low Voltage Alarm
HF	High Float Alarm
LF	Low Float Alarm
LVD	Low Voltage Disconnect
BOD	Battery On Discharge
VOLT ADJ	Plant Voltage Adjustment
REF CAL	Reference Calibration
METER ADJ	Meter Adjustment
AMP ADJ	Ampere Adjustment
LVR	Low Voltage Reconnect

## Switches

Four switches for the control of functions as described in **Table 35**.

**Table 35 Switches**

Designation	Description
EQUALIZE MAN/AUTO	Used to activate or deactivate the equalize function.
ACO	Used to cancel the audible alarm signal.
CALIBRATE NORM/CAL	Used to activate or deactivate the calibration function.
CONT rotary switch	Six position switch: OFF, AMP, CHG VOLT, BAT VOLT, CAL, TST DISPL

## DIP switches

Three DIP switch modules for the setting of functions as described in **Table 36** and as shown in **Figure 27** and **Figure 28**.

**Table 36 DIP switch modules**

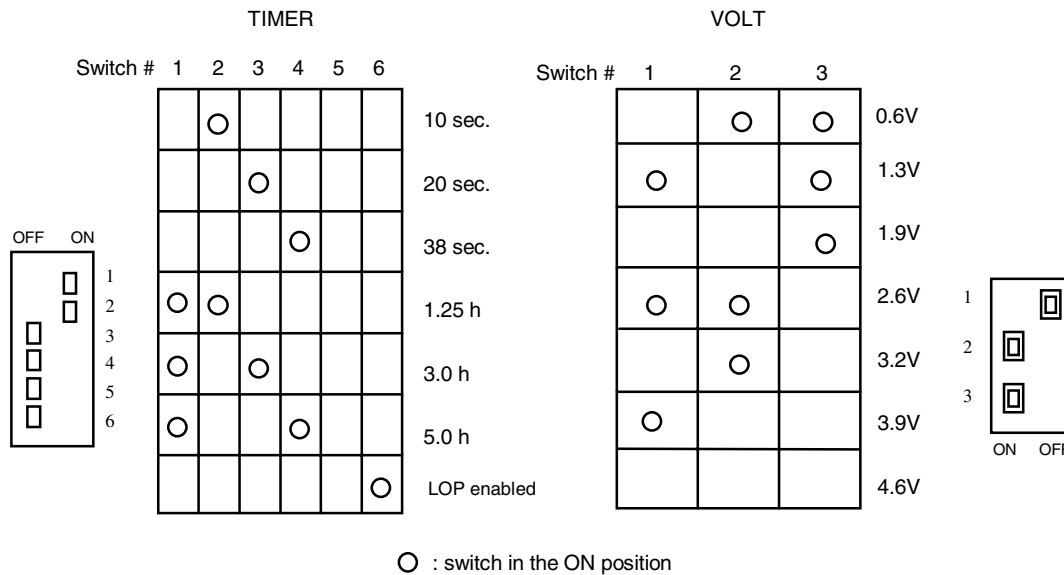
Designation	Description
SHUNT SELECT	To select the shunt size
TIMER	To select the duration of the equalize
VOLT	To select the equalize voltage

**Figure 27 Shunt range selection settings**

S1						RANGE AMPS MIN-MAX
1	2	3	4	5	6	
<input type="radio"/>					<input type="radio"/>	55 to 100
	<input type="radio"/>				<input type="radio"/>	100 to 170
		<input type="radio"/>			<input type="radio"/>	170 to 340
			<input type="radio"/>		<input type="radio"/>	340 to 500
<input type="radio"/>						500 to 1000
	<input type="radio"/>					1000 to 1700
		<input type="radio"/>				1700 to 3400
			<input type="radio"/>			3400 to 7000
				<input type="radio"/>		7000 to 14000

= SWITCH IS ON

**Figure 28 Equalize voltage and duration settings**



**Fuses**

Thirty-four fuses for circuit protection as described in **Table 37**. Except for the ABS fuse, which is small tube type (9/32" dia x 1-1/4" long), all fuses are of the QFF type.

**Table 37 Fuse**

Designation	Capacity	Description
ABS	15 A	-48 V supply for the office alarm circuit(s)
ABS ALM	1/2 A	Alarm fuse for the above ABS fuse
RC1 to RC24	1-1/3 A	-48 V sense supply for the rectifiers of the system
CONV	1/2 A	Protection for the internal converter in the controller
METER	1/2 A	Protection for the meter and selector panel if so equipped
CHG	1/2 A	Protection for internal circuitry of the controller when the CONT rotary switch is in the CHG VOLT position
Spare 1 and 2	0 to 5 A	For external loads as required (ex.: Helios Monitor)
BAT	1/2 A	Protection for internal circuitry of the controller when the CONT rotary switch is in the BAT VOLT position
CONT	1-1/3 A	Protection for the internal circuitry of the controller
Plus one unused position		

**Test points**

Three sets of test points for applications as described in **Table 38**.

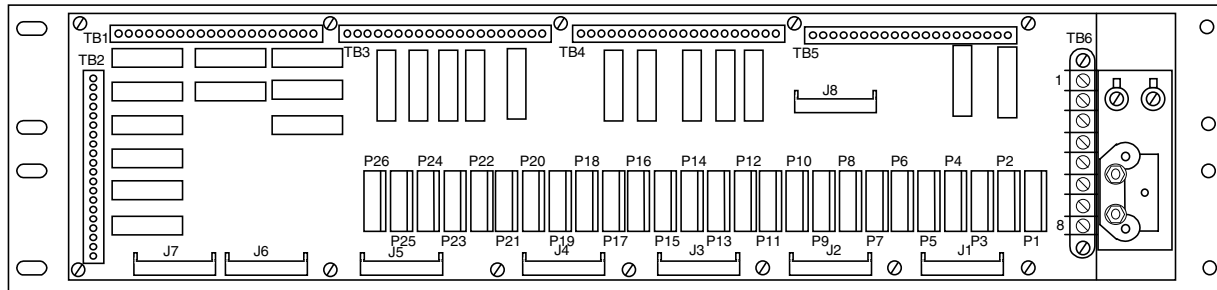
**Table 38 Test points**

Designation	Description
CAL OUT + and -	To connect an external meter when calibrating the LED readout for current readings
VOLT + and -	To connect an external meter when adjusting the BOD, LF, LV, HF, HV, HVSD, LVD and LVR thresholds
PWR EXT + and -	The connect an external power supply when adjusting the LVR threshold

## 4.2.2 Rear Panel

The rear panel of the Conventional Controller is provided with the connection interface features shown in **Figure 30** and described in the following subsections.

**Figure 29 Terminal blocks and connectors layout at the rear of the Conventional Controller**



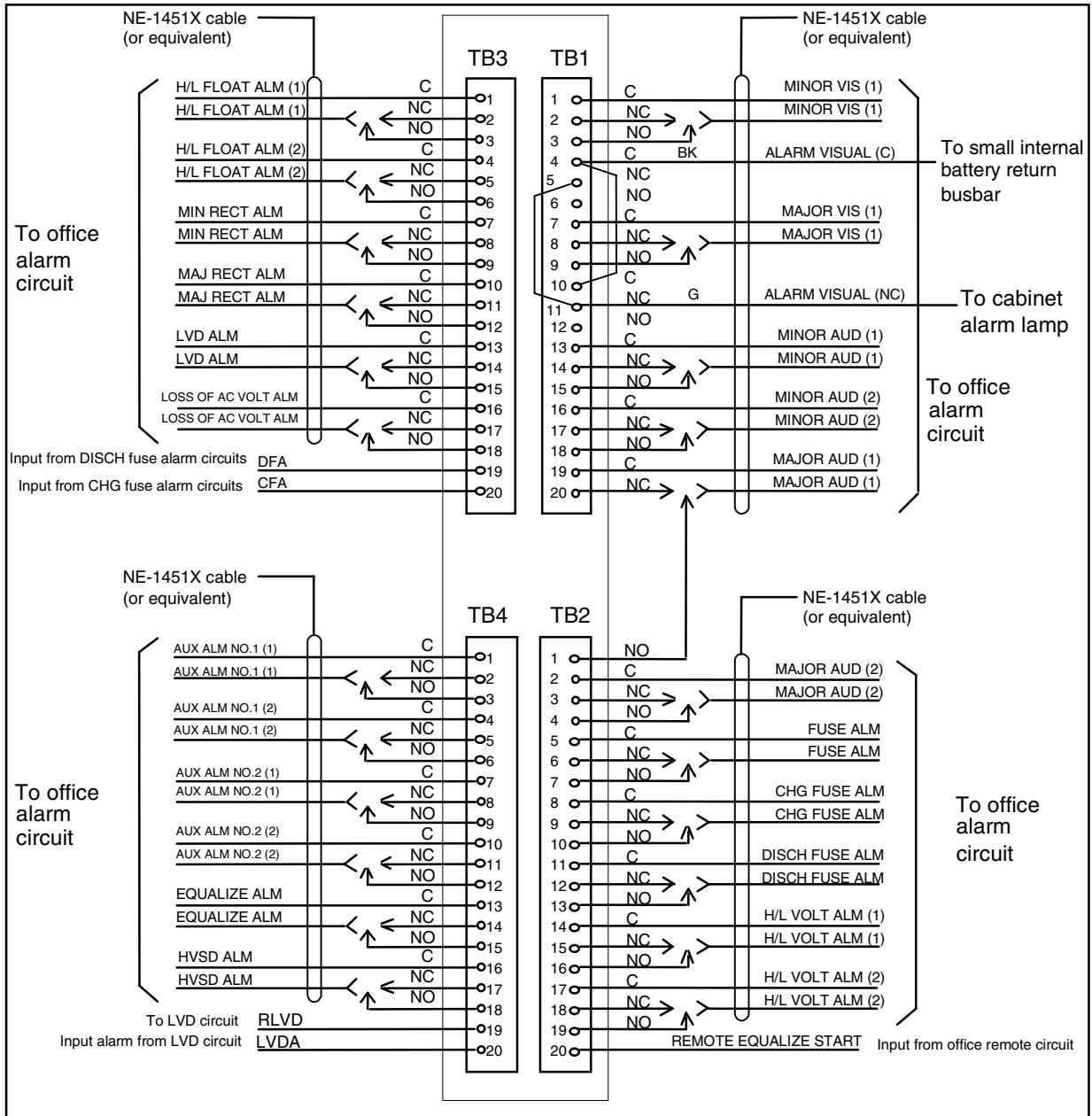
### Terminal blocks

Six terminal blocks to interface with external wiring as follows:

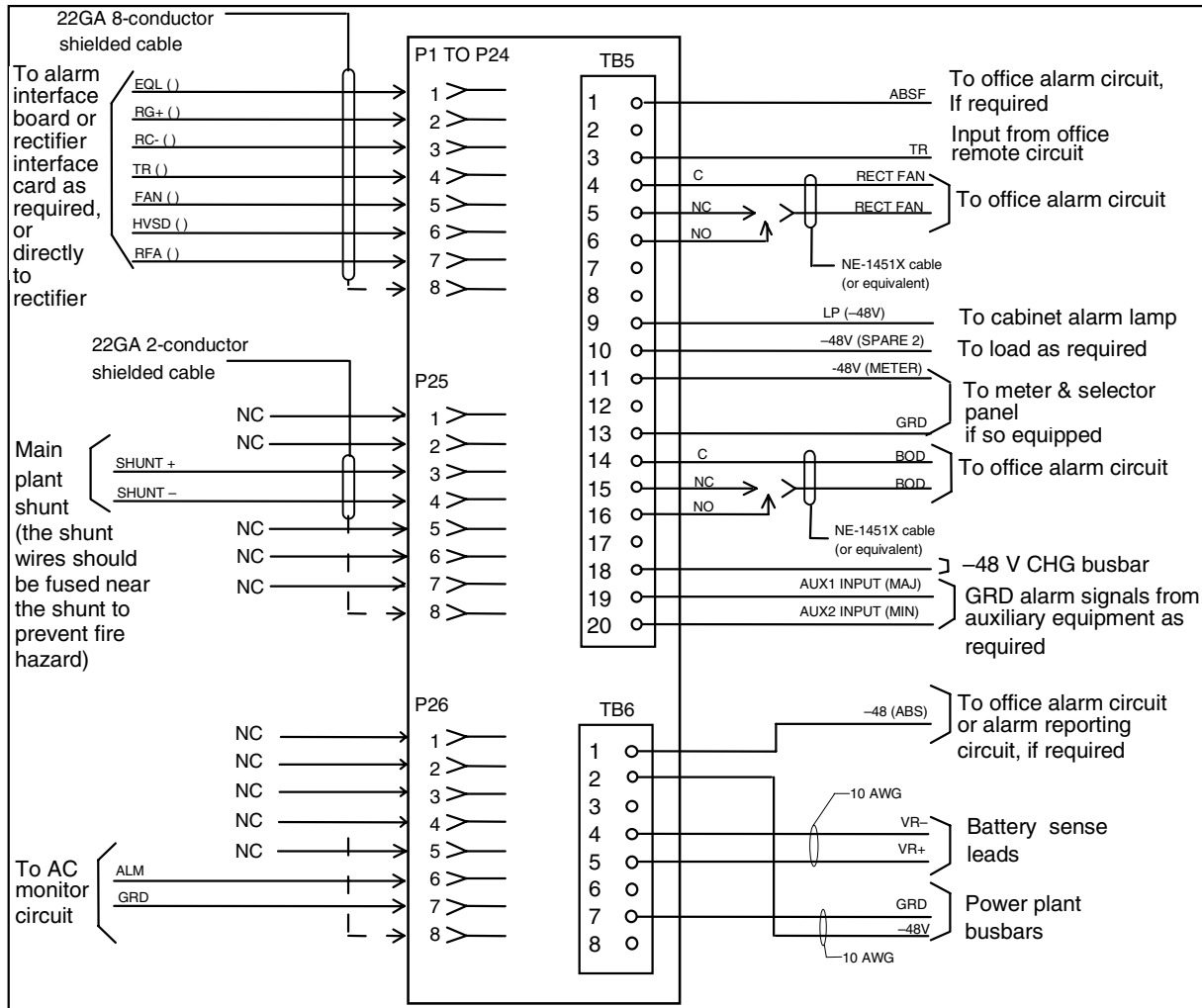
- TB1: various alarm outputs to the office alarm circuits and the cabinet alarm lamp
- TB2: various alarm outputs to the office alarm circuits, and remote equalize signal input
- TB3: various alarm outputs to the office alarm circuits, and charge and discharge fuse alarm inputs
- TB4: various alarm outputs to the office alarm circuits, and LVD control and alarm
- TB5: various alarm outputs to the office alarm circuits, remote TR signal input, -48 V supply to cabinet alarm lamp and various small loads, and AUX 1 and AUX 2 alarms inputs
- TB6: -48 V supply to office alarm circuits if required, VR+ and VR- inputs, and -48 V and ground inputs

Refer to **Figure 30** and **Figure 31** for the pin assignment of terminal blocks TB1 to TB6.

**Figure 30 Wiring diagram and pin assignment of terminal blocks TB1 to TB4**



**Figure 31 Wiring diagram and pin assignment of terminal blocks TB5 and TB6, and connectors P1 to P26**



### Connectors

Twenty-six connectors to interface with external equipment as follows:

- P1 to P24: signaling between the controller and the rectifiers
- P25: interface with the main power system shunt
- P26: interface with an AC monitoring device

Refer to **Figure 31** for the pin assignment of connectors P1 to P26.

Eight connectors (J1 to J8) for the interface between the two circuit boards of the controller (for factory use only).

### 4.3 MPS300 and MPA100 Power Shelves

The MPS300 power shelf provides the interconnecting points for all the AC, DC and control cabling and wiring for three Helios Rectifier 100/48. The MPA100 power shelf does the same for one Helios Rectifier 100/48.

Refer to the appropriate rectifier user manual listed in **6.0 - Reference Documents** for detailed operation information on the MPS300 and MPA100 power shelves.



---

## 4.4 Rectifiers

The rectifiers provide isolated, filtered and regulated DC power, from either a single-phase AC source (Helios Rectifier 100/48) or a three-phase AC source (Helios Rectifier 200I/48 or 200E/48), for charging a positive grounded battery.

The nominal output is adjustable over the range of -46 to -59.5 V to float a 23 or 24 cell battery string.

The rectifiers are equipped with AC input and DC output circuit breakers, a digital ammeter, potentiometers for the adjustment of thresholds, and LED indicators for alarm indications.

The rectifiers use high frequency switching technology and forced air-cooling.

Refer to the appropriate rectifier user manual listed in **6.0 - Reference Documents** for detailed operation information on the Helios Rectifier 100/48, the Helios Rectifier 200I/48, or the Helios Rectifier 200E/48.

## 4.5 AC Junction Box



### **WARNING PREVENTING ELECTRICAL SHOCKS**

**WHEN OPENING THE DOOR OR WIRING THE AC INPUT OF THE RECTIFIERS INSIDE THE JUNCTION BOX, ENSURE THAT THE ASSOCIATED AC BREAKERS, LOCATED IN THE AC SERVICE PANEL, ARE IN THE OFF POSITION AND THAT A WARNING TAG CLEARLY INDICATES THAT THESE BREAKERS ARE TO REMAIN OFF UNTIL THE AC WIRING HAS BEEN COMPLETED. DO NOT INSERT FUSES, OR OPERATE CIRCUIT BREAKER OR SWITCHES TO ON UNTIL THE WIRING IS COMPLETED AND YOU ARE INSTRUCTED TO DO SO.**

The AC junction box is part of the rectifier cabinet used for the Helios Rectifier 200E/48. It is located at the top of the cabinet for top fed systems, or at the bottom of the cabinet for bottom fed systems.

The AC junction box provides AC connection interface for up to six rectifiers and facilitates the addition and/or replacement of rectifiers in a working system. The AC supply from the AC service panel is hard wired inside the box at the time of the initial installation. Detailed cabling and connecting guidelines for the AC junction box can be found in **5.0 - Maintenance**.

The rectifiers are provided with a factory-installed AC cord equipped with a male connector. This male connector is plugged into a matching female receptacle at the rear of the AC junction box. For the complete procedures for adding or replacing a rectifier, refer to **5.0 - Maintenance**. Note that caps are provided to protect the unused female receptacles.

## 4.6 Distribution Panels

All distribution panels provide local alarm indication on the panel itself, and alarm extension to the controller for additional indication on the controller and the cabinet and further extension to remote alarm facilities.

## 4.7 Terminating Assemblies (Optional)

Terminating assemblies are optional devices used to facilitate the connecting of loads to distribution fuses or circuit breakers larger than 199 A. These assemblies can be used in top fed systems only (they cannot be used on bottom fed systems). Each terminating assembly provides connection facilities for up to six loads without having to route the cables inside the cabinet during installation.

Two terminating assemblies can be used on an auxiliary distribution cabinet, while only one terminating assembly can be used on a main control and distribution cabinet.

---

## 4.8 Helios Monitor 3000/48 (Optional)

The Helios Monitor 3000/48 is a microprocessor-based unit used to monitor and record power systems operational data. The recorded data is accessible locally by means of the front panel or the RS-232 port, or remotely through the modem link.

If an Helios Monitor 3000/48 was supplied with your system, refer to the Monitor 3000 user manual, SL-60015, for detailed operational characteristics.

## 4.9 600 A and 1200 A Battery Disconnect Units (Optional)

The 600 A and 1200 A Battery Disconnect Units (BDU) are equipped with a circuit breaker that provides for automatic or manual disconnect, but only manual reconnect. The automatic disconnect is intended to serve the low voltage disconnect function to prevent batteries from deep discharge that could damage them. The circuit breaker has industrial grade contacts to connect and disconnect large currents, and it is provided with a relay trip feature.

If battery disconnect unit(s) were supplied with your system, refer to the user manual, SL-60040, for the detailed operational characteristics of the battery disconnect unit.

---

## 5.0 MAINTENANCE

---

### 5.1 General

The following is a list of general preventive maintenance procedures which should be performed periodically as required according to the environmental conditions and customer maintenance policy to ensure trouble free operation of the Helios DC System 4000/48:

- clean all ventilation openings
- if these are used, clean or replace the air filters on the rectifiers
- tighten all electrical connections
- check for hot fuses or breakers (loose, undersized or overloaded)
- verify alarms and alarm thresholds
- verify calibration settings
- verify rectifier settings

The voltage and alarm settings of the controller and rectifiers are based on the type of batteries used with the power system. The recommended settings for various types of batteries can be found in SL-60026, Voltage Level Limits for Power Plants, Rectifiers and Controllers. If unlisted models of batteries are used, it may be necessary to follow specific customer or manufacturer requirements.

The following is list of the tools and test equipment required to adjust the equipment in the Helios DC System 4000/48:

- a potentiometer screwdriver, Bourns No. 60 or equivalent
- a digital voltmeter, Fluke 8050A or equivalent
- a dummy load, 5 kVA

#### 5.1.1 Helios Monitor 3000/48

If the power system is equipped with a Helios Monitor 3000/48, refer to the user manual, SL-60015, for maintenance and troubleshooting information.

#### 5.1.2 Controller and Rectifiers

The controller and the rectifiers need little maintenance. The following should be checked periodically in order to ensure trouble free operation.



#### **WARNING**

#### **PREVENTING DAMAGE TO THE EQUIPMENT**

**DO NOT ATTEMPT ANY OTHER REPAIR THAN THOSE LISTED BELOW. IF ANY PROBLEM PERSISTS, CONTACT LIEBERT GLOBAL SERVICES AT 1-800-LIEBERT.**

#### **Cleaning**

Clean the front panels and the LED display screens with a soft cloth and isopropyl alcohol.

#### **Calibration**

Verify the calibration of the alarm and control thresholds at least once a year. Follow the calibration instructions detailed in the appropriate user manual.

#### **Storage**

The rectifiers contain aluminum electrolytic capacitors. For this reason, they shall be either kept in operation, or energized once a year for at least two hours in order to maintain the electrolytic capacitors in good condition.

---

### **Air filter replacement**

In dusty environments, the use of an air filter is strongly recommended. When used, it should be replaced at least once a year. Do not install a wet filter on a rectifier. To remove the filter, simply unscrew it. Install the new one by reversing the operation. Contact your local Liebert representative for ordering information on air filters.

### **Fan unit replacement**

Visually inspect the airflow intake for any obstruction by foreign objects or excessive dust and dirt build-up. Open both AC and DC breakers. If the rectifier is a Helios Rectifier 100/48, remove it from the power shelf. Inspect the air outlet for obstruction by foreign objects. Visually inspect the air outlet of the power shelf (Helios Rectifier 100/48) or the cabinet (Helios Rectifiers 200I/48 and 200E/48). The fan unit is field replaceable. Contact your local Liebert representative for ordering information on replacement fans. To install a new fan unit, refer to the appropriate procedure and associated figures in the maintenance chapter of the applicable rectifier user manual listed in **6.0 - Reference Documents**. If a problem is detected inside the rectifier, contact **Liebert Global Services** at **1-800-LIEBERT**. Do not attempt to open the unit for on-site servicing.

## 5.2 Troubleshooting

**Table 39** provides a list of the problems that may occur on the Helios DC System 4000/48, along with their possible causes. Blown fuses and tripped circuit breakers should always be investigated before utilizing **Table 39**.

**Table 39** Fault diagnosis

Fault symptom	Possible causes
<b>No DC output current</b>	Open AC circuit breaker Open DC circuit breaker Faulty connection between the power shelf and the rectifier (Helios Rectifier 100/48) Faulty connection between the rectifier and the power plant Sense leads opened
<b>Incorrect indication of the DC output current</b>	Incorrect meter calibration Loose shunt leads connection
<b>Low float voltage</b>	Faulty rectifier(s) Shorted battery cell(s) Prolonged power failure Incorrect float voltage adjustment Sense leads opened
<b>Low recharge voltage</b>	Incorrect float voltage adjustment Discharge load greater than the rectifier's capacity (batteries are recharging or the system is in manual bypass) Sense leads opened
<b>High float or recharge voltage</b>	Faulty rectifier(s) Incorrect Float/Equalize adjustment
<b>Failure to generate alarms during alarm conditions</b>	Incorrect connections between the controller and the rectifiers and distribution panels
<b>Failure to generate cabinet alarm during minor or major alarm conditions</b>	Faulty LP fuse on the controller (F31) Faulty cabinet alarm lamp Faulty or loose connection
<b>Failure to generate RFA alarm under appropriate conditions</b>	Faulty rectifier Faulty wiring Faulty RFA LED
<b>Failure to generate FA alarm</b>	Faulty wiring Faulty fuse Faulty FA LED Loose connection
<b>HV lamp lit</b>	High discharge voltage condition Incorrect HV level adjustment
<b>LV lamp lit</b>	Low discharge voltage condition Incorrect LV level adjustment
<b>HF lamp lit</b>	High discharge voltage condition Incorrect HF level adjustment
<b>LF lamp lit</b>	Low discharge voltage condition Incorrect LF level adjustment
<b>FA lamp lit</b>	Blown fuse or extended FA alarm
<b>CFA lamp lit</b>	Blown charge fuse
<b>DFA lamp lit</b>	Blown distribution fuse
<b>RECT MIN lamp lit</b>	One rectifier has failed
<b>RECT MAJ lamp lit</b>	Two or more rectifiers have failed
<b>RECT FAN lamp lit</b>	Defective rectifier fan(s)

**Table 39 Fault diagnosis**

<b>Fault symptom</b>	<b>Possible causes</b>
<b>LOP lamp lit</b>	Loss of one or more phases in the AC supply
<b>HVSD lamp lit</b>	High voltage shutdown condition initiated by the controller
<b>LVD lamp lit</b>	Low voltage disconnect condition initiated by the controller
<b>AUX 1 lamp lit</b>	User defined alarm condition When a Battery Disconnect Unit is present, this lamp will indicate that a battery disconnect alarm is ongoing.
<b>AUX 2 lamp lit</b>	User defined alarm condition
<b>BOD lamp lit</b>	Low discharge voltage condition Incorrect BOD level adjustment
<b>ACO lamp lit</b>	ACO switch has been operated during an alarm condition which is still ongoing
<b>EQL lamp lit</b>	The equalize function has been activated
<b>Rectifiers are not sharing the load</b>	Incorrect float or equalize adjustment on one of the rectifiers Sense leads opened on one rectifier Share mode incorrectly set
<b>Meter display is OFF</b>	Open meter fuse Meter and display failure Meter and display rotary switch in the OFF position

### 5.3 Addition / Replacement Procedures

#### 5.3.1 Addition or Replacement of a Rectifier



#### **WARNING**

**PRECAUTIONS SHALL BE TAKEN TO AVOID SERVICE INTERRUPTIONS**

**WHEN INSTALLING A RECTIFIER, THE FLOAT AND EQUALIZE VOLTAGES MUST BE SET ACCORDING TO THE TYPE OF BATTERIES USED WITH THE SYSTEM. FAILURE TO SET THESE VOLTAGES PROPERLY MAY RESULT IN BATTERY UNDERCHARGING OR OVERCHARGING AND/OR BATTERY DAMAGE.**



#### **WARNING**

**PROTECTING PERSONNEL AGAINST ELECTRICAL SHOCKS**

**INPUT VOLTAGES TO THE RECTIFIERS ARE AT A DANGEROUS LEVEL. ENSURE THAT THE CIRCUIT BREAKERS ARE LOCKED IN THE OFF POSITION AT THE AC SERVICE PANEL BEFORE ATTEMPTING TO WORK ON THE RECTIFIERS. DANGEROUS VOLTAGES MAY STILL BE PRESENT AT THE TERMINALS EVEN IF THE RECTIFIERS ARE OFF. USE A VOLTMETER TO VERIFY FOR THE PRESENCE OF SUCH VOLTAGES. DO NOT SWITCH CIRCUIT BREAKERS TO ON UNTIL INSTRUCTED TO DO SO IN THE APPROPRIATE PROCEDURE.**

Add a rectifier as described in the following procedure for a Helios Rectifier 100/48 or as in the **Adding a Helios Rectifier 200I/48 or 200E/48** procedure, whichever is applicable.

---

## Adding a Helios Rectifier 100/48

1. Remove the rectifier blank panel and store it for future use.  
**Note:** Should a rectifier be removed at any time, re-install the blank panel to meet the regulatory requirements.
2. Verify that the AC, DC and signalling cabling for the rectifier shelf has been previously installed and verified.
3. Ensure that the AC and DC circuit breakers on the front panel of the rectifier are in the OFF position.
4. Carefully slide the rectifier into position, making sure that it is fully inserted.
5. Install the left and right side clamping brackets supplied with the rectifier to secure it into position.
6. Operate the AC circuit breaker of the new rectifier to the "ON" position.
7. With the DC breaker in the "OFF" position, adjust the float, equalize and high voltage shutdown voltage levels as required. Refer to the appropriate rectifier user manual (see **6.0 - Reference Documents**).
8. Install the corresponding sense fuse (RC) on the front of the controller.
9. Ensure that the FLS/FS switch on the rectifier is set to the same position as that of the other rectifiers in the power system.
10. Operate the DC circuit breaker of the rectifier to the "ON" position.
11. Verify that the rectifier is sharing the load by observing its ammeter. It should display approximately the same value as the ammeters on the other rectifiers. If not, adjust its float and equalize voltage levels as described in the appropriate rectifier user manual (see **6.0 - Reference Documents**).

## Adding a Helios Rectifier 200I/48 or 200E/48

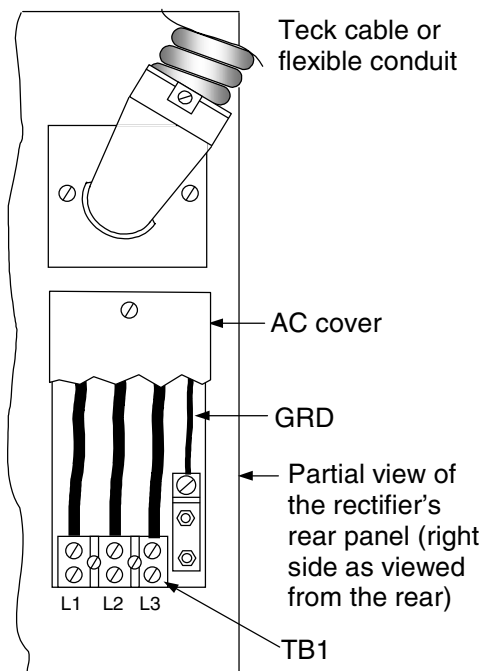
1. Ensure that the AC and DC circuit breakers on the front panel of the rectifier are in the OFF position.
2. Use a manual lift (or at least two people) to lift the rectifier to its position, rest it on the angle guides, and slide it into the cabinet.
3. Align the mounting holes of the rectifier with those of the cabinet uprights and secure the rectifier in place using the eight mounting screws provided.  
**Note:** A star washer must be used on one of the mounting screws.
4. Bring the connectorized AC cord up (top fed) or down (bottom fed) the cabinet and secure as required.
5. Install the required circuit breaker at the AC service panel.
6. Ensure that the circuit breaker installed per **Step 5** is locked in the open (OFF) position.
7. Determine the length of cable (or individual wires in conduit) required to bring the AC supply from the AC service panel to the rectifier cabinet.
8. Cut the cable (or wires) to the required lengths then run and secure between the AC service panel and the rectifier cabinet.
9. Strip the sheathing and insulation material away from the ends of the wires to expose the AC leads
10. For a Helios Rectifier 200E/48 without an AC cord, remove the AC protective cover at the rear of the rectifier and connect the AC leads inside the rectifier as shown in **Figure 32**, then reinstall the AC protective cover.

For a Helios Rectifier 200E/48 or a Helios Rectifier 200I/48 equipped with an AC cord, first connect the associated female receptacle supplied with the rectifier to the cable (or wires) incoming from the AC service panel (refer to **Figure 33**). Then, plug the male connector at the end of the rectifier AC cord into the female receptacle.

For a Helios Rectifier 200E/48 equipped with an AC cord, feed the cables through the appropriate strain relief connector at the top (top fed) or bottom (bottom fed) of the rectifier AC junction box inside the cabinet (refer to **Figure 34**). Use a flat blade screwdriver to tighten the strain relief connector, then connect the wires to the appropriate terminals inside the junction box as shown in **Figure 34**. Use plastic cable ties to secure the wires at the tie down points (one for each rectifier position) inside the junction box. Plug the male connector at the

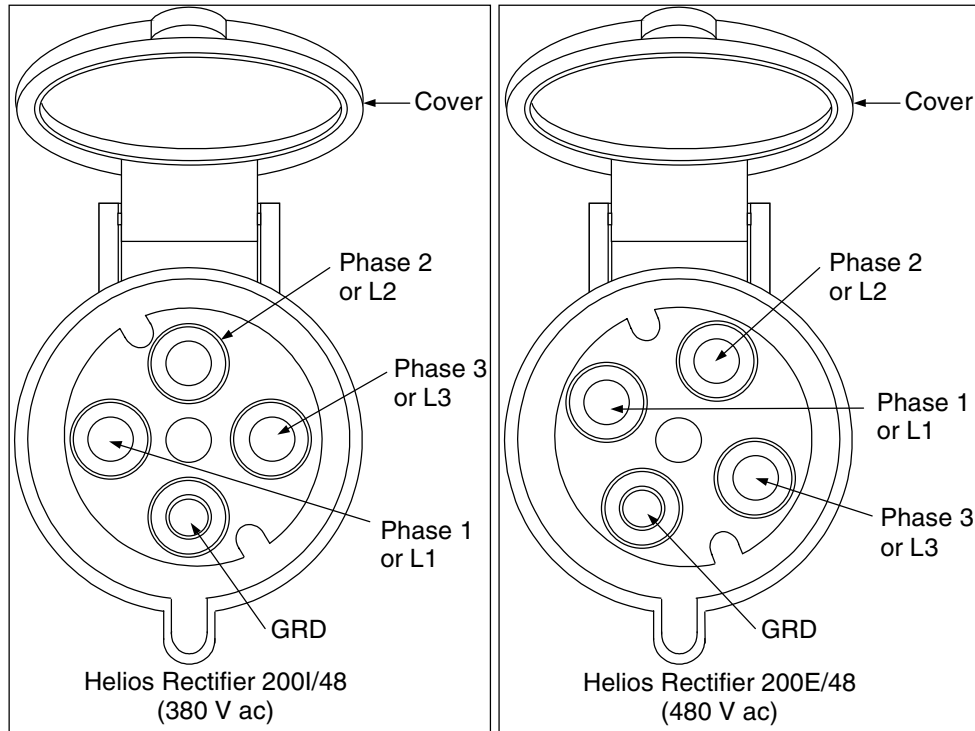
- end of the rectifier AC cord into the corresponding female receptacle behind the junction box. For the specific AC cable routing to be used with the Helios Rectifier 200E/48, refer to **Figure 35** in the case of a top fed system, or to **Figure 36** in the case of a bottom fed system.
11. Make the ground and line connections as applicable, at the AC service panel.
  12. Install the four bolts for the DC connections to the busbar risers at the rear of the cabinet.
  13. Plug one end of the control and signal cable supplied with the rectifier into the DB25 connector at the rear of the rectifier.
  14. Plug the other end of the control and signal cable into the corresponding connector on the interface circuit board at the top (top fed system) or bottom (bottom fed system) of the rectifier cabinet.
  15. Operate the AC circuit breaker of the new rectifier to the "ON" position.
  16. With the DC breaker in the "OFF" position, adjust the float, equalize and high voltage shutdown voltage levels as required. Refer to the appropriate rectifier user manual (see **6.0 - Reference Documents**).
  17. Install the corresponding sense fuse (RC) on the front of the controller.
  18. Ensure that the FLS/FS switch on the rectifier is set to the same position as that of the other rectifiers in the power system.
  19. Operate the DC circuit breaker of the rectifier to the "ON" position.
  20. Verify that the rectifier is sharing the load by observing its ammeter. It should display approximately the same value as the ammeters on the other rectifiers. If not, adjust its float and equalize voltage levels as described in the appropriate rectifier user manual (see **6.0 - Reference Documents**).

**Figure 32 AC connections in a Helios Rectifier 200E/48**

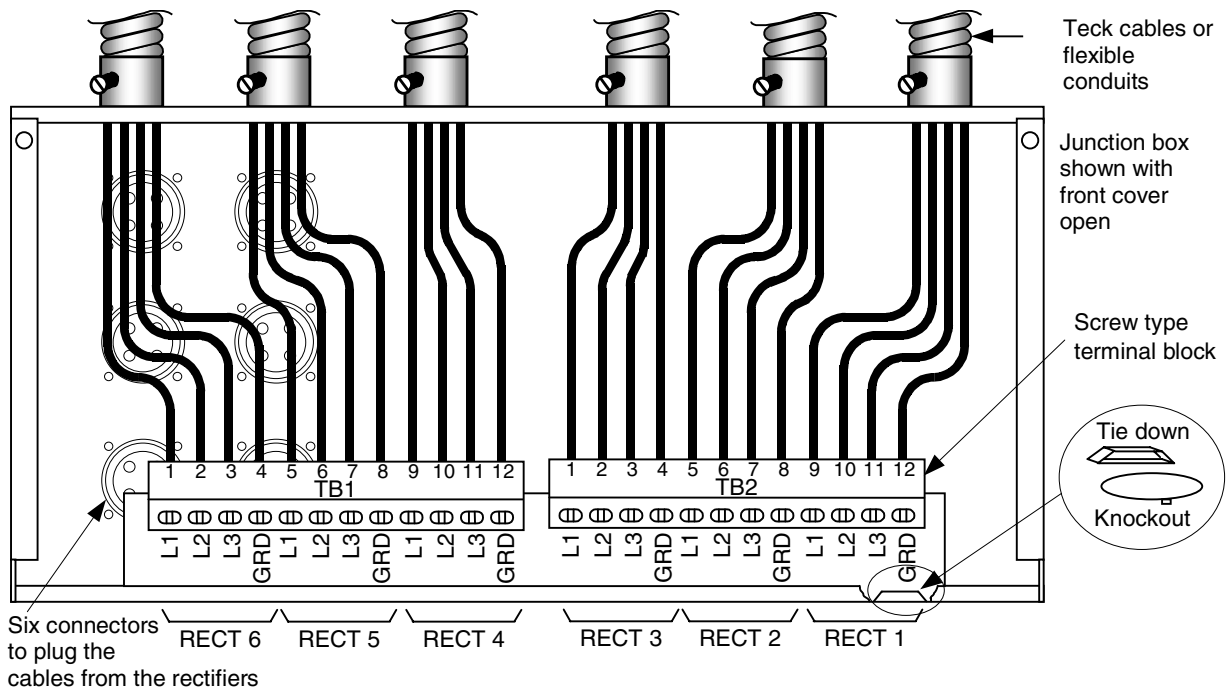




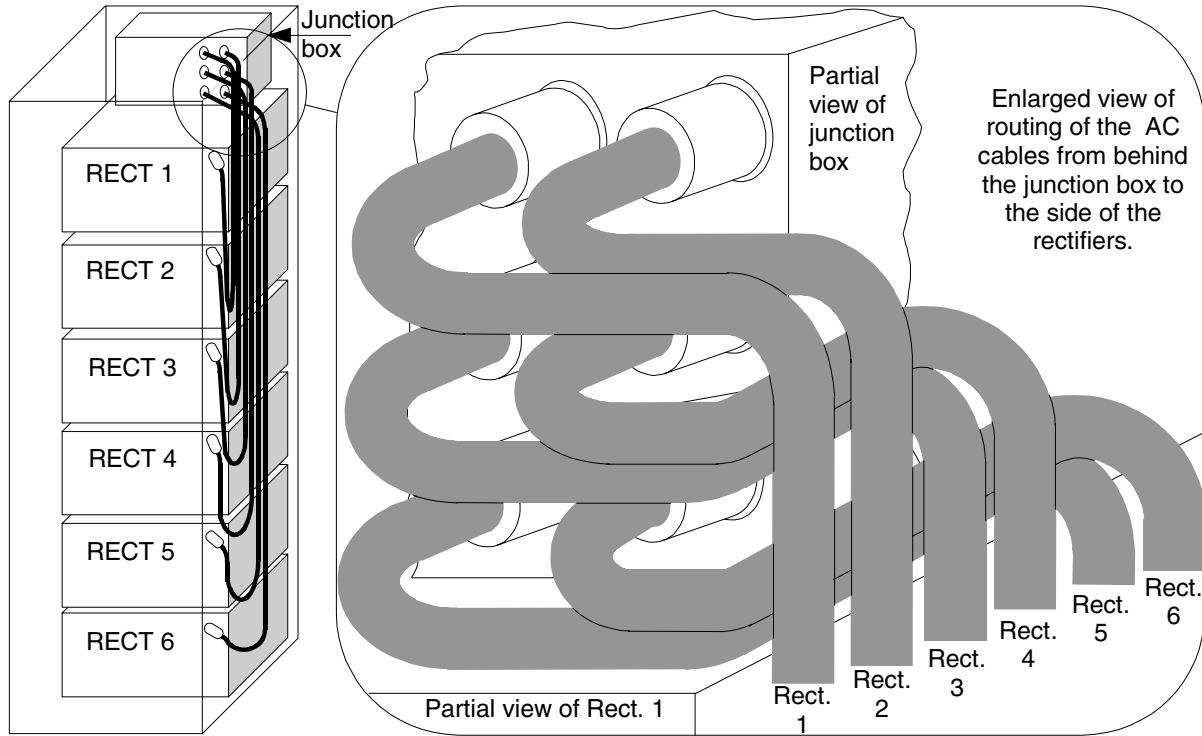
**Figure 33 AC connections in the female receptacle for a Helios Rectifier 200I/48 or a Helios Rectifier 200E/48**



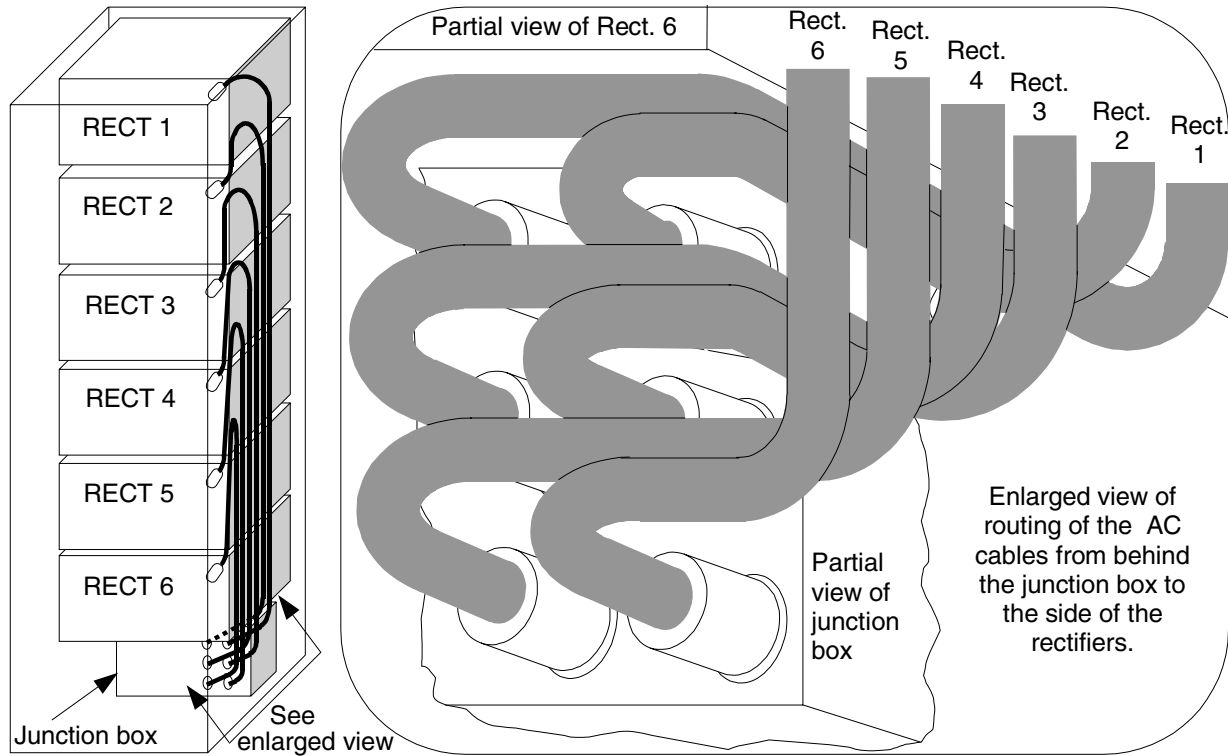
**Figure 34 AC connections inside the junction box (top fed shown) for a Helios Rectifier 200E/48**



**Figure 35 AC cable routing for the Helios Rectifiers 200E/48 in a top fed system**



**Figure 36 AC cable routing for the Helios Rectifiers 200E/48 in a bottom fed system**



---

### 5.3.2 Replacing a Rectifier

Replace a rectifier as described below for a Helios Rectifier 100/48 or as in **Replacing a Helios Rectifier 200I/48 or 200E/48**, whichever is applicable.

#### Replacing a Helios Rectifier 100/48

1. Notify the alarm center of incoming alarms during this procedure.
2. Turn OFF the AC and DC circuit breakers on the rectifier.
3. Remove the corresponding sense fuse on the front of the controller.
4. Remove the left and right rectifier retaining bars by loosening the screws.
5. Slide the rectifier out of the shelf carefully. Reuse the shipping carton of the new rectifier to store or ship the removed unit.
6. Ensure that the AC and DC circuit breakers on the new rectifier about to be plugged-in are in the "OFF" position (down).
7. Carefully slide the new rectifier into the shelf, ensuring that it is fully inserted.
8. Reinstall the left and right side clamping brackets removed in **Step 4** to secure the rectifier into position.
9. Operate the AC circuit breaker of the new rectifier to the "ON" position.
10. With the DC breaker in the "OFF" position, adjust the float, equalize and high voltage shutdown voltage levels as required. Refer to the appropriate rectifier user manual (see **6.0 - Reference Documents**).
11. Reinstall the sense fuse (RC) removed in **Step 3**.
12. Ensure that the FLS/FS switch on the rectifier is set to the same position as that of the other rectifiers in the power system.
13. Operate the DC circuit breaker of the new rectifier to the "ON" position.
14. Verify that the replacement rectifier is sharing the load by observing its ammeter. It should display approximately the same value as the ammeters on the other rectifiers. If not, adjust its Float and Equalize voltage levels as described in the appropriate rectifier user manual (see **6.0 - Reference Documents**).
15. Notify the alarm center of the end of the procedure.

---

## Replacing a Helios Rectifier 200I/48 or 200E/48

1. Notify the alarm center of incoming alarms during this procedure.
2. Turn OFF the AC and DC circuit breakers on the rectifier to be replaced.
3. Remove the corresponding sense fuse on the front of the controller.
4. At the AC service panel, place the AC circuit breaker associated with this rectifier in the OFF position.
5. For a Helios Rectifier 200E/48 without an AC cord, remove the AC protective cover at the rear of the rectifier and disconnect the AC cable inside the rectifier (refer to **Figure 32**).  
For a Helios Rectifier 200I/48 or 200E/48 equipped with an AC cord, unplug the AC cord from the supply receptacle.
6. Remove the four bolts for the DC connections to the busbar risers at the rear of the cabinet.
7. Disconnect the control and signal cable from the DB25 connector at the rear of the rectifier.
8. Remove the mounting screws securing the rectifier to the cabinet.
9. Carefully slide the rectifier out of the cabinet.  
**CAUTION:** Due to the weight of the rectifier (55 kg - 120 lb) a manual lift or at least two persons are required to remove the rectifier.  
Reuse the shipping carton of the new rectifier to store or ship the removed unit.
10. Ensure that the AC and DC circuit breakers on the front panel of the new rectifier are in the OFF position.
11. Lift the new rectifier to its position, rest it on the angle guides, and slide it into the cabinet.  
**CAUTION:** Due to the weight of the rectifier (55 kg - 120 lb) a manual lift or at least two persons are required to install the rectifier.
12. Align the mounting holes of the rectifier with those of the cabinet uprights and secure the rectifier in place using the eight mounting screws provided.  
**Note:** A star washer must be used on one of the mounting screws.
13. Reinstall the four bolts for the DC connections to the busbar risers at the rear of the cabinet (removed in **Step 6**).
14. Reconnect the control and signal cable into the DB25 connector at the rear of the rectifier (disconnected in **Step 7**).
15. Reconnect the AC cable disconnected in **Step 5** (or the AC cord that was unplugged).
16. At the AC service panel, place the AC circuit breaker associated with the rectifier in the ON position.
17. Operate the AC circuit breaker of the new rectifier to the "ON" position.
18. With the DC breaker in the "OFF" position, adjust the float, equalize and high voltage shutdown voltage levels as required. Refer to the appropriate rectifier user manual (see **6.0 - Reference Documents**).
19. Reinstall the sense fuse (RC) removed in **Step 3**.
20. Ensure that the FLS/FS switch on the rectifier is set to the same position as that of the other rectifiers in the power system.
21. Operate the DC circuit breaker of the rectifier to the "ON" position.
22. Verify that the rectifier is sharing the load by observing its ammeter. It should display approximately the same value as the ammeters on the other rectifiers. If not, adjust its float and equalize voltage levels as described in the appropriate rectifier user manual (see **6.0 - Reference Documents**).
23. Notify the alarm center of the end of the procedure.

---

### 5.3.3 Adding or Replacing a Battery String

For replacements, proceed from **Step 1** below. For new installations, go to **Step 5** of this procedure.



#### **WARNING**

**THIS PROCEDURE IMPLIES THAT ALL OR PART OF THE BATTERIES WILL BE MOMENTARILY TAKEN OUT OF SERVICE.**

**THIS WORK SHOULD THEN BE COMPLETED DURING REDUCED TRAFFIC HOURS AND/OR WITH A DIESEL GENERATOR BACKUP AVAILABLE TO ENSURE NO LOSS OF SERVICE DURING A POSSIBLE AC OUTAGE. IF MORE THAN ONE STRING IS TO BE REPLACED, REPLACE ONLY ONE STRING AT A TIME AND DO NOT DISCONNECT THE NEXT STRING BEFORE THE PREVIOUS ONE IS RECONNECTED.**

#### **1. Removal of the old string:**

Notify the alarm center of the possibility of incoming alarms during this procedure.

2. Above the battery stand, or at the top of the main cabinet for a 1500, 3000 or 4000 A system, or at the overhead busbars for a 6000 A system, locate, disconnect and isolate the charge leads (+ and -) coming from the batteries being replaced.
3. Disconnect the inter-cell connectors from the individual battery cells, and insulate each exposed terminal with electrician tape.
4. The removed batteries shall be disposed of in accordance with local, state and national environmental legislation.

#### **5. Installation of the new string:**

If this is an addition, locate and install the new battery stand according to the specifications and drawings. If this is a replacement, install the new battery string in the space vacated by the removed one.

6. Install the new batteries and use the new connecting material supplied with the batteries to interconnect them.
7. Perform the initial charging of this new battery string according to the battery manufacturer's specifications using an external power supply.
8. Above the battery stand, or at the top of the main cabinet for a 1500, 3000 or 4000 A system, or at the overhead busbars for a 6000 A system, connect the charge leads (+ and -) coming from the new batteries.
9. Notify the alarm center of the end of the procedure.

---

### 5.3.4 Replacement of a Distribution Fuse Block or Circuit Breaker



#### CAUTION

Precautions must be taken to avoid service interruptions.

Use properly insulated tools when working on the power distribution panels.

Replace a distribution fuse block as described below.

1. Notify the alarm center of incoming alarms during this procedure.
2. Remove the fuse from the fuse block to be replaced.
3. Remove the rear panels of the cabinet.
4. Carefully remove and insulate any load and alarm leads connected to the fuse block.
5. Carefully remove the fuse block.
6. Ensure that the fuse is removed from the new fuse block.
7. Carefully install the new fuse block.
8. Reconnect the load and alarm leads disconnected in **Step 4**.
9. Install the fuse in the fuse block.
10. Notify the alarm center of the end of this procedure.

#### Replacing a distribution circuit breaker

Replace a distribution circuit breaker as described below.

1. Notify the alarm center of incoming alarms during this procedure.
2. Place the circuit breaker to be replaced in the OFF position.
3. Remove the rear panels of the cabinet.
4. Carefully remove and insulate any load lead and alarm lead connected to the circuit breaker.
5. Carefully remove the circuit breaker.
6. Ensure that the new circuit breaker is in the OFF position before installing it.
7. Carefully install the new circuit breaker.
8. Reconnect the load and alarm leads disconnected in **Step 4**.
9. Turn on the circuit breaker
10. Notify the alarm center of the end of this procedure.

### 5.3.5 Replacing a Cabinet Alarm Lamp

Replace a cabinet alarm lamp as described below.

1. Remove the LP fuse on the controller (F31).
2. Unscrew and remove the lens cap on the cabinet alarm lamp unit.
3. Pull the defective light bulb out.
4. Insert the new light bulb.
5. Screw back the lens cap on the cabinet alarm lamp unit.
6. Reinstall the LP fuse on the controller (F31) removed in **Step 1**.

---

## 6.0 REFERENCE DOCUMENTS

---

Manual No.	Description
SL-60040	600 A and 1200 A Battery Disconnect Unit
SL-60014	TCM48 temperature compensation module
SL-60026	Voltage level limits for rectifiers and controllers
SL-60015	Helios Monitor 3000/48 remote surveillance unit
SL-60033	Helios DC System 4000/48 Installation manual
SL-60012	Helios Rectifier 100/48
SL-60036	Helios Rectifier 200I/48
SL-60037	Helios Rectifier 200E/48

---

## 7.0 LIST OF TERMS

---

<b>A</b>	ampere
<b>ABS</b>	alarm battery supply
<b>ABSF</b>	alarm battery supply fuse
<b>AC or ac</b>	alternating current
<b>ACO</b>	alarm cut-off
<b>AD</b>	Assembly drawing
<b>ADJ</b>	adjust or adjustment
<b>ALM</b>	alarm
<b>AMP</b>	ampere
<b>AUD</b>	audible
<b>AUX</b>	auxiliary
<b>AWG</b>	American wire gauging
<b>BAT</b>	battery
<b>BAT RTN</b>	battery return
<b>BDA</b>	battery disconnect alarm
<b>BDU</b>	battery disconnect unit
<b>BMU</b>	battery management unit
<b>BOD</b>	battery on discharge
<b>BODA</b>	battery on discharge alarm
<b>BPG</b>	building principal ground
<b>BR</b>	battery return
<b>BRR</b>	battery return reference
<b>CAL</b>	calibrate
<b>CFA</b>	charge fuse alarm
<b>CHG</b>	charge
<b>COM</b>	common
<b>CONT</b>	control
<b>CSA</b>	Canadian Standard Association
<b>CTRL</b>	control
<b>DC or dc</b>	direct current
<b>DFA</b>	distribution fuse alarm
<b>DISCH</b>	discharge
<b>DSPL</b>	display
<b>EB</b>	earthquake brace
<b>EMI</b>	electromagnetic interference
<b>EQL</b>	equalize
<b>ESD</b>	electrostatic discharge
<b>EXT</b>	external
<b>F</b>	fuse
<b>FA</b>	fuse alarm
<b>FG</b>	frame ground
<b>FGB</b>	floor ground bar
<b>FS</b>	forced sharing
<b>ft</b>	foot
<b>ft-lb</b>	foot-pound
<b>GRD or GRND</b>	ground
<b>HF</b>	high float
<b>HV</b>	high voltage
<b>HVA</b>	high voltage alarm



<b>HVSD</b>	high voltage shutdown
<b>HVSDA</b>	high voltage shutdown alarm
<b>HVSDR</b>	high voltage shutdown reset
<b>in.</b>	inch
<b>in.-lb</b>	inch-pound
<b>IS</b>	interconnect schematic
<b>ISG</b>	isolated system ground
<b>L</b>	line
<b>lb</b>	pound
<b>LED</b>	light emitting diode
<b>LF</b>	low float
<b>LOP</b>	loss of phase
<b>LV</b>	low voltage
<b>LVA</b>	low voltage alarm
<b>LVD</b>	low voltage disconnect
<b>LVDA</b>	low voltage disconnect alarm
<b>LVR</b>	low voltage reconnect
<b>m</b>	meter
<b>MAJ</b>	major
<b>MGB</b>	main ground bar
<b>MIN</b>	minor
<b>MNL</b>	manual
<b>MOP</b>	method of procedure
<b>MPS</b>	modular power shelf
<b>mV</b>	millivolt
<b>NC</b>	normally closed
<b>N-m</b>	Newton-meter
<b>NO</b>	normally open
<b>NORM</b>	normal
<b>psi</b>	pound per square inch
<b>PWR</b>	power
<b>RC</b>	Rectifier control
<b>RECT</b>	rectifier
<b>REF</b>	reference
<b>RFA</b>	rectifier failure alarm
<b>RPM</b>	remote power monitor
<b>RST</b>	reset
<b>SHT</b>	shunt
<b>SLS</b>	slope load share
<b>SPG</b>	single-point ground (connection)
<b>SW</b>	switch
<b>TB</b>	terminal block
<b>TCM</b>	temperature compensation module
<b>TP</b>	test point
<b>TR</b>	temporary release
<b>TST</b>	test
<b>UL</b>	Underwriters Laboratories
<b>V</b>	volt
<b>VRLA</b>	valve regulated lead acid (batteries)
<b>WD</b>	wiring diagram
<b>WVP</b>	water vapor pressure





## Helios DC System 4000/48

1500, 3000, 4000 & 6000 A

DC Power System

### Technical Support

U.S.A. 1-800-222-5877  
Outside the U.S.A. 614-841-6755  
U.K. +44 (0) 1793 553355  
France +33 1 4 87 51 52  
Germany +49 89 99 19 220  
Italy +39 2 98250 1  
Netherlands +00 31 475 503333  
E-mail [upstech@liebert.com](mailto:upstech@liebert.com)  
Web site <http://www.liebert.com>  
Worldwide FAX 614-841-5471  
tech support

### The Company Behind The Products

With more than 500,000 installations around the globe, Liebert is the world leader in computer protection systems. Since its founding in 1965, Liebert has developed a complete range of support and protection systems for sensitive electronics:

- Environmental systems: close-control air conditioning from 1.5 to 60 tons.
- Power conditioning and UPS with power ranges from 250 VA to more than 1000 kVA.
- Integrated systems that provide both environmental and power protection in a single, flexible package.
- Monitoring and control — on-site or remote — from systems of any size or location

Service and support, through more than 100 service centers around the world, and a 24-hour Customer Response Center.

While every precaution has been taken to ensure accuracy and completeness of this literature, Liebert Corporation assumes no responsibility, and disclaims all liability for damages resulting from use of this information or for any errors or omissions.

© 1998 Liebert Corporation. All rights reserved throughout the world. Specifications subject to change without notice.

® Liebert and the Liebert logo are registered trademarks of Liebert Corporation. All names referred to are trademarks or registered trademarks of their respective owners.

Printed in U.S.A.

SL-60030

## Free Manuals Download Website

<http://myh66.com>

<http://usermanuals.us>

<http://www.somanuals.com>

<http://www.4manuals.cc>

<http://www.manual-lib.com>

<http://www.404manual.com>

<http://www.luxmanual.com>

<http://aubethermostatmanual.com>

Golf course search by state

<http://golfingnear.com>

Email search by domain

<http://emailbydomain.com>

Auto manuals search

<http://auto.somanuals.com>

TV manuals search

<http://tv.somanuals.com>