



POWER AVAILABILITY

UPStation GXT 2U™

USER MANUAL



**2700VA
208V**



TABLE OF CONTENTS

IMPORTANT SAFETY INSTRUCTIONS	1
GLOSSARY OF SYMBOLS	3
INTRODUCTION	4
MAJOR COMPONENTS	5
Transient Voltage Surge Suppression (TVSS) and EMI/RFI Filters . . .	5
Rectifier/Power Factor Correction (PFC) Circuit	5
Inverter	5
Battery Charger	6
DC to DC Converter	6
Battery	6
Dynamic Bypass	6
GXT 2U (Rear View)	7
INSTALLATION	8
Preparation	8
Tower UPS Installation	8
Rack-Mount UPS Conversion and Installation	9
External Battery Cabinet Installation	13
CONTROLS AND INDICATORS	14
ON/Alarm Silence/Manual Battery Test Button	14
Standby/Manual Bypass Button	15
Load/Battery Level Indicators (4 Green, 1 Amber)	15
Fault Indicator LED (Red)	15
Bypass Indicator LED (Amber)	15
UPS ON Indicator LED (Green)	15
Battery Indicator LED (Amber)	15
AC Input Indicator LED (Green)	16
Output Voltage Selection	16
OPERATING INSTRUCTIONS	17
Normal Mode Operation	17
Bypass Mode Operation	17
Battery Mode Operation	17
Battery Recharge Mode	18

COMMUNICATIONS	19
Communications Interface Port	19
Pins 4 & 5 - Remote Shutdown on Battery	19
Pins 5 & 6 - Any-Mode Shutdown	20
Auto-Enable Output	20
Pin 6 Logic	20
UPS Intelligent Communications	21
CONFIGURATION PROGRAM	22
GXT 2U Configuration Program Abilities	22
What You Will Need	22
MAINTENANCE	23
Battery Replacement	23
Internal Battery Replacement Procedures	24
TROUBLESHOOTING	25
SPECIFICATIONS	30
BATTERY CABINET SPECIFICATIONS	31
BATTERY RUN TIMES	32
Product Warranty Registration	33

IMPORTANT SAFETY INSTRUCTIONS



WARNING

Opening or removing the cover may expose you to lethal voltages within this unit even when it is apparently not operating and the input wiring is disconnected from the electrical source. Observe all cautions and warnings in this manual. Failure to do so MAY result in serious injury or death. Refer all UPS and battery service to qualified service personnel. Do not attempt to service this product yourself. Never work alone.

SAVE THESE INSTRUCTIONS

This manual contains important safety instructions. Read all safety, installation, and operating instructions before operating the Uninterruptible Power System (UPS). Adhere to all warnings on the unit and in this manual. Follow all operating and user instructions. Individuals without previous training can install and operate this equipment.

It is not intended for use with life support and other designated “critical” devices. Maximum load must not exceed that shown on the UPS rating label. The UPS is designed for data processing equipment. If uncertain, consult your local dealer or Liebert representative.

This UPS is designed for use on a properly grounded (earthed), 50Hz or 60Hz, 208V supply (programmable for 200, 208, 220, 230, and 240VAC output). Installation instructions and warning notices are located in this manual.

ELECTROMAGNETIC COMPATIBILITY—The GXT 2U™ Series complies with the limits for a CLASS A DIGITAL DEVICE, PURSUANT TO Part 15 of FCC rules. Operation is subject to the following two conditions: (1) This device may not cause harmful interference, and (2) this device must accept any interference received, including interference that may cause undesired operation. Operating this device in a residential area is likely to cause harmful interference that users must correct at their own expense.

Operate the UPS in an indoor environment only in an ambient temperature range of 32°F to +104°F (0°C to +40°C). Install it in a clean environment, free from moisture, flammable liquids, gases and corrosive substances.

This UPS contains no user serviceable parts except the internal battery pack. The UPS ON/Standby push buttons do not electrically isolate internal parts. Under no circumstances attempt to gain access internally other than to replace the batteries due to risk of electric shock or burn. Do not continue to use the UPS if the front panel indications are not in accordance with these operating instructions or if the UPS performance alters in use. Refer all faults to your local dealer, Liebert representative or the Liebert Worldwide Support Group.

Servicing of batteries should be performed or supervised by personnel knowledgeable of batteries and the required precautions. Keep unauthorized personnel away from the batteries. **PROPER DISPOSAL OF BATTERIES IS REQUIRED. REFER TO YOUR LOCAL LAWS AND REGULATIONS FOR BATTERY DISPOSAL REQUIREMENTS.**

Never block or insert any object into the ventilation holes or other openings of the UPS.

DO NOT CONNECT equipment that could overload the UPS or demand half-wave rectification from the UPS, for example: electric drills, vacuum cleaners, laser printers or hairdryers.

Storing magnetic media on top of the UPS may result in data loss or corruption.

Turn the UPS off and isolate the UPS before cleaning; use only a soft cloth, never liquid or aerosol cleaners. Keep the front and rear vents free of dust accumulation that could restrict airflow.

When replacing batteries, replace with the same Liebert authorized replacement battery kits.



CAUTION

Do not dispose of battery or batteries in a fire. The battery may explode.

Do not open or mutilate the battery or batteries. Released electrolyte is harmful to skin and eyes. It may be toxic.



CAUTION

A battery can present a risk of electrical shock and high short circuit current. The following precautions should be observed when working on batteries:

- Remove watches, rings, and other metal objects.
- Use tools with insulated handles.

GLOSSARY OF SYMBOLS



Risk of electrical shock



Indicates caution followed by important instructions



AC input



AC output



Requests the user to consult the manual



Indicates the unit contains a valve-regulated lead acid battery



Recycle



DC voltage



Equipment grounding conductor



Bonded to ground



AC voltage



ON



Standby

INTRODUCTION

Congratulations on your choice of the Liebert UPStation GXT 2U™ Uninterruptible Power System (UPS). It provides conditioned power to microcomputers and other sensitive electronic equipment.

Upon generation, AC power is clean and stable. However, during transmission and distribution it may be subject to voltage sags, spikes, or complete power failure that may interrupt computer operations, cause data loss, or even damage equipment. The UPStation GXT 2U protects equipment from these disturbances.

The UPStation GXT 2U is rated for 2700 VA, 1890 watts. Complete model specifications appear at the end of this manual.

The UPStation GXT 2U is a compact, “on-line” UPS. An on-line UPS continuously conditions and regulates its output voltage, whether utility power is present or not. It supplies connected equipment with clean sinewave power. Sensitive electronic equipment operates best from sinewave power.

For ease of use, the UPStation GXT 2U features a light-emitting diode (LED) display to indicate either load percentage or battery capacity depending upon the mode of operation. It also provides self-diagnostic tests, a combination ON/Alarm Silence/Manual Battery Test button, a Standby button, user configurable program, and two levels of alarms when the unit is operating on battery.

The UPStation GXT 2U has an interface port for communication between the UPS and a network server or other computer systems. This port provides detailed operating information including voltages, currents, and alarm status to the host system when used in conjunction with Liebert MultiLink™ software. MultiLink software can also remotely control UPS operation.

MAJOR COMPONENTS

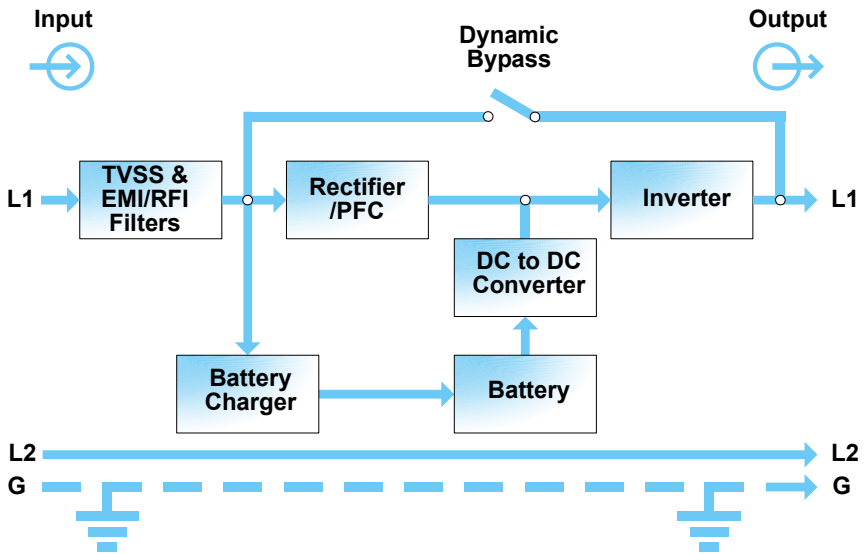

TRANSIENT VOLTAGE SURGE SUPPRESSION (TVSS) AND EMI/RFI FILTERS

These UPS components provide surge protection and filter both electromagnetic interference (EMI) and radio frequency interference (RFI). They minimize any surges or interference present in the utility line and keep the sensitive equipment protected.

RECTIFIER/POWER FACTOR CORRECTION (PFC) CIRCUIT

In normal operation, the rectifier/power factor correction (PFC) circuit converts utility AC power to regulated DC power for use by the inverter while ensuring that the waveshape of the input current used by the UPS is near ideal. Extracting this sinewave input current achieves two objectives:

- The utility power is used as efficiently as possible by the UPS.
- The amount of distortion reflected on the utility is reduced.

This results in cleaner power being available to other devices in the building not being protected by the UPStation GXT 2U.

INVERTER

In normal operation, the inverter utilizes the DC output of the power factor correction circuit and inverts it into precise, regulated sinewave AC power. Upon a utility power failure, the inverter receives its required energy from the battery through the DC to DC converter. In both modes of operation, the UPS inverter is on-line and continuously generating clean, precise, regulated AC output power.

BATTERY CHARGER

The battery charger utilizes energy from the utility power and precisely regulates it to continuously “float charge” the batteries. The batteries are being charged whenever the UPStation GXT 2U is plugged in, even when the UPS is not turned on.

DC TO DC CONVERTER

The DC to DC converter utilizes energy from the battery system and raises the DC voltage to the optimum operating voltage for the inverter. This allows the inverter to operate continuously at its optimum efficiency and voltage, thus increasing reliability.

BATTERY

The UPStation GXT 2U utilizes valve-regulated, nonspillable, flame retardant, lead acid batteries. To maintain battery design life, operate the UPS in an ambient temperature of 68°F to 77°F (20°C to 25°C). Optional external battery cabinets are available to extend battery run times.

DYNAMIC BYPASS

The UPStation GXT 2U provides an alternate path for utility power to the connected load in the unlikely event of a UPS malfunction. Should the UPS have an overload, overtemperature, or UPS failure condition, the UPS automatically transfers the connected load to bypass. Bypass operation is indicated by an audible alarm and illuminated amber Bypass LED (other LEDs may be illuminated to indicate the diagnosed problem). To manually transfer the connected load from the inverter to bypass, press the Standby button once.



NOTE

The bypass power path does NOT protect the connected equipment from disturbances on the utility supply.

GXT 2U (REAR VIEW)

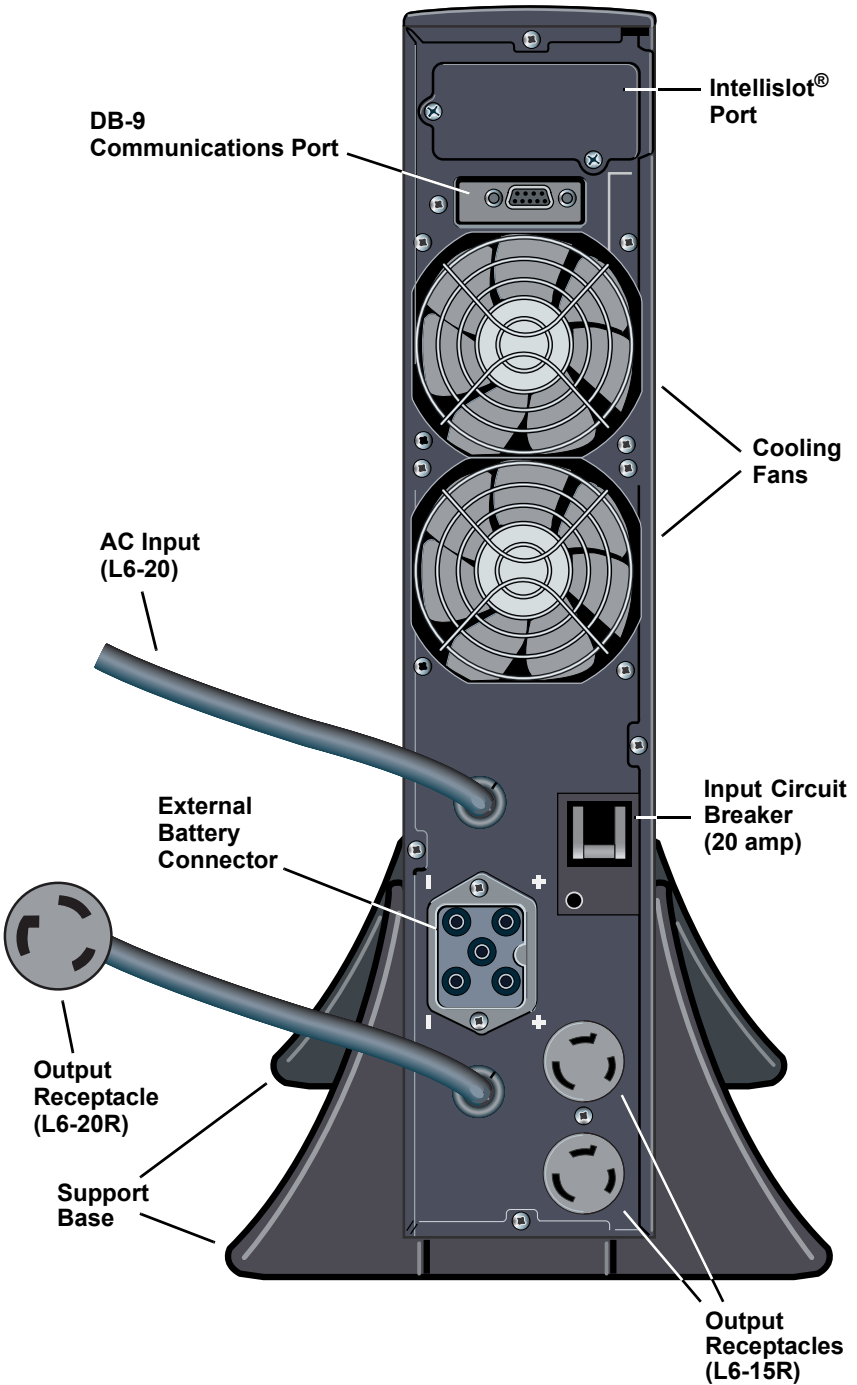

INSTALLATION

PREPARATION

1. Visually inspect the UPS for freight damage. Report damage to the carrier and your local dealer or Liebert representative.



CAUTION

The UPS is heavy (see **Specifications** section). Take proper precautions when lifting or moving it.

2. Decide where to place the GXT 2U. Install the UPS indoors in a controlled environment, where it cannot be accidentally turned off. Place it in an area of unrestricted airflow around the unit, away from water, flammable liquids, gases, corrosives, and conductive contaminants. Maintain a minimum clearance of 4 inches (100mm) in the front and rear of the UPS. Maintain an ambient temperature range of 32°F to 104°F (0°C to 40°C).



NOTE

UPS operation in temperatures above 77°F (25°C) reduces battery life.

3. The GXT 2U may be installed in either a tower configuration or in a rack, depending on available space and use considerations. Determine the type of installation and follow the appropriate instructions in either **Tower UPS Installation** or **Rack-Mount UPS Conversion and Installation**.

TOWER UPS INSTALLATION

When using the GXT 2U in a tower configuration, use the included support base (shown below, left) to stabilize the UPS.

If any battery cabinets are added, they will include spacers to accommodate the additional cabinets (shown below, right).

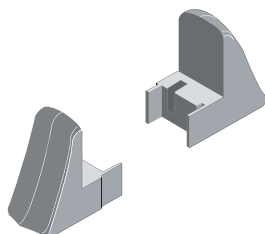

Support base

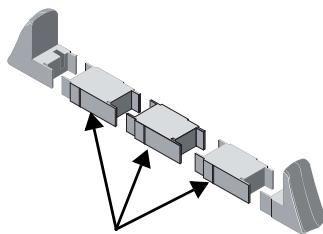

Spacers added to support base to accommodate additional battery cabinets

RACK-MOUNT UPS CONVERSION AND INSTALLATION



NOTE

When rack mounted, the UPS must be supported by a shelf, brackets or slide rails on each side. The rack mount handles WILL NOT support the weight of the UPS. They are used to move the UPS into and out of the rack.

1. For slide rail installations, first remove the top/side fin. Slide the top/side fin forward, then lift it up to remove. If desired, install the optional rack mount handles that were shipped with the UPS.

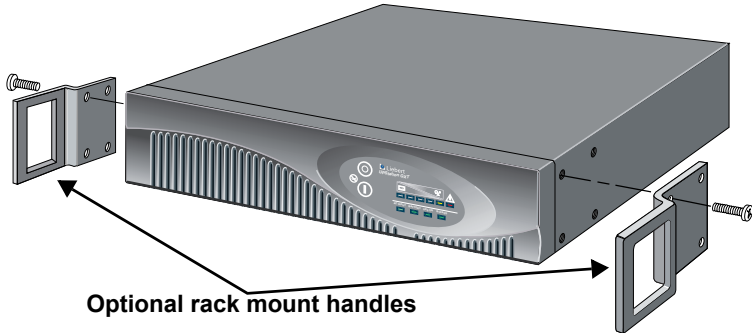

Securing hardware and slide rails are sold separately. Contact your local dealer or Liebert representative for these additional options and any assistance needed.

2. Unpack the two (2) rack-mounting bracket assemblies and mounting hardware from the rack-mounting kit (P/N: RMKIT18-32). Bracket assemblies are interchangeable between left-hand or right-hand. Remove inner member of each bracket assembly as shown at right by extending it to its outermost position, depressing the retaining latch and then pulling inner member from bracket assembly.

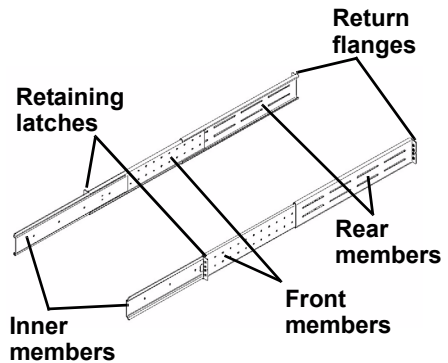

- Determine the height position inside the rack enclosure where you want to mount the UPS or battery cabinet.



CAUTION

Reduce risk of tipping the rack enclosure by placing UPS or battery cabinet in the lowest possible rack position.

Install rear member of each bracket assembly into rack enclosure with two (2) M5 screws provided in this kit. (See figure at right.) Return flanges on bracket assembly fit to the inside of rack mounting rails. Insert screws loosely (finger-tight) into top and bottom holes of return flange on rear member. Extend bracket assembly by sliding front member forward until it touches the front rack mounting rail. Insert two (2) M5 screws loosely (finger-tight) into top and bottom holes of return flange on each front member. Make sure bracket assemblies are at the same mounting height on all four (4) rack mounting rails.

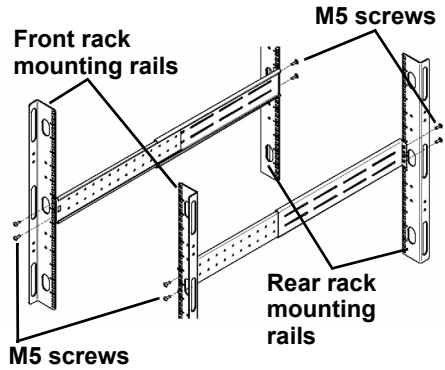

- Locate eight (8) M4 screws and eight (8) M4 nuts from hardware pack in this kit. Each nut has a locking, nylon insert that begins gripping the screw when it is halfway tight. Make sure to tighten nut and screw completely to assure locking action. Fasten rear member and front member together using four (4) screws and four (4) nuts per bracket assembly as shown in the figures at right. For maximum support, locate fasteners for each bracket assembly as far apart as possible, depending on rack depth, while still joining both members (See figures at right). Check alignment of bracket assemblies and **TIGHTEN ALL SCREWS FROM STEPS 3 and 4.**

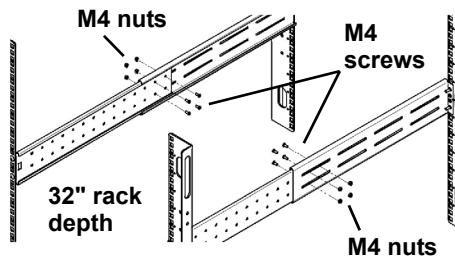
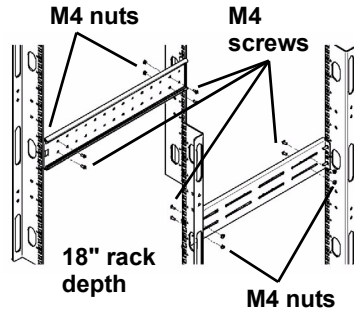

- Prepare the UPS or battery cabinet (the "equipment") for rack mounting by following instructions in the equipment's user manual. The equipment may require additional parts to be added or parts to be removed for rack mounting. After it is prepared, lay equipment in rack-mounting position. Fasten inner members from **Step 2** to the equipment on both sides as shown in the figure at right with (8) M4 screws provided in this kit. Make sure retaining latch is near the rear of the equipment as shown in the figure at right.

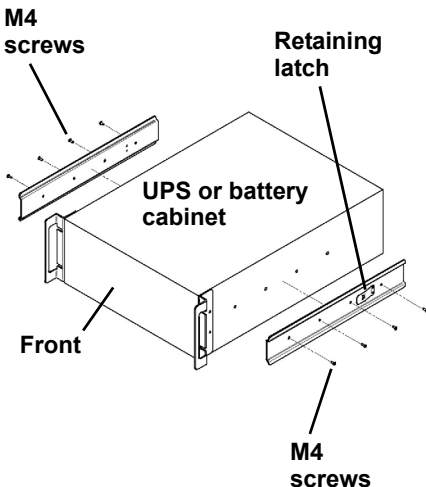

- Open grease packet provided in this kit. Apply a 1" long bead of grease four (4) places inside the bottom, curved tracks of front members as shown at right. The grease will allow the equipment to slide into the bracket assemblies more easily.

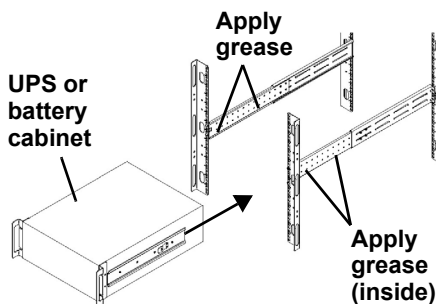

CAUTION

Lifting equipment into rack may be a two-person job, depending on weight of equipment. See equipment's user manual.

- Insert the equipment, with inner members attached from **Step 5**, into bracket assemblies by inserting top and bottom edges of inner members into the top and bottom, curved tracks of front members and sliding the equipment into rack (see figure in **Step 6**). Ends of inner members are tapered to allow rear of the equipment to be angled upward before insertion, if space allows.

Then the rear, bottom edges of inner members can be placed into front edge of bottom tracks, and the front of the equipment can be tipped up into horizontal position to insert the top edges of inner members before sliding the equipment into rack (see figure at right). The equipment should move smoothly into bracket assemblies. If not, recheck alignment of front and rear members from **Steps 3** and **4**.

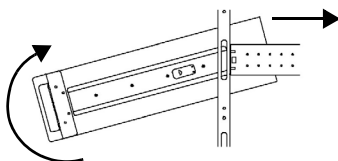

8. Secure front of the equipment to rack mounting rails to prevent the equipment from sliding out of position. If securing holes are provided on front of the equipment that align with the center holes on return flange of front members, you can use the four (4) extra M5 screws provided in this kit to secure the equipment. Otherwise, the equipment should be secured to front of rack mounting rails with four (4) customer-supplied fasteners.

9. To orient the display for horizontal viewing, remove the front plastic bezel by pulling forward evenly on both sides. The unit has two front panel overlays. Remove the outer overlay (used for tower installation). This reveals a horizontally oriented front panel overlay for rack mounting. Snap the front bezel back into place.



10. Once the UPS is installed in the rack, the load may be connected. Ensure the load equipment is turned off; plug all loads into the output receptacles on the rear of the UPS.

11. Plug the UPS into a dedicated wall receptacle properly protected by a circuit breaker or fuse in accordance with national and local electrical codes. Use a 20 amp rated device for the 2700VA, 208V unit. The wall receptacle must be grounded.

12. Turn ON the UPS by pressing the ON button; then turn on the connected load equipment. The UPS is now providing conditioned power to your equipment.

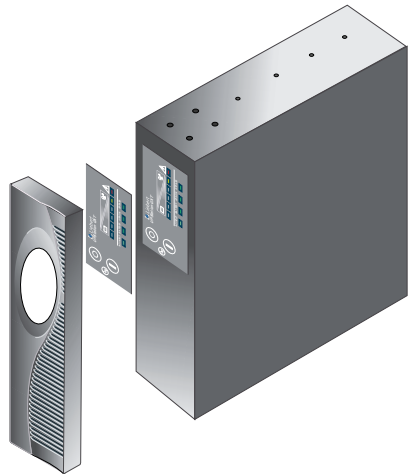

EXTERNAL BATTERY CABINET INSTALLATION

Optional Liebert external battery cabinets may be connected to the UPS to provide additional battery run time. External battery cabinets are designed to be placed all on one side of the UPS or stacked beneath the UPS. There is no limit to the number of external battery cabinets that can be used but each cabinet will increase the battery recharge time.



CAUTION

The external battery cabinet(s) are heavy (see **Specifications** section). External battery cabinets can be used in rack-mount or tower configuration. Take proper precautions when lifting them.

1. Visually inspect the external battery cabinet for freight damage. Report damage to the carrier and your local dealer or Liebert representative.
2. For slide rail installations, first remove the top/side fin. Top/side fin slides forward and then lift up to remove. Optional rack-mount handles are shipped with the external battery cabinet and may be installed at this time if desired.
3. Securing hardware and slide rails are sold separately. Please contact your local dealer or Liebert representative for these additional options and any assistance needed. Fasten the slides into position with the screws per the instructions included with the slide rails.
4. Use the enclosed support bases for the tower option to prevent tip-over. One additional set of support base extensions ships with each external battery cabinet.
5. Connect the supplied external battery cabinet cable to the rear of the external battery cabinet, then to the rear of the UPS.
6. Turn ON the battery breaker on the rear of the external battery cabinet.
7. The UPS is now equipped with additional backup battery run time. For approximate battery run times, refer to the **Battery Run Times** charts in this manual.

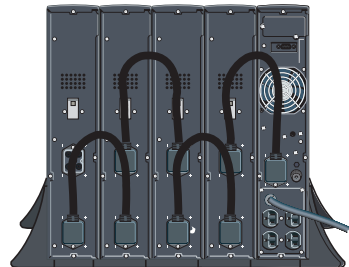
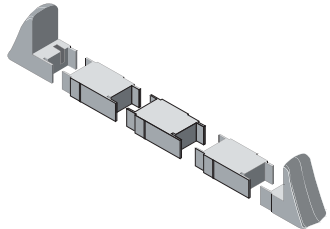

NOTE

*You must use the included Configuration Program to specify the number of external battery cabinets connected to the UPS. For more information, see **Configuration Program** on page 22.*

CONTROLS AND INDICATORS

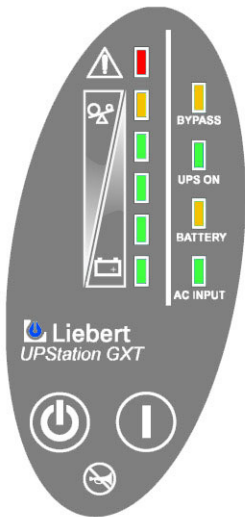

All LEDs illuminated for illustrative purposes only.

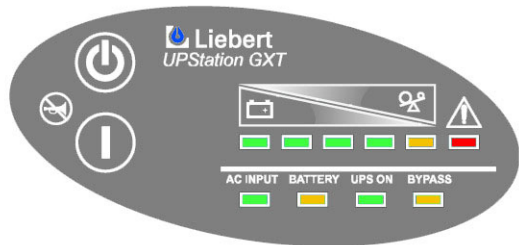

ON/Alarm Silence/Manual Battery Test Button

This button controls output power to connected load(s) and has three functions:

- ON
- Alarm Silence
- Manual Battery Test

ON - Pressing this button will start up the UPS in order to provide conditioned and protected power.

Alarm Silence - To silence alarms, press this button for at least one second. After the alarm is silenced, the UPStation GXT 2U will reactivate the alarm system to alert of additional problems.



NOTE

The LOW BATTERY and BYPASS reminder alarms CANNOT be silenced.

Manual Battery Test - To initiate a manual battery test, press the ON button for at least one second while operating from utility power with no alarm conditions present.

- If only three of the five Battery LEDs illuminate, allow the UPS to recharge the batteries for 24 hours.
- After 24 hours, retest the batteries.
- After the batteries have been retested, if only three of the five Battery LEDs illuminate, contact your local dealer, Liebert representative or Liebert Worldwide Support Group.

Standby/Manual Bypass Button



This button controls output power to connected load(s) and has dual functions: Standby and Manual Bypass.



CAUTION

While the UPS is in Normal Mode operation, pressing the Standby/ Manual Bypass button once will put the UPS into Bypass Mode.

Once the UPS is in Bypass Mode operation, press the Standby/ Manual Bypass button two distinct times (for about one second each time) to turn off the UPS. Perform all necessary shutdown procedures on connected loads before turning off the UPS.

Load/Battery Level Indicators (4 Green, 1 Amber)

The load/battery level indicators have dual functions. During normal mode operation LED indicators display the approximate electrical load placed upon the UPS; and during battery mode operation LED indicators display approximate battery capacity.

The UPStation GXT 2U is equipped with automatic and remote battery test features. The automatic test occurs every 14 days (this option is user configurable) if utility has not been interrupted. Should the battery fail this test, the red Fault indicator LED along with the A and C diagnostic LEDs will illuminate and an alarm will sound (refer to **Troubleshooting** section). The remote test feature functions with MultiLink 3 software and can remotely initiate the battery test.

Fault Indicator LED (Red)

The Fault indicator LED is illuminated if the UPS has detected a problem. Also, one or more of the load/battery level indicators may be illuminated (refer to **Troubleshooting** section).

Bypass Indicator LED (Amber)

The Bypass indicator LED is illuminated when the UPS is operating from bypass power. An alarm will sound indicating the UPS detected a problem, or the manual bypass function has been activated.

UPS ON Indicator LED (Green)

The UPS ON indicator LED is illuminated when the UPS inverter is operating and supplying power to your connected loads.

Battery Indicator LED (Amber)

The Battery indicator LED is illuminated when the UPS is operating on battery.

AC Input Indicator LED (Green)

The AC Input indicator LED is illuminated when utility power is available and within the input specifications.

Output Voltage Selection

The Output Voltage is user configurable and is designed to allow selecting or changing the desired output voltage to match the utility via the GXT 2U Configuration Program provided with the UPS. The settings to choose from are 200, 208, 220, 230, and 240 VAC output. The factory default setting is 208 VAC.



CAUTION

Never change the voltage settings while the UPS is ON and powering connected loads.



NOTE

Setting output voltage to 200 VAC will cause the UPS unit to be derated to 2400 VA, 1680 watts.

OPERATING INSTRUCTIONS

NORMAL MODE OPERATION

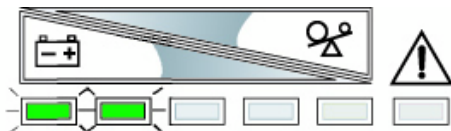

During normal operation, utility power provides energy to the UPS. The filters, power factor correction circuit and the inverter process this power to provide computer grade power to connected loads. The UPS maintains the batteries in a fully charged state.

AC INPUT BATTERY UPS ON BYPASS



Normal Mode Operation at 26-50%

The four green load level LEDs indicate an approximate level of load in 25% increments. If the UPS becomes loaded beyond full rating, the fifth (amber) LED indicator will illuminate and the UPS will sound an audible alarm. The display template indicates the percentage of load (26-50% of load shown in the example above) on the UPS output.

BYPASS MODE OPERATION

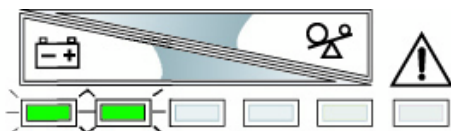

Bypass mode occurs when the OFF button is pressed once while the UPS is in Normal Mode. During bypass operation, utility power provides energy to the UPS. The utility power bypasses the inverter and provides power for the connected load.

AC INPUT BATTERY UPS ON BYPASS



Bypass Mode Operation at 26-50%

The four green load level LEDs indicate an approximate level of load in 25% increments. If the UPS becomes loaded beyond full rating, the fifth (amber) LED indicator will illuminate and the UPS will sound an audible alarm. The display template indicates the percentage of load (26-50% of load shown in the example above) on the UPS output.



CAUTION

Turning OFF the UPS while in bypass mode will result in loss of output power.

BATTERY MODE OPERATION

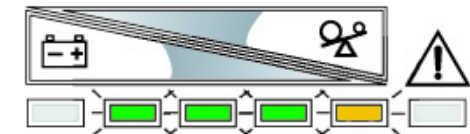

Battery mode occurs in event of an extreme input voltage condition or complete utility failure. The battery system supplies power through the DC to DC converter to the inverter to generate power for the connected load.

AC INPUT BATTERY UPS ON BYPASS

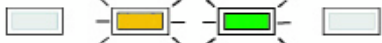

Battery Mode Operation at 80-61%

During battery mode an alarm sounds every 10 seconds. This will change to two beeps every 5 seconds when the battery runs low (approximately 2 minutes remaining, but this is user configurable). The AC Input LED will extinguish, and the Battery LED will illuminate to warn that a utility problem has occurred. Each battery level indicator represents a 20% capacity level. As capacity decreases, fewer indicators remain illuminated. Refer to **Troubleshooting** section.

For approximate battery run times, refer to the **Battery Run Times** charts in this manual. These times are approximates based on resistive load and an ambient temperature of 77°F (25°C). To increase this time, turn off non-essential pieces of equipment (such as idle computers and monitors) or add the optional external battery cabinet.



CAUTION

Turning OFF the UPS while in battery mode will result in loss of output power.

BATTERY RECHARGE MODE

Once utility power is restored, the UPS resumes normal operation. At this time, the Battery Charger begins recharging.

COMMUNICATIONS

COMMUNICATIONS INTERFACE PORT

The UPStation GXT 2U UPS has a standard DB-9 serial port female connector located on the rear of the UPS unit. Several signals are provided on this port and are assigned as follows:

Pin	Assignment Description
1	Low Battery (open collector)
2	UPS TxD (typical RS-232 levels)
3	UPS RxD (typical RS-232 levels)
4	Remote Shutdown (5-12VDC, 10-24 mA max); battery operation
5	Common
6	Remote Shutdown (short to pin 5); all modes of operation
7	Low Battery (open emitter)
8	Utility Fail (open emitter)
9	Utility Fail (open collector)

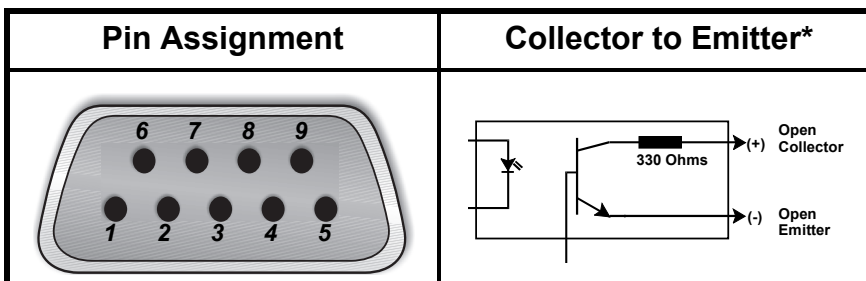

* Maximum voltage and current on pins 1, 7, 8, and 9 is 60VDC; 10.0 mA.

PINS 4 & 5 - REMOTE SHUTDOWN ON BATTERY

1. This pin is functional only when the UPS is in battery mode. If the UPS is being powered by the utility, Pin 4 will ignore any signal on this pin.
2. Pin 4 requires a 5-12 VDC signal to shutdown. This normally comes from the serial port using Liebert's contact closure cable. It cannot be used with just a contact closure unless the relay is used to switch a voltage source. A 5-12 VDC signal for 1.5 seconds or greater is required to signal a shutdown. Signals for less than 1.5 seconds will be ignored. After Pin 4 receives a shutdown signal for 1.5 seconds, the command cannot be canceled.

3. A battery shutdown signal on Pin 4 will NOT cause an immediate shutdown. A shutdown signal will start a 2-minute shutdown timer. The timer cannot be stopped. After 2 minutes, the UPS will shut down.
4. If the utility returns during the 2-minute timer countdown, the shutdown timer will continue until the end of 2 minutes and the UPS will turn OFF. The UPS must remain OFF for at least 10 seconds even if AC input power returns before the UPS turns OFF. This serves to reset and restart the server.

Whether the UPS turns back ON when power is restored depends on the auto-restart setting: enabled or disabled.

If the auto-restart is disabled, the UPS will not restart after performing the 2-minute shutdown delay.

PINS 5 & 6 - ANY-MODE SHUTDOWN

1. Pin 6 of the 9-pin communication connector is used for “Any-Mode Shutdown” of the UPS output. This control input may be used in special applications to disable the UPS output power—both Inverter and Bypass.
2. The Options tab allows the behavior of the Any-Mode Shutdown feature to be modified. When the program opens, or the REFRESH button is pressed, the UPS setting is read by the configuration program and displayed.

Auto-Enable Output



WARNING

Note that when this option is selected and the UPS output is disabled using Pin 6, the UPS output can turn on automatically and without warning if the Pin 6 connection is changed.

Pin 6 Logic



WARNING

DO NOT CHANGE THIS OPTION from the factory default setting unless you are ready to install a normally-closed connection between Pins 5 & 6. This connection must be maintained to use the UPS or to use the configuration program again, including the ability to change the UPS setting back to the default setting using the configuration program via a serial communication link.

If version 1.6 (or later) is used with an earlier GXT 2U model (with an earlier UPS firmware version), the Any-Mode Shutdown features cannot be changed.

If the configuration program is used with an earlier UPS model (with an earlier UPS firmware version) that does not support the modification of these settings, the Options tab will display a reminder of the factory default settings. These cannot be changed.

UPS INTELLIGENT COMMUNICATIONS

The UPStation GXT 2U is equipped with an Intellislot® port to provide advanced communication and monitoring options.

Liebert's MultiLink software continually monitors the UPS and can shut down your computer or server in the event of an extended power failure.

MultiLink can also be configured for use without the serial cable when the Intellislot SNMP/Web card is installed in the UPS. Additionally, MultiLink can be configured to coordinate shutdown across the network with other computers running MultiLink when you purchase a MultiLink License Kit. For more information about the Intellislot SNMP/Web Card and MultiLink License Kits, visit our Web site (www.liebert.com) or contact your local dealer or Liebert representative.

Several option cards are available for use in the Intellislot port of the UPStation GXT 2U. The Intellislot SNMP/Web Card provides SNMP and Web-based monitoring and control of the UPS across the network.

The Intellislot MultiPort 4 Card allows you to install MultiLink software on four computers and coordinate shutdown in the event of a power failure.

The Intellislot Relay Card provides dry contact relay outputs for custom-wired applications and delivers support for built-in shutdown for AS/400 systems.



CAUTION

To maintain safety (SELV) barriers and for electromagnetic compatibility, signal cables should be segregated and run separate from all other power cables, where applicable.

CONFIGURATION PROGRAM

This is a new feature included with the new UPStation GXT 2U line. Several UPS settings that were previously not available or required custom manufacturing may now be modified using this program. For most users, the factory default settings will be adequate. This manual illustrates the features available for modification, as well as the factory default setting.



NOTE

The UPS must be turned off—and not powering connected equipment—before you make any changes to configuration settings.

While the UPS is in Normal Mode operation, press the OFF button once to put the UPS into Bypass Mode.

Once the UPS is in Bypass Mode operation, press and release the OFF button two distinct times (for about a second each time) to turn off the UPS.

GXT 2U CONFIGURATION PROGRAM ABILITIES

- Select one of five output voltages to match voltages found around the world.
- Enable/Disable Auto-Restart.
- Select frequency converter operation with a fixed output frequency of 50 or 60 Hz.
- Set the Low Battery Warning alarm time from 2 to 30 minutes.
- Enable/Disable the Auto-Battery test.
- Set the Auto-Battery test to 7, 14, 21, or 28 days.
- Select the number of external battery cabinets connected to the UPS to adjust the remaining run time calculations reported by Liebert software products.
- Modify the shutdown setting of DB-9 pin 6 (for information on pin assignments, see **Communications** on page 19).



NOTE

This program is compatible with UPS models beginning with “GXT2-”, as in “GXT2-2700RT208.” It is not compatible with earlier versions of UPStation GXT UPS.

What You Will Need

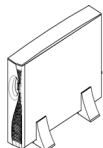

In addition to the GXT 2U UPS, you will need the configuration program diskette and serial cable (beige or tan, 3-wire: GND, TX, RX; straight through 2-2, 3-3, 5-5) included in the UPS accessory box. The BLACK ML9P9S CONTACT CLOSURE communication cable IS NOT compatible with the configuration program. A Windows 95[®], 98[®], or NT[®] computer—desktop or laptop—is also required to set up and run the configuration program.

MAINTENANCE

The UPStation GXT 2U requires very little maintenance. The batteries are valve-regulated, nonspillable, flame retardant, lead acid, and should be kept charged to obtain their designed life. The UPS continuously charges the batteries when connected to the utility supply.

When storing the UPS for any length of time, it is recommended to plug the UPS in for at least 24 hours every four to six months to ensure full recharge of the batteries.

The UPStation GXT 2U is designed to allow the user to safely replace the internal batteries. Read the safety cautions before proceeding. Contact your local dealer or Liebert representative to obtain the appropriate replacement battery kit part number and pricing.

BATTERY REPLACEMENT



CAUTION

A battery can present a risk of electrical shock and high short circuit current. The following precautions should be observed before replacing the batteries:

- Remove rings, watches, or other metal objects.
- Use a Phillips (crosshead) screwdriver with insulated grips.
- Do not lay tools or other metal objects on top of the batteries.
- If the battery replacement kit is damaged in any way or shows signs of leakage, contact your local dealer or Liebert representative immediately.
- Do not dispose of batteries in a fire. The batteries may explode.

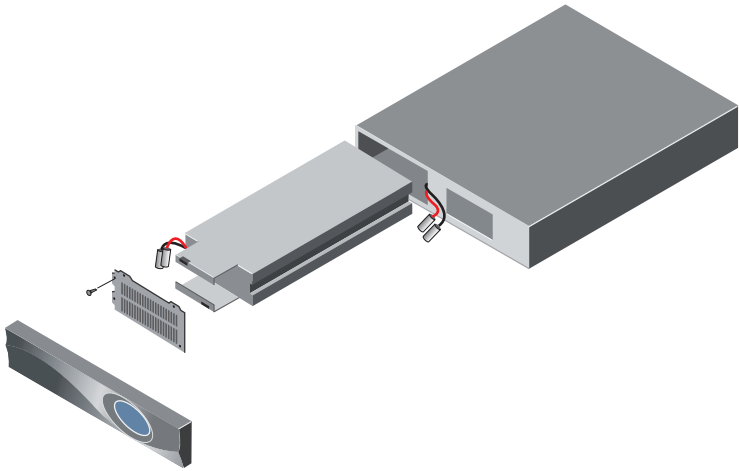

Internal Battery Replacement Procedures

1. Gently remove the front plastic bezel cover from the UPS.
2. Loosen and remove the four screws on the front battery door. Lay the battery door aside for reassembly.
3. Gently pull battery wiring out and disconnect the two slotted battery connectors.
4. Grasp the battery pack assembly, and pull it out of the front of the UPS.
5. Unpack the new battery assembly taking care not to destroy the packing. Compare new and old battery assemblies to make sure they are the same. If so, proceed with **Step 6**; otherwise STOP and contact your local dealer, Liebert representative, or the Liebert Worldwide Support Group.
6. Line up and slide in the new replacement battery pack.
7. Reconnect the two slotted battery connectors and gently push the battery wiring and battery pack assembly back into the UPS.
8. Reattach the front battery door with the four screws.
9. Reattach the front plastic bezel cover to the UPS.



NOTE

These are hot-swappable replacement batteries. However, caution should be exercised because during this procedure the load is unprotected from disturbances and power outages.

TROUBLESHOOTING

The information below indicates various symptoms a user may encounter in the event the UPStation GXT 2U develops a problem. Use this information to determine whether external factors caused the problem and how to remedy the situation.

1. The Fault indicator will illuminate, indicating the UPS detected a problem.
2. An alarm will sound, alerting that the UPS requires attention.
3. One or more additional load/battery level LED indicators will be illuminated to provide a diagnostic aid to the operator, as described below:

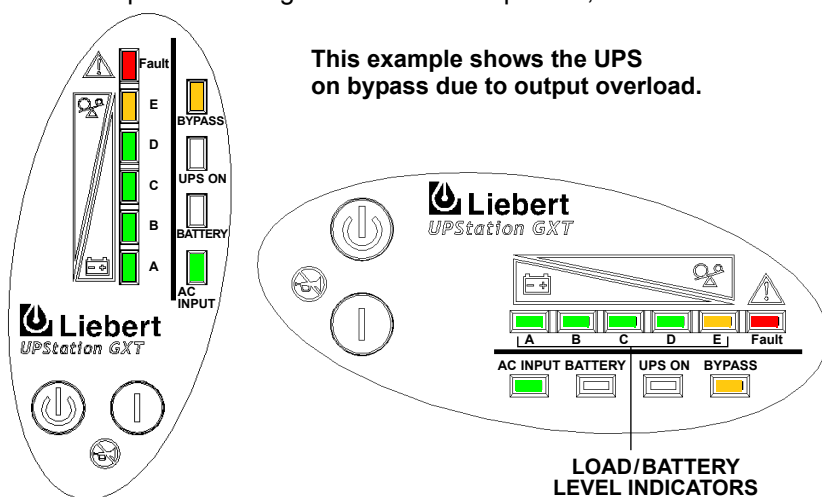

LED status	Diagnosis/Audible alarm
All LEDs	On bypass due to output overload; beep every half-second
A LED	On bypass due to overtemperature condition; beep every 4 sec.
B LED	On bypass due to DC bus overvoltage; beep every 4 sec.
C LED	On bypass due to control power supply failure; beep every 4 sec.
D LED	On bypass due to PFC failure; beep every 4 sec.
E LED	On bypass due to inverter failure; beep every 4 sec.
A&C LEDs	UPS failed battery test; long beep every minute
C&E LEDs	UPS shutdown due to command from communication port (SNMP); no beep
Battery LED Flashing	Internal Battery source not available (continuous horn). Check battery connection, completely power down and reboot UPS.
AC LED Flashing	Line-to-neutral reversal in the AC input power supply or a loss of proper grounding; continuous horn and UPS will not start.
Bypass LED Flashing	Utility power voltage or frequency is out of tolerance; bypass is unavailable.

Under fault conditions, the Fault indicators will be illuminated indefinitely while battery charger is operational, or for a maximum of 5 minutes while battery charger is not operational.

If a problem persists, consult your local dealer, Liebert representative or contact the Liebert Worldwide Support Group. Please have the UPS model number and serial number available at the time of your inquiry.

Troubleshooting Guide

Problem	Cause	Solution
UPS fails to start when the ON button is pressed.	UPS is short circuited or overloaded.	Ensure UPS is OFF. Disconnect all loads and ensure nothing is lodged in output receptacles. Ensure loads are not defective or shorted internally.
Battery indicator LED is illuminated.	UPS not plugged in.	UPS is operating from battery mode, make certain UPS is securely plugged into the wall receptacle.
	UPS input protection fuse has blown/opened.	UPS is operating from battery mode. Save data and close applications. Replace UPS input fuse, then restart UPS.
	Utility voltage out of UPS input range.	UPS is operating from battery mode. Save data and close applications. Ensure utility supply voltage is within acceptable limits for UPS.
UPS has reduced battery time.	Batteries are not fully charged.	Keep UPS plugged in continuously at least 24 hours to recharge batteries.
	UPS is overloaded.	Check load level display and reduce the load on the UPS.
	Batteries may not be able to hold a full charge due to age.	Replace batteries. Contact your local dealer, Liebert representative or the Liebert Worldwide Support Group for replacement battery kit.

Troubleshooting Guide (Continued)

Problem	Cause	Solution
Fault and Bypass indicator LEDs and all load level LEDs are illuminated.	UPS overloaded or load equipment is faulty.	Check load level display and remove non-essential loads. Recalculate the load and reduce number of loads connected to UPS. Check load equipment for faults.
Fault and Bypass indicator LEDs and diagnostic LED A are illuminated.	UPS internal fan has a problem or UPS shutdown due to temperature condition. Load is on bypass power.	Ensure UPS is not overloaded, ventilation openings not blocked, or room ambient temperature is not excessive. Wait 30 minutes to allow UPS to cool, then restart UPS. If UPS does not restart, contact your local dealer, Liebert representative or the Liebert Worldwide Support Group.
Fault and Bypass indicator LEDs and diagnostic LED B are illuminated.	UPS internal DC bus overvoltage.	UPS requires service. Contact your local dealer, Liebert representative or the Liebert Worldwide Support Group.
Fault and Bypass indicator LEDs and diagnostic LED C are illuminated.	UPS control power supply fault.	UPS requires service. Contact your local dealer, Liebert representative or the Liebert Worldwide Support Group.
Fault and Bypass indicator LEDs and diagnostic LED D are illuminated.	UPS PFC (Power Factor Correction Circuit) fault.	UPS requires service. Contact your local dealer, Liebert representative or the Liebert Worldwide Support Group.
Fault and Bypass indicator LEDs and diagnostic LED E are illuminated.	UPS inverter fault.	UPS requires service. Contact your local dealer, Liebert Representative or the Liebert Worldwide Support Group.
Fault indicator LED and diagnostic LED A and C are illuminated.	UPS failed the battery test.	Replace batteries. Contact your local dealer, Liebert representative or the Liebert Worldwide Support Group.

Troubleshooting Guide (Continued)

Problem	Cause	Solution
<p>Fault and Bypass indicator LEDs and diagnostic LED C and E are illuminated.</p>	<p>UPS shutdown due to a command from the communications port(s).</p>	<p>Your UPS has received a signal or command from the attached computer. If this was inadvertent, ensure the communication cable used is correct for your system. For assistance, contact your local dealer, Liebert representative or the Liebert Worldwide Support Group.</p>
<p>AC LED is flashing.</p>	<p>UPS detected a line-to-neutral reversal or a loss of proper grounding; continuous horn and UPS will not start. This is active only when power is first applied to the input. Once the UPS is running, the AC LED will not start flashing, even if the input wiring is changed.</p>	<p>Contact a qualified electrician to verify site wiring.</p>
<p>Battery LED is flashing.</p>	<p>Battery source is not available; continuous horn.</p>	<p>Check battery connections, completely power down and restart UPS. NOTE: If the battery circuit opens while the UPS is running, it will be detected when the next battery test is performed.</p>
<p>Bypass LED is flashing.</p>	<p>Bypass voltage is present, but is disabled for use because the voltage or frequency is outside acceptable limits.</p>	<p>The AC input powers the PFC input and serves as the bypass source. If the AC is present but the voltage or frequency exceeds the acceptable range for safe operation with a load, the bypass will be disabled and this LED will flash, indicating that the bypass is unavailable.</p>

Alarm Conditions	
Condition	Alarm
Battery Mode (utility failure)	One short beep every 10 seconds; more than 2 minutes of run time remaining
Low Battery	Two short beeps every 5 seconds; less than 2 minutes of run time remaining
Output Overload (bypass)	One short beep every half second
Overtemperature (bypass)	A one-second beep every 4 seconds
DC Bus Overvoltage (bypass)	A one-second beep every 4 seconds
Control Power Supply Failure (bypass)	A one-second beep every 4 seconds
PFC Failure (bypass)	A one-second beep every 4 seconds
Inverter Failure	A one-second beep every 4 seconds
Battery Test Failure	A 2-second beep every minute

SPECIFICATIONS

Model Number	GXT2-2700RT208
Model Rating	2700VA/1890W
DIMENSIONS: in. (mm)	
Unit - W x D x H: in. (mm)	3.5 x 24.2 x 17 (87 x 618 x 430)
Shipping - W x D x H: in. (mm)	10.5 x 27.2 x 23 (268 x 692 x 585)
WEIGHT lbs (kg)	
Unit: lbs (kg)	75.2 (34.1)
Shipping: lbs (kg)	84.9 (38.5)
INPUT AC PARAMETERS	
Voltage Range (typical)	208 VAC nominal; variable based on output load
100% - 90% loading	176 VAC/280 VAC
90% - 70% loading	159 VAC/280 VAC
70% - 30% loading	139 VAC/280 VAC
30% - 0% loading	119 VAC/280 VAC
Frequency	40 - 70 Hz; Auto Sensing
Input Power Cord	10 ft. attached w/ NEMA L6-20 plug
OUTPUT AC PARAMETERS	
Output Receptacles	(2) NEMA L6-15R (1) NEMA L6-20R
Voltage	200/208/220/230/240 (user configurable) VAC; ±3%
Frequency	50 Hz or 60 Hz
Waveform	Sinewave
Main Mode Overload	200% for 8 cycles; 130% for 10 seconds with transfer to bypass
BATTERY PARAMETERS	
Type	Valve-regulated, nonspillable, flame retardant, lead acid
Qty x V x Rating	6 x 12V x 9.0 AH
Battery Mfg/Part #	Panasonic/ UP-VW1245P1 Yuasa/ REW 45-12 FR
Back-Up Time	See Battery Run Times charts
Recharge Time	5 Hours to 95% capacity after full discharge into 100% load (Internal Batteries Only)
ENVIRONMENTAL	
Operating Temp	+32°F to +104°F (0°C to +40°C)
Storage Temp	+5°F to +122°F (-15°C to +50°C)
Relative Humidity	0% to 95%, non-condensing
Operating Elevation	Up to 10,000 ft. (3000 m) at 104°F (40°C) without derating
Storage Elevation	50,000 ft. (15,000 m) maximum
Audible Noise	<55 dBA, at 1 meter from the rear <50 dBA, at 1 meter from the front or sides
AGENCY	
Safety	UL 1778, c-UL Listed (Suitable for computer room applications)
RFI/EMI	FCC Part 15, Subpart B, Class A
Surge Immunity	IEEE 587 Category A & B
Transportation	ISTA Procedure 1A

BATTERY CABINET SPECIFICATIONS

Model Number	GXT2-72VBATT
Used w/ UPS Model	GXT2-2700RT208
DIMENSIONS in (mm)	
Unit - W x D x H in. (mm)	3.5 x 24.2 x 17 (87 x 618 x 430)
Shipping - W x D x H in. (mm)	10.5 x 27.2 x 23 (268 x 692 x 585)
WEIGHT lbs (kg)	
Unit: lbs (kg)	93.6 (42.5)
Shipping: lbs (kg)	102.5 (46.5)
BATTERY PARAMETERS	
Type	Valve-regulated, nonspillable, flame retardant, lead acid
Qty x V x Rating	2 x 6 x 12V x 9.0 AH
Battery Mfg/Part #	Panasonic/UP-VW1245P1 Yuasa/REW 45-12 FR
Back-Up Time	See Battery Run Times charts
ENVIRONMENTAL	
Operating Temp	+32°F to +104°F (0°C to +40°C)
Storage Temp	+5°F to +122°F (-15°C to +50°C)
Relative Humidity	0% to 95%, non-condensing
Operating Elevation	Up to 10,000 ft. (3000 m) at 104°F (40°C) without derating
Storage Elevation	50,000 ft. (15,000 m) maximum
AGENCY	
Safety	UL 1778, c-UL Listed (Suitable for computer room applications)
RFI/EMI	FCC Part 15, Subpart B, Class A
Transportation	ISTA Procedure 1A

BATTERY RUN TIMES

	Load %	Estimated Time
Internal Battery (minutes)	10%	91
	20%	46
	30%	30
	40%	21
	50%	16
	60%	11
	70%	9
	80%	8
	90%	7
	100%	5
Internal Battery + 1 External Battery Cabinet (minutes)	10%	364
	20%	184
	30%	120
	40%	84
	50%	64
	60%	44
	70%	36
	80%	32
	90%	28
	100%	20
Internal Battery + 2 External Battery Cabinets (minutes)	10%	728
	20%	368
	30%	240
	40%	168
	50%	128
	60%	88
	70%	72
	80%	64
	90%	56
	100%	40
Internal Battery + 3 External Battery Cabinets (minutes)	10%	1092
	20%	552
	30%	360
	40%	252
	50%	192
	60%	132
	70%	108
	80%	96
	90%	84
	100%	60
Internal Battery + 4 External Battery Cabinets (minutes)	10%	1456
	20%	736
	30%	480
	40%	336
	50%	256
	60%	176
	70%	144
	80%	128
	90%	112
	100%	80

Note: Approximate discharge times are in minutes and at 77°F (25°C) with a 100% resistive load.

PRODUCT WARRANTY REGISTRATION

To register for warranty protection:

- Visit the **Quick Links** section of our Web site at:
<http://www.liebert.com>
- Click on **Product Warranty Registration** and fill in the form.

If you have any questions, please contact us at:

US: 800-222-5877

Outside the US: 614-841-6755

upstech@liebert.com

POWER AVAILABILITY

UPStation GXT 2U™

USER MANUAL

The Company Behind the Products

With over a million installations around the globe, Liebert is the world leader in computer protection systems. Since its founding in 1965, Liebert has developed a complete range of support and protection systems for sensitive electronics:

- Environmental systems—close-control air conditioning from 1 to 60 tons
- Power conditioning and UPS with power ranges from 300 VA to more than 1000 kVA
- Integrated systems that provide both environmental and power protection in a single, flexible package
- Monitoring and control—from systems of any size or location, on-site or remote
- Service and support through more than 100 service centers around the world and a 24/7 Customer Response Center

While every precaution has been taken to ensure the accuracy and completeness of this literature, Liebert Corporation assumes no responsibility and disclaims all liability for damages resulting from use of this information or for any errors or omissions.

© 2003 Liebert Corporation

All rights reserved throughout the world. Specifications subject to change without notice.

® Liebert and the Liebert logo are registered trademarks of Liebert Corporation. All names referred to are trademarks or registered trademarks of their respective owners.

SL-23154 (6/03) Rev. 1

Technical Support/Service

Web Site

www.liebert.com

Monitoring

800-222-5877

monitoring@liebert.com

Outside the US: 614-841-6755

Single-Phase UPS

800-222-5877

upstech@liebert.com

Outside the US: 614-841-6755

Three-Phase UPS

800-543-2378

powertech@liebert.com

Environmental Systems

800-543-2778

Outside the United States

614-888-0246

Locations

United States

1050 Dearborn Drive

P.O. Box 29186

Columbus, OH 43229

Italy

Via Leonardo Da Vinci 8

Zona Industriale Tognana

35028 Piove Di Sacco (PD)

+39 049 9719 111

Fax: +39 049 5841 257

Asia

23F, Allied Kajima Bldg.

138 Gloucester Road

Wanchai

Hong Kong

+852 2 572 2201

Fax: +852 2 831 0114



EMERSON
Network Power

Free Manuals Download Website

<http://myh66.com>

<http://usermanuals.us>

<http://www.somanuals.com>

<http://www.4manuals.cc>

<http://www.manual-lib.com>

<http://www.404manual.com>

<http://www.luxmanual.com>

<http://aubethermostatmanual.com>

Golf course search by state

<http://golfingnear.com>

Email search by domain

<http://emailbydomain.com>

Auto manuals search

<http://auto.somanuals.com>

TV manuals search

<http://tv.somanuals.com>