

## UPStation GXT™

6 & 10 kVA  
230V

### USER MANUAL English



## IMPORTANT SAFETY INSTRUCTIONS

1. **SAVE THESE INSTRUCTIONS. THIS MANUAL CONTAINS IMPORTANT SAFETY INSTRUCTIONS.** Read all safety and operating instructions before operating the Uninterruptible Power System (UPS). Adhere to all warnings on the unit and in this manual. Follow all operating and user instructions. This equipment can be operated by individuals without previous training.
2. This product is designed for Commercial/Industrial use only. It is not intended for use with life support and other designated "critical" devices. Maximum load must not exceed that shown on the UPS rating label. The UPS is designed for data processing equipment. If uncertain, consult your dealer. See Limited Warranty.
3. This UPS is designed for use on a properly earthed (grounded), 208-240 VAC, 50Hz or 60Hz supply, for installation by qualified personnel. A qualified electrician must review and approve customer supplied wiring, circuit breakers, intended loads, and verify correct input, output and earth connections to ensure compliance with technical standards and local electrical codes of practice. Installation instructions and warning notices only for use by qualified personnel are located after the UPS operator instructions in this manual.

**WARNING:** This UPS should not be supplied from electrical power systems of the "IT" (Impédance à Terre) type. (IEC 364-ELECTRICAL INSTALLATION OF BUILDINGS)

4. **ELECTROMAGNETIC COMPATIBILITY-** This UPS complies with the requirements of the EMC Directive 89/336/EEC and the published technical standards. Continued compliance requires installation in accordance with these instructions and the use of manufacturer approved accessories only.  
**WARNING:** This is a CLASS A – Uninterruptible Power System Product. In a domestic environment, this may cause radio interference, in which case the user may be required to take additional measures.
5. Operate the UPS in an indoor environment only in an ambient temperature range of 0°C to +40°C (32°F to +104°F). Install it in a clean environment, free from moisture, flammable liquids, gasses, or corrosive substances.
6. This UPS contains no user serviceable parts. The UPS ON/OFF pushbuttons do not electrically isolate internal parts. Under no circumstances attempt to gain access internally, due to the risk of electric shock or burn. Do not continue to use the UPS if the front panel indications are not in accordance with these operating instructions, or the UPS performance alters in use. Refer all faults to your dealer.
7. Only trained engineers authorised by Liebert should perform troubleshooting. To replace batteries, refer all servicing to qualified service personnel. **PROPER DISPOSAL OF BATTERIES IS REQUIRED. REFER TO YOUR LOCAL LAWS AND REGULATIONS FOR DISPOSAL REQUIREMENTS.**
8. Never block or insert any object into the ventilation holes or other openings.
9. **DO NOT CONNECT** equipment that could overload the UPS or demand DC current from the UPS, for example: electric drills, vacuum cleaners, laser printers, hairdryers or any appliance using half wave rectification.

10. Storing magnetic media on top of the UPS may result in data loss or corruption.
11. Turn the UPS off and isolate the UPS before cleaning. Use only a soft cloth, never liquid or aerosol cleaners.

## GLOSSARY OF SYMBOLS

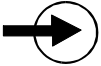

Indicates AC Input



Indicates AC Output



Indicates Caution: Note the accompanying instruction



Indicates the position of a fuse



Requests the user to consult the manual for additional information

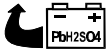

Indicates that the unit contains a valve regulated lead acid battery

## INTRODUCTION AND SYSTEM DESCRIPTION

Congratulations on your choice of the UPStation GXT™ Uninterruptible Power System (UPS). It provides conditioned power to microcomputers and other sensitive electronic equipment.

Upon generation, AC power is clean and stable. However, during transmission and distribution it may be subject to voltage sags, spikes, or complete power failure, which may interrupt computer operations, cause data loss, or even damage equipment. The UPStation GXT protects equipment from these disturbances.

The UPStation GXT is a compact, “on-line” UPS. An “on-line” UPS continuously conditions and regulates its output voltage, whether the mains power is present or not. It supplies connected equipment with clean sinewave power. Sensitive electronic equipment operates best from sinewave power. The GXT 6000/10000T-230X models have an additional output isolation transformer.

For ease of use, the UPStation GXT contains a light emitting diode (LED) display to indicate either “load percentage” or “battery capacity” depending upon the mode of operation. It also provides self-diagnostics, a combination On/Alarm Silence/Manual Battery Test button, a combination Off/Bypass button, and two levels of alarms when the unit is operating on battery.

The UPStation GXT has an interface port for communications between the UPS and a LAN server or other computer system. This port provides detailed operating information including voltages, currents, and alarm status to the host system when used in conjunction with the SiteNet® 2 software. SiteNet® 2 software can also remotely control UPS operation.

## MAJOR COMPONENTS

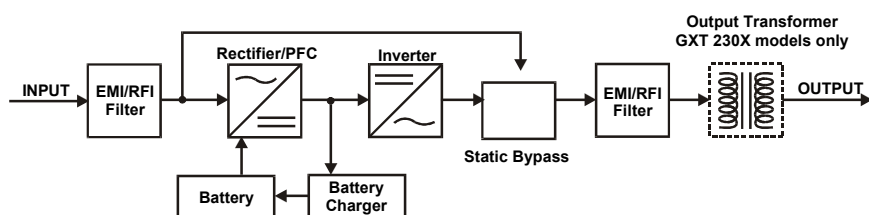

## TRANSIENT VOLTAGE SURGE SUPPRESSION (TVSS) AND EMI/RFI FILTERS

These UPS components provide surge protection, and filter both electromagnetic interference (EMI) and radio frequency interference (RFI). They minimize any surges or interference present in the mains line and keep the sensitive equipment protected.

## **RECTIFIER/POWER FACTOR CORRECTION (PFC) CIRCUIT**

In normal operation, the rectifier/power factor correction (PFC) circuit converts mains AC power to regulated DC power for use by the inverter, while ensuring that the wave shape of the input current used by the UPS is near ideal. Extracting this sinewave input current achieves two objectives: the mains power is used as efficiently as possible by the UPS, and the amount of distortion reflected on the mains is reduced. This results in cleaner power being available to other devices in the building not being protected by the UPStation GXT.

## **INVERTER**

In normal operation, the inverter utilises the DC output of the power factor correction circuit and “inverts” it into precise, regulated sinewave AC power. Upon a mains power failure, the inverter receives its required energy from the battery through the rectifier / PFC. In both modes of the operation, the UPS inverter is on-line and continuously generating clean, precise, regulated AC output power.

## **BATTERY CHARGER**

The battery charger utilises energy from the Rectifier / PFC and precisely regulates it to continuously “float” charge the battery system. The battery system charges whenever the UPStation GXT is connected to mains power.

## **BATTERY**

The UPStation GXT employs valve regulated, non-spillable, lead acid batteries. At typical room temperatures and with the UPS float charging, the battery system will last many years. Optional external battery cabinets are available to provide extended run times.

## **STATIC BYPASS**

The UPStation GXT provides an alternate path for mains power to the connected load, in the unlikely event of a UPS malfunction. Should the UPS have an overload, over temperature, or UPS failure condition, the UPS automatically transfers the connected load to **BYPASS** providing the bypass voltage is within specification. **BYPASS** operation is indicated by an alarm and an illuminated **BYPASS** LED (other LED's may be illuminated to indicate the diagnosed problem). To manually transfer the connected load from the inverter to **BYPASS** power, press the output OFF button once.

**NOTE:** The **BYPASS** power path does NOT protect the connected equipment from disturbances on the mains supply and its range of operation is limited to +/- 15% of the nominal input supply voltage.

## **AUTO RE-START**

Upon restoration of the mains AC power after a mains power outage and complete battery discharge, the UPS will automatically restart and supply power to the critical load and the battery charger automatically recharges the battery.

## CONTROLS AND INDICATORS

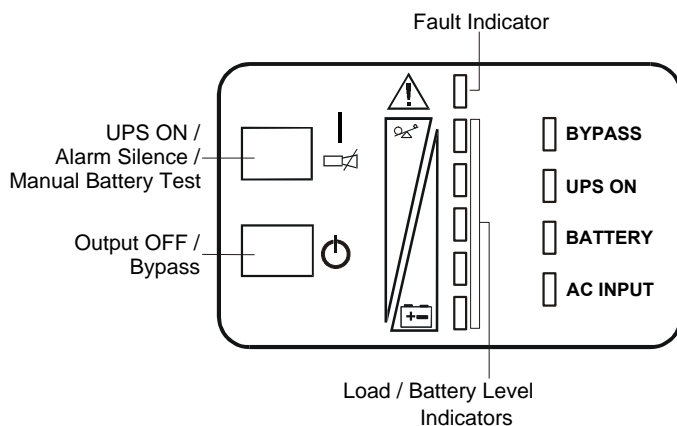

### **Fault Indicator (Red)**

The Fault indicator is illuminated if the UPS has detected a problem. Also, one or more of the load/battery level indicators may be illuminated (refer to Troubleshooting Guide).

### **BYPASS Indicator (Amber)**

The BYPASS indicator is illuminated when the UPS is operating from BYPASS power. An alarm will sound indicating the UPS detected a problem, or manually set to BYPASS.

### **UPS ON Indicator (Green)**

The UPS On indicator is illuminated when the UPS inverter is operating and supplying power to your connected loads.

### **Battery Indicator (Amber)**

The Battery indicator is illuminated when the UPS is operating from the battery system.

### **AC Input Indicator (Green)**

The AC Input indicator is illuminated when mains power is available and within the input specification.

### **Load/Battery Level Indicators (4 Green, 1 Amber)**

The Load/Battery Level indicators have dual functions. During NORMAL mode operation LED indicators display the approximate electrical load placed upon the UPS; and during battery mode operation LED indicators display approximate battery capacity.

The UPStation GXT is equipped with automatic and remote battery test features. The automatic test occurs every 14 days if a manual battery test has not been performed or if mains has not been interrupted (14 day timer resets if unit goes to battery). Should the battery fail this test, the fault indicator along with the A and C diagnostic LEDs will illuminate and an alarm will sound (refer to Troubleshooting Guide). The remote test feature functions with either SiteNet® 2 or SiteNet® SNMP Manager software and can remotely initiate the battery test.

### **UPS ON/Alarm Silence/Manual Battery Test Button**

This button controls output power to connected load(s) and has three functions: UPS ON, Alarm Silence, and Manual Battery Test. To start the UPS, while in the BYPASS mode, press this button until the command is acknowledged by a beep from the audible alarm. This will provide conditioned and protected power into the output terminal block.

To silence alarms, press this button for at least one half second while alarm conditions are present. After the alarm is silenced, the UPStation GXT will reactivate the alarm system to alert of additional problems.

NOTE: The low battery and BYPASS reminder alarms cannot be silenced.

BATTERY TESTING- To initiate a manual battery test, press this button for at least one half second while operating in normal UPS mode power and no alarm conditions are present. If the bottom two LED's do not illuminate during a Battery Test, allow the UPS to recharge the batteries for 24 hours. After 24 hours, retest the batteries. If the batteries have been re-tested and the bottom two LED's still do not illuminate, contact your dealer or Global Services for a battery replacement.

### **OUTPUT OFF/BYPASS Button**

This button controls output power to connected load(s) and has dual functions: OUTPUT OFF and Bypass.

CAUTION: Pressing this button once during normal operation will cause the load to be transferred to BYPASS power. Pressing this button a second time within 4 seconds will result in loss of power to the output and connected loads. Perform all necessary shutdown procedures on connected loads before pressing this button twice.

# GXT 6 & 10 kVA

## Component Diagram

230 & 230X Models Shown

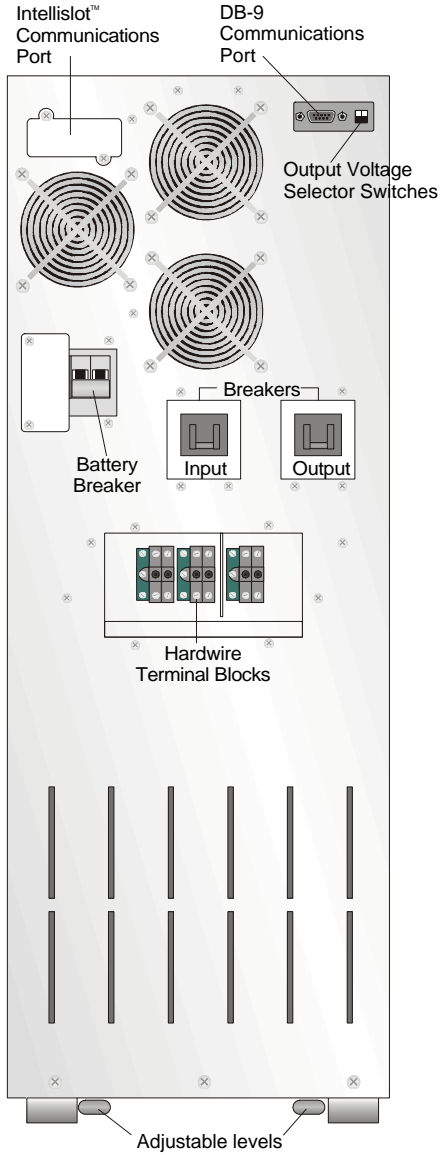
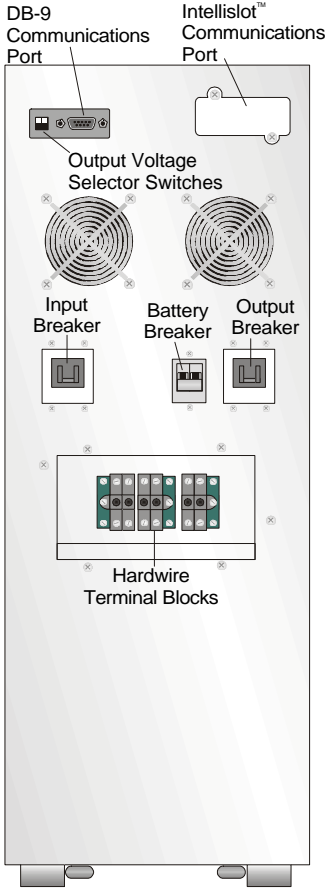



## OPERATING MODES

### NORMAL MODE OPERATION- UPS mode

During normal operation, mains power provides energy to the UPS. The filters, the power factor correction circuit and the inverter process this power to provide computer grade power to connected loads. The UPS maintains the batteries in a fully charged state.

The four green LED's indicate an approximate level of load in 25% increments. If the UPS becomes loaded beyond full rating, the fifth (amber) LED indicator will illuminate and sound an alarm.

The display template indicates the percentage of load on the UPS output.

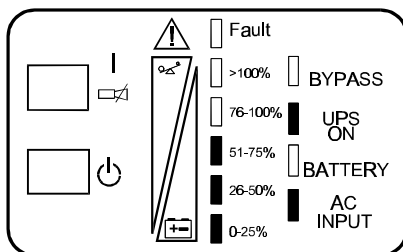

*Normal Mode Operation at  
51-75% loading*

### BATTERY MODE OPERATION

Battery mode occurs in event of an extreme input voltage condition or complete mains failure. The battery system supplies power through the DC-DC converter to the inverter to generate power for the connected load.

During battery mode an alarm sounds every 10 seconds. This will change to 2 beeps every 5 seconds when battery runs low (approximately 2 minutes remaining). The AC Input LED will extinguish, and the Battery LED will illuminate to warn that a mains problem has occurred. Each load/battery level indicator represents a 20% capacity level.

As capacity decreases, fewer indicators remain illuminated. Refer to the Troubleshooting Guide.

To increase this time, turn off non-essential pieces of equipment (such as idle computers and monitors) or add an optional external battery cabinet.

**CAUTION:** Turning off the UPS while in battery mode will result in loss of output power.

Once mains power is restored, the UPS resumes normal operation. At this time, the Battery Charger begins recharging the battery.

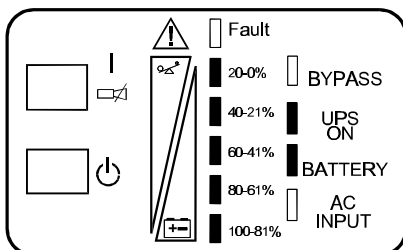

*Battery Mode Operation at  
81-100% battery capacity*

## BYPASS MODE OPERATION

During BYPASS operation, mains power provides energy to your load and maintains the batteries in a fully charged state.

The four green LED's indicate an approximate level of load in 25% increments. If the BYPASS becomes loaded beyond full rating, the fifth (amber) LED indicator will illuminate and sound an alarm.

The display template indicates the percentage of load on the output.

**CAUTION:** The BYPASS power path does not protect the connected equipment from disturbances on the mains supply.

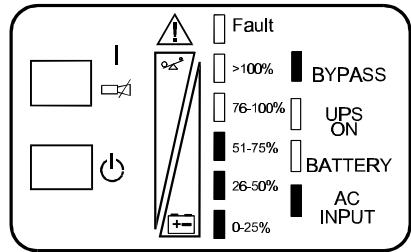

*Bypass Mode Operation at  
51-75% loading*

## STARTING THE UPS

1. Ensure the load equipment is turned off, and all loads are properly connected to the UPS output.
2. Check that the mains wall isolator is ON. Turn On (Close) the Battery circuit breaker, the Input and Output circuit breakers in that order. The UPS will now automatically start up and default to BYPASS mode once the UPS is connected to an active AC mains supply and the Battery and Input circuit breakers are closed. At the end of the startup sequence the BYPASS LED should be lit.
3. TO PROTECT YOUR LOAD YOU MUST NOW PRESS THE UPS ON/ALARM /BATTERY TEST BUTTON TO GO TO UPS MODE
4. Press the UPS ON/ALARM /BATTERY TEST button for at least one half second until you hear the audible alarm give a “Beep” to signal acceptance of the command. After a delay of about 10 seconds, the BYPASS LED will extinguish and the UPS ON LED should light. The UPS will then initiate a self-test and a battery test. When these tests are complete, the UPS is ready for NORMAL UPS operation. Connected load equipment may now be started.

## POWERING DOWN THE UPS

1. Check to ensure that all connected load equipment is shutdown. Press the **OUTPUT OFF/ BYPASS** button until a “Beep” is heard. Release the button and then immediately press for at least one second. The **UPS ON** LED will extinguish and the **BYPASS** LED will light for a short period then extinguish. When the **AC input** LED and the bottom LED of the BATTERY/LOAD array are lit and the **UPS ON** and **BYPASS** LED's extinguish, the output is powered down.
2. If necessary to isolate the UPS, set the input, output and battery breakers on the rear of the UPS to OFF position. Finally for complete isolation turn OFF the wall mounted mains isolator.

## SWITCHING FROM OUTPUT OFF TO UPS or UPS to BYPASS to OFF

1. If the UPS is in OUTPUT OFF condition, with all rear mounted breakers in the ON position, and the **AC input** LED and the bottom LED of the BATTERY/LOAD array lit. To go to UPS mode, press the **UPS ON/ALARM /BATTERY TEST** button until a "Beep" is heard. The UPS will then go through its start-up routine ending up after approximately 10 seconds with the **UPS** LED lit.
2. If the UPS is operating in UPS mode and there is a need to go to BYPASS mode, press the **OUTPUT OFF/BYPASS** button until a beep is heard. The **UPS ON** LED will extinguish and the **BYPASS** LED will be lit.

**WARNING:** In BYPASS mode your connected load is NOT PROTECTED from mains disturbances.

If you are in BYPASS mode and want to set the OUTPUT to OFF. Press the **OUTPUT OFF/ BYPASS** button for a least 1 second, twice, within a 4 second time interval. There is no audible "Beep" on this action.

## OPERATION IN BATTERY MODE

If in the absence of the mains power it is essential for the UPS output to be made available for a critical operation, then the following procedure should be followed.

1. To start the UPS in BATTERY mode, press the **UPS ON/ALARM /BATTERY TEST** button for at least one half second until you hear the audible alarm gives a double "Beep" to signal acceptance of the command. After a short delay, the **BATTERY** LED should light. The UPS will then initiate a self-test and approximately 10 seconds after these tests are completed, the **UPS ON** LED will light. Connected load equipment may now be started.

PLEASE NOTE- duration of output power will be limited to remaining battery capacity shown by the battery LED's.

2. To power down the UPS. Press the **OUTPUT OFF/ BYPASS** button until the audible alarm "Beeps". The UPS will now shutdown and all LED's extinguish.

## TROUBLESHOOTING

The information below indicates various symptoms a user may encounter in the event the UPSStation GXT develops a problem. Use this information to determine whether external factors cause the problem and how to remedy the situation.

1. The fault indicator will illuminate indicating the UPS detected a problem.
2. An alarm will sound, alerting that the UPS requires attention.
3. One or more additional load/battery level LED indicators will be illuminated to provide a diagnostic aid to the operator, as described below:

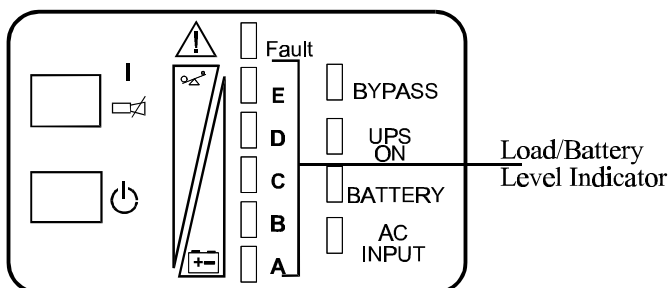

- All.** On bypass due to output overload (beep every half second)
- A.** On bypass due to over temperature condition (beep every 4 seconds)
- B.** On bypass due to DC bus over voltage (beep every 4 seconds)
- D.** On bypass due to PFC failure (beep every 4 seconds)
- E.** On bypass due to inverter failure (beep every 4 seconds)
- A&C.** UPS failed battery test (long beep every minute)
- C&E.** UPS shutdown due to command from communication port (SNMP); no beep

The fault indicators will be illuminated indefinitely while battery charger is operational, or for a maximum of 5 minutes while battery charger is not operational. If a problem persists consult your dealer, or contact Technical Support. World Wide Technical Support numbers are located at the end of this manual.

## AUDIBLE ALARM CONDITIONS

CONDITION	ALARM
Battery mode (utility failure)	One short beep every ten seconds
Low battery	Two short beeps every five seconds
Output overload (bypass)	One short beep every half second
Over temperature (bypass)	One second beep every four seconds
DC Bus over voltage (bypass)	One second beep every four seconds
PFC failure (bypass)	One second beep every four seconds
Inverter failure	One second beep every four seconds
Battery Test failure	Two second beep every minute

## TROUBLESHOOTING GUIDE

PROBLEM	CAUSE	SOLUTION
UPS fails to start when on button is pressed	UPS is short circuited or overloaded	Ensure UPS is off. Disconnect all loads and ensure nothing is lodged in output terminal block. Ensure loads are not defective or shorted internally.
	Internal fuse is blown, indicating internal fault	Do not attempt to open or service the UPS. Contact your dealer or technical support.
	Breaker not closed or has tripped.	Close breaker or remove overload.
Battery indicator is illuminated	UPS input not connected	UPS is operating from battery mode, make certain UPS is securely connected to source.
	UPS input protection has opened	UPS is operating from battery mode. Save data and close applications. Replace UPS input fuse or reset input breaker, then restart UPS.
	Mains voltage out of UPS input range.	UPS is operating from battery mode. Save data and close applications. Ensure mains supply voltage is within acceptable limits for UPS.
UPS has reduced battery time	Batteries not fully charged	Apply input voltage for at least 24 hrs to recharge batteries.
	UPS is overloaded	Check load level display and reduce load level
	Batteries may not be able to hold a full charge due to age	Replace batteries. Contact your dealer or technical support.

## TROUBLESHOOTING GUIDE

PROBLEM	CAUSE	SOLUTION
Fault and Bypass indicators and all load level LED's are illuminated	UPS overloaded or load equipment is faulty	Check load level display and remove non-essential loads. Recalculate load VA and reduce number of loads connected to UPS. Check load equipment for faults.
Fault and Bypass indicators and diagnostic LED A are illuminated	UPS internal fan has a problem or UPS shutdown due to temperature condition. Load is on bypass power.	Press Alarm silence button. Once the temperature is reduced, the UPS will restart and transfer the connected equipment to inverter power automatically.
Fault and Bypass indicators and diagnostic LED B are illuminated	UPS internal DC bus over voltage	UPS requires service. Contact your dealer or technical support.
Fault and Bypass indicators and diagnostic LED D are illuminated	UPS PFC fault.	UPS requires service. Contact your dealer or technical support.
Fault and Bypass indicators and diagnostic LED E are illuminated	UPS inverter fault.	UPS requires service. Contact your dealer or technical support.
Fault indicators and diagnostic LED A & C are illuminated	UPS failed the battery test.	Replace batteries. Contact your dealer or technical support.
Fault indicators and diagnostic LED C & E are illuminated	UPS shutdown due to a command from the communications port(s)	Your UPS has received a signal or command from the attached computer. If this was inadvertent, ensure the communication cable used is correct for your system. For assistance, contact your dealer or technical support.

## UPS MONITORING

The UPStation GXT UPS has the capability of being monitored with stand alone computers, network workstations, network servers, or UNIX hosts via the DB-9 socket located on the rear of the UPS.

This capability is used in applications requiring the UPS to provide status and power monitoring information to the computer system. For example, during a mains power failure, the information can be used by the computer's operating system or application program to automatically save information in buffers, to close files, and shut down operations prior to battery capacity depletion.

Monitoring of the UPS via a computer is as easy as downloading SiteNet® MultiLink™ free from our web site ([www.liebert.com](http://www.liebert.com)). A MultiLink cable may also be built by following instructions provided on our web page. You may also purchase a Liebert SiteNet® 1 shutdown kit (sold separately). Consult your local Liebert representative to determine the correct software kit for your application. The kit includes shutdown software and a special purpose cable.

## UPS INTELLIGENT COMMUNICATIONS

The UPStation GXT UPS has the capability to communicate intelligently with stand alone computers, network workstations, network servers, or UNIX hosts via the DB-9 socket located at the rear of the UPS. By purchasing the optional Liebert SiteNet® 2 software package (sold separately), intelligent communications allows the following capabilities:

- Quantitative monitoring of mains and UPS power
- Quantitative monitoring of internal UPS parameters
- Periodic tests of battery quality and replacement notification
- Timed and delayed shutdown of the UPS
- Logging of power disturbances and anomalies

Consult your local Liebert sales representative for more information about SiteNet® 2 software.

## UPS INTELLISLOT™ COMMUNICATIONS

The UPStation GXT UPS contains an Intellislot™ communications port for the optional internal MultiPort 4 card, AS400 card, or Ethernet SNMP card. Optional SiteNet® SNMP Manager software is available to allow communication through several network management systems to be used in conjunction with the Intellislot SNMP card. Contact your local Liebert representative, dealer, or reseller.



## MAINTENANCE

The UPStation GXT UPS requires very little maintenance. The batteries are valve regulated, non-spillable, lead acid, and should be kept charged to obtain their designed life. The UPS continuously charges the batteries when connected to the mains supply.

When storing the UPS for any length of time, it is recommended to apply power to the UPS for at least 24 hours every four to six months to ensure full recharge of the batteries. In no case should the unit be stored in excess of nine months without recharge. Periodically, examine the vents on the front and rear of the cabinet, and remove any obstructions from the surface of the vents.

# INSTALLATION INSTRUCTIONS

These instructions are for use by competent personnel only.

## INSTALLATION CONSIDERATIONS

Detailed instructions to help you install the UPS are provided in the following pages; however, you should give some consideration to the proposed environment in which the UPS is to be installed, and carry out some preparatory work.

## INSPECTION

Before you install the UPS, give it a thorough visual examination to ensure it has not been subjected to shipping damage. If it is not in perfect condition, you should advise both the shipper and the supplier immediately. **DO NOT ATTEMPT TO INSTALL A DAMAGED UPS.**

Check the UPS rating plate that the UPS is suitable for operation on your mains voltage and load voltage requirements.

Before disposing of the UPS packaging, check that you have removed to a safe place the user manual and any other items shipped with the unit to be used in its installation.

### CAUTION:

GXT6000 UPS weighs up to 139kg - GXT10000 UPS weighs up to 244kg. Use adequate handling aids when moving or installing the UPS. The UPS is fitted with castor wheels for easy movement. Take care when the UPS is removed from its packing and being wheeled across an uneven floor without the stabilisers fitted, that it does not tip over. See notes on adjustment of levelling feet and stabilisers.

## LOCATION

Locate the UPStation GXT indoors in a controlled environment, where it cannot be accidentally disconnected. Locate it in an area with unrestricted airflow, away from water, flammable liquids, gases, corrosives, or conductive contaminants.

Give consideration to the airflow requirements- (see below)- and allow at least 150mm (6inches) free space around the UPS, with a minimum of 300mm (12inches) at the back to enable easy operator access to the rear panel mounted input/output/battery circuit breakers.

Air vents are located at the front and the rear of the UPS. Do not position the UPS in an enclosed space where airflow is restricted.

Optional battery cabinets are designed to be placed on either side of the UPS.

Electrical maintenance/servicing requires access to both sides of the UPS, provide the necessary free space or use a flexible wiring system to allow the UPS to be pulled forward.

Maintain an ambient temperature range of 0 - +40° centigrade (32-104° F)

NOTE- UPS operation in temperatures above 25°C (77°F) reduces battery life.

AIRFLOW		DISSIPATION		OUTPUT RATING		INPUT CURRENT Amps max
Cfm	m <sup>3</sup> h	Watts	K Btu/hr	VA	Watts	Including mains variation/battery charge
130	221	504	1.7	6000	4200	GXT6000 = 33 amps
270	459	840	2.8	10000	7000	GXT10000= 54 amps

### ELECTRICAL INSTALLATION CONSIDERATIONS

This UPS must be installed by competent electrical personnel and wired in accordance with local/national electrical codes.

The following information is provided for your guidance.

#### WARNING

HIGH EARTH LEAKAGE CURRENT- EARTH CONNECTION IS ESSENTIAL BEFORE CONNECTING THE MAINS SUPPLY. Earth in accordance with local electrical codes.

#### CAUTION

This UPS is fitted with EMC suppression filters. Earth leakage exceeds 35mA. Transient and steady state earth leakage currents, which may occur when starting the UPS, should be taken into account when selecting instantaneous RCCB or RCCD devices. Note also that the earth leakage currents of the load will be carried by this RCCB or RCCD.

#### WARNING

This UPS does not incorporate automatic backfeed protection. A warning label must be fitted to all primary power isolators stating: ISOLATE UNINTERRUPTIBLE POWER SYSTEM BEFORE WORKING ON THIS CIRCUIT.

On start-up, the UPS will take a half cycle inrush current of up to 3 times the rated current. This must be taken into account when selecting the overload protection device at the input mains supply distribution point. To avoid random tripping on start-up, we recommend that the input mains supply be protected with an MCB capable of withstanding this initial inrush. An MCB specified as being "TYPE 4" (British standard) or "CURVE D" (IEC standard) is suitable for this purpose.

The mains input supply cable must be connected to the UPS via a wall mounted double pole circuit breaker, rated to carry the current in table 1 and be capable of breaking the maximum prospective short circuit current of this branch circuit. The breaker is to be mounted within two metres of the UPS and be readily accessible to the operator.

## **ELECTRICAL CONNECTIONS**

The UPS is supplied with an input/output/ battery terminal block assembly on the rear of the UPS within a cable box. (see outline drawing) The cable box can be removed to enable knockouts to be removed or new holes drilled, to secure the cables.

The cable sizes and distribution methods used during installation are subject to local/ national electrical codes of practice , and therefore are not detailed here. However, table 1 gives details of the input current and the UPS rating plate gives details of the output current according to output voltage selected.

The terminals will accept wire sizes up to the values below:

$$\text{GXT6000} = 10 \text{ mm}^2$$

$$\text{GXT10000} = 16\text{mm}^2$$

### Connecting the UPS Power cables

Power cables connect to screw terminals on a terminal block that is located behind the rear mounted cable box (see figure). The cables enter the UPS through a Gland Plate attached to the rear of the UPS. The Gland Plate must first be removed and drilled to suit the glands or bushes for the cables used. Ensure that the glands are sized so that they hold the cables securely.

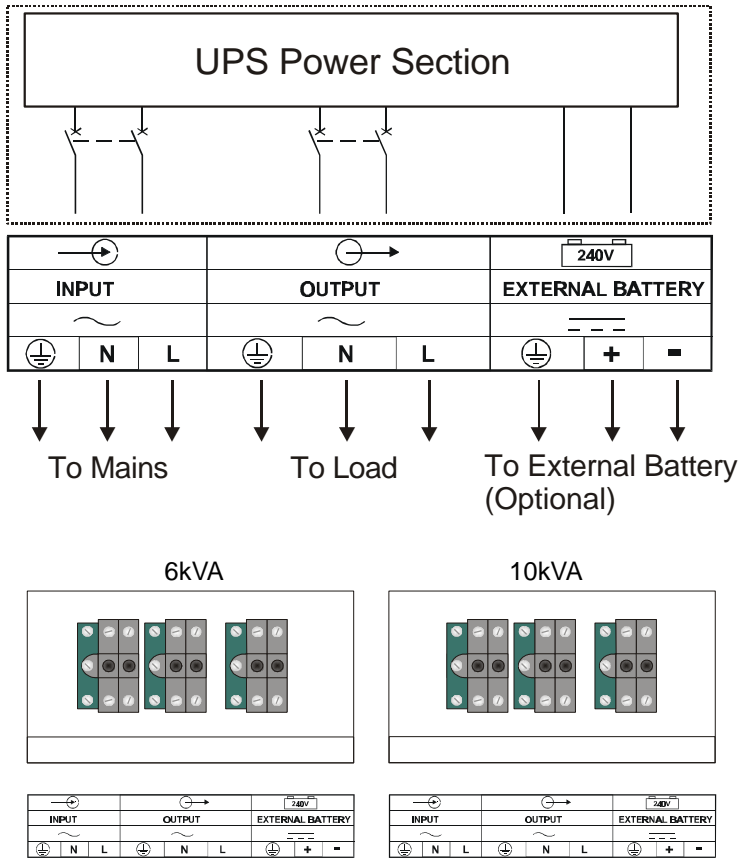

**GXT 6 / 10 kVA Connection Diagram**

### Connection of optional remote battery cabinets.

Full installation instructions are provided with these cabinets. Safety/EMC certification limits the use of these terminals to Liebert supplied options.

### Output connections GXT 6000/10000-X models only

Models whose part number ends with an "X" are fitted with an isolating output transformer. The output of this transformer is referenced to earth at the neutral terminal, remove this earth-neutral link when required by local electrical codes.

## Stabilisers/Levelling Feet

When the UPS is located in its final position before or after wiring, it is necessary to fit stabiliser brackets and, if necessary, adjust the levelling feet. If the UPS is wired using a rigid wiring system, then movement of the UPS must be prevented by winding down the 4 levelling feet under the UPS as shown below. For UPS wired with flexible cables, this is optional. Note- Access to the levelling feet is obstructed by the stabiliser brackets, on the GXT10000 models.

Adjust the levelling feet as necessary using a 12mm open ended spanner/wrench. **DO NOT LOOSEN THE LARGER NUT ABOVE, AS THIS FIXES THE LEVELLING FEET TO THE CHASSIS.**

Attach the stabilising brackets as follows.

GXT6000 models:

1. Using a Phillips-head screwdriver, remove the screws(4) from each of the bottom corners of the side panels.
2. Attach the stabilising brackets to each corner using screws just removed.

GXT10000 models :

1. Using a Phillips-head screwdriver, remove the three inner-most screws at the base of both side panels.
2. Attach the stabilisers fixing with the screws just removed.

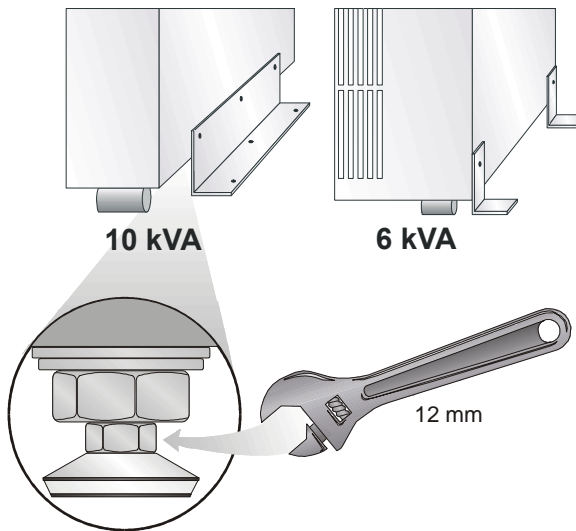

**Levelling Feet Adjustment Diagram**

## COMMUNICATIONS INTERFACE PORT

The UPStation GXT UPS contains a standard DB-9 socket located on the rear of the UPS unit. Several signals are provided on this port and are assigned as follows:

PIN	ASSIGNMENT DESCRIPTION
1	Low Battery (open collector)
2	UPS TxD (typical RS-232 levels)
3	UPS RxD (typical RS-232 levels)
4	Remote Shutdown (5-12V); battery operation
5	Common
6	Remote Shutdown (short to pin 5) UPS mode (all modes) of operation
7	Low Battery (open emitter)
8	Mains Fail (open emitter)
9	Mains Fail (open collector)

**PIN ASSIGNMENT**

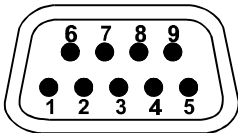

**COLLECTOR TO EMITTER\***

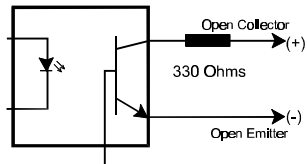

\*Maximum voltage and current on pins 1,7,8,9 is 80V DC; 10.0 mA.

**CAUTION:** TO MAINTAIN SAFETY (SELV) BARRIERS AND FOR ELECTROMAGNETIC COMPATABILITY, SIGNAL CABLES SHOULD BE SEGREGATED AND RUN SEPARATE FROM ALL OTHER POWER CABLES, BY 25mm WHERE APPLICABLE.

### UPS Remote shutdown option.

Shorting pins 5 and 6 on the DB9 connector will shutdown the UPS output in any mode of operation. Removing the short circuit, the UPS will automatically auto-restart.

Where there is a requirement for a remote shutdown of the UPS to meet fire or other local safety codes, it is necessary to interrupt, at the same time with the same pushbutton, all mains input supplies to the UPS. The pushbutton that provides the UPS remote shutdown must be of the stay-down type ( Latching) to keep a short circuit on pins 5 and 6 until mechanically unlatched by hand.

Note ; The wiring for remote stop contacts pins 5 and 6 of the DB9 connector are defined as SELV . When connecting to a stop button interfacing with other mains emergency stop circuits, keep wiring segregated from other power wiring.

## FERRITE BEAD INSTALLATION

When using either of the options below, to reduce the risk of radio interference, fit the ferrite assemblies supplied with the UPS as follows:

### Serial Communications

Attach the smaller enclosed ferrite bead clamp to the communication cable as shown in the drawing using the following directions:

- Open the ferrite bead.
- Place the communication cable inside the ferrite bead groove.
- Position the ferrite beads as close as possible to the end of the cable that connects to the DB9 connector of the UPS.
- Close the ferrite bead so that the ferrite bead's case snaps closed with the cable routed inside the ferrite bead's case.

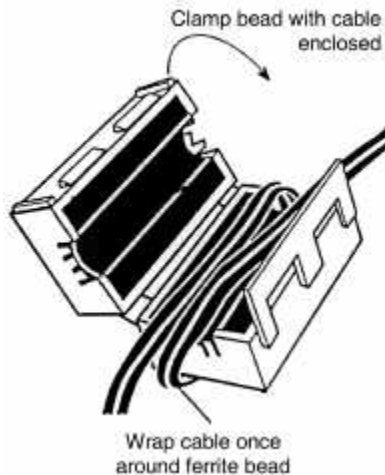

### SNMP Installation ( When fitted)

Attach the larger enclosed ferrite bead clamp to the network cable as shown in the drawing using the following directions:

- Open the ferrite bead.
- Place the network cable inside the ferrite bead groove.
- Wrap the cable once around the bead.
- Position the ferrite cable as close as possible to the end of the cable that connects to the UPS.

Close the ferrite bead so that the ferrite bead's case snaps closed with the cable routed inside the ferrite bead's case.



## COMMISSIONING THE UPS

### Output Voltage Selector Switches

The Output Voltage Selector Switches, located on the rear of the UPS, are designed to allow selecting or changing the desired output voltage to match the mains. The settings to choose from are 208, 220, 230, and 240 VAC output.

230 & 230X Units	
208 V	↑↑ - both switches up
220 V	↑↓ - first switch up, second down
230 V	↓↓ - both switches down (Factory Default)
240 V	↓↑ - first switch down, second up

**NOTE:** NEVER change the switch settings while UPS is on and powering connected loads.

**NOTE:** Setting output voltage to 208 VAC will cause UPS unit to be derated to 90% of the VA and Watt rating listed in specification section.

1. Adjust the output voltage switch settings to the desired value.
2. Follow the instructions for Powering up the UPS referenced earlier in this manual. Sequence through the operating modes, using the front panel pushbuttons, in accordance with operating instructions to check functionality of the UPS.
3. Set the UPS to UPS mode. Check on the output terminals of the UPS, for the correct output voltage for the voltage rating of the intended loads.
4. Check operation of the remote shutdown circuit (If fitted).
5. In UPS mode, power up customers load and check that it is within the UPS rating by observing the front panel LED's
6. In UPS mode, press the UPS ON/ALARM /BATTERY TEST pushbutton to carry out battery test and ensure the load can be supported. Note- Full battery capacity will not be available until a battery recharge cycle has been completed.

The UPS is now ready for service In case of problems refer to the fault finding section or call your local distributor for advice.

## Battery Run Times

Load %	6kVA	6kVA + (1) GXT240VBATT	6kVA + (2) GXT240VBATT
10%	69	250	360
20%	58	197	301
25%	52	174	278
30%	48	155	248
40%	33	117	190
50%	23	88	140
60%	17	73	110
70%	14	60	94
75%	12	54	85
80%	11	50	77
90%	9	42	68
100%	8	37	59

Load %	10kVA	10kVA + (1) GXT240VLRT	10kVA + (2) GXT240VLRT
10%	71	480	900
20%	60	390	730
25%	55	345	655
30%	49	305	585
40%	39	230	450
50%	29	164	335
60%	23	129	265
70%	20	105	225
75%	18	93	205
80%	17	85	190
90%	14	70	155
100%	12	60	125

**Note:** All run times are in minutes, assume fully charged batteries, and are typical at 25°C (77°F) with resistive loads.

## SPECIFICATIONS

<b>MODEL NUMBER</b>	GXT6000T-230	GXT10000T-230
<b>MODEL RATING VA/W (max)</b>	6000 / 4200	10000 / 7000
<b>DIMENSIONS: mm (in)</b>		
Unit	260 x 555 x 803	340 x 650 x 960
W x D x H	(10.5 x 22.0 x 31.5)	(13.5 x 25.5 x 38.0)
Shipping	400 x 850 x 1065	510 x 840 x 1235
W x D x H	(16.0 x 33.5 x 42.0)	(20.0 x 33.0 x 48.5)
<b>WEIGHT: kg (lbs)</b>		
Unit	99 (218)	187 (412)
Shipping	130 (288)	227 (500)
<b>Input/Output Connections</b>	Hardwire terminal block	
<b>INPUT AC PARAMETERS</b>		
Voltage Range (typical)	230 VAC nominal; variable based upon output load	
100% - 90% Loading	186 VAC to 280 VAC; ±5.0 VAC	
90% - 70% Loading	159 VAC to 280 VAC; ±5.0 VAC	
70% - 30% Loading	139 VAC to 280 VAC; ±5.0 VAC	
30% - 0% Loading	119 VAC to 280 VAC; ±5.0 VAC	
Frequency	46.6 – 52.4 Hz or 57.1 - 62.9 Hz; auto sensing	
<b>OUTPUT AC PARAMETERS</b>		
Voltage	208/220/230/240 VAC (switch selectable); ±3%	
Frequency	50 Hz or 60 Hz; auto sensing	
Waveform	Sinewave	
Main Mode Overload	200% for 8 cycles; 130% for 10 seconds with transfer to bypass	
<b>BATTERY PARAMETERS</b>		
Type	Valve-regulated, nonspillable, lead acid	
Qty. x Voltage x Rating	20 x 12V x 7.0 Ah	40 x 12V x 7.0 Ah
Back-up Time	7 min. minimum	10 min. minimum
Recharge Time (Internal Batteries Only)	7 hours to 95% capacity after full discharge into 100% load	
<b>ENVIROMENTAL</b>		
Operating Temperature	0° C to +40° C (+32° F to +104° F)	
Storage Temperature	-15° C to +50° C (+5° F to +122° F)	
Relative Humidity	0% to 95%, non-condensing	
Operating Elevation	Up to 3000 m (10,000 ft.) at 40° C without derating	
Storage Elevation	15,000 m (50,000 ft.) maximum	
Audible Noise	<55 dB "A" at 1 metre	<65 dB "A" at 1 metre
<b>AGENCY</b>		
Safety	EN50091-1-1; TUV/GS Listed; CE Low Voltage Directive	
EMI/EMC	EN50091-2, Class A; CE EMC Directive	
Immunity	IEC 801-2, Level 4 / IEC 801-3, Level 3 / IEC 801-4, Level 4 / IEC801-5,Level 3	

<b>SPECIFICATIONS</b>		
<b>MODEL NUMBER</b>	GXT6000T-230X	GXT10000T-230X
<b>MODEL RATING VA/W (max)</b>	6000 / 4200	10000 / 7000
<b>DIMENSIONS: mm (in)</b>		
Unit	260 x 555 x 803	340 x 650 x 960
W x D x H	(10.5 x 22.0 x 31.5)	(13.5 x 25.5 x 38.0)
Shipping	400 x 850 x 1065	510 x 840 x 1235
W x D x H	(16.0 x 33.5 x 42.0)	(20.0 x 33.0 x 48.5)
<b>WEIGHT: kg (lbs)</b>		
Unit	139 (306)	244 (538)
Shipping	170 (374)	284 (626)
<b>Input/Output Connections</b>	Hardwire terminal block	
<b>INPUT AC PARAMETERS</b>		
Voltage Range (typical)	230 VAC nominal; variable based upon output load	
100% - 90% Loading	186 VAC to 280 VAC; ±5.0 VAC	
90% - 70% Loading	159 VAC to 280 VAC; ±5.0 VAC	
70% - 30% Loading	139 VAC to 280 VAC; ±5.0 VAC	
30% - 0% Loading	119 VAC to 280 VAC; ±5.0 VAC	
Frequency	46.6 – 52.4 Hz or 57.1 - 62.9 Hz; auto sensing	
<b>OUTPUT AC PARAMETERS</b>		
Voltage	208/220/230/240 VAC (switch selectable); ±7%	
Frequency	50 Hz or 60 Hz; auto sensing	
Waveform	Sinewave	
Main Mode Overload	200% for 8 cycles; 130% for 10 seconds with transfer to bypass	
<b>BATTERY PARAMETERS</b>		
Type	Valve-regulated, nonspillable, lead acid	
Qty. x Voltage x Rating	20 x 12V x 7.0 Ah	40 x 12V x 7.0 Ah
Back-up Time	7 min. minimum	10 min. minimum
Recharge Time (Internal Batteries Only)	7 hours to 95% capacity after full discharge into 100% load	
<b>ENVIROMENTAL</b>		
Operating Temperature	0° C to +40° C (+32° F to +104° F)	
Storage Temperature	-15° C to +50° C (+5° F to +122° F)	
Relative Humidity	0% to 95%, non-condensing	
Operating Elevation	Up to 3000 m (10,000 ft.) at 40° C without derating	
Storage Elevation	15,000 m (50,000 ft.) maximum	
Audible Noise	<55 dB "A" at 1 metre	<65 dB "A" at 1 metre
<b>AGENCY</b>		
Safety	EN50091-1-1; TUV/GS Listed; CE Low Voltage Directive	
EMI/EMC	EN50091-2, Class A; CE EMC Directive	
Immunity	IEC 801-2, Level 4 / IEC 801-3, Level 3 / IEC 801-4, Level 4 / IEC801-5,Level 3	

## LIMITED WARRANTY

Liebert Corporation extends the following LIMITED WARRANTY to the purchaser and to its customer (collectively referred to as the "Purchaser"): the enclosed Uninterruptible Power System (UPS) and components are free from defects in materials and workmanship under normal use, service, and maintenance FOR A PERIOD OF TWO YEARS FROM THE DATE OF ORIGINAL PURCHASE from Liebert or the Liebert dealer or retailer. THE FOREGOING WARRANTY IS THE ONLY WARRANTY GIVEN AND NO OTHER WARRANTY IS PROVIDED, EXPRESS OR IMPLIED, INCLUDING WITHOUT LIMITATION, MERCHANTABILITY OR FITNESS FOR A PARTICULAR PURPOSE. Certain aspects of disclaimers are not applicable to consumer products acquired by individuals and used for personal, family, or household purposes (as distinguished from industrial or other purposes). Local laws may not allow limitations on how long an implied warranty lasts, so the above limitation may not apply to you. This warranty gives you specific legal rights, and you may have other rights which vary according to local law.

Certain repairs or services are the responsibility of the Purchaser and the Purchaser is expected to pay for them. This warranty does not extend either to products with removed or altered serial numbers or to any losses or damages due to act of God or source external to the product, misuse, accident, abuse, neglect, negligence, unauthorised modification, alteration, or repair, use beyond rated capacity, or improper installation, maintenance, application or use, including, without limitation, use in a manner contrary to the accompanying instructions or applicable codes. **WARNING:** Warranty is void if the battery is allowed to discharge below the minimum battery cut-off point. The battery must be recharged every four (4) to six (6) months when not in use.

If the UPS fails to conform with the above warranty within the two year warranty period, Liebert will repair or replace the UPS, at Liebert's option. Repairs or replacements are warranted for the remainder of the original warranty period. Purchaser, to make a warranty claim, should call to obtain a Returned Goods Authorisation number and shipping instructions. Return transportation costs to Liebert are the responsibility of the Purchaser.

### "LIFE SUPPORT" APPLICATIONS

Due to the diversity of applications and considerations to be applied in each case, Liebert does not recommend or knowingly sells its products for such use.

The responsibility for risk assessment and management in applications where the malfunction or failure of the UPS could be reasonably expected to give rise to a risk of human life shall be the sole responsibility of the purchaser. Liebert accepts no liability for consequential harm in such applications.



## UPStation GXT™

6 & 10 kVA  
230 V

### Technical Support

---

Worldwide Support	+1 614 841-6755
Worldwide Fax Tech Support	+1 614 841-5471
U.K.	+44 1628 403 200
France	+33 1 4 360 26 19
Germany	+49 21669649340
Italy	+39 2 98250 1
Netherlands	+00 31 475 504050
E-mail	<a href="mailto:upstech@liebert.com">upstech@liebert.com</a>
Web site	<a href="http://www.liebert.com">http://www.liebert.com</a>

#### The Company Behind The Products

With more than 500,000 installations around the globe, Liebert is the world leader in computer protection systems. Since its founding in 1965, Liebert has developed a complete range of support and protection systems for sensitive electronics:

- Environmental systems: close-control air conditioning from 1.5 to 60 tons.
- Power conditioning and UPS with power ranges from 250 VA to more than 1000 kVA.
- Integrated systems that provide both environmental and power protection in a single, flexible package.
- Monitoring and control — on-site or remote — from systems of any size or location
- Service and support, through more than 100 service centres around the world, and a 24-hour Customer Response Centre.

While every precaution has been taken to ensure accuracy and completeness of this literature, Liebert Corporation assumes no responsibility, and disclaims all liability for damages resulting from use of this information or for any errors or omissions.

© 2001 Liebert Corporation All rights reserved throughout the world. Specifications subject to change without notice.

® Liebert and the Liebert logo are registered trademarks of Liebert Corporation. All names referred to are trademarks or registered trademarks of their respective owners.

SLI-23445 (3/01) Rev. 2

## Free Manuals Download Website

<http://myh66.com>

<http://usermanuals.us>

<http://www.somanuals.com>

<http://www.4manuals.cc>

<http://www.manual-lib.com>

<http://www.404manual.com>

<http://www.luxmanual.com>

<http://aubethermostatmanual.com>

Golf course search by state

<http://golfingnear.com>

Email search by domain

<http://emailbydomain.com>

Auto manuals search

<http://auto.somanuals.com>

TV manuals search

<http://tv.somanuals.com>