

PowerSure PSI™

USER MANUAL

1000 - 3000VA
230V



*Version française, : reportez-vous au CD du guide d'utilisateur Liebert.
Para español, consulte el CD del Manual del Usuario de Liebert.
Die deutsche Fassung finden Sie auf der CD des Liebert-Benutzerhandbuchs.
Per l'Italiano, consultare il CD contenente il Manuale dell'utente Liebert.*

TABLE OF CONTENTS

IMPORTANT SAFETY INSTRUCTIONS	1
1.0 GLOSSARY OF SYMBOLS	3
2.0 INTRODUCTION	4
3.0 MAJOR COMPONENTS	6
3.1 Transient Voltage Surge Suppression (TVSS) and EMI/RFI Filters.....	6
3.2 Relay	6
3.3 Automatic Voltage Regulator.....	7
3.4 Battery Charger	7
3.5 Battery	7
3.6 Inverter—1000/1440 Models Only.....	7
3.7 DC-to-DC Converter—2200/3000 Models Only	7
3.8 Bi-Directional Converter—2200/3000 Models Only.....	7
4.0 WHAT'S INCLUDED	8
5.0 INSTALLATION	9
5.1 Preparation	9
5.2 Tower UPS Installation	9
5.3 Rack-Mount UPS Conversion and Installation	10
5.4 External Battery Cabinet Installation	13
6.0 CONTROLS AND INDICATORS	14
6.1 ON/Alarm Silence/Battery Test Button	14
6.2 OFF Button.....	14
6.3 Voltage Programming Button	15
6.4 Load Level Indicators—4 green, 1 amber	15
6.5 Battery Level Indicators—5 green	15
6.6 AC Input Indicator—Green	15
6.7 Buck/Boost Indicator—Green	15
6.8 Battery Indicator—Green/Amber	15
6.9 Over Temp Indicator—Amber	16
6.10 Fault Indicator—Red	16
7.0 MODES OF OPERATION	17
7.1 Normal Mode	17
7.2 Buck/Boost Mode	17
7.3 Battery Mode	18
7.4 Battery Recharge Operation	18
8.0 COMMUNICATIONS	19
8.1 DB-9 Connector	19
8.2 Remote Shutdown Via the DB-9 Connector	19
8.2.1 Any Mode Shutdown—Via Pins 5 & 6.....	19
8.2.2 Battery Mode Shutdown—Via Pins 4 & 5.....	19
8.3 USB Interface Port.....	20
8.4 Data Line Protection Connectors.....	20
8.5 UPS Intelligent Communications	20

9.0	VOLTAGE PROGRAMMING PROCEDURE	21
10.0	MAINTENANCE	22
10.1	Cleaning the UPS	22
10.2	Maintaining Batteries	22
10.3	Battery Replacement	22
10.3.1	Internal Battery Replacement Procedure	23
11.0	TROUBLESHOOTING	24
12.0	SPECIFICATIONS	26

FIGURES

Figure 1	Front view of UPS	4
Figure 2	1000 and 1440VA PSI—rear view	5
Figure 3	2200 and 3000VA PSI—rear view	5
Figure 4	Line diagram of PowerSure PSI 1000VA & 1440VA	6
Figure 5	Line diagram of PowerSure PSI 2200VA & 3000VA	6
Figure 6	Support base for tower configuration.	9
Figure 7	Rack mount handles	10
Figure 8	Fixed rails with inner members extended.	10
Figure 9	Rack mounting rails and slide assemblies.	11
Figure 10	REPO switch connections	13
Figure 11	Load level indicators—4 green, 1 amber	15
Figure 12	Battery level indicators—5 green.	15
Figure 13	Normal mode operation with 26-50% load.	17
Figure 14	Buck/Boost mode operation with 51-75% load and 21-40% battery capacity	17
Figure 15	Battery mode at 61 – 80% battery capacity.	18
Figure 16	Low Battery mode	18
Figure 17	Load Level Indicators	21
Figure 18	Battery replacement procedure	23
Figure 19	Status indicators	24

TABLES

Table 1	DB-9 pin assignment	19
Table 2	Troubleshooting chart.	25
Table 3	UPS specifications.	26
Table 4	Battery cabinet specifications	27
Table 5	Battery run times	28

IMPORTANT SAFETY INSTRUCTIONS

SAVE THESE INSTRUCTIONS

This manual contains important safety instructions that should be followed during the installation and maintenance of the UPS and batteries. Please read this manual thoroughly before attempting to install or operate this UPS.



WARNING

SAFETY PRECAUTIONS

To prevent the risk of fire or electric shock, install the UPS in a temperature and humidity controlled room, free of conductive contaminants, moisture, flammable liquids, gases and corrosive substances.

Operate the UPS only from a properly grounded (earthed) 220-240 VAC, 50Hz or 60Hz AC supply.

To reduce the risk of electric shock, do not remove the cover—it has no user-serviceable parts inside except the internal battery pack. Some components are live, even when AC power is disconnected. For internal battery pack servicing, follow the instructions provided in **10.3 - Battery Replacement**. For other service, contact a qualified technician.



WARNING

ELECTRICAL PRECAUTIONS

- This UPS should not be supplied from electrical power systems of the IT (Impedance á Terre) type (IEC 364 - Electrical Installation of Buildings).
- The UPS must be earthed/grounded at all times during operation. Connect only to a mains supply socket outlet with an earth/ground connection.



CAUTION

Although your UPS has been designed and manufactured to ensure personal safety, improper use can result in electrical shock or fire. To ensure safety, please observe the following rules:

- Turn Off and unplug your UPS before cleaning. Do not use liquid or aerosol cleaners. A dry cloth is recommended to remove dust from the surface of your UPS.
- Do not install or operate your UPS in or near water.
- Do not place UPS on an unstable cart, stand or table.
- Do not place UPS under direct sunlight or close to heat emitting sources.
- Never block or insert any objects into the ventilation holes or other openings of the UPS. Keep all vents free of dust accumulation that could restrict air flow.
- Do not place UPS power cord in any area where it may get damaged by heavy objects.



WARNING

If your UPS demonstrates any of the following conditions, turn Off and unplug your UPS from the outlet and contact your local dealer, Liebert representative or Liebert Worldwide Support Group:

- The power cord or plug is damaged.
- Liquid has been spilled on the UPS.
- The circuit protector trips frequently.
- The UPS does not operate in accordance with the user manual.

CONDITIONS OF USE: The mains supply socket must be within 2m (6.5 ft.) of the UPS and be easily accessible.

Your UPS provides conditioned power to connected equipment. This product is designed for Commercial use only. It is not intended for use with life support and other designated “critical” devices. Maximum load must not exceed that shown on the UPS rating label. If uncertain, consult your local dealer, Liebert representative or the Liebert Worldwide Support Group.

The PSI 1000 VA, and 1440 VA models are not supplied with an input power cable for connection to the mains supply socket. Use the input mains supply power cable from your data processing equipment to connect the UPS to the mains supply.

For the 2200 VA and 3000VA models, use the supplied 16A-rated input mains supply cables. For UK supply systems, consult a qualified electrician to connect the lead supplied for the 2200 VA and 3000VA models to the mains supply.



CAUTION

The UPS and connected load total earth leakage current must not exceed 3.5mA. If the connected load earth leakage current is likely to exceed 2.5mA or you are unsure, then convert the input cable attachment to either a fixed wiring installation or an industrial plug/socket (e.g., CEE 17 connector). This alteration should be carried out by a competent electrical engineer who is conversant with local electrical codes and regulations.

When installing the UPS or making input and output connections, comply with relevant safety codes and standards (e.g. IEC60950, VDE0805, EN62040-1).

Placing magnetic storage media on top of the UPS may result in data corruption.

The equipment can be installed and operated by individuals without previous training.



CAUTION

DO NOT CONNECT equipment that could overload the UPS or demand half-wave rectification from the UPS, for example: electric drills, vacuum cleaners, laserjet/inkjet printers, hair dryers, overhead projectors.



CAUTION

Servicing of batteries should be performed or supervised by personnel knowledgeable of batteries and required precautions. Keep unauthorized personnel away from the batteries.

A battery can present a risk of electrical shock and high short-circuit current. The following precautions should be observed when working on batteries:

- Remove watches, rings, and other metal objects.
- Use tools with insulated handles.
- Do not dispose battery or batteries in a fire. The battery may explode.
- Do not open or mutilate the battery or batteries. Released electrolyte is harmful to skin and eyes. It is toxic.
- When replacing the battery, use same number and type of battery as the suitable recommended type of battery listed in **Table 3**.
- Handle, transport and recycle batteries in accordance with local regulations.

Electromagnetic Compatibility—The PowerSure™ PSI series complies with the requirements of the EMC Directive 89/336/EEC and the published technical standards. Continued compliance requires installation in accordance with these instructions and use of Liebert-approved accessories only.

Environmental—Operate the UPS in an indoor environment only in an ambient temperature range of 0°C to 40°C (32°F to 104°F). Install in a clean environment, free from conductive contaminants, moisture, flammable liquids, gases, or corrosive substances.

Provided are a Liebert MultiLink cable and a USB cable for connection to a computer. Do not use the Liebert MultiLink cable for other applications. Store in a safe place if not required at this time.

When using the communication features on this UPS, ensure the cabling connected to the DB-9 or UPS communications ports are kept separated from the power leads to the UPS input and output.

1.0 GLOSSARY OF SYMBOLS.



Risk of electrical shock



Indicates caution followed by important instructions



Requests the user to consult the manual

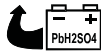

Indicates the unit contains a valve-regulated lead acid battery



Recycle



DC voltage



Equipment grounding conductor



Bonded to ground



AC voltage



ON/Alarm Silence/Battery Test



OFF



Voltage Programming Button

2.0 INTRODUCTION

Congratulations on your choice of the Liebert PowerSure™ PSI Uninterruptible Power Supply (UPS). It provides conditioned power to microcomputers and other sensitive electronic equipment.

Upon generation, AC power is clean and stable. However, during transmission it may be subject to voltage sags, spikes, or complete power failure which may interrupt computer operations, cause data loss, or even damage equipment. The PowerSure PSI protects equipment from these disturbances.

The PowerSure PSI comes in nominal power ratings of 1000, 1440, 2200, or 3000 VA. Refer to **12.0 - Specifications** for details.

The PowerSure PSI is a 2U, line-interactive UPS that may be installed in a rack or used in a tower configuration. A line-interactive UPS continuously conditions and regulates its output voltage, whether mains power is present or not. It supplies connected equipment with clean, sinewave power to simulate the power generated by the mains. Sensitive electronic equipment operates best from sinewave power.

For ease of use, the PowerSure PSI contains Status Indicators to display Load Level, Battery Level, Buck/Boost, Over Temperature and Battery. It also provides self-diagnostic tests, a combination ON/Alarm Silence/Battery Test button, an OFF button and Voltage Programming button.

The PowerSure PSI has USB, DB-9 (RS232/contact closure) and Intellislot interface ports for communications between the UPS and a LAN server or other computer systems. The DB-9 port provides detailed operating information including voltages, currents, and alarm status to the host system when used in conjunction with Liebert's MultiLink™ software. MultiLink software can also remotely control UPS operation. The USB port provides detailed operating information and alarm status to the host system when used in conjunction with the Liebert Human Interface Device (HID) and Microsoft Power Manager software.

Figure 1 Front view of UPS

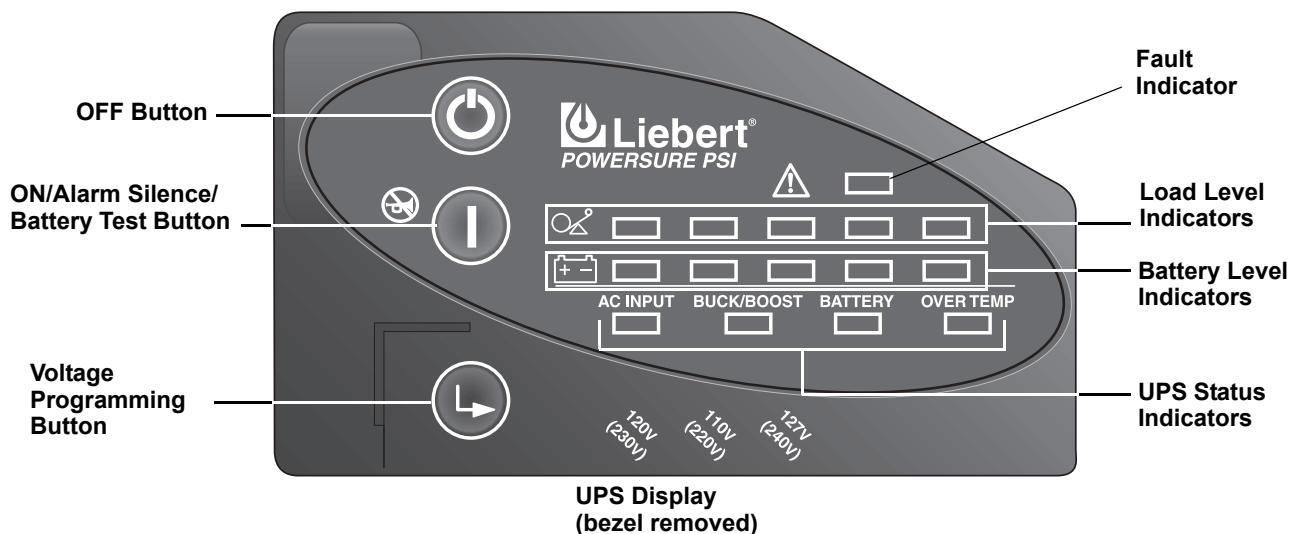
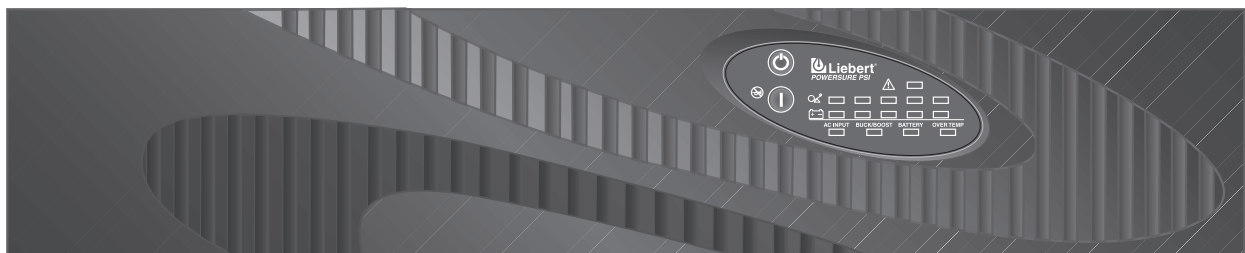

Figure 2 1000 and 1440VA PSI—rear view

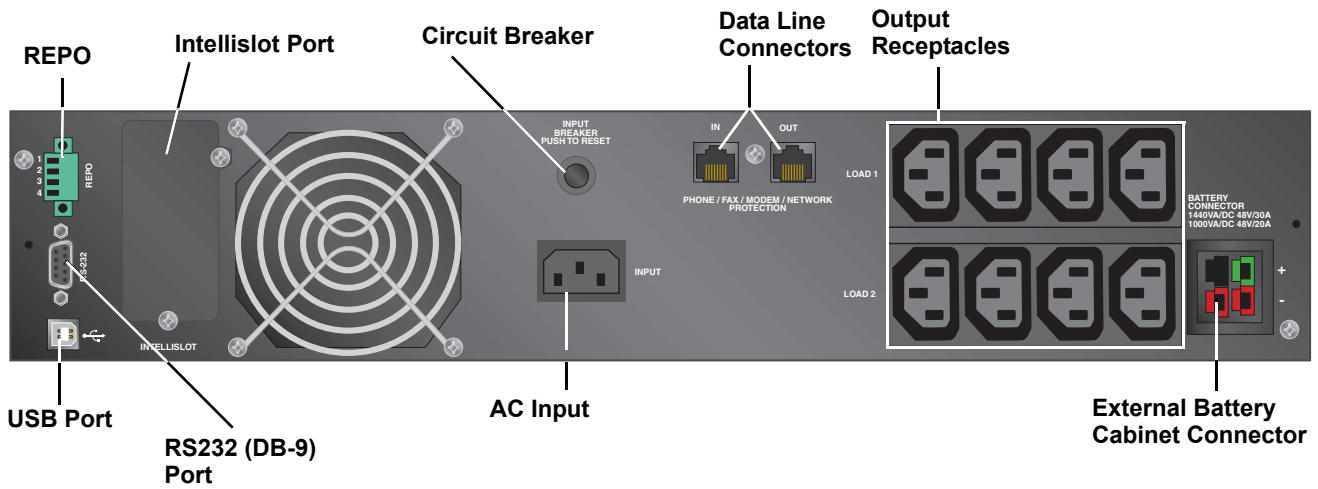
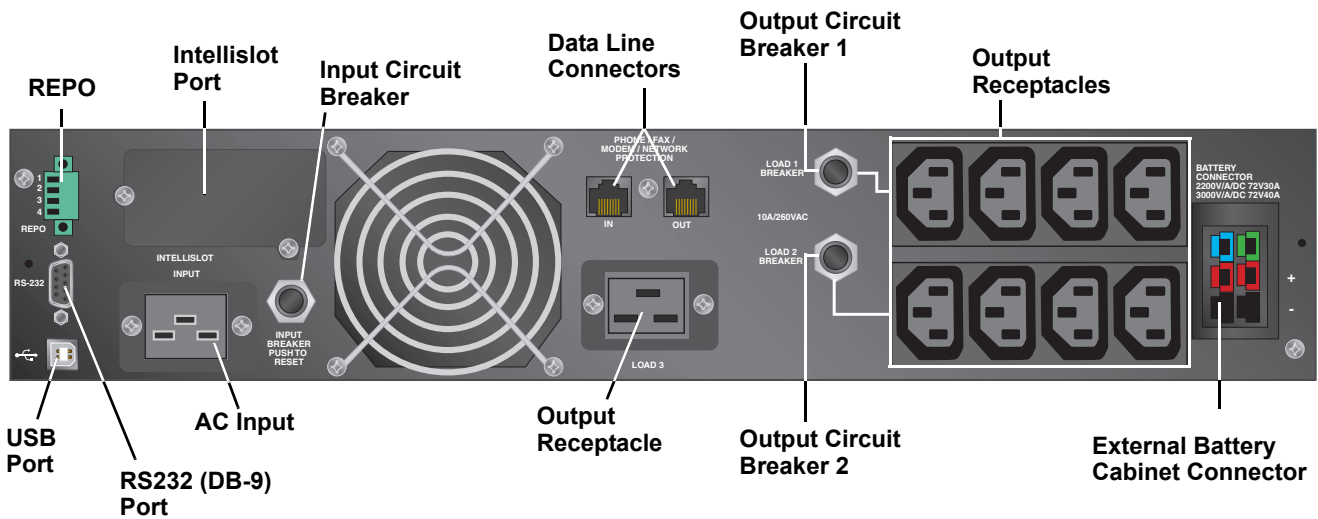

Figure 3 2200 and 3000VA PSI—rear view



3.0 MAJOR COMPONENTS

Figure 4 Line diagram of PowerSure PSI 1000VA & 1440VA

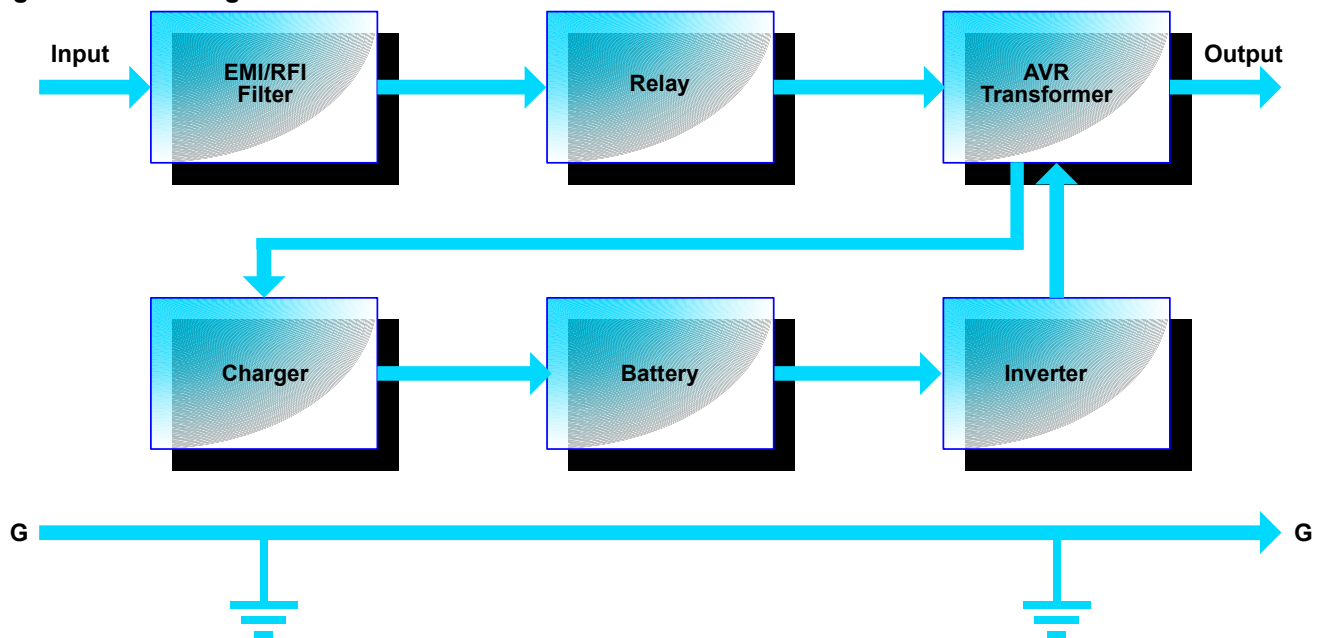
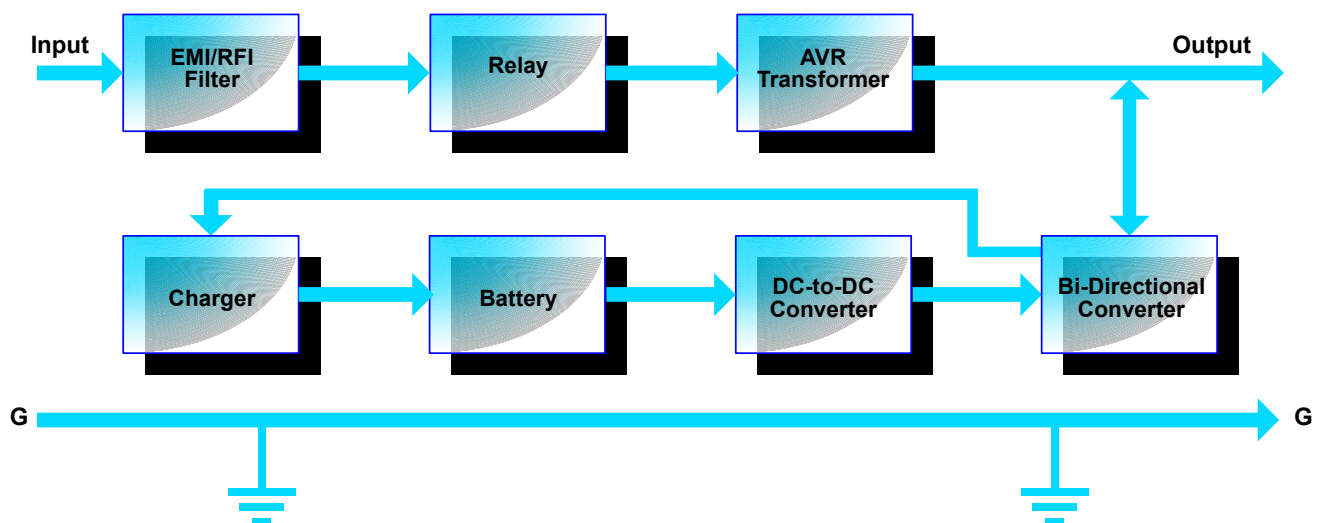

Figure 5 Line diagram of PowerSure PSI 2200VA & 3000VA



3.1 Transient Voltage Surge Suppression (TVSS) and EMI/RFI Filters

These UPS components provide surge protection and filter both electromagnetic interference (EMI) and radio frequency interference (RFI). They minimize surges or interference present in the mains line and keep the sensitive equipment protected.

3.2 Relay

In Normal mode the Relay passes mains AC power to the connected load. When input mains voltage or frequency is outside acceptable limits, the Relay activates and transfers the UPS to battery.

3.3 Automatic Voltage Regulator

The Automatic Voltage Regulator (AVR) protects connected equipment from power spikes, sags and other abnormalities by raising (boosting) or lowering (bucking) the output voltage as needed. This keeps the UPS output voltage within the connected equipment's tolerance and accommodates wide mains voltage fluctuations without utilizing the batteries.

3.4 Battery Charger

In Normal mode, the Battery Charger converts mains AC power into regulated DC power to float charge the battery. It is continuously charging the battery whenever the UPS is plugged into a power outlet and mains power is within acceptable limits - even if the UPS is turned Off.

3.5 Battery

The PowerSure PSI utilizes valve-regulated, nonspillable, lead acid batteries. To maintain battery design life, operate the UPS in an ambient temperature of 20°C to 25°C (68°F to 77°F). Optional external battery cabinets are available to extend battery run times.

3.6 Inverter—1000/1440 Models Only

In battery mode operation, the inverter utilizes the DC output of the battery and inverts it into precise, regulated, sinewave AC power.

3.7 DC-to-DC Converter—2200/3000 Models Only

The DC-to-DC Converter utilizes energy from the battery system and raises the DC voltage to the optimum operating voltage for the Bi-Directional Converter. This allows the Bi-Directional Converter to operate continuously at its optimum efficiency and voltage, thus increasing reliability.

3.8 Bi-Directional Converter—2200/3000 Models Only

In normal operation, the Bi-Directional Converter changes mains AC power into regulated DC power to "float charge" the battery system. This converter is continuously charging the battery whenever the UPS is plugged into a power outlet and mains power is within acceptable limits—even if the UPS is turned Off. When mains power fails, the Bi-Directional Converter draws energy from the battery through the DC-to-DC Converter and inverts it into a regulated sinewave supplying power to connected equipment.

4.0 WHAT'S INCLUDED

The PowerSure PSI is shipped with the following items:

- PowerSure PSI user manual
- MultiLink software CD
- MultiLink serial cable, 3m (10 ft)
- USB cable, 1.8m (6 ft)
- RJ-11 cord, 2.1m (7 ft)
- Rack mount handles
- Support base
- Fixed rails
- Mounting hardware (screws/washers)
- Front bezel
- Vertical display overlay
- Two (2) 10A output power cords, 2.0m (6.6 ft.)
- Input power cords, 2200 and 3000 VA models only

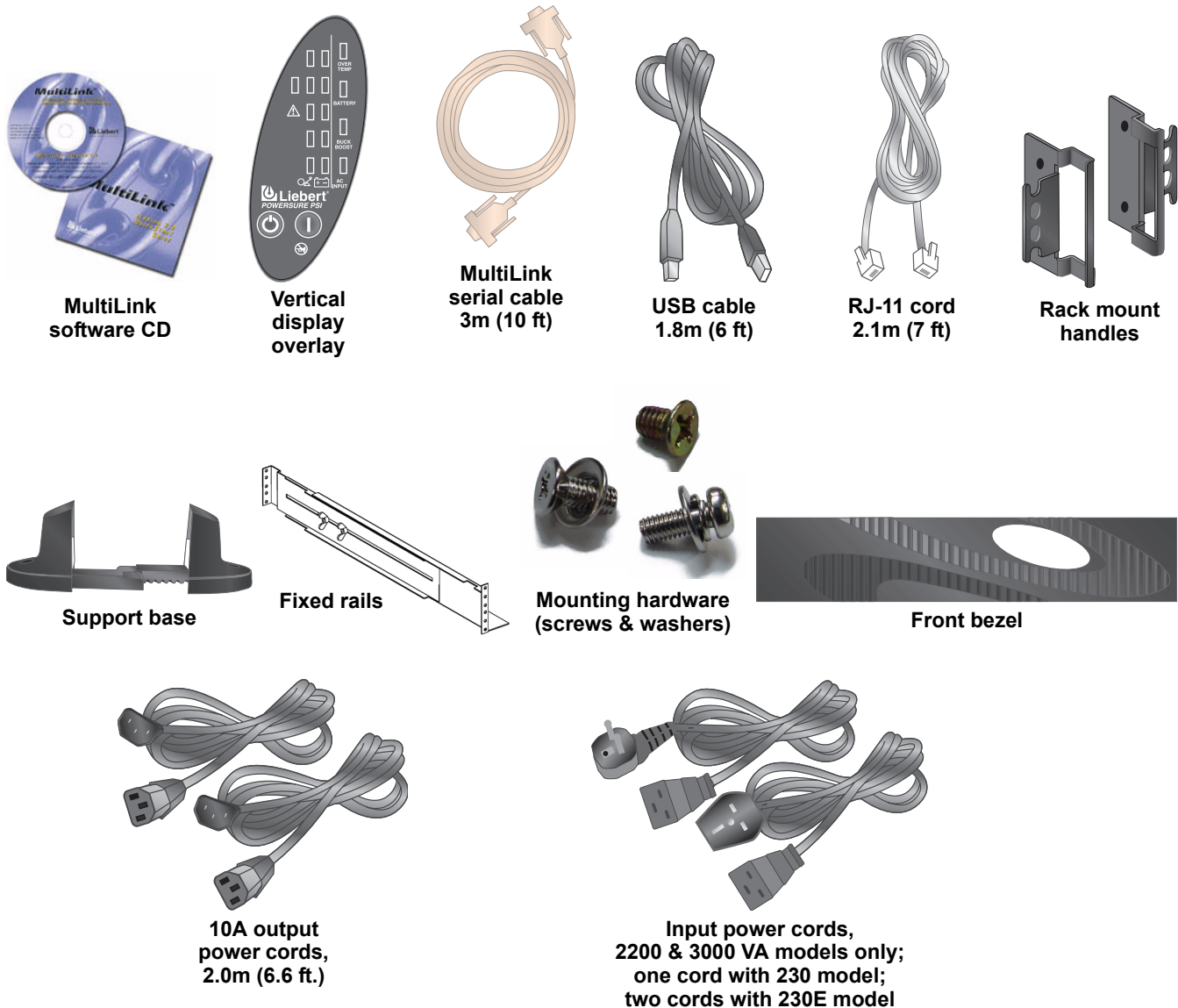

5.0 INSTALLATION

5.1 Preparation

1. Visually inspect the UPS for freight damage. Report damage to the carrier and your local dealer or Liebert representative.



CAUTION

The UPS is heavy (see **Table 4 - Battery cabinet specifications**). Take proper precautions when lifting or moving it.

2. Decide where to place the PowerSure PSI. Install the UPS indoors in a controlled environment where it cannot be accidentally turned Off. Place it in an area of unrestricted airflow around the unit, away from water, flammable liquids, gases, corrosives, and conductive contaminants. Maintain a minimum clearance of 100mm (4 inches) in the front and rear of the UPS. Maintain an ambient temperature range of 0°C to 40°C (32°F to 104°F).



NOTE

UPS operation in temperatures above 25°C (77°F) reduces battery life.

3. The PowerSure PSI may be installed in either a tower configuration or in a rack, depending on available space and use considerations. Determine the type of installation and follow the appropriate instructions in either **Tower UPS Installation** or **Rack-Mount UPS Conversion and Installation**.

5.2 Tower UPS Installation

When using the PowerSure PSI in a tower configuration, use the included support base (shown below, left) to stabilize the UPS. If two or more battery cabinets are added, the spacers—included with the battery cabinets—should be used to accommodate the additional cabinets.

Figure 6 Support base for tower configuration

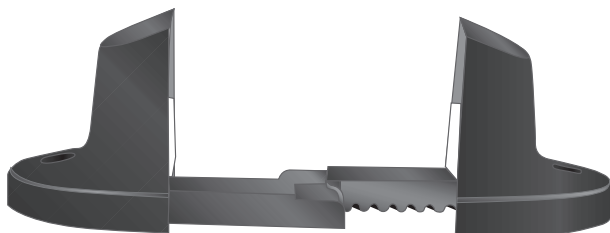

Tower Stand - Fully Extended

Spacers Can be Added to Accommodate External Battery Cabinets

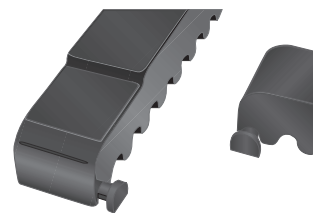

Connectors Snap into Slots on Base

1. To orient the display for vertical viewing, remove the front plastic bezel by pulling forward evenly on both sides.
2. Peel the backing from the vertical display overlay and apply to the existing display.
3. Snap the front bezel back into place.

5.3 Rack-Mount UPS Conversion and Installation



NOTE

When rack mounted, the UPS must be supported by a shelf, slide rails, brackets or fixed rails on each side. The rack mount handles **WILL NOT** support the weight of the UPS. They are used to move the UPS into and out of the rack.

1. For fixed rail installations, install the rack mount handles using four (4) M4x6 screws (see **Figure 7**).

Figure 7 Rack mount handles

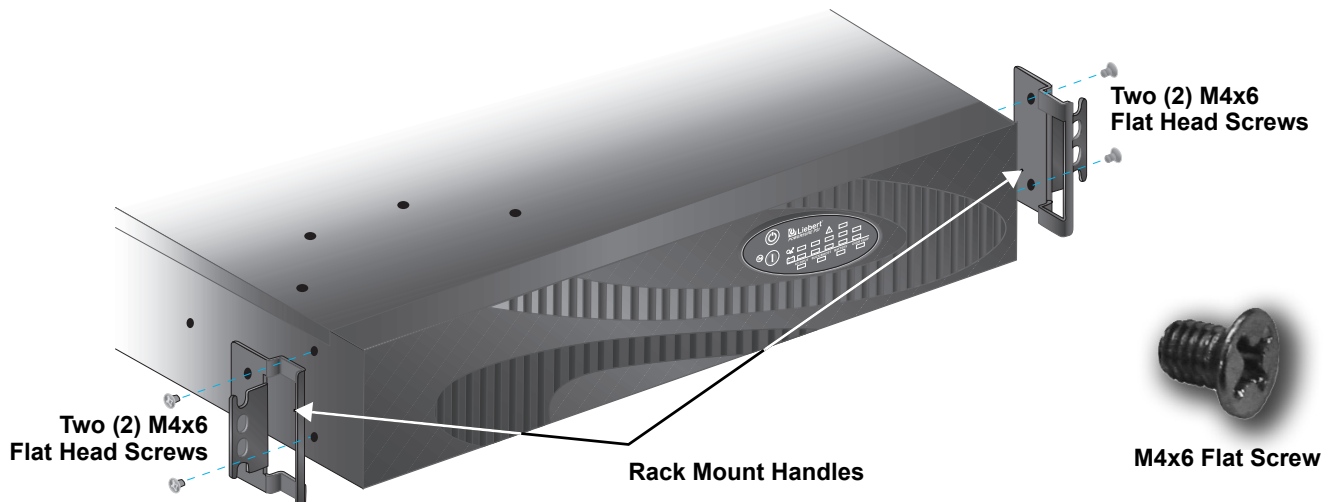

2. Unpack the two fixed rail assemblies and mounting hardware. Loosen the wing nuts and extend the inner members to their outermost position (see **Figure 8**).

Figure 8 Fixed rails with inner members extended

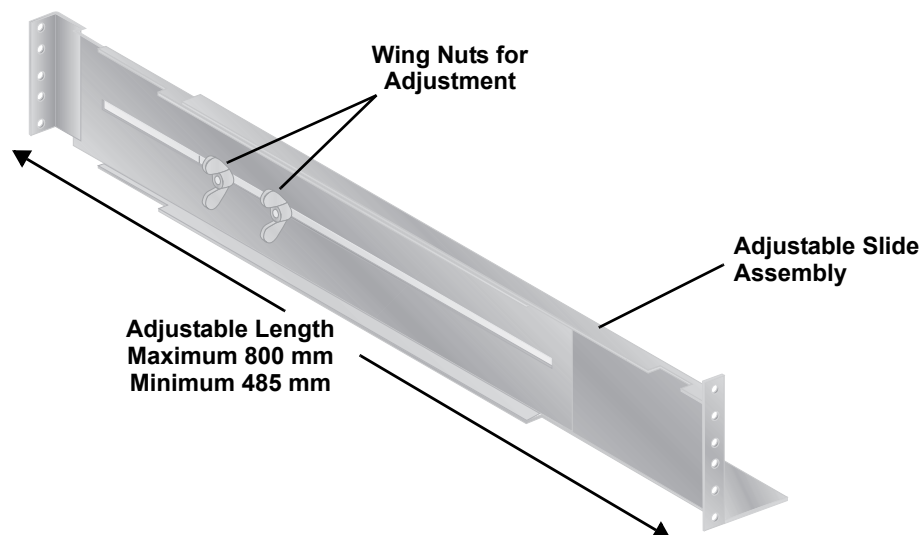

CAUTION

Reduce the risk of tipping the rack enclosure by placing the UPS or battery cabinet in the lowest possible rack position.

3. Determine the height position inside the rack enclosure where you want to mount the UPS or battery cabinet. Make sure fixed rails are at the same mounting height on each of the four (4) rack mounting rails.

4. Attach the two (2) fixed rails to the racks mounting rails. The fixed rail assemblies fit on the inside of the rack mounting rails.
5. Insert two (2) M5 flat head screws loosely (finger-tight) into the top and bottom holes on the front of the fixed rail assembly (see **Figure 9**).
6. Extend fixed rail by sliding inner member backward until it touches the rear rack mounting rail.
7. Insert two (2) M5 screws loosely (finger-tight) into top and bottom holes on the rear of the fixed rail assembly.
8. Check alignment of fixed rails and tighten all screws to ensure locking action.

Figure 9 Rack mounting rails and slide assemblies

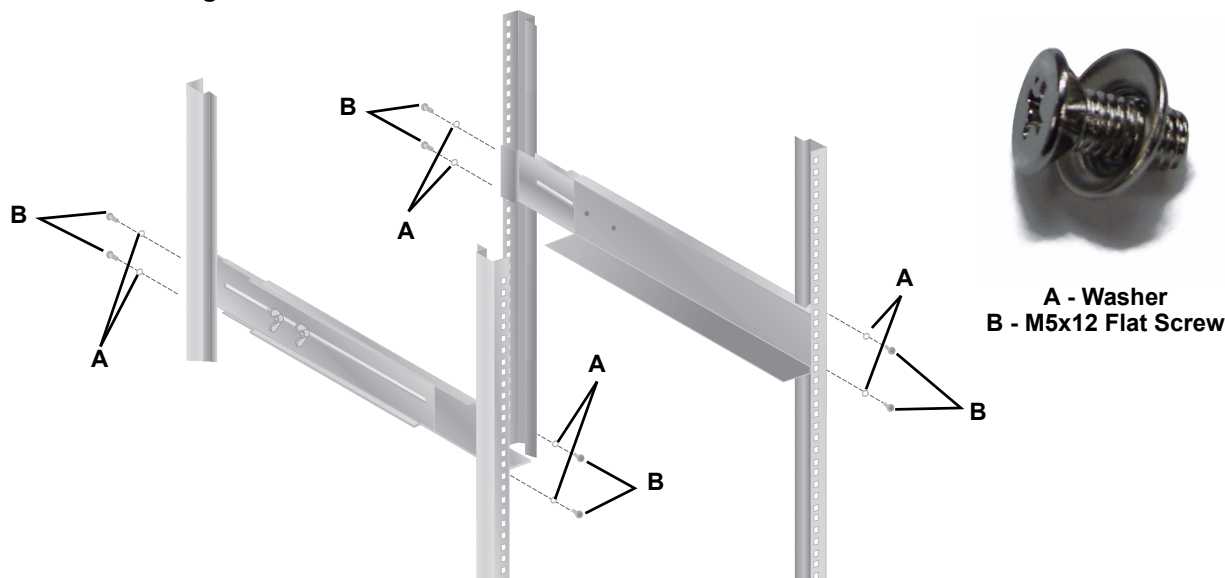

9. Lay the UPS in rack-mounting position on the fixed rails. The UPS should move smoothly forward and backward on the fixed rails. If not, recheck alignment.



CAUTION

Lifting equipment into rack may be a two-person job, depending on weight of equipment.

10. Use the extra M5 screws provided, secure front of the UPS to rack mounting rails to prevent the UPS from sliding out of position.
11. PowerSure PSI 230 VAC models are not supplied with an input power lead for connection to the mains supply. Additional input/output cords may be obtained from your dealer. The input power cord must have a minimal cross-sectional area of 1mm^2 .
12. Shut down the load equipment and turn off the mains supply. Unplug the load equipment's power input cable from the mains supply socket and plug it into the UPS input socket.
Plug the power input cable into the mains supply socket. Connect the supplied IEC-320-C14 output power cable between the load equipment input socket and one of the UPS AC output sockets.
13. Connect all load equipment to the UPS in this manner.
14. Turn On the UPS by pressing the ON button. Check that the AC Input Indicator is not flashing. If it is flashing, refer to **11.0 - Troubleshooting**. Then turn On the connected equipment. The UPS is now providing conditioned power to your equipment.

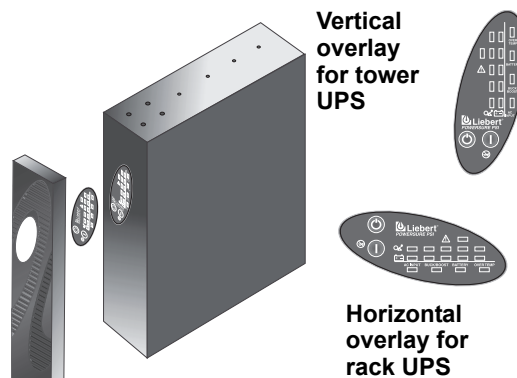

CAUTION

To maintain safety (SELV) barriers and electromagnetic compatibility, signal cables should be segregated and run separately from power cables.

15. Connect Phone/Fax/DSL/Network/Modem devices to data line connectors.

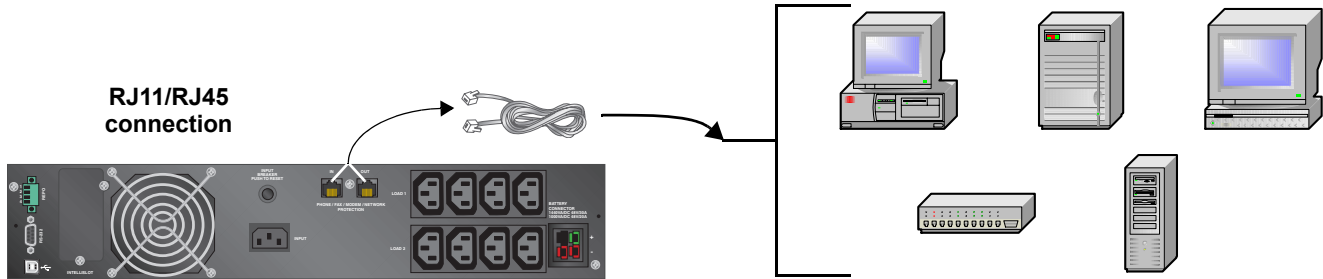

16. Communication options (see **8.0 - Communications** for details):

Option 1 - Serial Communications

Serial communications provides parametric data, for example, input voltage and battery voltage.

- Connect MultiLink serial cable included with the UPS to communications port.
- Install the MultiLink software. The software and installation instructions, as well as the user manual, are on the CD included in the PowerSure PSI package.

Option 2 - Contact Closure Communications

Contact Closure communications provides on-battery and low-battery signals for orderly shut-down.

- Refer to the MultiLink user manual for instructions on making your own contact closure cable.
- Install the MultiLink software. The software and installation instructions, as well as the user manual, are on the CD included in the PowerSure PSI package.

Option 3 - USB Communications

- Connect USB cable provided with the UPS to the PSI's USB port and the USB port on your computer. The PSI will work automatically with your built-in power management software on Windows XP and 2000 and Mac OS 10.2 or later (see **8.3 - USB Interface Port** for details).

Option 4 - Intellislot

The UPS contains one communication slot, called "Intellislot™," to allow the operator to field install optional communication cards. These optional cards allow the UPS to communicate via either OpenComms Web Card (OCWEBCARD), connected directly to the LAN; or Intellislot Relay Interface card (RELAYCARD-INT) communication card. Once the OCWEBCARD is installed, the Serial communication via the RS232 is disabled. The USB, Intellislot, and Contact Closure communications operate in parallel.

17. REPO Switch—The PowerSure PSI is equipped with a Remote Emergency Power Off (REPO) switch.

The user must supply a means of interfacing with the REPO circuit to allow disconnecting the UPS input feeder breaker to remove all sources of power to the UPS and connected equipment to comply with national and local wiring codes and regulations.

Figure 10 REPO switch connections

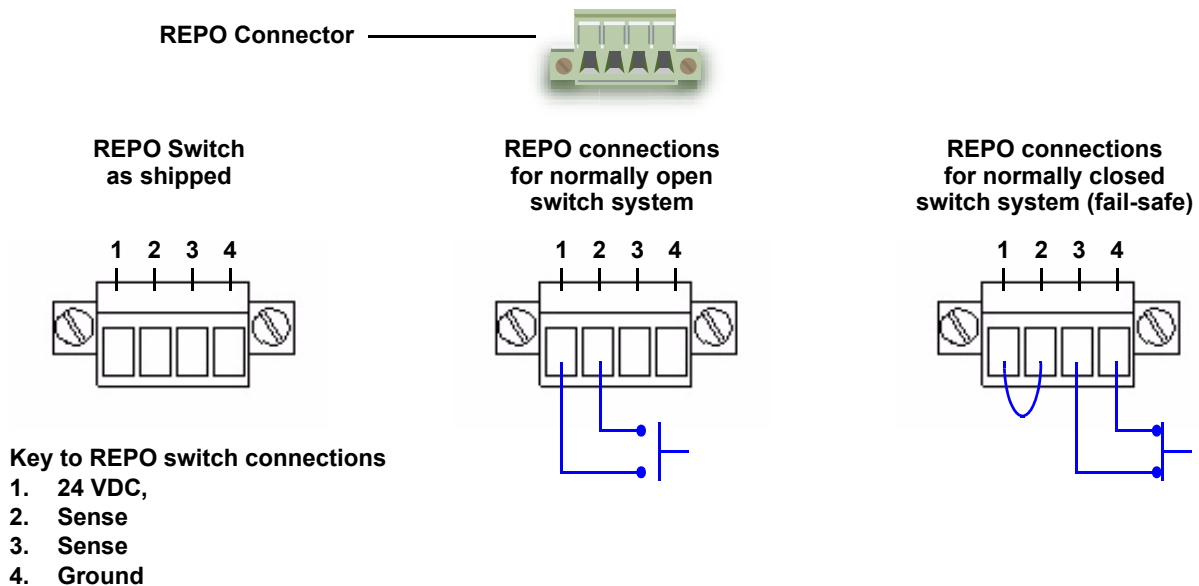

5.4 External Battery Cabinet Installation

Optional Liebert external battery cabinets may be connected to the UPS to provide additional battery run time. External battery cabinets are designed to be placed all on one side of the UPS or stacked beneath the UPS. The run time is limited to a maximum of four (4) hours.



CAUTION

The external battery cabinet(s) are heavy (see **12.0 - Specifications**). External battery cabinets can be used in rack-mount or tower configuration. Take proper precautions when lifting them.

1. Visually inspect the external battery cabinet for freight damage. Report damage to the carrier and your local dealer or Liebert representative.
2. The rack-mount handles are shipped with the external battery cabinet and may be installed at this time (see **5.3 - Rack-Mount UPS Conversion and Installation**).
3. Fixed rails and securing hardware ship with the external battery cabinet. Fasten the fixed rails into position with the screws per the instructions included with the UPS. Repeat **Steps 1 through 10** from **5.3 - Rack-Mount UPS Conversion and Installation**.
4. Use the support bases included with the UPS for the tower option to prevent tip-over. One additional set of support base spacers ships with each external battery cabinet.
5. Connect the supplied external battery cabinet cable to the rear of the external battery cabinet, then to the rear of the UPS, as shown at right.
6. The UPS is now equipped with additional backup battery run time. For approximate battery run times, refer to **Table 5 - Battery run times**.

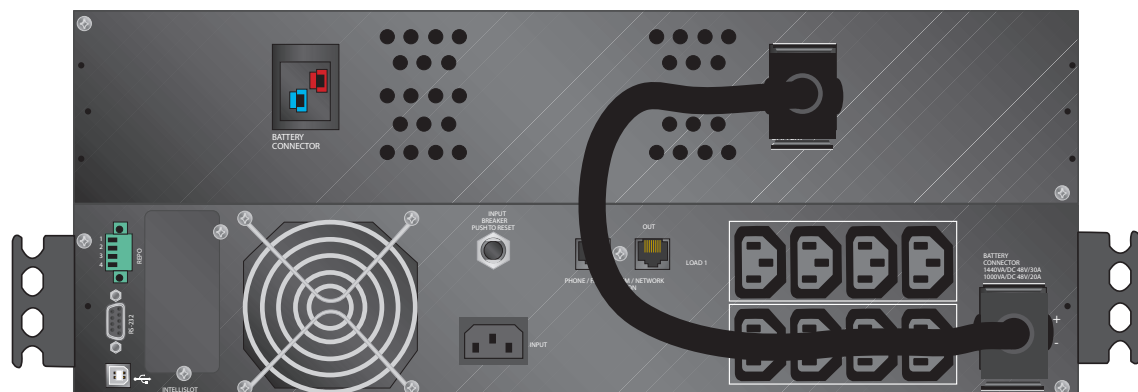

6.0 CONTROLS AND INDICATORS



6.1 ON/Alarm Silence/Battery Test Button

This button controls output power to connected load(s) and has three functions:

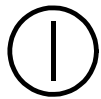

- On
- Alarm Silence
- Battery Test

ON—When the UPS is Off, pressing the ON/Alarm Silence/Battery Test button **for more than one (1) second** will start the UPS, and an audible alarm sounds briefly. The UPS is capable of starting on battery (battery start).

Alarm Silence—When a UPS audible alarm is active, pressing and releasing the ON/Alarm Silence/Battery Test button will silence the active audible alarm, whether mains power is present or not. Once the alarm silence function has been activated, all active audible alarms will remain silenced until a new alarm condition is detected.



NOTE

The LOW BATTERY, OVER TEMP and OVERLOAD warning audible alarms CANNOT be silenced.

Battery Test—To initiate a manual battery test, press the ON/Alarm Silence/Battery Test button for at least one second while operating from mains power with no alarm conditions present.

- If all five (5) Battery indicators are not illuminated, allow the UPS to recharge the batteries for 24 hours.
- After 24 hours, retest the batteries.
- After the batteries have been retested, if all five (5) Battery indicators are not illuminated, contact your local dealer, Liebert representative or Liebert Worldwide Support Group.

6.2 OFF Button



When the UPS is on (in either Normal or Battery mode), pressing the OFF button **for more than one (1) second** will shut down the UPS. An audible alarm sounds briefly.

6.3 Voltage Programming Button

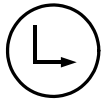

The PowerSure PSI contains a Voltage Programming button that allows the operator to select the nominal mains voltage. This setting changes the mains transfer points (low and high) of the UPS and the nominal output voltage when operating in Battery mode. The operator can select between 220, 230 and 240VAC output. The factory-default setting is 230VAC.

The Voltage Programming button is a push button type and is behind the plastic bezel on the front panel of the UPS. To access the button, the front bezel must be removed.

6.4 Load Level Indicators—4 green, 1 amber

The Load Level Indicators display the approximate electrical load placed upon the UPS.

The UPS Load Level Indicators are displayed in 25% increments as shown in **Figure 11**.

Figure 11 Load level indicators—4 green, 1 amber



Upon detection of an output overload condition, the amber overload (>100%) indicator flashes and an audible alarm activates. If the UPS shuts down due to an overload condition, the amber overload (>100%) indicator illuminates (see **11.0 - Troubleshooting** for details).

6.5 Battery Level Indicators—5 green

The Battery Level Indicators display the approximate battery capacity.

The approximate battery capacity is displayed when the UPS is operating in Normal, Buck/Boost, or Battery mode.

The Battery Level Indicators are displayed in 20% increments as shown in **Figure 12**:

Figure 12 Battery level indicators—5 green



The PowerSure PSI is equipped with automatic and remote battery test features. The automatic test occurs every 14 days if mains has not been interrupted; this option may be configured by the user. Should the battery fail this test, the amber Battery Indicator will be illuminated and an alarm will sound (see **11.0 - Troubleshooting** for details).

The remote test feature functions with MultiLink 3.x software and can remotely initiate the battery test.

6.6 AC Input Indicator—Green

The AC Input Indicator illuminates when mains power is available and within the input specifications.

6.7 Buck/Boost Indicator—Green

The Buck/Boost Indicator illuminates when the UPS is operating in Boost mode to compensate for a low mains voltage condition. This indicator flashes when the UPS is operating in Buck mode to compensate for a high mains voltage condition (see **11.0 - Troubleshooting** for details).

6.8 Battery Indicator—Green/Amber

The Battery Indicator illuminates green when the UPS is operating on battery and flashes green when a low battery condition occurs. The Battery Indicator illuminates amber when a bad battery is detected, indicating that the batteries need to be replaced (see **11.0 - Troubleshooting** for details).

6.9 Over Temp Indicator—Amber

The Over Temp Indicator flashes when the UPS detects an over temperature condition. This indicator illuminates when the UPS shuts down due to an over temperature condition (see **11.0 - Troubleshooting** for details).

6.10 Fault Indicator—Red



The Fault Indicator illuminates when the UPS detects an internal problem (see **11.0 - Troubleshooting** for details).

7.0 MODES OF OPERATION

7.1 Normal Mode

During Normal mode operation, the PowerSure PSI supplies conditioned, computer-grade power to the connected equipment: mains power passes through the TVSS circuitry and the EMI/RFI filters and then through the Inverter (1000VA & 1440VA) / Bi-Directional Converter (2200VA & 3000VA) to connected equipment.

When the UPS is in Normal mode, the AC Input Indicator illuminates green. The UPS display in **Figure 13** shows the UPS operating in Normal mode with 26% - 50% load connected to the output.

Figure 13 Normal mode operation with 26-50% load

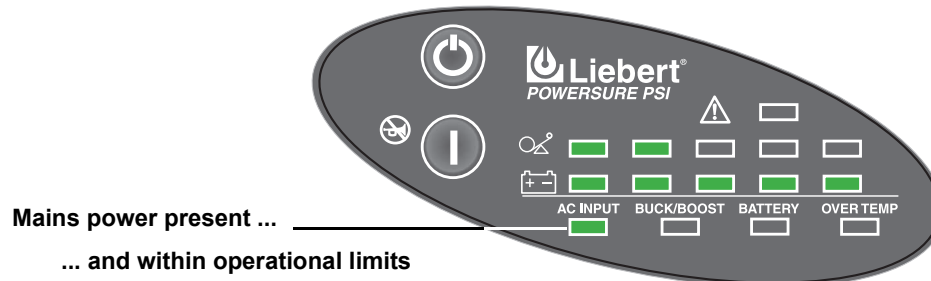

The PowerSure PSI continuously monitors the batteries to maintain them in a fully charged state. The battery charger operates whenever AC power is present, even if the UPS is switched Off. By default, the UPS is set to perform an automatic battery test after it has been operating continuously for two (2) weeks. The automatic battery test can be disabled via MultiLink.

7.2 Buck/Boost Mode

The Automatic Voltage Regulator (AVR) circuitry compensates for fluctuations in mains power, such as voltage surges and sags. When the PowerSure PSI detects an abnormality, it raises the undervoltage (boost) or lowers the overvoltage (buck) as needed. The AVR operates automatically and maintains the output voltage to the connected critical equipment, without utilizing the batteries.

The Buck/Boost Indicator flashes green when the UPS is operating in Buck mode and illuminates green when the UPS is operating in Boost mode (see **11.0 - Troubleshooting** for details).

Figure 14 Buck/Boost mode operation with 51-75% load and 21-40% battery capacity

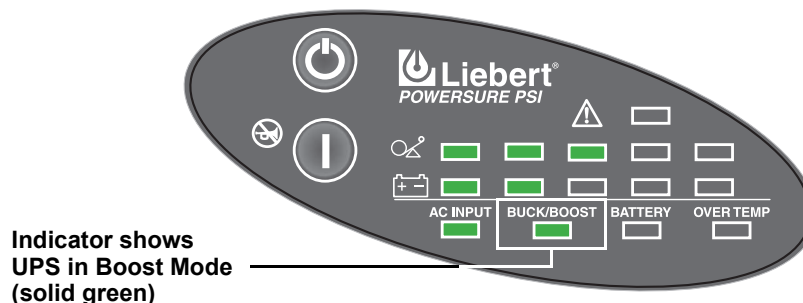

7.3 Battery Mode

The UPS switches to Battery mode in the event of an extreme input voltage/frequency condition or complete mains failure. The battery system supplies power through the Inverter (1000VA & 1440VA) or through the DC-to-DC converter to the Bi-Directional Converter (2200VA & 3000VA) to generate power for the connected equipment.

When the UPS is in Battery mode, the Battery Indicator illuminates green and an alarm sounds every 10 seconds. As capacity decreases, fewer indicators remain illuminated. **Figure 15** shows the UPS in Battery mode with 61% - 80% battery capacity remaining.

Figure 15 Battery mode at 61 – 80% battery capacity

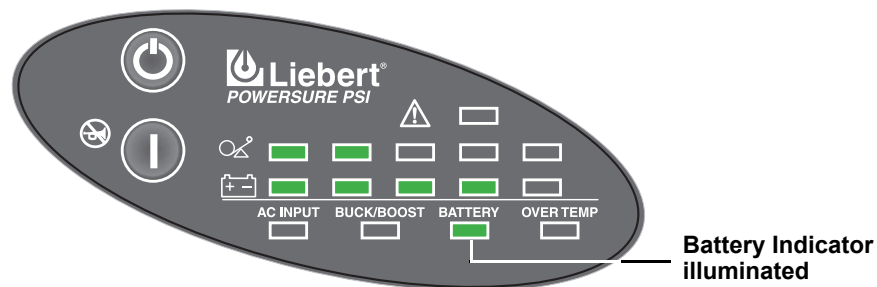

When a low battery condition occurs, the Battery Indicator flashes green and the alarm sounds every half-second. The default low battery warning is two (2) minutes but can be configured via MultiLink. For more information, refer to **11.0 - Troubleshooting**.

Figure 16 Low Battery mode

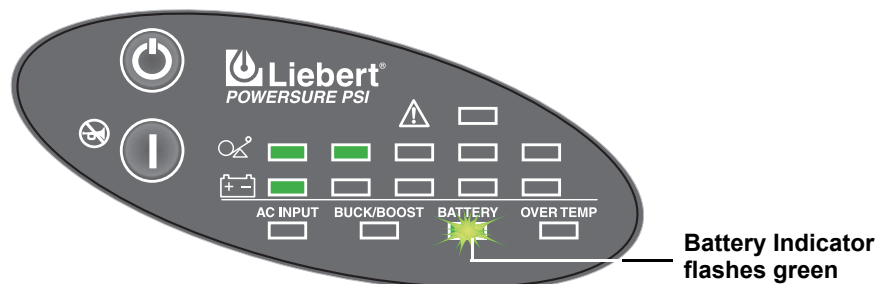

For approximate battery run times, refer to **Table 5 - Battery run times**. These run times are approximate based on resistive load and an ambient temperature of 25°C (77°F). To increase this time, turn Off non-essential pieces of equipment, such as idle computers and monitors, or add external battery cabinets.



CAUTION

Turning Off the UPS while it is in battery mode will result in loss of output power.

7.4 Battery Recharge Operation

Once mains power is restored, the UPS resumes normal operation. At this time, the Battery Charger begins recharging.

8.0 COMMUNICATIONS

8.1 DB-9 Connector

The UPS has a DB-9 (9 pin female) connector on the rear to allow UPS status communications with a computer system running MultiLink software. The DB-9 is capable of supplying serial communication, on battery and low battery signals. MultiLink, Liebert's UPS monitoring and shutdown software, is shipped with the UPS, along with a 3m (10 ft) DB-9 cable required for running MultiLink.

When MultiLink is installed on the host computer, the UPS can signal "on battery" and "low battery" using opto-couplers. When the UPS is operating in Battery mode, it can receive a signal from the host computer system that will shut down the UPS (after gracefully shutting down the operating system on the host computer system) when the remaining battery run time is low. The timing of the signal depends on MultiLink's configuration settings. This shutdown signal (5-12VDC) must have a duration of at least 2 seconds for the UPS to be shut down. The UPS communicates via serial communications using Liebert ESP II protocol.

Table 1 DB-9 pin assignment

DB-9 Pin	Assignment Description
1	Low Battery (open collector)
2	UPS TxD
3	UPS RxD
4	Battery Mode Shutdown (5-12V)
5	Common
6	Any Mode Shutdown (short to pin 5)
7	Low Battery (open emitter)
8	Mains Fail (open emitter)
9	Mains Fail (open collector)

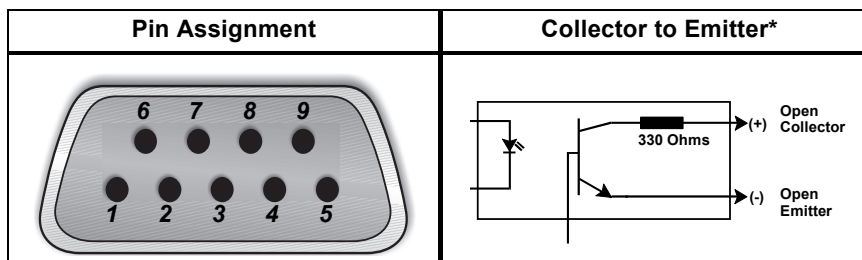

8.2 Remote Shutdown Via the DB-9 Connector

The PowerSure PSI can be shut down remotely by shorting Pins 5 and 6 or via Pins 4 and 5 of the DB-9 connector.

8.2.1 Any Mode Shutdown—Via Pins 5 & 6

When Pin 6 is shorted to Pin 5, the UPS output is shut Off regardless of what mode the UPS is operating in. The UPS cannot be started as long as the pins are shorted. When the short is removed, the UPS output can be enabled by pressing the ON/Alarm Silence/Battery Test button.

8.2.2 Battery Mode Shutdown—Via Pins 4 & 5

While the UPS is operating on battery (with no battery test in progress), a 5-12VDC signal for 2 seconds or longer is required to signal a shutdown. Signals for less than 2 seconds are ignored.

After Pin 4 receives the shutdown signal, a 2-minute shutdown timer inside the UPS begins a countdown. The timer cannot be stopped. If mains power returns during the 2-minute timer countdown, the shutdown timer continues until the end of 2 minutes and then the UPS turns Off. By default, autorestart is enabled so the UPS will restart after 10 seconds. If autorestart is disabled via MultiLink software, the UPS remains Off until a manual restart.

8.3 USB Interface Port

The PowerSure PSI has a USB interface port for communication that will work with the built-in Microsoft Power Manger software on the user's PC, if so equipped. It will provide UPS status and manages the automatic orderly shutdown of the computer. The UPS's USB communications meet HID standard, version 1.11. All USB models are compatible with Microsoft Windows 2000, Windows XP and Mac OS 10.2 or later. All USB models ship with a 1.8m (6 ft) USB cable.

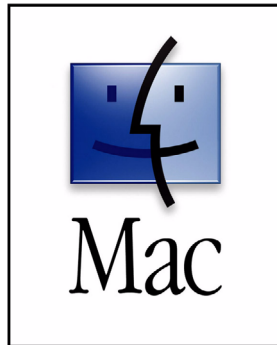

Microsoft, Windows, and the Windows logo are trademarks, or registered trademarks of Microsoft Corporation in the United States and/or other countries.

8.4 Data Line Protection Connectors

Data line (in and out) connectors are on the rear of the UPS and provide transient voltage surge suppression (TVSS) for Phone/Fax/DSL/Internet/Modem devices.

8.5 UPS Intelligent Communications

The PowerSure PSI is equipped with an Intellislot[®] port to provide advanced communication and monitoring options.

Liebert's MultiLink software continually monitors the UPS and can shut down your computer or server in the event of an extended power failure.

MultiLink can also be configured for use without the serial cable when the Intellislot OCWEBCARD is installed in the UPS. Additionally, MultiLink can be configured to coordinate shutdown across the network with other computers running MultiLink when you purchase a MultiLink License Kit. For more information about the Intellislot OCWEBCARD and MultiLink License Kits, visit our Web site (www.liebert.com) or contact your local dealer or Liebert representative.

Several option cards are available for use in the Intellislot port of the PowerSure PSI. The Intellislot OCWEBCARD provides SNMP and Web-based monitoring and control of the UPS across the network. The Intellislot MultiPort 4 Card allows you to install MultiLink software on four computers and coordinate shutdown in the event of a power failure.

The RELAYCARD-INT provides dry contact relay outputs for custom-wired applications and delivers support for built-in shutdown for AS/400 systems.



NOTE

The USB, Intellislot and Contact Closure communications operate in parallel. Using the OCWEBCARD disables the Serial Communications of the DB-9.



CAUTION

To maintain safety (SELV) barriers and for electromagnetic compatibility, signal cables should be segregated and run separate from all other power cables, where applicable.

9.0 VOLTAGE PROGRAMMING PROCEDURE

Figure 17 Load Level Indicators

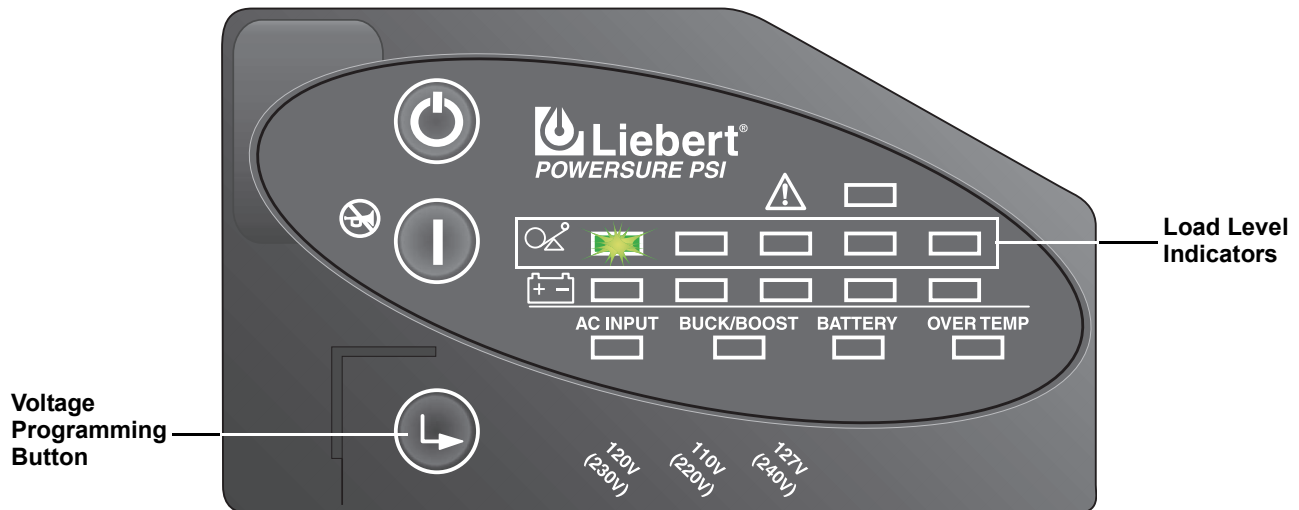

1. Remove the front bezel from the UPS.
2. UPS must be operating in Normal (AC) mode.



NOTE

Mains power will be applied to the connected load.

3. The AC Input, Load, and Battery Level Indicators should be lit.
4. Press the Voltage Programming button for at least 5 seconds to enter the Configuration mode. The UPS will beep and all of the indicators on the front panel display will flash on and off for approximately 5 seconds. The next cycle will display the current configuration, either 220, 230 or 240 VAC. One of the Load Level Indicators will be flashing. Initially, the 0%-25% Load Level Indicator will be flashing, indicating the default setting of 230V as shown in **Figure 17**.
5. Press the ON button to step through the voltage settings until the appropriate Load Level Indicator is flashing.
6. Press the Voltage Programming button. The UPS will return to Normal mode operation.

The Voltage Programming button allows the operator to select the mains transfer voltage at which the UPS will switch to battery power. This also changes the inverter voltages. The voltage settings are as follows:

Setting	Input Voltage Range	Output Voltage (Battery Mode)
120V (230V)	166 - 272VAC (default)	230VAC
110V (220V)	158 - 260VAC	220VAC
127V (240V)	172 - 283VAC	240VAC

10.0 MAINTENANCE

The PowerSure PSI UPS requires very little maintenance. Follow these practices to prevent problems.

10.1 Cleaning the UPS

The following will help ensure trouble-free operation for years:

- Vacuum dust from the ventilation intake occasionally.
- Wipe the cover periodically with a dry cloth.

10.2 Maintaining Batteries

The batteries are valve-regulated, nonspillable, lead acid and must be kept charged to retain their design life. The UPS continuously charges the batteries when connected to the mains supply, even while the UPS is switched Off.

When storing the UPS, it is recommended to plug in the UPS for at least 24 hours every four to six months to ensure full recharge of the batteries.

The PowerSure PSI is designed to allow the user to replace the internal batteries safely. Read the safety cautions before proceeding. Contact your local dealer or Liebert representative to obtain the appropriate replacement battery kit part number and pricing.

10.3 Battery Replacement



CAUTION

A battery can present a risk of electrical shock and high short circuit current. The following precautions should be observed before replacing the batteries:

- Remove rings, watches, and other metal objects.
- Use a Phillips (crosshead) screwdriver with insulated grips.
- Do not lay tools or other metal objects on top of the batteries.
- If the battery replacement kit is damaged in any way or shows signs of leakage, contact your local dealer or Liebert representative immediately.
- Do not dispose of batteries in a fire. The batteries may explode.
- Dispose of old batteries according to local codes.
- Risk of explosion if battery is replaced by an incorrect type. Refer to **12.0 - Specifications** for battery information.
- Do not open or mutilate the batteries. Released electrolyte is harmful to skin and eyes. It is toxic.



NOTE

This UPS is equipped with internal "hot swappable" batteries that the user can replace without shutting down the UPS or connected loads. Caution should be exercised when replacing the batteries because the load is unprotected from disturbances and power outages during this procedure.

10.3.1 Internal Battery Replacement Procedure

1. Gently remove the front plastic bezel cover from the UPS.
2. Loosen and remove the five (5) screws on the front cover plate. Lay the cover plate aside for reassembly.
3. Loosen and remove four (4) screws on battery bracket.
4. Disconnect the two (2) slotted, red and black battery connectors.
5. Grasp the battery pack assembly by the pull tab and pull it out of the front of the UPS.
6. Unpack the new battery assembly, taking care not to destroy the packing. Compare new and old battery assemblies to make sure they are the same. If so, proceed with **Step 7**; otherwise STOP and contact your local dealer, Liebert representative, or the Liebert Worldwide Support Group.
7. Slide in the new replacement battery pack.
8. Reattach the battery bracket with the four (4) screws.
9. Reconnect the two (2) slotted red and black battery connectors.
10. Reattach the front battery door with the five (5) screws.
11. Reattach the front plastic bezel cover to the UPS.

Figure 18 Battery replacement procedure

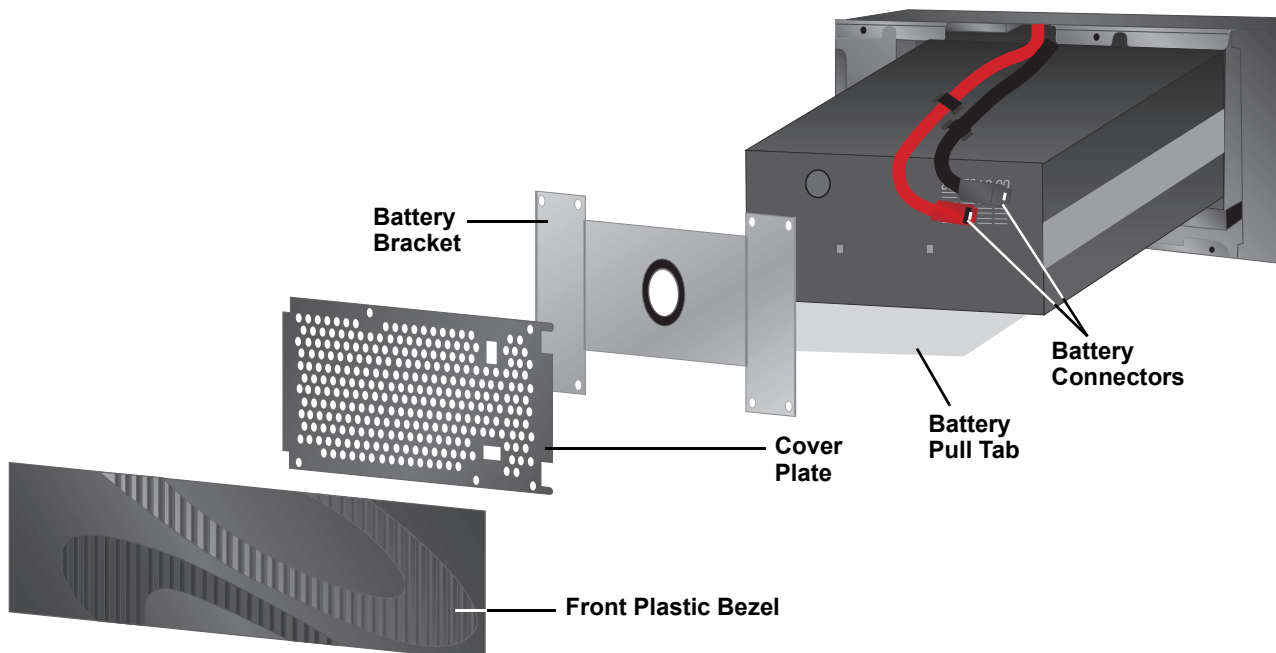

11.0 TROUBLESHOOTING

The information below indicates various symptoms a user may encounter in the event the PowerSure PSI experiences a problem. Use this information to determine whether external factors caused the problem. See **Table 2 - Troubleshooting chart** for suggested remedy.

1. An alarm sounds, alerting that the UPS requires attention. The alarm can be silenced except for low battery, overload warning and over-temperature warning conditions.
2. One or more additional indicators will be illuminated to provide a diagnostic aid to the operator, as described below:

Figure 19 Status indicators

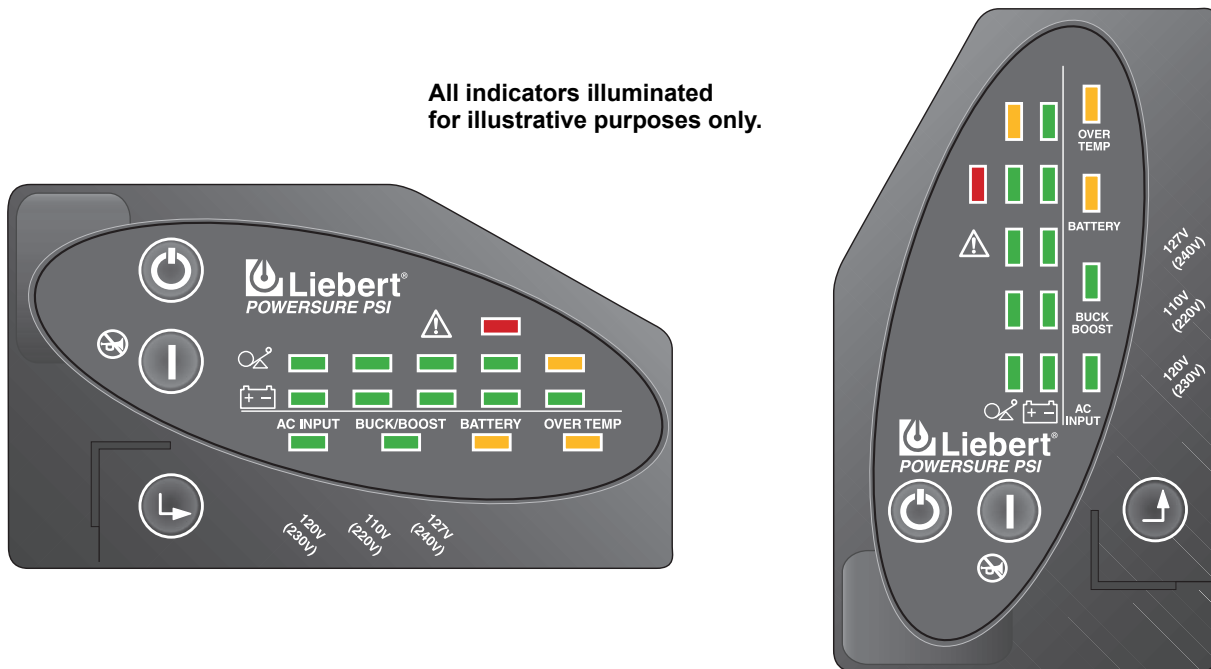

If the UPS fails to operate properly, turn Off the unit and repeat the steps in **5.0 - Installation**. If the problem persists, refer to **Table 2**:

Table 2 Troubleshooting chart

Problem	Cause	Solution
UPS will not start	Short circuit	Check the circuit protector on the rear of the UPS. If it is tripped, reset it and restart the UPS. For further help, contact your local dealer, Liebert representative or the Liebert Worldwide Support Group.
	Battery disconnected or is completely discharged	Check for proper connection of battery or batteries.
UPS starts on battery, but will not switch to AC	UPS not plugged in	Plug in the power cord securely.
	Circuit protector tripped	Reset the circuit protector and restart the UPS.
	Input voltage below threshold	Wait until the voltage rises to an appropriate level or have the mains power checked by a qualified electrician.
	AC overvoltage	Wait until voltage lowers to an appropriate level or have the mains power checked by a qualified electrician.
UPS shuts down	Load exceeded UPS capacity (110%), All Load Level Indicators are illuminated; continuous beep	Check load level display and remove non-essential loads. Recalculate the load and reduce number of loads connected to UPS - the total wattage of your equipment must not exceed the capacity of the UPS.
	Over temperature shutdown, Over Temp Indicator lit; continuous beep	Make sure that the UPS is operating in 0°C to 40°C (32°F to 104°F) and that it has adequate ventilation.
	MultiLink shutdown	Consult the MultiLink user manual or contact your LAN administrator.
	Internal UPS fault, Fault Indicator Lit; continuous beep	Contact your local dealer, Liebert representative or the Liebert Worldwide Support Group.
	UPS shutdown due to a command from the communications port(s), Load Level 0-25% Indicator illuminated	Your UPS has received a signal or command from the attached computer. If this was inadvertent, ensure the communication cable used is correct for your system. For assistance, contact your local dealer, Liebert representative or the Liebert Worldwide Support Group.
All Battery Level Indicators flashing	UPS is unable to perform manual or remote battery test; beep every half second for five seconds	Check battery connections, completely power down and restart UPS. NOTE: If the battery circuit opens while the UPS is running, it will be detected when the next battery test is performed.
Battery Indicator illuminated amber; long beep every minute	UPS failed battery test	Initiate battery test again.
	Batteries weak	Recharge batteries.
	Batteries need to be replaced	Replace batteries.
Over Temp Indicator flashing	Over temperature warning; beep every half second	Make sure that the UPS is operating in 0°C to 40°C (32°F to 104°F) and that it has adequate ventilation.
Fault Indicator lit but UPS is On	Fault warning; beep every half second	Reset UPS.

12.0 SPECIFICATIONS

Table 3 UPS specifications

Model Number	PS1000RT2-230	PS1440RT2-230	PS2200RT2-230 PS2200RT2-230E	PS3000RT2-230 PS3000RT2-230E
Power Rating, VA/W	1000VA/750W	1440VA/1080W	2200VA/1650W	3000VA/2250W
Dimensions, W x D x H, mm (in)				
Unit	87 x 557 x 430 (3.43 x 22 x 17)	87 x 557 x 430 (3.43 x 22 x 17)	87 x 612 x 430 (3.43 x 24.1 x 17)	87 x 612 x 430 (3.43 x 24.1 x 17)
Shipping	300 x 706 x 598 (11.8 x 27.8 x 23.5)	300 x 706 x 598 (11.8 x 27.8 x 23.5)	333 x 864 x 598 (13.1 x 34 x 23.5)	333 x 864 x 598 (13.1 x 34 x 23.5)
Weight, kg (lbs)				
Unit	28 (61.7)	31.0 (68.2)	35.0 (77.0)	37.0 (81.6)
Shipping	36.6 (80.7)	39.0 (85.8)	43.6 (95.9)	45.6 (100.5)
Input AC Parameters				
Rated Input Voltage	220/230/240VAC			
Surge Protection	660J			
Voltage Range Without Battery Operation	158VAC - 283VAC, configurable			
Frequency Range	45 - 65 Hz (± 0.1 Hz)			
Input AC Inlet	IEC-320-C14	IEC-320-C14	IEC-320-C20	IEC-320-C20
Output AC Parameters				
Output Receptacles	(8) IEC-320-C13	(8) IEC-320-C13	(8) IEC-320-C13 (1) IEC-320-C19	(8) IEC-320-C13 (1) IEC-320-C19
Voltage (Normal mode)	220/230/240VAC (configurable) $\pm 10\%$			
Voltage (Battery Mode)	220/230/240VAC (configurable); $\pm 5\%$ before low battery warning; $\pm 8\%$ after low battery warning			
Transfer Time	4-6 ms typical			
Waveform	Sinewave			
Frequency (Normal Mode)	45 - 65 Hz (± 0.1 Hz)			
Frequency (Battery Mode)	50 or 60 Hz (± 0.5 Hz); auto sensing			
Overload Warning	$> 100 - 110\%$			
Overload Shutdown	$> 200\%$ - short circuit; after 15 cycles (normal mode)			
Battery Parameters				
Type	Valve-regulated, nonspillable, lead acid			
Quantity x Voltage x Rating	4 x 12V x 7Ah	4 x 12V x 7Ah	6 x 12V x 7Ah	6 x 12V x 9Ah
Battery Manufacturers	CSB, B&B Battery, and EnerSys			
Backup Time	See Table 5 - Battery run times			
Full Load	11	5	5	6
Half Load	26	16	16	16
Recharge Time	4 hours to 90% of rated capacity, after full discharge into resistive load			
Environmental				
Operating Temperature	0°C to + 40°C (+32°F to + 104°F)			
Storage Temperature	-15°C to + 40°C (+5°F to + 104°F)			
Relative Humidity	0% to 95%, non-condensing			
Operating Altitude	Up to 2,000m (6,500 ft) at 35°C (95°F) without derating		Up to 3,000m (10,000 ft) at 35°C (95°F) without derating	
Audible Noise	<40 dBA, internal fan(s) Off <50 dBA, internal fan(s) On		<40 dBA, internal fan(s) Off <60 dBA, internal fan(s) On	

Table 3 UPS specifications (continued)

Model Number	PS1000RT2-230	PS1440RT2-230	PS2200RT2-230 PS2200RT2-230E	PS3000RT2-230 PS3000RT2-230E
Agency				
Safety	EN 62040-1-1; TUV/GS listed; CE compliance mark			
Surge	EN61000-4-5, Level 3, Criteria B			
ESD	EN61000-4-2, Level 3, Criteria B			
Susceptibility	EN61000-4-3, Level 3, Criteria A			
Electrical Fast Transient	EN61000-4-4, Level 4, Criteria A			
Emissions	EN 50091-2, Class B			
Conducted Immunity	EN61000-4-6			
Harmonics	EN61000-3-2			
Flicker	EN61000-3-3			
Transportation	ISTA Procedure 1A Certification			

Table 4 Battery cabinet specifications

Model Number	PS2-48VBATT	PS2-72VBATT
Used w/UPS Model	PS1000RT2-230 PS1440RT2-230	PS2200RT2-230 PS3000RT2-230
Dimensions, W x D x H, mm (in)		
Unit	87 x 557 x 430 (3.43 x 22 x 17)	87 x 612 x 430 (3.43 x 24.1 x 17)
Shipping	300 x 706 x 598 (11.8 x 27.8 x 23.5)	333 x 864 x 598 (13.1 x 34 x 23.5)
Weight, kg (lbs)		
Unit	30 (66.1)	46 (101.4)
Shipping	38.6 (85.1)	53.6 (118.1)
Battery Parameter		
Type	Valve-regulated, nonspillable, lead acid	
Quantity x Voltage x Rating	2 strings of 4 x 12V x 7Ah	2 strings of 6 x 12V x 9Ah
Battery Manufacturers	CSB, B&B Battery and EnerSys	
Backup Time	See Table 5 - Battery run times	
Environmental		
Operating Temperature	0°C to + 40°C (+32°F to + 104°F)	
Storage Temperature	-15°C to + 40°C (+5°F to + 104°F)	
Relative Humidity	0% to 95%, non-condensing	
Operating Altitude	Up to 3,000m (10,000 ft) at 35°C (95°F) without derating	
Agency		
Safety	EN 62040-1-1; TUV/GS listed; CE compliance mark	
Emissions	EN 50091-2, Class B	
Transportation	ISTA Procedure 1A Certification	

Table 5 Battery run times

	Load%	1000VA	1440VA	2200VA	3000VA
Internal Battery (minutes)	5%	174	138	171	177
	10%	118	79	73	91
	20%	65	45	47	47
	30%	41	28	26	28
	40%	37	24	23	22
	50%	26	16	16	16
	60%	24	14	13	14
	70%	18	10	10	10
	80%	16	9	8	9
	90%	12	6	6	7
	100%	11	5	5	6
Internal Battery + 1 External Battery Cabinet (minutes)	5%	513	409	542	542
	10%	305	265	266	257
	20%	248	188	185	148
	30%	177	125	135	141
	40%	139	104	122	99
	50%	119	72	99	67
	60%	98	59	75	53
	70%	75	45	55	45
	80%	63	40	49	39
	90%	53	35	44	34
	100%	46	30	40	29
Internal Battery + 2 External Battery Cabinet (minutes)	5%	1001	828	—	—
	10%	565	461	493	444
	20%	409	283	291	249
	30%	283	219	222	168
	40%	248	177	194	148
	50%	209	133	150	129
	60%	166	122	137	114
	70%	136	98	122	92
	80%	127	84	107	71
	90%	110	64	92	56
	100%	98	56	77	52
Internal Battery + 3 External Battery Cabinet (minutes)	5%	1174	1001	—	—
	10%	1001	655	—	590
	20%	565	409	493	300
	30%	409	283	283	240
	40%	305	257	266	213
	50%	274	209	222	168
	60%	248	166	185	144
	70%	209	136	156	129
	80%	188	125	141	116
	90%	145	110	131	101
	100%	136	95	120	88
Internal Battery + 4 External Battery Cabinet (minutes)	5%	—	1174	—	—
	10%	1174	828	—	—
	20%	828	565	590	444
	30%	513	357	395	283
	40%	461	292	300	266
	50%	305	257	274	222
	60%	283	230	240	179
	70%	257	188	203	150
	80%	239	156	173	139
	90%	209	136	156	129
	100%	188	125	144	118

**NOTE**

Approximate discharge times are in minutes and at 25°C (77°F) with resistive load.

PowerSure PSI™

USER MANUAL

The Company Behind the Products

With over a million installations around the globe, Liebert is the world leader in computer protection systems. Since its founding in 1965, Liebert has developed a complete range of support and protection systems for sensitive electronics:

- Environmental systems—close-control air conditioning from 1 to 60 tons
- Power conditioning and UPS with power ranges from 300 VA to more than 1000 kVA
- Integrated systems that provide both environmental and power protection in a single, flexible package
- Monitoring and control—from systems of any size or location, on-site or remote
- Service and support through more than 100 service centers around the world and a 24/7 Customer Response Center

While every precaution has been taken to ensure the accuracy and completeness of this literature, Liebert Corporation assumes no responsibility and disclaims all liability for damages resulting from use of this information or for any errors or omissions.

© 2003 Liebert Corporation

All rights reserved throughout the world. Specifications subject to change without notice.

® Liebert and the Liebert logo are registered trademarks of Liebert Corporation. All names referred to are trademarks or registered trademarks of their respective owners.

SLI-23290 (3/04) Rev. 1

Technical Support/Service

Web Site

www.liebert.com

Monitoring

800-222-5877

monitoring@liebert.com

Outside the US: 614-841-6755

Single-Phase UPS

800-222-5877

upstech@liebert.com

Outside the US: 614-841-6755

Three-Phase UPS

800-543-2378

powertech@liebert.com

Environmental Systems

800-543-2778

Outside the United States

614-888-0246

Locations

United States

1050 Dearborn Drive

P.O. Box 29186

Columbus, OH 43229

Italy

Via Leonardo Da Vinci 8

Zona Industriale Tognana

35028 Piove Di Sacco (PD)

+39 049 9719 111

Fax: +39 049 5841 257

Asia

23F, Allied Kajima Bldg.

138 Gloucester Road

Wanchai

Hong Kong

+852 2 572 2201

Fax: +852 2 831 0114

Free Manuals Download Website

<http://myh66.com>

<http://usermanuals.us>

<http://www.somanuals.com>

<http://www.4manuals.cc>

<http://www.manual-lib.com>

<http://www.404manual.com>

<http://www.luxmanual.com>

<http://aubethermostatmanual.com>

Golf course search by state

<http://golfingnear.com>

Email search by domain

<http://emailbydomain.com>

Auto manuals search

<http://auto.somanuals.com>

TV manuals search

<http://tv.somanuals.com>