

LIEBHERR

Use and Care Manual

Commercial freezer

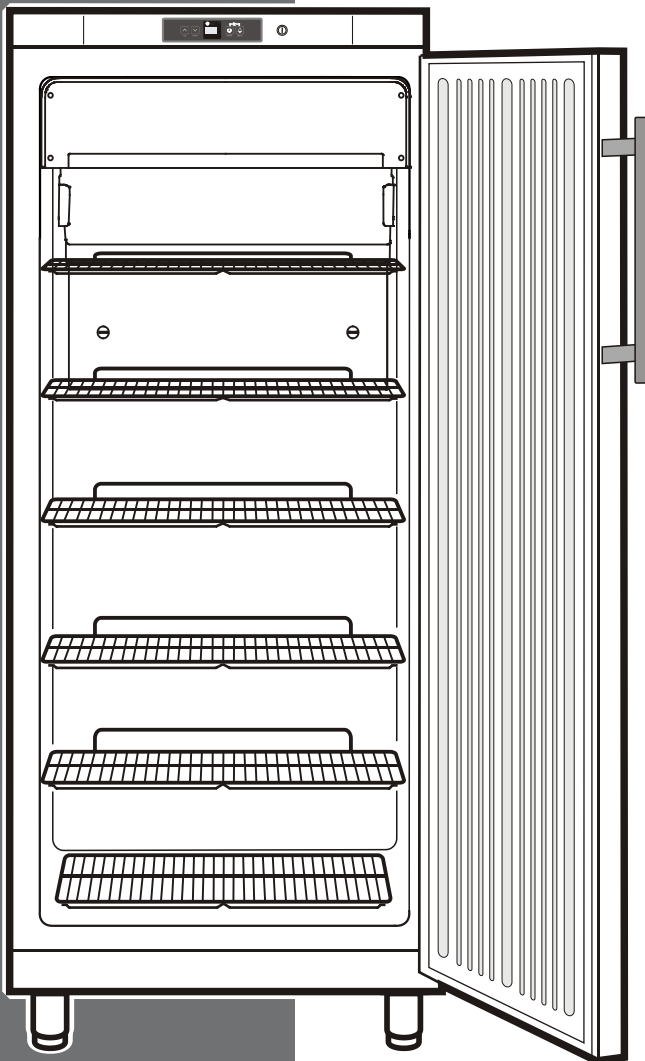

GGv
7082 213-00

IMPORTANT

PLEASE READ AND FOLLOW THESE INSTRUCTIONS

These instructions contain Danger, Warning and Caution statements. This information is important for safe and efficient installation and operation.

Always read and follow all Danger, Warning and Caution statements!

DANGER

Danger indicates a hazard which will cause serious injury or death if precautions are not followed.

WARNING

Warning indicates a potentially hazardous situation which, if not avoided, could result in death or serious injury.

CAUTION

Caution indicates a potentially hazardous situation which, if not avoided, may result in minor or moderate injury.

IMPORTANT

This highlights information that is especially relevant to a problem-free installation and operation.

Make sure incoming voltage is the same as the appliance rating.

To reduce the risk of fire, electric shock, or personal injury, installation work and electrical wiring must be done by a qualified electrician in accordance with all applicable codes and standards, including fire-rated construction.

IMPORTANT

All types and models are subject to continuous improvement. The manufacturer reserves the right to make modifications into the shape, equipment and technology.

TABLE OF CONTENTS

Keep these operating instructions in a safe place and pass them on to the next owner, where applicable.

Contents	Page
Safety	4
Disposal of Old Appliance	4
Important Safety Information	4
Electrical Safety	5
Safety Regulations.....	5
Unpacking	6
Safety Instructions and Warnings.....	6
Disposal of Carton	6
Installation	7
Dimensions	7
Component Description	7
Reversing the Door Hinges	8
Equipment.....	9
Operation.....	10
Operating and Control Elements.....	10
Turning the Appliance On and Off.....	10
Setting the Temperature.....	10
Additional Functions	11
Audible Warning Signal.....	11
Defrosting/Cleaning	12
Defrosting.....	12
Cleaning.....	12
Troubleshooting.....	13
Customer Service	13
Appliance Information.....	13

SAFETY

Disposal of Old Appliance

Be sure to follow your local requirements for disposal of appliances. Discarded appliances can be dangerous.



Risk of child entrapment. Before you discard old appliances:

- **Be sure to follow your local requirements for disposal of appliances. Discarded appliances can be dangerous.**
- **Remove the door.**
- **Leave the shelves in place so that children may not easily climb inside.**
- **Cut off the prongs from the power cable plug and discard them.**
- **Cut off the power cable from the discarded refrigerator. Discard separately from the refrigerator.**

Following these instructions reduces the possibility of causing personal injury, especially to children playing.

Contact the trash collection agency in your area for additional information.

Important Safety Information

Use the appliance only for its intended purpose - the storage of food products. Follow the cautions and safety warnings throughout this instruction manual including the following:

- To prevent injury to you or damage to the unit, the appliance should be unpacked and set up by two people.
- If the appliance is damaged on delivery, contact the supplier immediately before connecting to the power source.
- To guarantee safe operation, ensure that appliance is set up and connected as described in these operating instructions.
- Disconnect the appliance from the power source if a fault occurs. Pull out the plug, turn off or disable the power source.
- When disconnecting the appliance, use the plug. Do not pull on the cable.

- Any repairs and work on the appliance should only be performed by the customer service department. Unauthorized work may be dangerous to the user. Changing the power source cable should only be done by the customer service department.
- Do not store explosives or sprays using combustible propellants such as butane, propane, pentane in the appliance. Electrical components might cause leaking gas to ignite. You may identify such sprays by the printed contents or a flame symbol.
- Do not use electrical appliances inside the appliance.
- Do not allow children to play with the appliance. Children must not climb, sit or stand on the racks or door.
- To prevent possible injury due to an electrical shock, be sure to disconnect the power cord or turn off the circuit breaker before cleaning the appliance.
- To avoid injury or damage to the appliance, do not use steam cleaning equipment to clean the appliance.
- Do not operate the appliance in the presence of explosive fumes.
- In the event of a power outage, minimize opening the door.
- To protect the appliance from possible damage, allow the appliance to stand 1/2 to 1 hour in place before turning the electricity on. This allows the refrigerant and system lubrication to reach equilibrium.

Electrical Safety

Connect this appliance to a 110-120 VAC, 15 amp circuit that is controlled by a circuit breaker or fuse. This appliance should have its own separate grounded circuit. Do not use an extension cord.

The power cord is equipped with a three-prong (grounding) plug for your protection against possible shock hazards. To maintain this protection:

- Do not modify the plug by removing the round grounding prong.
- Do not use a two-prong adapter. Where a two-prong wall receptacle is encountered, contact a qualified electrician and have it replaced with a three-prong receptacle in accordance with all local codes and ordinances.
- Do not use a power cord that is frayed or damaged.
- To prevent the appliance from being turned off accidentally, do not plug the appliance into an outlet controlled by a wall switch.

Safety Regulations

The appliance is set to operate within specific ambient temperature limits according to its climate rating. These temperature limits should not be exceeded. The correct climate rating for your appliance is indicated on the model plate.

This is explained as follows:

Climate Rating	Set for Ambient Temperatures of
SN	50°F to 90°F (10°C to 32°C)
SN-T	50°F to 109°F (10°C to 43°C)
N	61°F to 90°F (16°C to 32°C)
ST	61°F to 100°F (16°C to 38°C)
T	61°F to 109°F (16°C to 43°C)

- The refrigerant circuit has been tested for leaks.
- The appliance complies with current safety regulations UL471 and CSA C22.2 #120-M91.

We recommend cleaning the appliance before turning it on for the first time. See **Cleaning**. Turn on the appliance several hours before loading it.



WARNING

Do not allow children to play with the appliance. Children must not climb, sit or stand on the racks or door. Failure to follow these instructions may result in death or serious injury.

UNPACKING

Safety Instructions and Warnings

CAUTION

To avoid risk of personal injury or property damage, have two people unpack and move this appliance into place.

CAUTION

Protect the finished floor surface before you uncrate the appliance.

Avoid placing the appliance in direct sunlight or near the stove, range top, radiators and similar heat sources. Do not place microwave ovens, toaster ovens or other heat-emitting appliances on top of this appliance.

The floor under the appliance should be flat and level.

The appliance is not intended for outdoor use. The ventilation grilles should not be obstructed. Always ensure there is good ventilation all around the appliance.

As soon as you uncrate the appliance:

- Examine the appliance and packaging for shipping damage. Contact the carrier immediately if you suspect there is any damage.
- Note the type (model number), index, serial number, date of purchase and where purchased on the spaces provided in the back of this manual.

Disposal of Carton

The packaging is designed to protect the appliance and individual components during moving and is made of recyclable materials:

- Corrugated board/cardboard
- Molded polystyrene (foamed, CFC-free polystyrene)
- Polythene bags and sheets
- Polypropylene straps

WARNING

Keep packaging materials away from children. Polythene sheets and bags can cause suffocation!

Please take the packaging material to your local recycling facility.

INSTALLATION

Dimensions - Figure 1

The stated total appliance height will be reached, when feet are adjusted to the lowest possible position.

GGV 5010 H = 73-3/8" (1864 mm)

GGV 5810 H = 81-1/4" (2064 mm)

The overall height of the appliance can be increased by 1-1/4" (32 mm) by turning the lower part of the adjusting feet.

⚠ WARNING

Do not adjust the feet over a height of 7-1/4" (184 mm). The lower part of the feet could get loose and the appliance could tilt.

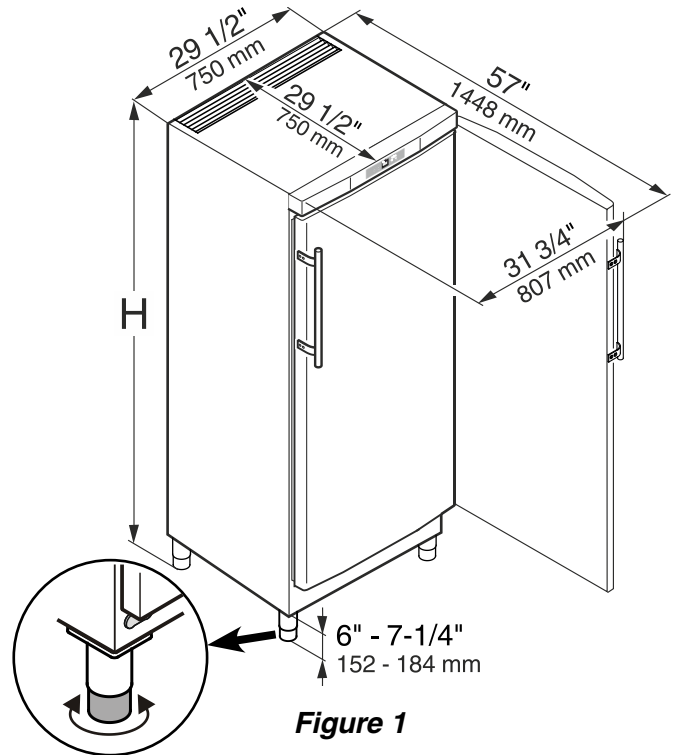

Figure 1

Component Description - Figure 2



Operating and control elements

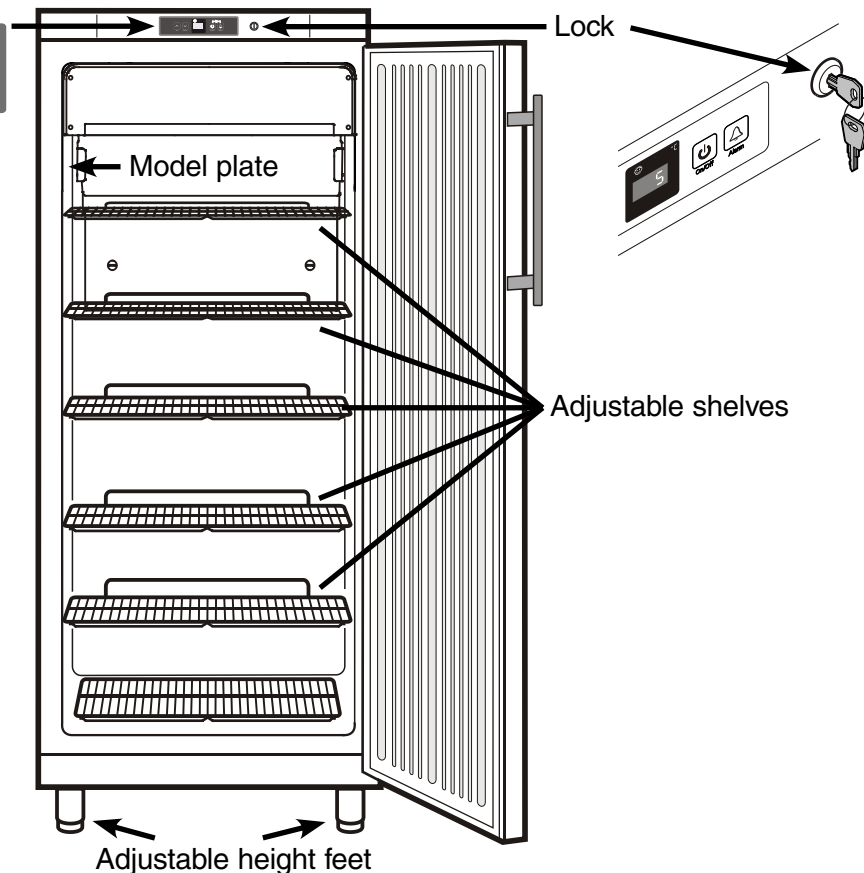

Figure 2

INSTALLATION

Reversing the Door Hinges

 **WARNING**

**For professional installer or servicer only
– a minimum of two people are required!**

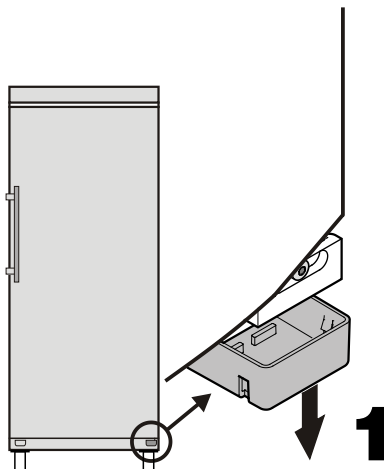

1.
Remove cover.

2.
Remove screw from lower hinge bracket.

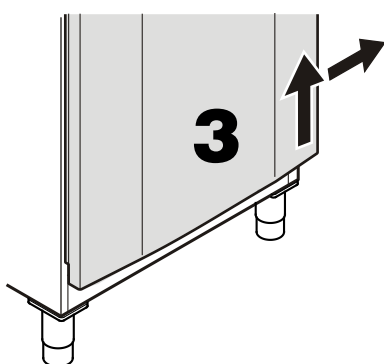
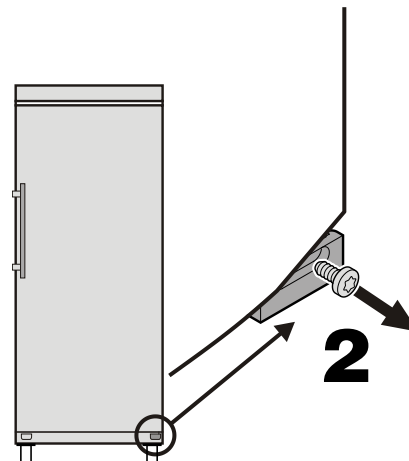

3.
Lift door, tilt to the right and remove.

4.
Turn lower hinge pin through 180° and remove.

5.
Insert pin on the opposite side and turn through 180°.

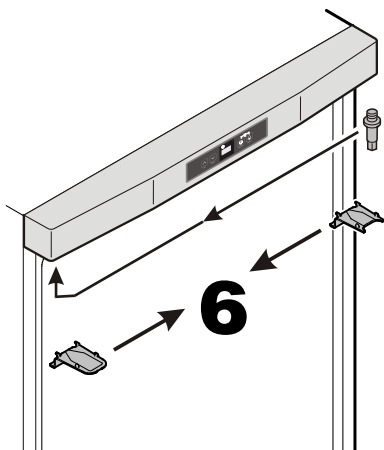
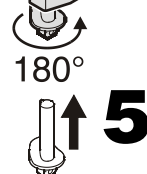
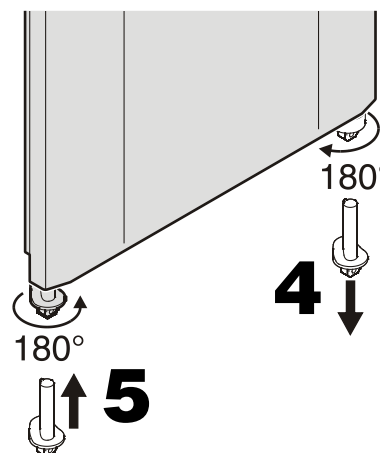

6.
Transfer upper hinge components to the opposite side.

7.
Remove cover.

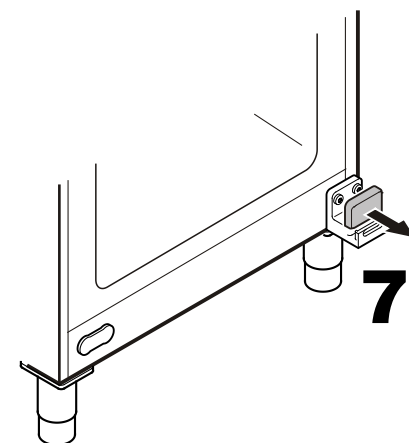

INSTALLATION

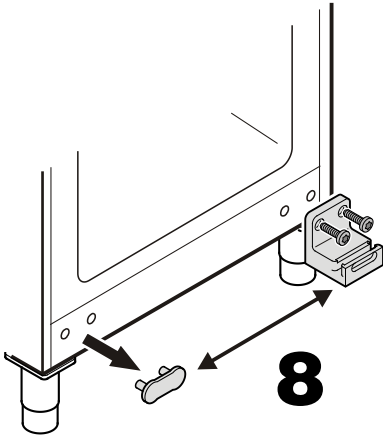

8.
Transfer lower hinge bracket and cover to the opposite side.

9.
Click cover into place.

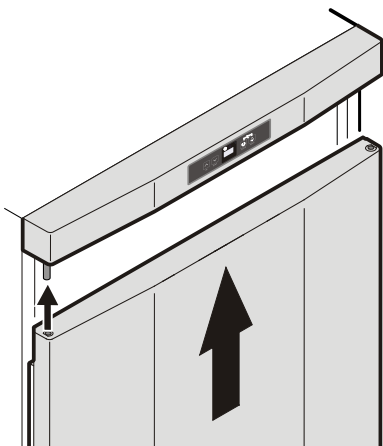
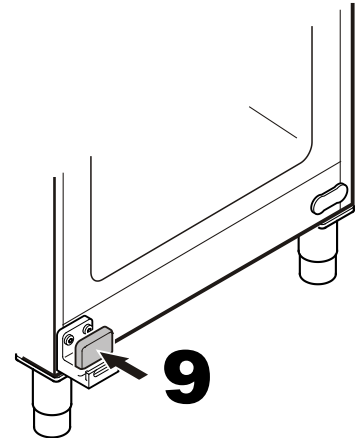

10.
Locate door to upper pin.

11.
Tilt door inwards from the left.

12.
Secure hinge pin with screw.

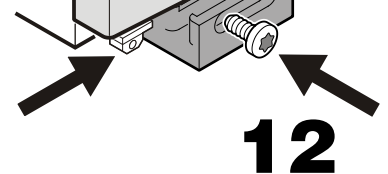
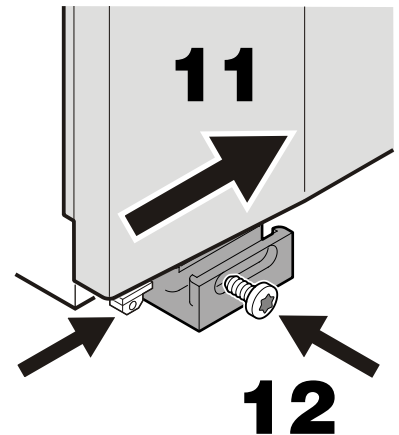

10

12

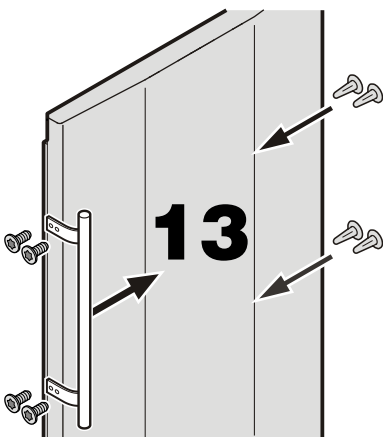

13.
Transfer handle and plugs to the opposite side.

14.
Click cover into place.

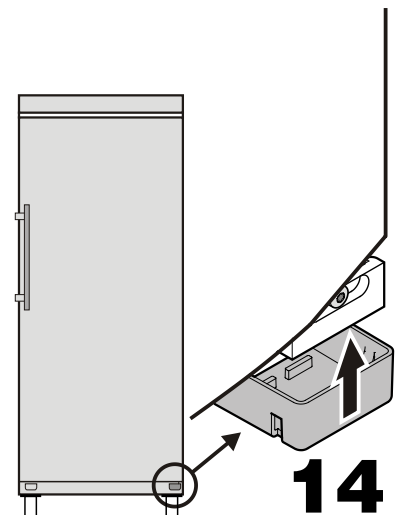

14

EQUIPMENT

Equipment - Figure 4

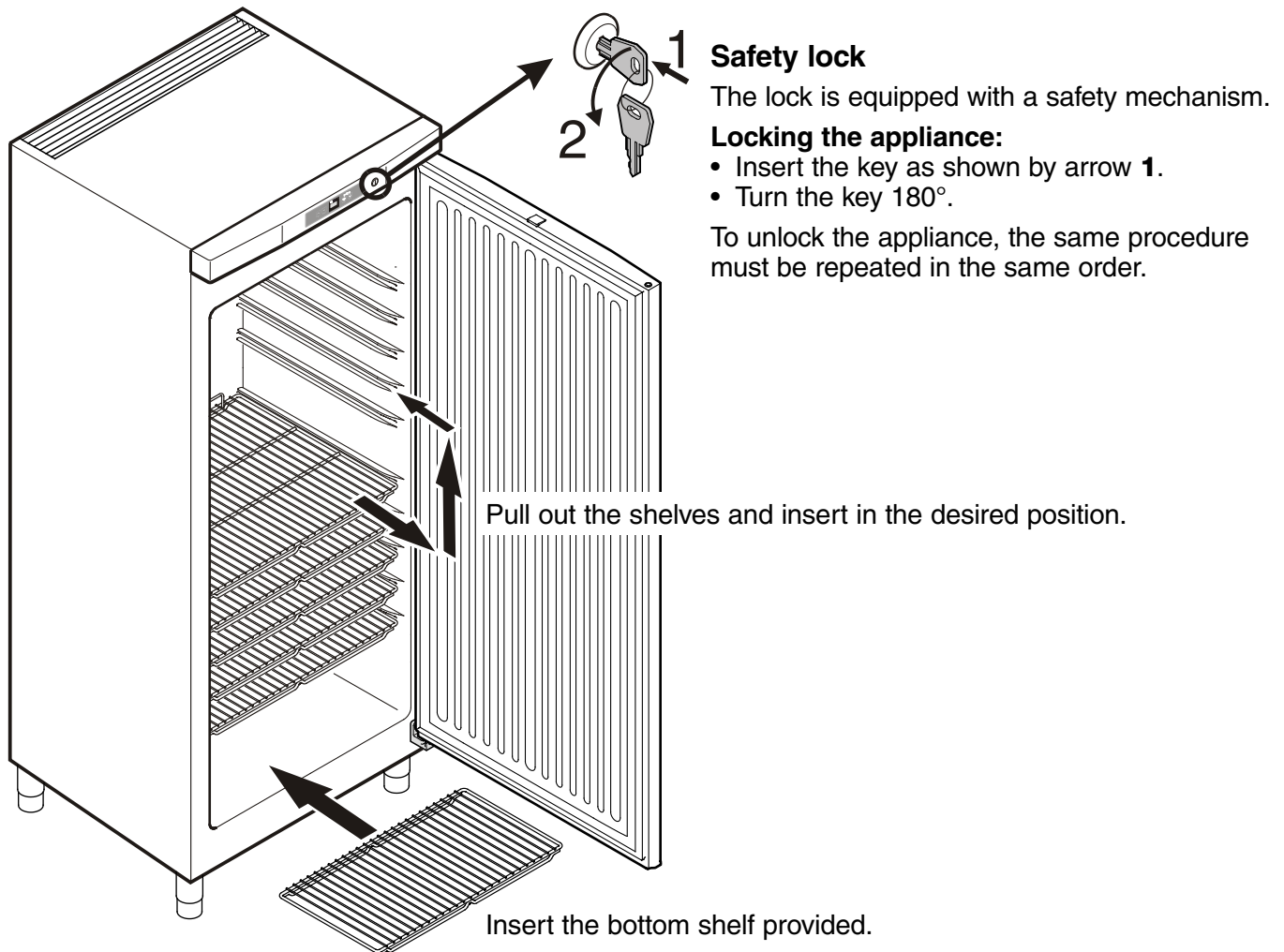

Figure 4

Operating and Control Elements - Figure 5

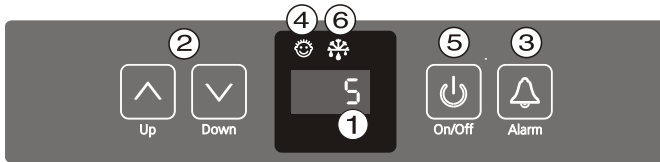

Figure 5

- ① Temperature display
- ② Temperature setting buttons
- ③ Alarm Off button
- ④ Childproof lock symbol
- ⑤ On/Off button
- ⑥ Appliance is defrosting

Turning the Appliance On and Off - Figure 6

Clean the appliance before turning it on for the first time. See **Cleaning**.

Connect the appliance to the dedicated outlet.

- **To turn the appliance on:** Press the **On/Off** button until the display lights up.
- **To turn the appliance off:** Keep the **On/Off** button pressed for three seconds so that the temperature display goes out.



Figure 6

Setting the Temperature - Figure 7

To reduce the temperature: Press the **Down** button.

To increase the temperature: Press the **Up** button.

- While you are entering the temperature, the set temperature will flash on the display.
- You can change the settings in increments of 1°F (1°C) by briefly pressing the button again. The electronic controls will switch over automatically about five seconds after the last time you pressed the button. The actual temperature will display.

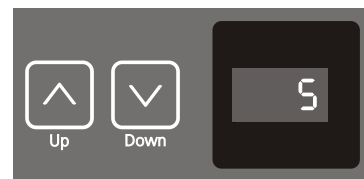

Figure 7

If F3, F4 or HE appears in the display, the appliance has a fault. Contact your nearest customer service representative.

Audible Warning Signal - Figure 8

- The audible warning signal sounds when the door is open for longer than about 180 seconds. The audible warning device is turned off by pressing the **Alarm** button.
- The audible warning signal sounds when the interior gets too warm. The temperature display will also flash. The audible warning device is turned off by pressing the **Alarm** button. The temperature display will continue to flash until the cause of the alarm has been rectified.

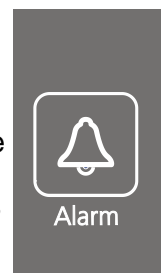



Figure 8

OPERATION



Additional functions



The keypad lock ensures that no unintentional changes are made to the electronic control system.

Activating the keypad lock

Press  for 5 seconds. Display = 



 Display = 



 Display = 



 Display = 



 Display = 



Deactivating the keypad lock

Press  for 5 seconds. Display = 



 Display = 



 Display = 



 Display = 



 Display = 

Adjusting the display brightness

Press  for 5 seconds. Display = 



 Display = 

 Display = 

Use buttons  and  to select the desired setting.

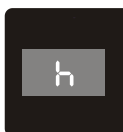
h1 = minimum brightness
h5 = maximum brightness

 Display = 

 Display = 



The adjusted brightness will be activated after one minute.

Note: If a button is pressed, the display lights up for one minute at maximum brightness.



Temperature display mode



You can choose the **unit of temperature** for the display in degrees Fahrenheit or degrees Celsius.



How to change the temperature display to degrees Celsius

Press  for 5 seconds. Display = 

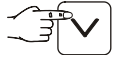

 Display = 

 Display = 

 Display = 

 Display = 

 Display = 

 Display = 

Note



To change the temperature display back to degrees Fahrenheit, follow the steps above.



Defrosting



The No-frost system automatically defrosts the freezer compartment. Any moisture will collect on the evaporator and freeze. It will periodically defrost and evaporate.

Activating the defrost function manually

If the door has been left slightly open for a long time, a layer of ice may form in the interior and on the cooling plate. The defrost function can then be activated manually.

Press  for 5 seconds. Display = 

 Display = 

 Display = 

Once the appliance is defrosted, the appliance will switch back to normal mode automatically.

CLEANING

Cleaning



WARNING

- To prevent possible injury due to an electrical shock, be sure to disconnect the power cord or turn off the circuit breaker before cleaning the appliance.
- To avoid injury or damage, do not use steam cleaning equipment to clean the appliance.

Clean the inside and equipment by hand with lukewarm water and a little detergent.

Do not use abrasive or scouring sponges. Do not use concentrated cleaning agents. Never use abrasive or acid cleaners or chemical solvents or steam cleaners.

- Ensure no cleaning water penetrates into the electrical components or ventilation grille.
- Dry all parts well with a cloth.
- Do not damage or remove the model plate on the inside of the appliance. It is very important for servicing your appliance.

Remove any dust from the outside of the ventilation grille (**Figure 13**) with a vacuum cleaner.

Ventilation grille

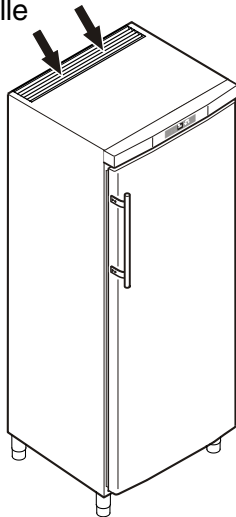

Figure 13

Keep your stainless steel looking new by cleaning with a good-quality stainless steel cleaner or polish monthly. High-quality stainless steel cleaners and conditioners are commercially available.

Do not clean with steel wool pads or abrasive pads. Do not use cleaners that are not for use on stainless steel, such as glass cleaners, tile cleaners or cleaners used to clean counter tops. These types of cleaners can damage the surface permanently.

Stainless steel that is exposed to chlorine gas and moisture may have some discoloration. This discoloration is normal. If your appliance is used in this environment, clean and polish your stainless steel more often.

If the surface discolors or rusting appears, clean it quickly with a nonabrasive cloth and protect it. Always clean and polish in the direction of the grain and finish.

TROUBLESHOOTING

Your appliance is designed and manufactured for a long life and reliable operation.

If a problem occurs during operation, check whether it is due to an operating error. Please note that even during the warranty period, some repair costs may be your responsibility.

You may be able to correct the following faults by checking the possible causes yourself:

Problem	Possible Cause and Remedy
Appliance does not work; display is off	<ul style="list-style-type: none"> - Is the appliance turned on properly? - Is the power cord properly inserted in the outlet? - Is the circuit breaker or fuse in operating condition?
Loud running noise	<ul style="list-style-type: none"> - Is the appliance placed firmly on the floor, or does the compressor cause nearby items of furniture or objects to vibrate?
Motor seems to run too long	<ul style="list-style-type: none"> - Is the ambient temperature too hot? See Safety Regulations. - Has the appliance been opened too often or left open too long?
The temperature is not cold enough	<ul style="list-style-type: none"> - Is the temperature setting correct? See Setting the Temperature. - Has an excessive amount of fresh food been placed in the appliance? - Does a separately installed thermometer show the correct reading? - Is the ventilation system working properly? - Is the appliance set up too close to a heat source?
F3, F4 or HE appears in the display	The appliance has a fault. Contact your nearest customer service representative, indicate the type of appliance, index and appliance/serial number.
Ad appears in the display	Manually activate the defrost function once. See section entitled "Activating the defrost function manually" - page 13. If Ad continues to be displayed once defrosting has finished, the appliance has a fault. In this case, contact the customer service representative.

Customer Service

If none of the above possible causes apply, and you cannot rectify the fault yourself, contact your nearest customer service representative. Indicate the type **(1)** of appliance, service number **(2)** and the appliance/serial number **(3)** as indicated on the model plate. The model plate is located on the left-hand inside wall.

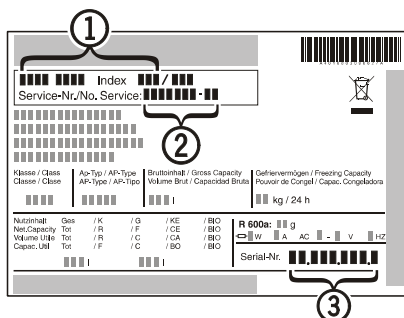

Appliance Information

Record this information when the appliance is installed.

Type Designation: _____

Service Number: _____

Appliance/Serial Number: _____

Date of Purchase: _____

Where Purchased: _____

WARRANTY

LIEBHERR WARRANTY PLAN

FULL ONE YEAR WARRANTY - For one year from the date of original purchase, your Liebherr warranty covers all parts and labor to repair or replace any part of the product which proves to be defective in materials or workmanship.

FULL FIVE YEAR WARRANTY - For five years from the date of original purchase, your Liebherr warranty covers all parts and labor to repair or replace any components that prove to be defective in materials or workmanship in the sealed system. The "Sealed System" means only the compressor, condenser, evaporator, drier and all connecting tubing.

TERMS APPLICABLE TO EACH WARRANTY

All service provided by Liebherr under the warranty must be performed by authorized Liebherr service representatives, unless otherwise specified by Liebherr. Service will be provided in the customer's place of business during normal business hours. This warranty applies only to products installed for intended application for commercial use.

The warranty applies only to products installed in Canada and any one of the fifty States of the United States or the District of Columbia. This warranty does not cover any parts or labor to correct any defect caused by negligence, accident or improper use, maintenance, installation, service or repair, including but not limited to improper removal and reinstallation of the condensing unit.

THE WARRANTIES DESCRIBED ABOVE ARE MADE EXPRESSLY IN LIEU OF ANY OTHER WARRANTIES, EXPRESSED OR IMPLIED, INCLUDING ANY IMPLIED WARRANTY OF MERCHANTABILITY OR FITNESS FOR A PARTICULAR PURPOSE, AND OF ANY OTHER OBLIGATION OR LIABILITY ON THE PART OF LIEBHERR. IN NO EVENT SHALL LIEBHERR BE LIABLE FOR SPECIAL, INCIDENTAL OR CONSEQUENTIAL DAMAGES ARISING FROM THE BREACH OF THESE WARRANTIES OR ANY OTHER WARRANTIES, WHETHER EXPRESS, IMPLIED OR STATUTORY.

Some states do not allow the exclusion or limitation of incidental or consequential damages so the above limitation or exclusion may not apply to you. This warranty gives you specific legal rights and you may also have other rights which vary from State to State.

To receive parts and/or service and the name of the Liebherr authorized service representative nearest you, contact your Liebherr dealer or distributor or contact the Liebherr designated national service provider:

in the US: sales@dellfrio.com, or call +1-864-591-33-04

in Canada: info.lca@liebherr.com, or call +1-905-319-92-22

Free Manuals Download Website

<http://myh66.com>

<http://usermanuals.us>

<http://www.somanuals.com>

<http://www.4manuals.cc>

<http://www.manual-lib.com>

<http://www.404manual.com>

<http://www.luxmanual.com>

<http://aubethermostatmanual.com>

Golf course search by state

<http://golfingnear.com>

Email search by domain

<http://emailbydomain.com>

Auto manuals search

<http://auto.somanuals.com>

TV manuals search

<http://tv.somanuals.com>