

95C Inclusive Upright Lifecycle[®] Exercise Bike Base

Owners Manual
05/19/10 M051-00K67-B148



inclusive fitness
accredited item
2007-2012

LifeFitness
WHAT WE LIVE FOR

CORPORATE HEADQUARTERS

5100 River Road
Schiller Park, Illinois 60176 • U.S.A.
847.288.3300 • FAX: 847.288.3703
800.735.3867 (Toll-free within U.S.A., Canada)
Global Website: www.lifefitness.com

INTERNATIONAL OFFICES

AMERICAS

North America Life Fitness Inc.

5100 N River Road
Schiller Park, IL 60176 U.S.A
Telephone: (847) 288 3300
Fax: (847) 288 3703
Service Email: commercialservicereply@lifefitness.com
Sales/Marketing Email: commercialsales@lifefitness.com
Operating Hours: 7:00 am-6:00 pm (CST)

Brazil

Life Fitness Brasil

Av. Cidade Jardim, 900
Jd. Paulistano
São Paulo, SP 01454-000
BRAZIL
SAC: 0800 773 8282
Telephone: +55 (11) 3095 5200
Fax: +55 (11) 3095 5201
Service Email: suporte@lifefitness.com.br
Sales/Marketing Email: lifefitness@lifefitness.com.br
Service Operating Hours:
9:00 - 17:00 (BRT) (Monday-Friday)
Store Operating Hours:
9:00 -20:00 (BRT) (Monday-Friday)
10:00 - 16:00 (BRT) (Saturday)

Latin America & Caribbean*

Life Fitness Inc.

5100 N River Road
Schiller Park, IL 60176 U.S.A
Telephone: (847) 288 3300
Fax: (847) 288 3703
Service Email: customersupport@lifefitness.com
Sales/Marketing Email: commercialsales@lifefitness.com
Operating Hours: 7:00am-6:00pm (CST)

EUROPE, MIDDLE EAST, & AFRICA (EMEA)

Netherlands & Luxemburg

Life Fitness Atlantic BV

Bijdorplein 25-31
2992 LB Barendrecht
THE NETHERLANDS
Telephone: (+31) 180 646 666
Fax: (+31) 180 646 699
Service Email: service.benelux@lifefitness.com
Sales/Marketing Email:
marketing.benelux@lifefitness.com
Operating Hours: 9.00h-17.00h (CET)

United Kingdom & Ireland

Life Fitness UK LTD

Queen Adelaide
Ely, Cambs, CB7 4UB
Telephone: General Office (+44) 1353.666017
Customer Support (+44) 1353.665507
Fax: (+44) 1353.666018
Service Email: uk.support@lifefitness.com
Sales/Marketing Email: life@lifefitness.com
Operating Hours:
General Office: 9.00am - 5.00pm (GMT)
Customer Support: 8.30am - 5.00pm (GMT)

Germany & Switzerland

Life Fitness Europe GMBH

Siemensstraße 3
85716 Unterschleißheim
GERMANY
Telephone: (+49) 89.31 77 51.0 (Germany)
(+41) 0848 000 901 (Switzerland)
Fax: (+49) 89.31 77 51.99 (Germany)
(+41) 043 818 07 20 (Switzerland)
Service Email: kundendienst@lifefitness.com
Sales/Marketing Email: kundenberatung@lifefitness.com
Operating Hours: 08.30 -16.30h (CET)

Austria

Life Fitness Austria

Vertriebs G.m.b.H.
Dückerstraße 7-9/3/36
1220 Vienna
AUSTRIA
Telephone: (+43) 1.61.57.198
Fax: (+43) 1.61.57.198.20
Service Email: kundendienst@lifefitness.com
Marketing/Sales Email: kundenberatung@lifefitness.com
Operating Hours: 9.00h-17.00h (MEZ)

Spain

Life Fitness IBERIA

C/Frederic Mompou 5,1ªª
08960 Sant Just Desvern Barcelona
SPAIN
Telephone: (+34) 93.672.4660
Fax: (+34) 93.672.4670
Service Email: info.iberia@lifefitness.com
Sales/Marketing Email: info.iberia@lifefitness.com
Operating Hours:
9.00h-18.00h (Monday-Thursday)
8.30h-15.00h (Friday)

Belgium

Life Fitness Benelux NV

Parc Industriel de Petit-Rechain
4800 Verviers
BELGIUM
Telephone: (+32) 87 300 942
Fax: (+32) 87 300 943
Service Email:
internationalservicesupport@lifefitness.com
Sales/Marketing Email:
marketing.benelux@lifefitness.com
Operating Hours: 9.00h -17.00h (CET)

Italy

Life Fitness Europe GmbH

Siemensstraße 3
85716 Unterschleißheim
GERMANY
Telephone: (+39) 02-55378611
Service: 800438836 (In Italy)
Fax: (+39) 02-55378699
Service Email: assistentatecnica@lifefitness.com
Sales/Marketing Email: info@lifefitnessitalia.com
Operating Hours: 08:30 - 16:30h (CET)

All Other EMEA countries & distributor business C-EMEA*

Bijdorplein 25-31
2992 LB Barendrecht
THE NETHERLANDS
Telephone: (+31) 180 646 644
Fax: (+31) 180 646 699
Service Email: service.db.cemea@lifefitness.com
Sales/Marketing Email:
marketing.db.cemea@lifefitness.com
Operating Hours: 9.00h-17.00h (CET)

ASIA PACIFIC (AP)

Japan

Life Fitness Japan

Nippon Brunswick Bldg., #8F
5-27-7 Sendagaya
Shibuya-Ku, Tokyo
Japan 151-0051
Telephone: (+81) 3.3359.4309
Fax: (+81) 3.3359.4307
Service Email: service@lifefitnessjapan.com
Sales/Marketing Email: sales@lifefitnessjapan.com
Operating Hours: 9.00h-17.00h (JAPAN)

China and Hong Kong

Life Fitness Asia Pacific LTD

Room 2610, Miramar Tower
132 Nathan Road
Tsimshatsui, Kowloon
HONG KONG
Telephone: (+852) 2891.6677
Fax: (+852) 2575.6001
Service Email: HongKongEnquiry@lifefitness.com
Sales/Marketing Email: ChinaEnquiry@lifefitness.com
Operating Hours: 9.00h-18.00h

All Other Asia Pacific countries & distributor business Asia Pacific*

Room 2610, Miramar Tower
132 Nathan Road
Tsimshatsui, Kowloon
HONG KONG
Telephone: (+852) 2891.6677
Fax: (+852) 2575.6001
Service Email: HongKongEnquiry@lifefitness.com
Sales/Marketing Email: ChinaEnquiry@lifefitness.com
Operating Hours: 9.00h-18.00h

* Also check www.lifefitness.com for local representation or distributor/dealer.

Before using this product, it is essential that this ENTIRE operation manual and ALL installation instructions be read.

This will help in setting up the equipment quickly and in instructing others on how to use it correctly and safely.

Class I (Inclusive): Professional and / or commercial use.



CAUTION: Any changes or modifications to this equipment could void the product warranty.

Any service, other than cleaning or user maintenance, must be performed by an authorized service representative. There are no user serviceable parts.

Table of Contents

Section	Description	Page
1.	Getting Started	5
1.1.	Important Safety Instructions	5
1.2.	Setup	6
	Electrical Power Requirements // Where to Place the Inclusive Upright Lifecycle® Exercise Bike // How to Stabilize the Inclusive Upright Lifecycle Exercise Bike // Check for Battery Power // External Power // How to Adjust the Seat // How to Adjust the Pedal Straps	
2.	Service and Technical Data	9
2.1	Preventive Maintenance Tips	9
2.2	Preventive Maintenance Schedule	9
2.3	Troubleshooting the Polar® Heart Rate Chest Strap	10
	Heart Rate Reading is Erratic, Absent Entirely, or Abnormally Elevated	
2.4	Troubleshooting the Lifepulse™ System Sensors	12
2.5	Recycling the Battery	12
2.6	How to Obtain Product Service	12
3	Specifications	13
3.1	95C Inclusive Upright Lifecycle® Exercise Bike Base Specifications	13

© 2010 Life Fitness, a division of Brunswick Corporation. All rights reserved. Life Fitness, a division of Brunswick Corporation. All rights reserved. Life Fitness, Heart Rate Zone Training, and Lifepulse are registered trademarks of Brunswick Corporation. Fit Stride, Heart Rate Zone Training+, Heart Rate Hill, Heart Rate Interval, and Extreme Heart Rate are trademarks of Brunswick Corporation. Polar is a registered trademark of Polar Electro, Inc. Cardio Theater is a registered trademark of the Cardio Theater Holdings. FitLinxx is a registered trademark of the Integrated Fitness Corp. Any use of these trademarks, without the express written consent of Life Fitness or the corresponding companies is forbidden.



This Operation Manual describes the functions of the following product:
Life Fitness 95C Inclusive Upright Lifecycle® Exercise Bike:

See "Specifications" page in this manual for product specific features.

Statement of Purpose: The Life Fitness Inclusive Upright Lifecycle Exercise Bike is a speed-independent machine that simulates the movements of riding a bicycle at various speeds and levels of resistance.

 **CAUTION: Health-related injuries may result from incorrect or excessive use of exercise equipment. Life Fitness STRONGLY recommends seeing a physician for a complete medical exam before undertaking an exercise program, particularly if the user has a family history of high blood pressure or heart disease, or is over the age of 45, or smokes, has high cholesterol, is obese, or has not exercised regularly in the past year.**

If, at any time while exercising, the user experiences faintness, dizziness, pain, or shortness of breath, he or she must stop immediately.

1 Getting Started

1.1 Important Safety Instructions



SAFETY WARNING: The safety of the product can be maintained only if it is examined regularly for damage and wear. See Preventive Maintenance section for details.

- If this Life Fitness product does not function properly after it has been dropped, damaged, or even partially immersed in water, contact Life Fitness Customer Support Services for assistance.
- Always follow the console instructions for proper operation.
- Close supervision is necessary when used by children, invalids or disabled persons.
- Do not use this product outdoors, near swimming pools or in areas of high humidity.
- Never operate a Life Fitness product with the air openings blocked. Keep air openings free of lint, hair or any obstructing material.
- Never insert objects into any opening in this product. If an object should drop inside, carefully retrieve it. If the item cannot be reached, contact Life Fitness Customer Support Services.
- Never place liquids of any type directly on the unit, except in the accessory tray water bottle holder. Containers with lids are recommended.
- Wear shoes with rubber or high-traction soles. Do not use shoes with heels, leather soles, cleats or spikes. Make sure no stones are embedded in the soles.
- Keep all loose clothing, shoelaces and towels away from moving parts.
- Do not use this product in bare feet.
- Do not tip the unit on its side during operation.
- Keep the area around the Inclusive Upright Lifecycle® Exercise Bike clear of any obstructions, including walls and furniture. Ensure that there is at least three feet of clearance behind the Inclusive Upright Lifecycle Exercise Bike.
- Use caution when mounting or dismounting the Inclusive Upright Lifecycle Exercise Bike. Use the stationary handlebar whenever additional stability is required.
- Never use the Inclusive Upright Lifecycle Exercise Bike while facing backward.

SAVE THESE INSTRUCTIONS FOR FUTURE REFERENCE.

1.2 Setup

Read the Operation Manual before setting up the Upright Lifecycle® Exercise Bike.

Electrical Power Requirements

An optional external power supply is available for the Inclusive Upright Lifecycle Exercise Bike. The external power supply requires an AC power supply according to the electrical configurations listed in the chart below.

Supply Voltage (VAC)	Frequency (Hz)	Rated Current (Amps)
100	50 / 60	1.6
110	50 / 60	1.6
120	50 / 60	1.6
200	50 / 60	.8
220	50 / 60	.8
230	50 / 60	.8
240	50 / 60	.8

NOTE: Do not modify the plug provided with this product. If the plug does not fit into an available electrical outlet, have a proper outlet installed by a qualified electrician.

Where to place the Inclusive Upright Lifecycle Exercise Bike

Following all safety instructions in Section 1.1, move the bike to the location in which it will be used. See Section 3, titled *Specifications*, for the dimensions of the product footprint (assembled dimensions). Allow a distance of 21 to 30 centimeters (8 to 12 inches) between the bike and other objects or surfaces on either side. Allow a distance of 1 meter (3 feet) from the front or rear of the bike to any other object or surface.

How to stabilize the Inclusive Upright Lifecycle Exercise Bike

After placing the bike in position, check the unit's stability by attempting to rock it from side to side. Any slight rocking indicates that the unit must be leveled. Determine which foot is not resting completely on the floor. Loosen the jam nut (A) with an open-end M17 wrench, and rotate the stabilizing foot (B) to lower it. Verify that the bike is stable, and repeat the adjustment as necessary until the unit no longer rocks. Lock the adjustment by tightening the jam nut against the stabilizer bar.

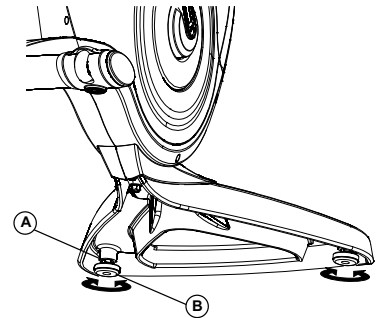

The STEP-UP PLATFORM is shipped in a configuration to be placed on the user left side of the Inclusive Upright Lifecycle® Exercise Bike (as shown). The STEP-UP PLATFORM is designed for use on either side of the Inclusive Upright Lifecycle® Exercise Bike.

If the STEP-UP PLATFORM is to be used on the user right side of the Inclusive Upright Lifecycle® Exercise Bike:

1. Remove the four SCREWS (AA) securing the STEP-UP PLATFORM (BB) to the STEP LOCATOR BRACKET (CC).
2. Flip the STEP LOCATOR BRACKET (CC), align the STEP LOCATOR BRACKET to the STEP-UP PLATFORM (BB) and secure using the four previously removed SCREWS (AA). Tighten the SCREWS securely. Do not overtighten the SCREWS.

Peel the protective liner from each of the six NON-SLIP PADS (DD) and place them on the underside of the STEP LOCATOR BRACKET (CC) as shown.

Carefully lift the rear of the Inclusive Upright Lifecycle Exercise Bike and position the STEP-UP PLATFORM under the REAR STABILIZER (EE) as shown. Be sure the REAR STABILIZER sits completely on the floor within the STEP LOCATOR BRACKET (CC).

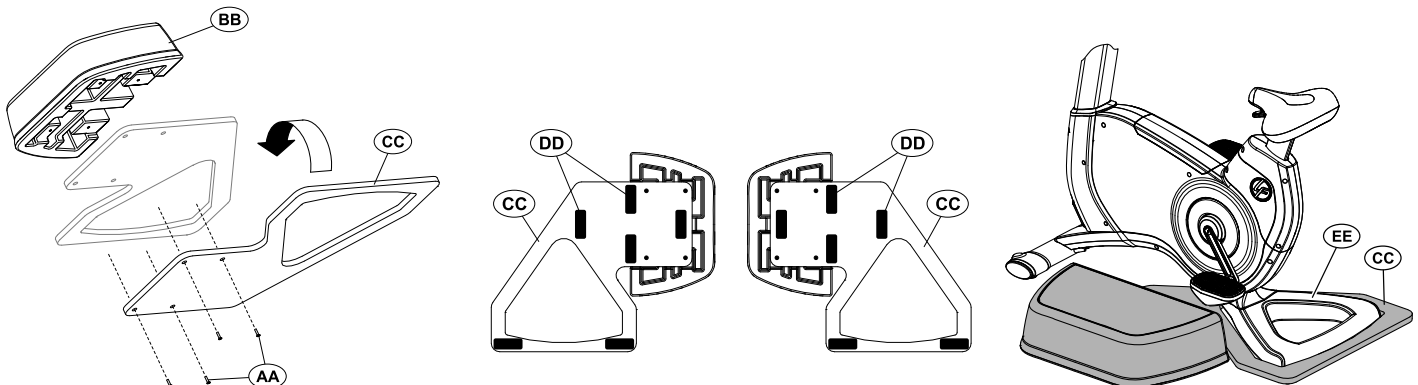

Check for Battery Power

The Inclusive Upright Lifecycle Exercise Bike console is powered by a rechargeable 6-volt battery. Check the battery by pressing and holding the power on/off  key. The console should beep and light up. The Message Center on the console will display a prompt to set up a workout. If a prompt doesn't appear or initializing doesn't begin, mount the Inclusive Upright Lifecycle Bike and begin pedaling. The console should light up and programming a workout should be possible. Pedal for 20 minutes at 40 RPM or faster during a workout to charge the battery. The pedal action during workouts keeps the battery charged. If the Inclusive Lifecycle Exercise Bike is powered by the external 36V DC power supply, battery maintenance is automatic and pedaling is not required.

External power

If using the optional external power supply, be sure to plug **the power connector to the front of the Inclusive Upright Lifecycle Bike before plugging the AC power in**. Plug the cord into an AC outlet. The console should immediately beep and light up.

NOTE: If the console does not light up, contact Life Fitness Customer Service (*refer to page one of this manual*).

The following connection receptacles are located at the front of the Inclusive Upright Lifecycle Exercise Bike: Attachable TV power (C), coaxial cable (D), external power for the Engage console or optional external power (E), and fitness networking (F).

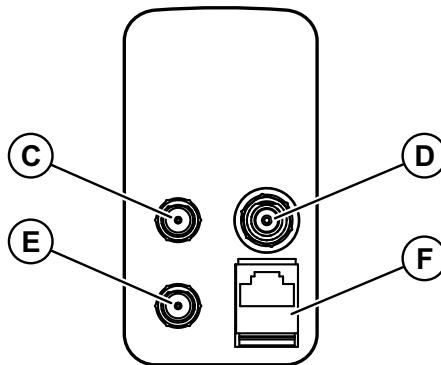

 **CAUTION:** Connectors should easily fit into the receptacles. Forcing a connection may lead to damage to the barrel connector and/or receptacle and may void product warranty.

How to Adjust the Seat

A properly adjusted seat is extremely important in any bike-oriented exercise activity and the Inclusive Upright Lifecycle Bike is no exception. If the seat is too close, excessive strain will be placed on the knees and quadriceps muscles; if the seat is too far, the resulting reaching action will irritate the feet, ankles, hips and knees.

Sit on the seat and place the balls of the feet on the pedals. An optimum position will allow movement through the bottom of the stroke without locking the knees or shifting in the seat. The knees should have a slight bend at the point of fullest leg extension.

If the seat needs to be adjusted lower, lift the spring-loaded adjusting handle (G) located underneath the nose of the seat. Hold both the handle and nose of the seat with one hand and use the other hand to grab the rear of the seat. Slide the handle and seat down to the proper position and release the pin to complete engagement. Gently slide the seat up and down a small distance to ensure it is locked into place. Check the seat distance again and re-adjust it if necessary. If the seat needs to be adjusted higher, grab the seat and slide it up to the proper position. When adjusting the seat to a higher position, the user does not have to lift the spring-loaded adjusting handle. Gently slide the seat up to the proper position.

 **CAUTION:** Do not attempt to adjust the seat while pedaling the bike or sitting on the seat. Doing so may result in an uncomfortable workout or cause injury.

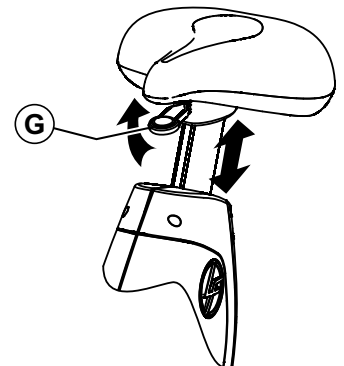

How to Adjust the Pedal Straps

The bike pedal straps keep the user's shoes on the pedals during a workout. The straps should fit comfortably, but they also should be tight enough to prevent shoes from slipping at any point in the pedaling rotation. Before working out, a user should test and adjust the tightness of the straps.

The Velcro type safety straps on the pedals of the Inclusive Recumbent Lifecycle Exercise Bike can be adjusted to fit a variety of shoe sizes. Pull the D-ring (H) upward to separate the two surfaces of the Velcro on the strap (I). Put the foot on the pedal (J) underneath the strap. Pull the strap with the D-ring to tighten the strap over the foot, then press the Velcro surfaces of the strap firmly together to ensure that the foot is securely positioned in the pedal.

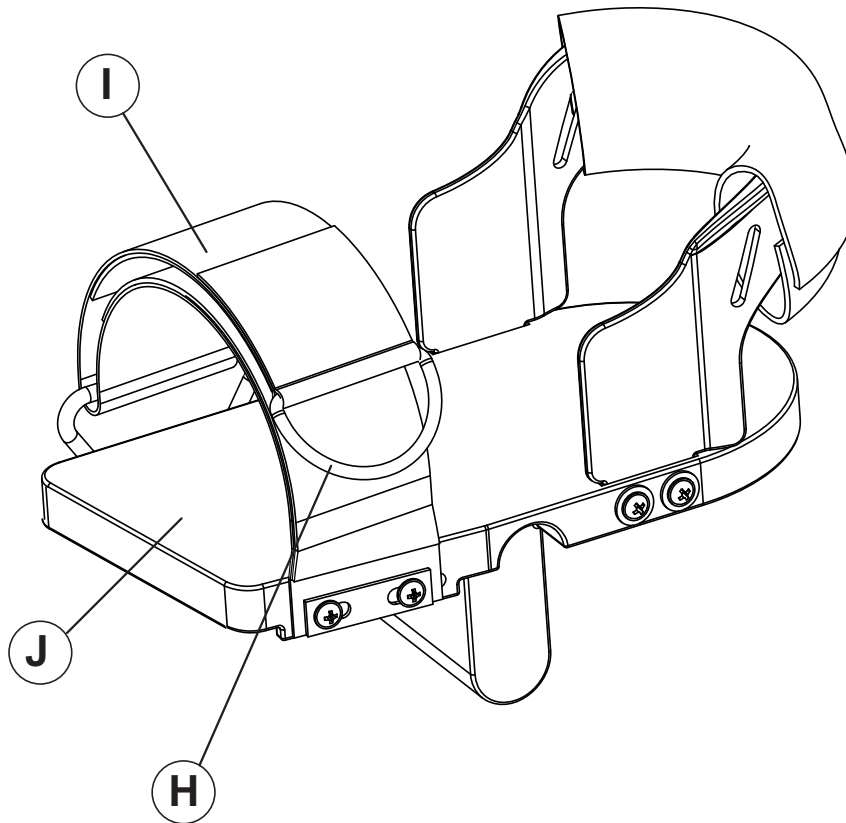

2 Service and Technical Data

2.1 Preventive Maintenance Tips

The Inclusive Upright Lifecycle Exercise Bike is backed by the engineering excellence of Life Fitness and is one of the most rugged and trouble-free pieces of exercise equipment on the market today. Commercial Life Fitness products have proven to be durable in health club, college, and military fitness facilities the world over. This same technology, engineering expertise, and reliability have gone into the Inclusive Upright Lifecycle Exercise Bike.

NOTE: The safety of the equipment can be maintained only if the equipment is examined regularly for damage or wear. Keep the equipment out of use until defective parts are repaired or replaced. Pay special attention to parts that are subject to wear as outlined in the Preventive Maintenance Schedule.

The following preventive maintenance tips will keep your Inclusive Upright Lifecycle Exercise Bike operating at peak performance:

- Locate the Inclusive Upright Lifecycle Exercise Bike in a cool, dry place.
- Keep the pedal straps fastened securely when using the bike.
- Clean the top surface of the pedals regularly.
- Use a 100% cotton cloth, lightly moistened with water and mild liquid detergent, to clean the Inclusive Upright Lifecycle Exercise Bike. Other fabrics, including paper towels, may scratch the surface. Do not use ammonia, chlorine, or acid-based cleaners.
- Clean the frame thoroughly on a regular basis.



NOTE: When cleaning the exterior of the unit, a non-abrasive cleaner and soft cotton cloth are strongly recommended. At no time should cleaner be applied directly to any part of the equipment; apply the non-abrasive cleaner on a soft cloth and then wipe the unit.

2.2 Preventive Maintenance Schedule

Follow the schedule below to ensure proper operation of the product.

ITEM	WEEKLY	MONTHLY	ANNUALLY
<i>Frame/Seat Post</i>	<i>Clean</i>		<i>Inspect</i>
<i>Pedals/Straps</i>	<i>Clean</i>	<i>Inspect</i>	
<i>Accessory Tray</i>	<i>Clean</i>	<i>Inspect</i>	
<i>Plastic Covers</i>	<i>Clean</i>	<i>Inspect</i>	

2.3 Troubleshooting the Optional Polar® Telemetry Heart Rate Chest Strap Heart Rate Reading Is Initially Detected then Lost or Abnormally Elevated

Malfunction	Probable Cause	Corrective Action
Heart rate reading is initially detected and functioning normally but then is lost.	Use of personal electronic devices, such as cell phones and portable MP3 players, causes external noise interference.	Remove the source of noise or reposition the exercise equipment.
	Equipment is in close proximity to other sources of noise such as audio/ video equipment, fans, two way radios, and high voltage/highcurrent power lines.	
Heart rate readings are abnormally elevated.	Television sets and/or antennas generate electromagnetic interference.	Move the treadmill a few inches away from the probable cause, or move the probable cause a few inches away from the treadmill, until the heart rate readings are accurate.
	Cell phones generate electromagnetic interference.	
	Computers generate electromagnetic interference.	
	Cars generate electromagnetic interference.	
	High voltage power lines generate electromagnetic interference.	
	Motor driven exercise equipment generates electromagnetic interference.	
	Another heart rate transmitter within three feet (one meter) generates electromagnetic interference.	

Troubleshooting the Optional Polar® Telemetry Heart Rate Chest Strap (CONTINUED)

Heart Rate Reading Is Erratic Or Absent Entirely

Malfunction	Probable Cause	Corrective Action
Heart rate reading is erratic or absent entirely.	Belt transmitter electrodes are not wet enough to pick up accurate heart rate readings.	Wet the belt transmitter electrodes (see Section 3.2).
	Belt transmitter electrodes are not laying flat against the skin.	Ensure the belt transmitter electrodes are laying flat against the skin (see Section 3.2).
	Belt transmitter needs cleaning.	Wash the belt transmitter with mild soap and water.
	Belt transmitter is not within 3 feet (1 meter) of the heart rate receiver.	Make sure the chest strap transmitter is within 3 feet (1 meter) of the heart rate receiver.
	Polar telemetry heart rate chest strap battery is depleted.	Contact Life Fitness Customer Support Services for instructions on how to have the Polar telemetry heart rate chest strap replaced.
	Polar telemetry heart rate chest strap did not lock in with the heart rate receiver.	<p>Make sure the Polar telemetry heart rate chest strap is installed and move closer to the heart rate receiver. Wait up to 10 seconds for the heart rate to display on the console.</p> <p>Notes:</p> <ol style="list-style-type: none"> 1. <i>Ensure proper adherence of the Polar telemetry heart rate chest strap to user's chest.</i> 2. <i>Ensure proper conductivity between the electrodes and user's chest.</i> 3. <i>If needed, use the Polar watch to verify chest strap's operation.</i>

2.4 Troubleshooting the Lifepulse System Sensors

If the heart rate reading is erratic or missing, do the following:

- Dry hands if necessary to prevent slipping.
- Apply hands to the sensors that are set into the handlebars.
- Apply constant pressure around the sensors.

2.5 Recycling the Battery

When this Life Fitness product is about to be discarded at the end of its useful life, the rechargeable battery must be removed and recycled. To access the battery, use a medium tip Phillips screw driver to remove the six screws that hold the seat post shrouds around the seat post. To remove the battery, remove the two wires connected to the battery and the two screws that hold the battery in place. Dispose of the battery properly.

2.6 How to Obtain Product Service

1. Verify the symptom and review the operating instructions. The problem may be unfamiliarity with the product and its features and workouts.
2. Locate the serial number plate, which is located on the front stabilizer. Document the serial number, which consists of three letters followed by six numerals.
3. Contact Life Fitness Customer Support Services via the Web at www.lifefitness.com, or call the nearest Life Fitness Customer Support Services group (*refer to page 1 of this manual*). Identify the unit as an Inclusive Fitness model.

3 Specifications

3.1 95C Inclusive Upright Lifecycle Exercise Bike Base

Designed use:	Heavy/Commercial*
Maximum user weight:	181.44 kilograms / 400 pounds
Power requirements:	Self powered. External power is optional.
Pedal size:	166.6 millimeters x 140.9 millimeters / 6.56 inches x 5.5 inches
Pedal speed range:	40 RPM - 120 RPM
Drive type:	Alternator/Belt
Accessory Tray:	Standard
Integrated Reading Rack:	Standard
Color:	Silver with gray and yellow accents

PHYSICAL DIMENSIONS:

Length	110.5 centimeters / 43.5 inches
Width	53.3 centimeters / 21 inches
Height:	151.1 centimeters / 59.5 inches
Weight	79.8 kilograms / 176 pounds
Ground to Step:	16 centimeters / 6.3 inches

SHIPPING DIMENSIONS:

Length:	141 centimeters / 55.5 inches
Width:	69 centimeters / 27 inches
Height:	123 centimeters / 48.25 inches
Weight:	98 kilograms / 216 pounds

Free Manuals Download Website

<http://myh66.com>

<http://usermanuals.us>

<http://www.somanuals.com>

<http://www.4manuals.cc>

<http://www.manual-lib.com>

<http://www.404manual.com>

<http://www.luxmanual.com>

<http://aubethermostatmanual.com>

Golf course search by state

<http://golfingnear.com>

Email search by domain

<http://emailbydomain.com>

Auto manuals search

<http://auto.somanuals.com>

TV manuals search

<http://tv.somanuals.com>