

PARABODY

Serious Steel

415101 400 LEG PRESS ADAPTER KIT

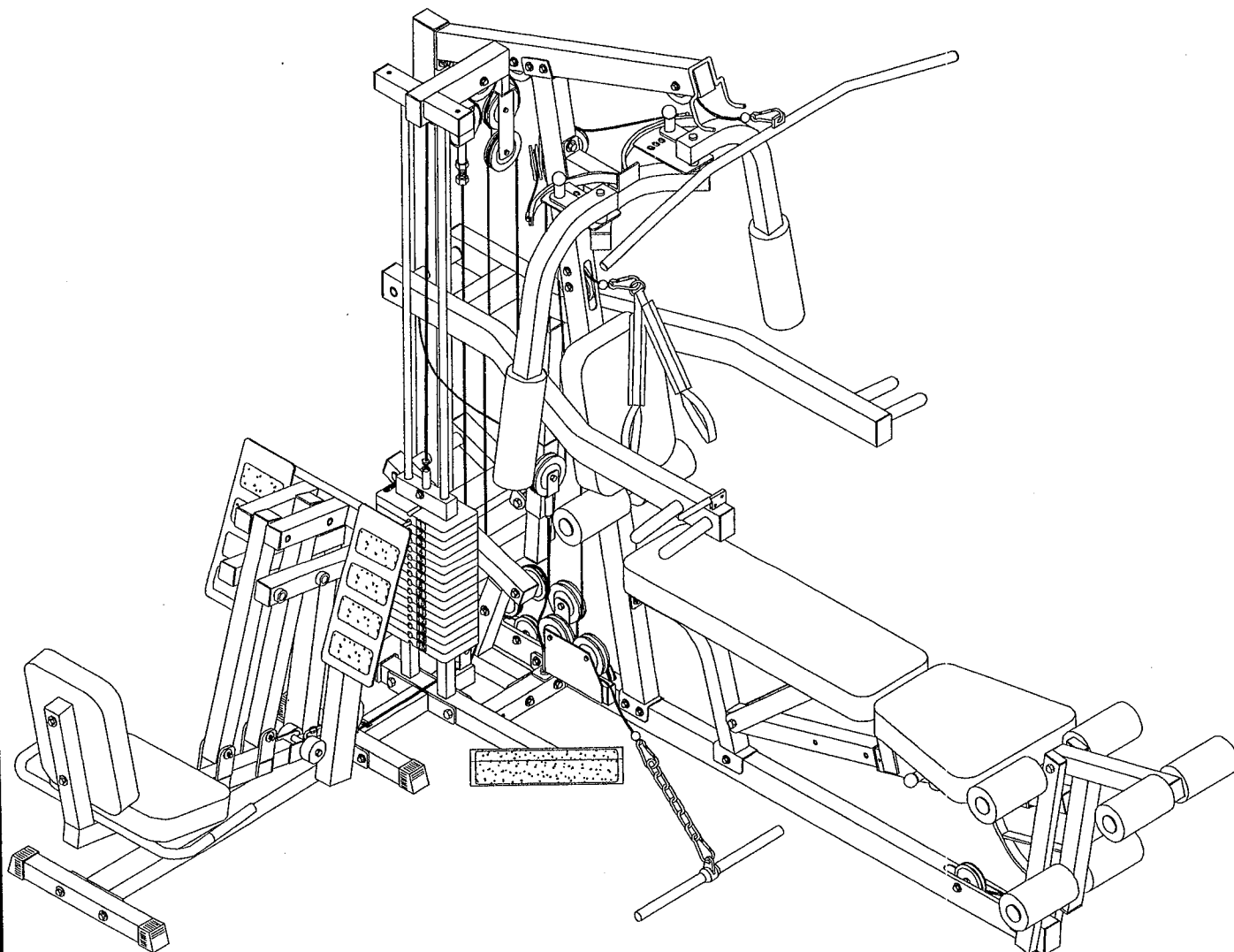

ASSEMBLY INSTRUCTIONS

Part # 6694601

1

Revision: 06/12/97

IMPORTANT NOTES

There is a risk assumed by individuals who use this type of equipment. To minimize risk, please follow these rules:

1. Consult your physician before beginning any exercise program.
2. Inspect equipment daily. Tighten all loose connections and replace worn parts immediately. Failure to do so may result in serious injury.
3. Do not allow minors or children to play on or around this equipment.
4. Exercise with care to avoid injury.
5. If unsure of proper use of equipment, call your local Parabody distributor or call the Parabody customer service department at (800) 328-9714.

Please note:

- * Thank you for purchasing the Parabody 415101 Leg Press Adapter Kit. Please read these instructions thoroughly and keep them for future reference. This product must be assembled on a flat, level surface to assure its proper function.
- * We recommend cleaning your product (pads and frame) on a regular basis, using warm soapy water. Touch-up paint can be purchased from your Parabody customer service representative at (800) 328-9714.

Tools Required for Assembly

- * Rubber mallet or hammer
- * 3/4" wrench
- * 9/16" wrench
- * Ratchet with 3/4" and 9/16" sockets
- * 5/32" Allen wrench
- * Adjustable wrench
- * Tape measure

Bolt Length Ruler

NOTE: BOLT LENGTH IS MEASURED FROM THE UNDERSIDE OF THE HEAD OF THE BOLT.

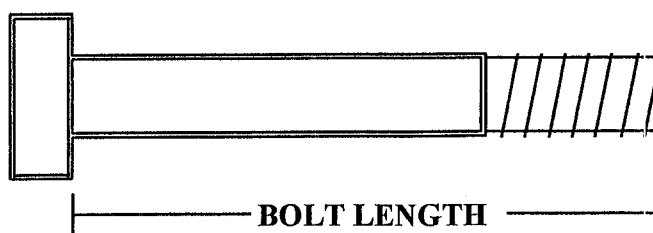

BOLT LENGTH RULER:

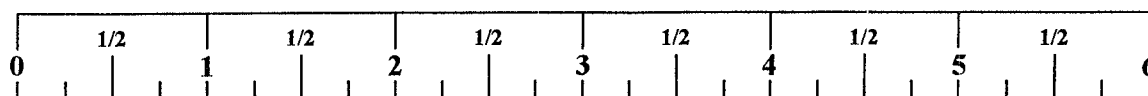

PARTS LIST

KEY	PART #	DESCRIPTION	QTY	KEY	PART #	DESCRIPTION	QTY
1	6686603	FRONT LEG	1	10	3102501	3/8" WASHER	4
2	6693902	PULLEY BRACKET	1	11	3102802	3/8" LOCKNUT	5
3	6694002	CABLE SWIVEL	1	12	3102801	1/2" LOCKNUT	2
4	6694203	BASE CONNECTION	1	13	3102924	3/8 X 1-3/4" BOLT	3
5	3116201	3-1/2" PULLEY	2	14	3102904	3/8 X 3" BOLT	2
6	6405201	2" SQ. END CAP	1	15	3102918	1/2 X 3-1/4" BOLT	2
7	6467001	PARABODY LOGO END CAP	2	16	6694301	112-3/4" CABLE ASSY	1
8	3108102	QUICK DISCONNECT LINK	1	17	6694401	82-1/2" CABLE ASSY	1
9	6140701	GLIDE 1 X 1"	2				

NOTE: The LEG PRESS ATTACHMENT (832101) must be assembled before connecting it to the PARABODY 400 HOME GYM

STEP 1

- Slide two PARABODY LOGO END CAPS (7) over the FRONT LEG (1) as shown in FIGURE 1

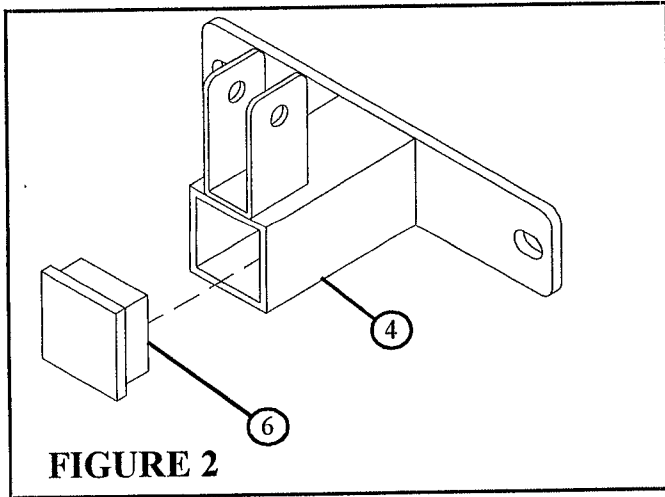
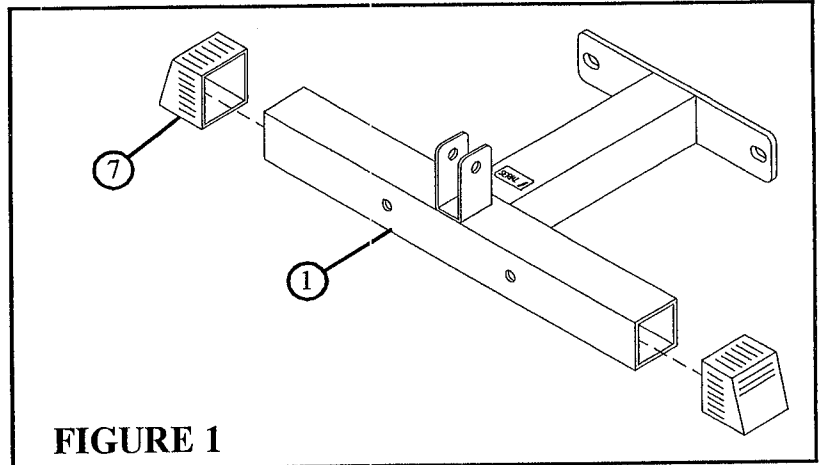

STEP 2

- Slide one 2" SQ. END CAP (6) into the BASE CONNECTION (4) as shown in FIGURE 2.

STEP 3

- Attach two 1 X 1" GLIDES (9) to the top of PULLEY BRACKET (2) as shown in FIGURE 3.

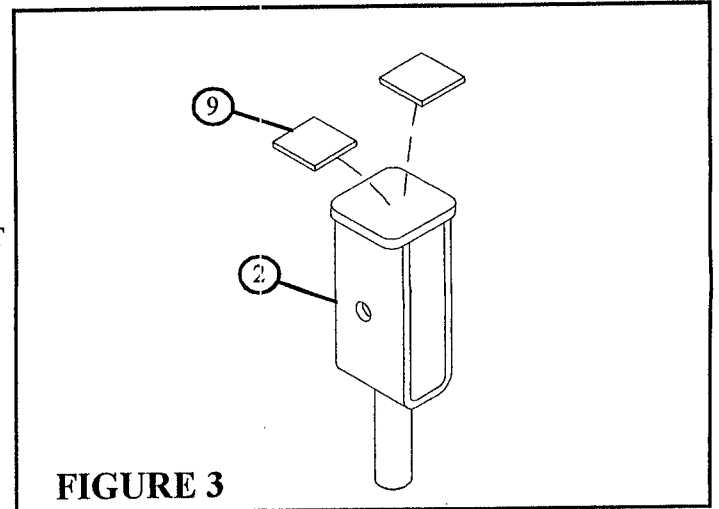

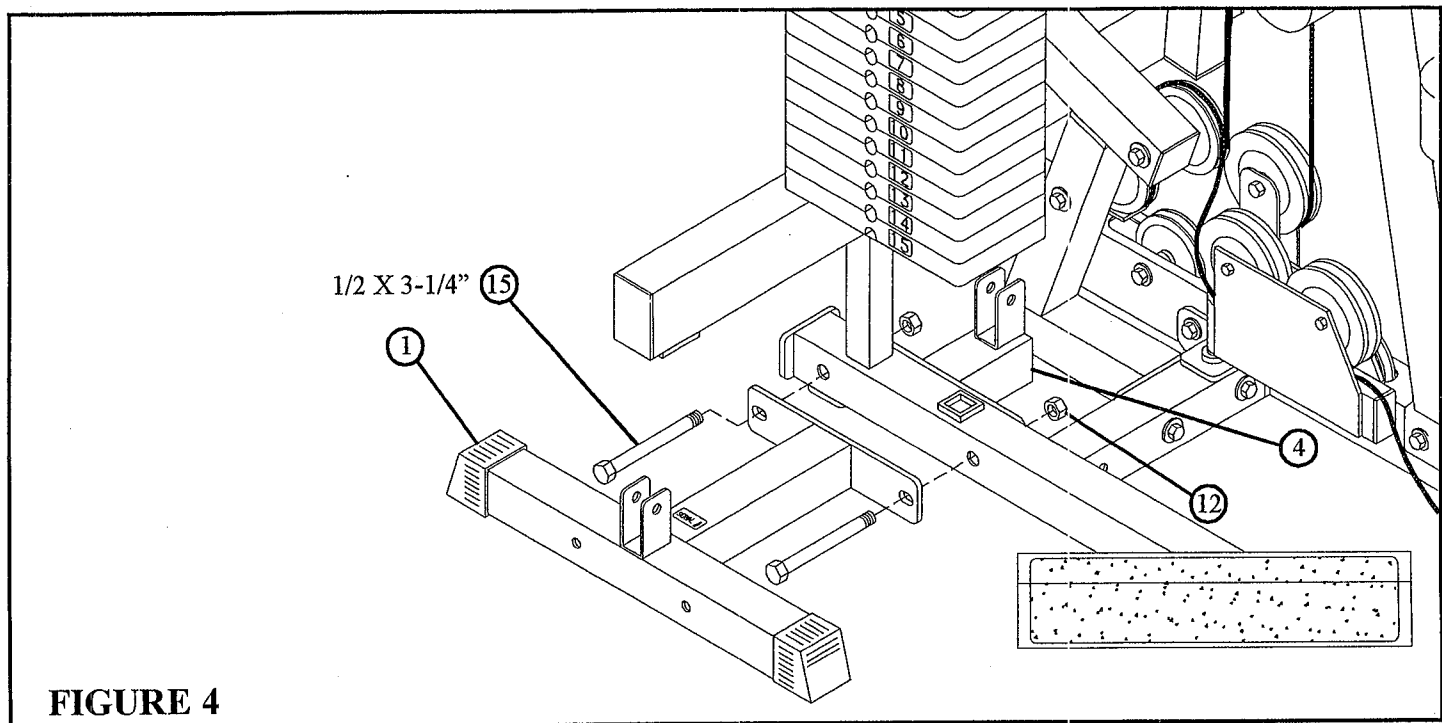

FIGURE 4

STEP 4

- Securely fasten the FRONT LEG (1) and the BASE CONNECTION (4) to the 400 HOME GYM using two 1/2 X 3-1/4" BOLTS (15) and two 1/2" LOCKNUTS (12). See FIGURE 4.

STEP 5

- Remove one existing 3-1/2" PULLEY and two SPACERS from the ADJUSTMENT TUBE on the 832 LEG PRESS OPTION by unfastening the 3/8 X 4-1/2" BOLT holding the pulley on. See FIGURE 5. (Note: Save 3-1/2" PULLEY, it will be used in later steps.)

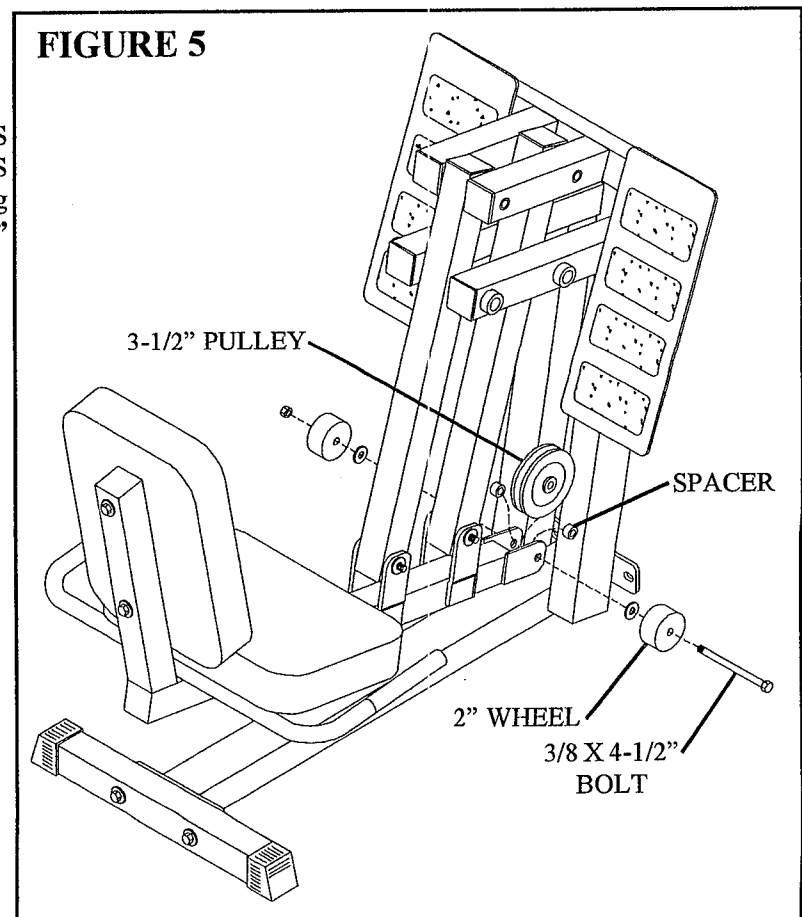
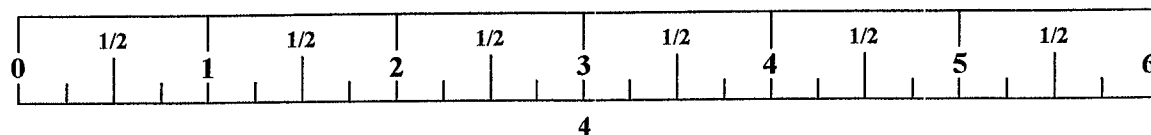

FIGURE 5



STEP 6

- Attach CABLE SWIVEL (3) to the ADJUSTMENT TUBE on the 832 using the existing previously removed 3/8 X 4-1/2" BOLTS, WASHERS, 2" WHEELS AND NUT. (Note: Securely tighten, then back off 1/4 turn to allow the CABLE SWIVEL & WHEELS to rotate freely.) See FIGURE 6.

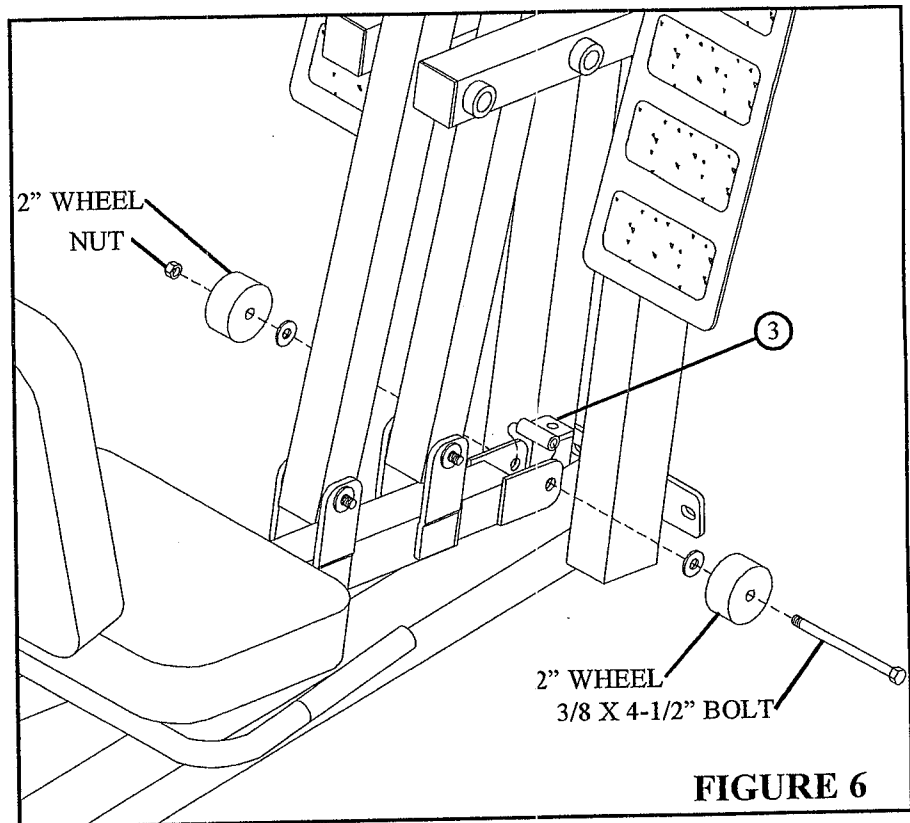

FIGURE 6

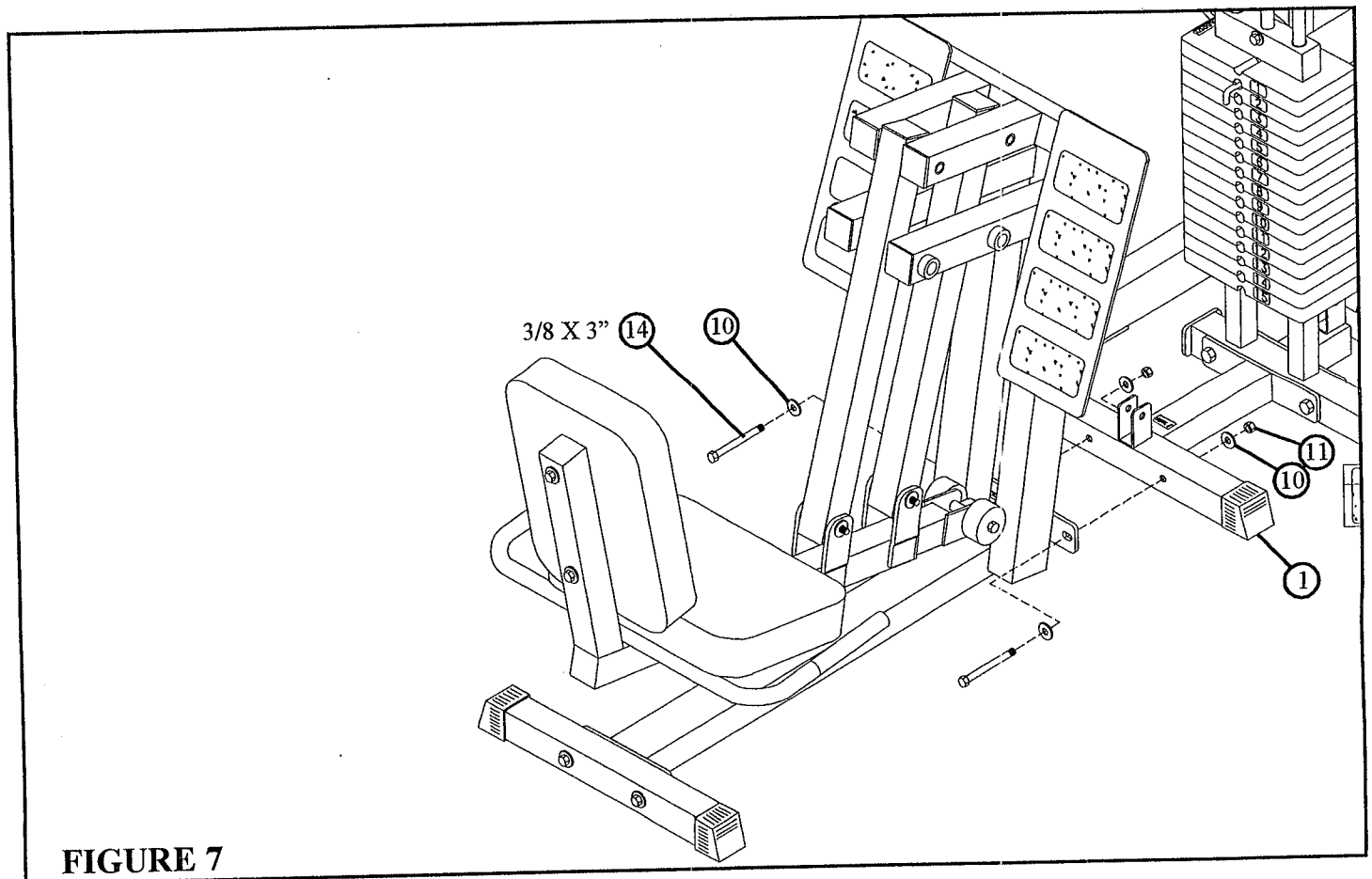
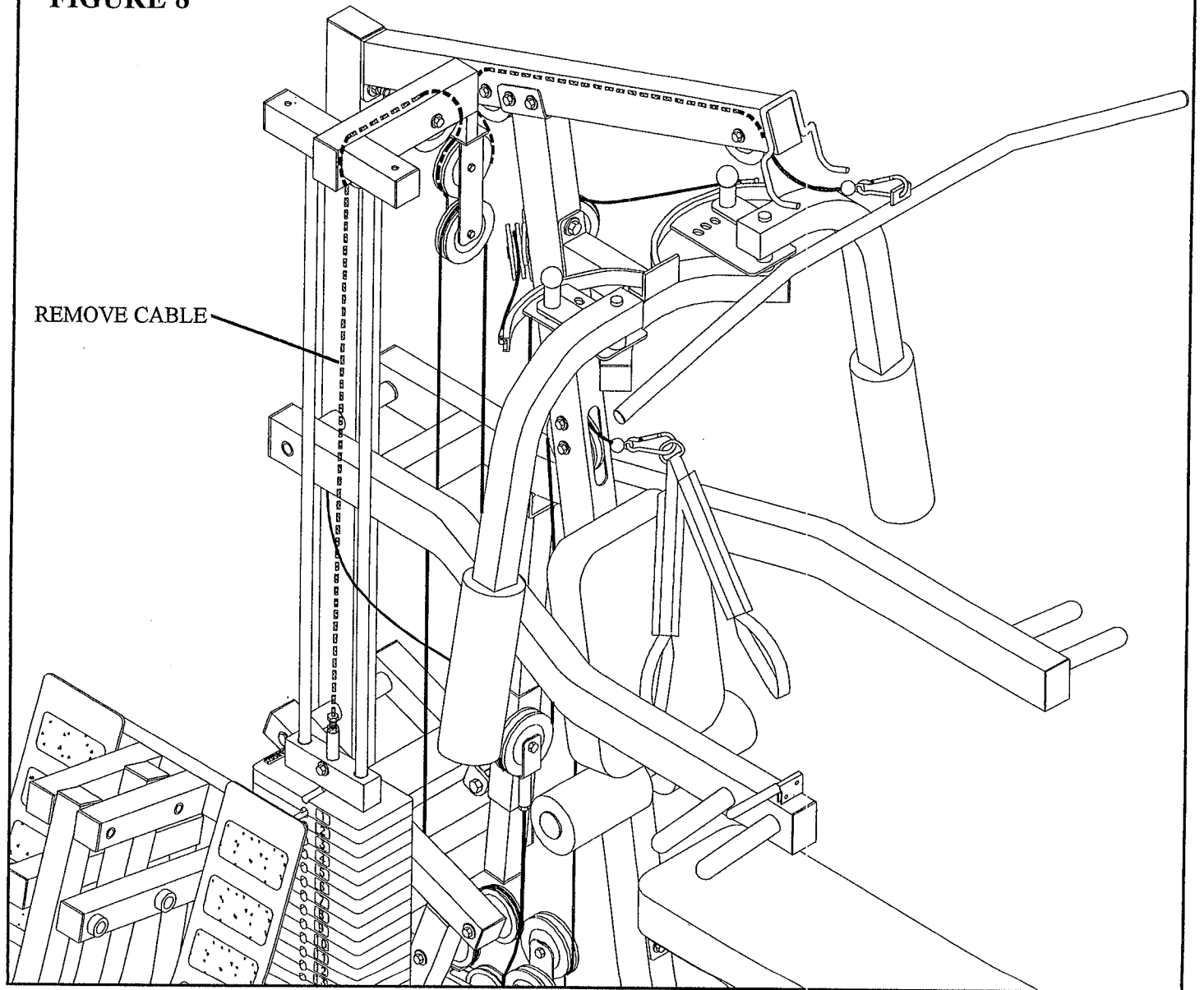

FIGURE 7

STEP 7

- Securely fasten the 832 LEG PRESS to the FRONT LEG (1) using two 3/8 X 3" BOLTS (14), four 3/8" WASHERS (10), and two 3/8" LOCKNUTS (11) as shown in FIGURE 7.

FIGURE 8



STEP 8

Remove the existing LAT CABLE (part #668701) using the following steps:

- Disconnect LAT BAR from TOP BOOM.
- Unscrew the threaded end of CABLE from the HEAD PLATE ASSEMBLY.
- Route the LAT CABLE around the PULLEY BLOCK as shown in FIGURE 8.
- Route the LAT CABLE around the TOP BOOM as shown in FIGURE 8.
- The pulleys in TOP BOOM may need to be temporarily removed to remove CABLE.

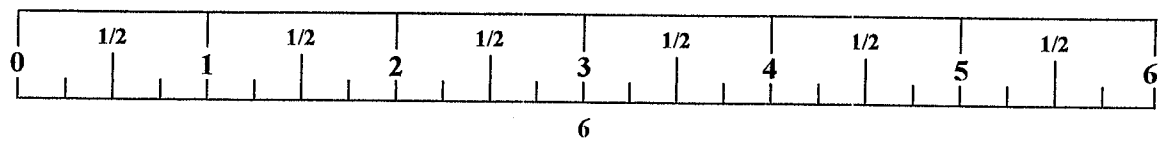
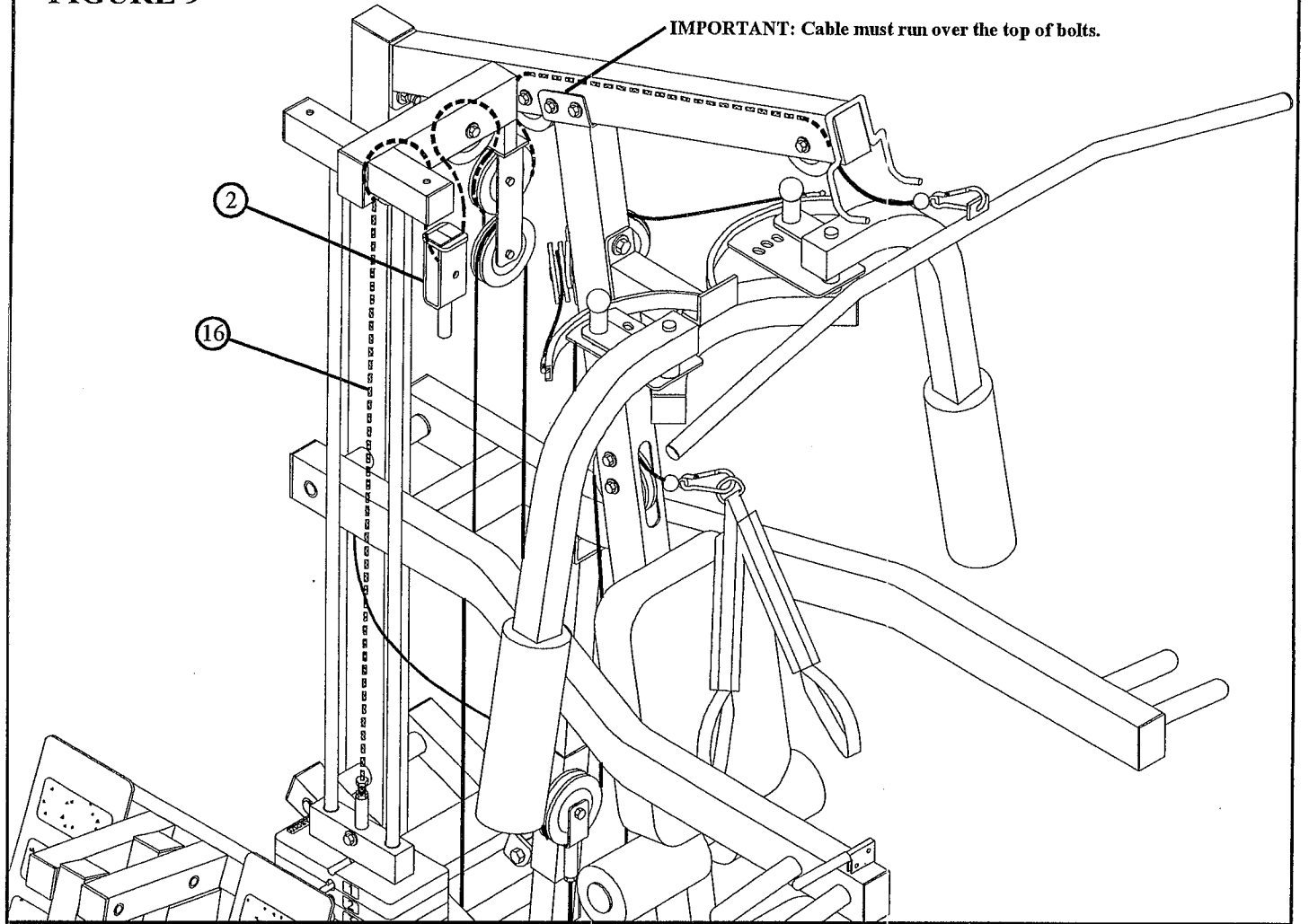

FIGURE 9



STEP 9

Install the NEW 112-3/4" CABLE ASSY (16) using the following steps:

- Route the CABLE (16) through the TOP BOOM as shown in FIGURE 9. The pulleys in TOP BOOM may need to be temporarily removed to perform this step. (Note: Make sure the CABLE is running OVER the BOLTS connecting the FRONT UPRIGHT to the TOP BOOM. These may also have to be removed to perform this step.)
- Route the CABLE (16) around the PULLEY BLOCK as shown in FIGURE 9.
- Route the CABLE (16) back over one pulley in the TOP BOOM, down through the PULLEY BRACKET (2) and over the second pulley in the TOP BOOM.
- Screw the threaded end of CABLE (16) into the HEAD PLATE ASSEMBLY.

STEP 10

- Loop CABLE (16) around one 3-1/2" PULLEY (5) in the PULLEY BRACKET (2) using on 3/8 X 1-3/4" BOLT (13) and one 3/8" LOCKNUT (11) as shown in FIGURE 10.

FIGURE 10

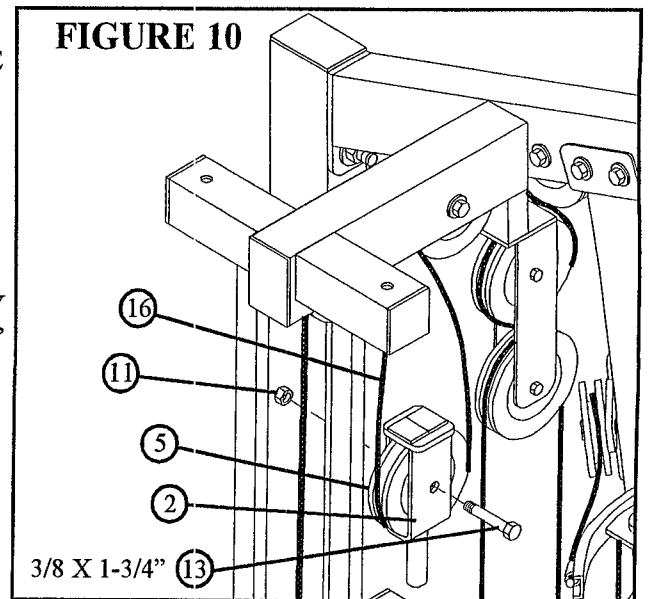
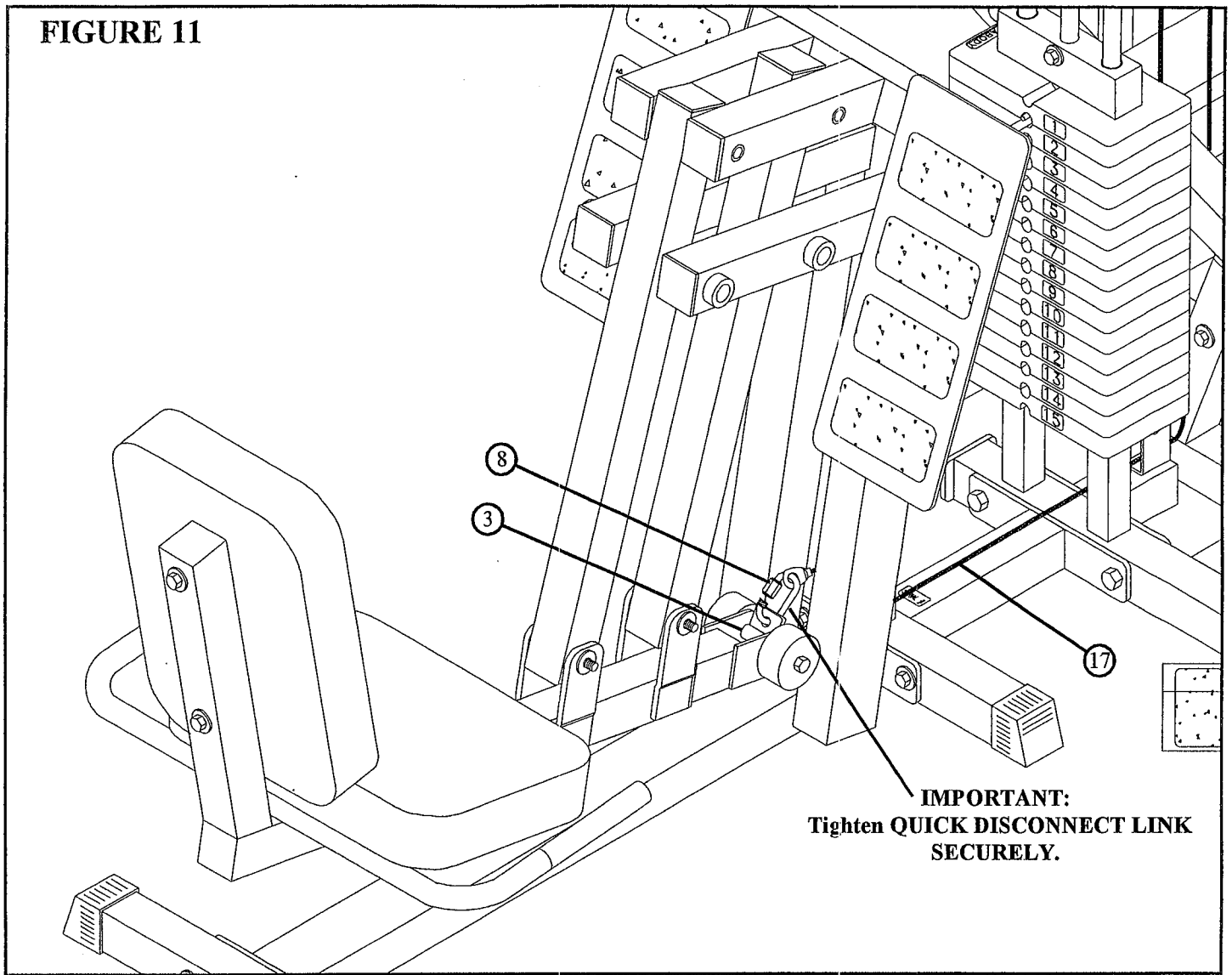
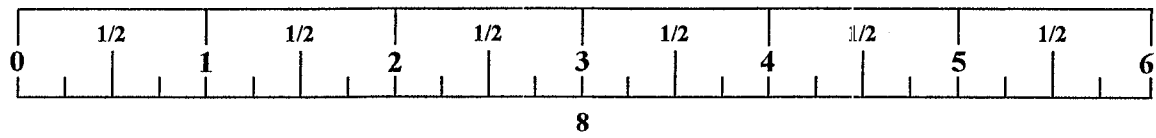

FIGURE 11



STEP 11

- Attach the hook end of 82-1/2" CABLE (17) to the CABLE SWIVEL (3) with one QUICK DISCONNECT LINK (8).
IMPORTANT: Tighten the QUICK DISCONNECT LINK (8) securely.
- Route the 82-1/2" CABLE (17) under the WEIGHT STACK as shown in FIGURE 11.



STEP 12

- Screw the threaded end of 82-1/2" CABLE (17) to the PULLEY BRACKET (2) as shown in FIGURE 12.

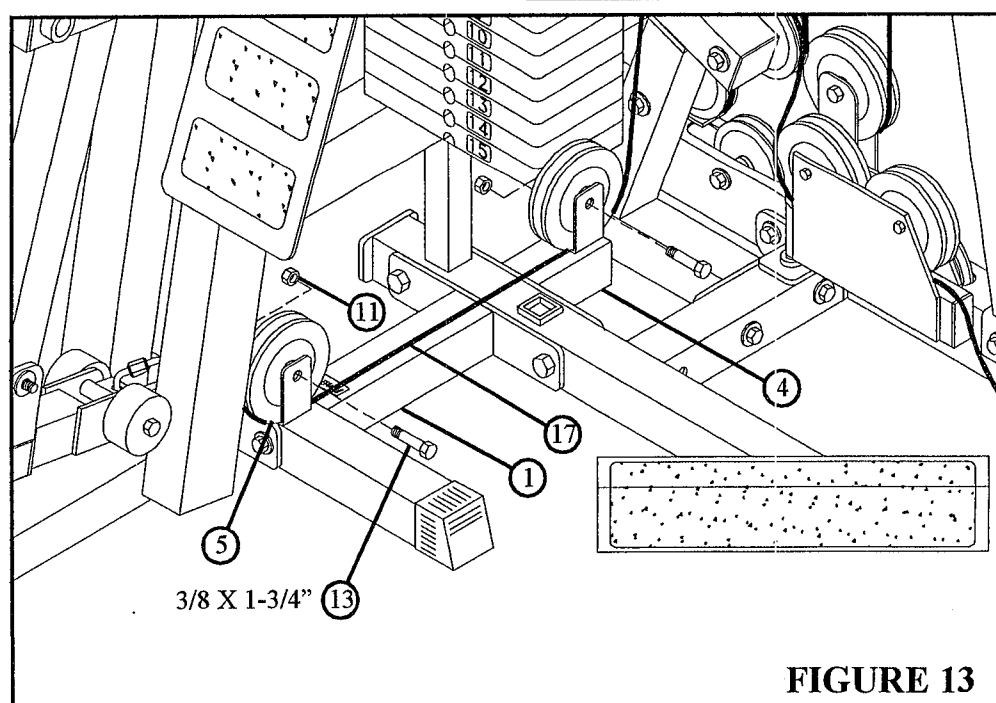
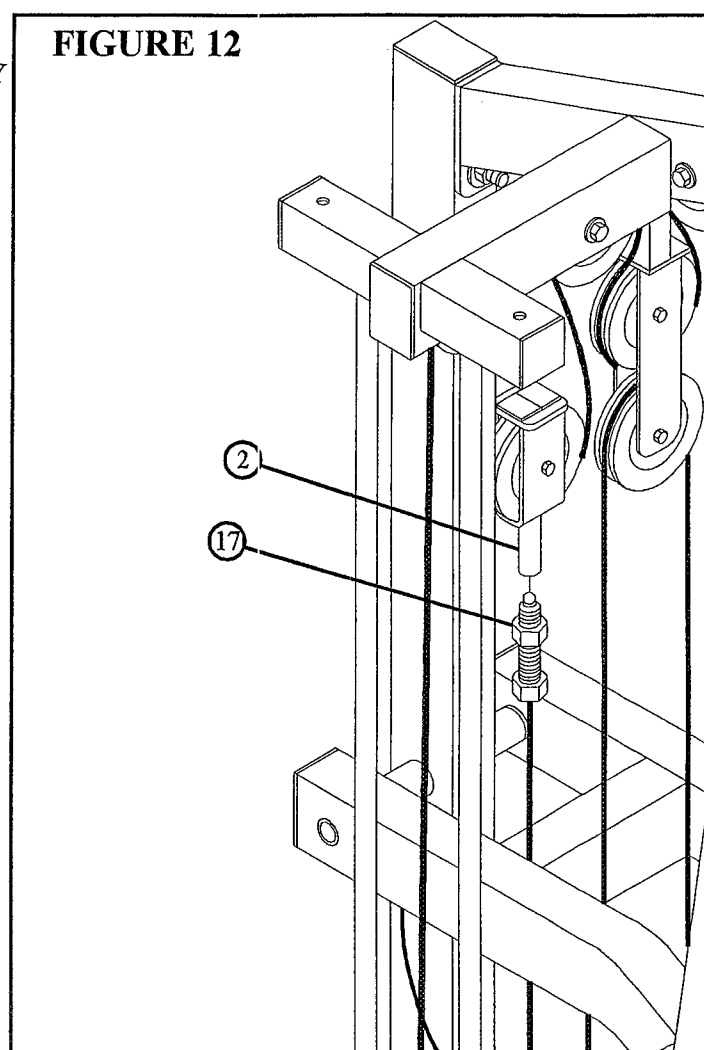

STEP 13

- Attach one 3-1/2" PULLEY (5) to the FRONT LEG (1) and one 3-1/2" PULLEY (5) to the BASE CONNECTION (4) using two 3/8 X 1-3/4" BOLTS (13) and two 3/8" LOCKNUTS. (Note: Make sure CABLE (17) is running under PULLEYS.)

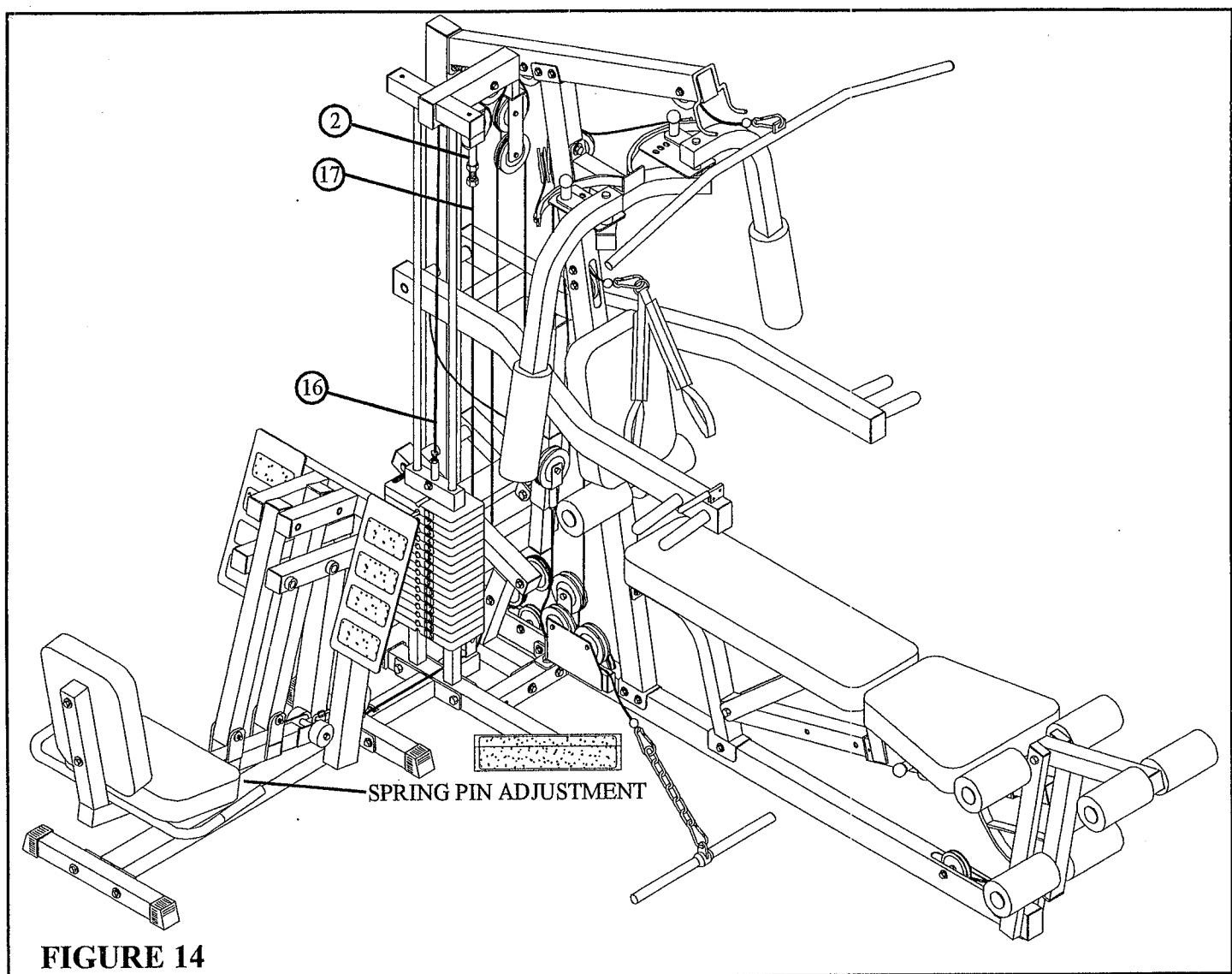
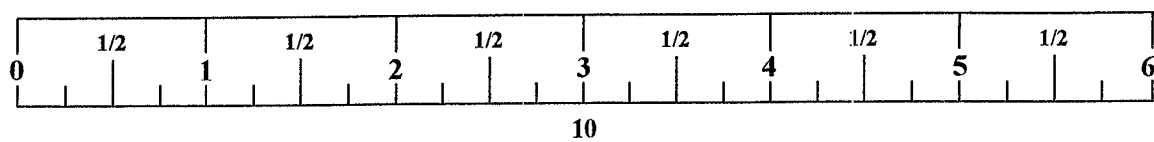

FIGURE 14

STEP 14

- The 832 LEG PRESS is equipped with a spring pin adjustment to accommodate different sized users and allow easy entry and exit from the machine. To use, you must slightly push against the foot plates to take tension off the pin.
- To set the correct amount of tension in the cables, adjust the 832 LEG PRESS into the last adjustment hole (so the LEG PRESS is spread apart) and remove the WEIGHT STACK PIN. Thread the 112-3/4" CABLE (16) into the HEAD PLATE ASSEMBLY until the PULLEY BRACKET (2) is held against the TOP BOOM and the cable is slightly pulling up on the HEAD PLATE. Tighten the jam nut but securely. Next, thread the 82-1/2" CABLE (17) into the PULLEY BRACKET (2) until cable is tight, then tighten the jam nut securely.

THIS CONCLUDES THE ASSEMBLY OF THE 415101 LEG PRESS ADAPTER KIT



Free Manuals Download Website

<http://myh66.com>

<http://usermanuals.us>

<http://www.somanuals.com>

<http://www.4manuals.cc>

<http://www.manual-lib.com>

<http://www.404manual.com>

<http://www.luxmanual.com>

<http://aubethermostatmanual.com>

Golf course search by state

<http://golfingnear.com>

Email search by domain

<http://emailbydomain.com>

Auto manuals search

<http://auto.somanuals.com>

TV manuals search

<http://tv.somanuals.com>