



*Strength Building Gear*

435101  
425 LEG PRESS ADAPTER KIT  
ASSEMBLY INSTRUCTIONS

**SORT AND COUNT ALL PARTS BEFORE BEGINNING ASSEMBLY**

**HARDWARE:**

ITEM	NAME/DESCRIPTION	QTY
1.	1/2 X 3 IN. BOLT .....	4
2.	3/8 X 4-1/2 IN. THREADED SHAFT .....	1
3.	3/8 IN. WASHER .....	2
4.	1/2 IN. WASHER .....	2
5.	1/2 IN. LOCK NUT .....	4
6.	3/8 IN. LOCK NUT .....	3
7.	3/8 IN. NUT .....	1
8.	KEYHOLE CLEVIS .....	1
9.	SWIVEL .....	1
10.	2-3/8 IN. CABLE RETAINING CLIP .....	2
11.	QUICK DISCONNECT LINK .....	1
12.	1/4 IN. CAP NUT .....	1
13.	2 SQ. END CAP .....	2
14.	SHOCK CORD .....	1
15.	2 IN. PULLEY .....	1
16.	3-1/2 X 1 IN. PULLEY .....	2
17.	3/8 X 2 IN. BOLT .....	2

**NOTE: BOLT LENGTH IS MEASURED FROM THE UNDERSIDE OF THE HEAD OF THE BOLT.**

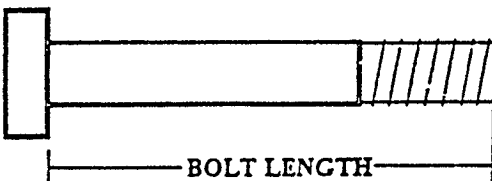

**BOLT LENGTH RULER:**

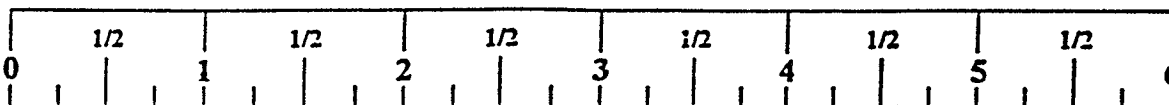

## 425 LEG PRESS ADAPTER KIT ASSEMBLY INSTRUCTIONS

**NOTE: IF THE REAR SHROUD IS ASSEMBLED TO THE PARABODY 425, IT WILL NEED TO BE REMOVED TO ASSEMBLE THE LEG PRESS AND THE ADAPTER KIT. PLEASE REMOVE THE SHROUD AT THIS TIME BY REMOVING THE FOUR (4) 3/8 X 1 IN. BOLTS AND FOUR 3/8 IN. WASHERS.**

**NOTE: THE LEG PRESS ATTACHMENT (832101) MUST BE ASSEMBLED BEFORE ASSEMBLING IT TO THE PARABODY 425. PLEASE ASSEMBLE THE LEG PRESS ATTACHMENT AT THIS TIME USING THE 832 PRODUCT ASSEMBLY INSTRUCTIONS.**

1. Attach two (2) 2 SQ. IN. COVER CAPS onto the FRONT LEG WELDMENT as shown on drawing.
2. Remove two (2) 1/2 IN. LOCK NUTS and two (2) 1/2 IN. WASHERS FROM the PRESS BASE \ BASE connection of the 425.
3. SECURELY assemble the BASE CONNECTION WELDMENT to the PRESS BASE and BASE connection of the 425 using the two (2) 1/2 IN. LOCK NUTS REMOVED IN STEP 2.
4. SECURELY attach the assembled 832 LEG PRESS ATTACHMENT to the FRONT LEG WELDMENT using two (2) 1/2 X 3 IN. BOLTS, two (2) 1/2 IN. WASHERS (FROM STEP 2) and two (2) 1/2 IN. LOCK NUTS.
5. SECURELY attach the 832 to the 425 by connecting the FRONT LEG WELDMENT to the BASE CONNECTION WELDMENT, using two (2) 1/2 X 3 IN. BOLTS, two (2) 1/2 IN. WASHERS and two (2) 1/2 IN. LOCK NUTS.
6. Remove one (1) 1/4 IN. CAP NUT from the rear L-hook of the TOP BOOM. (LEAVE 2 IN. PULLEY ON L-HOOK)
7. Assemble one (1) 2 IN. PULLEY to the rear L-hook and secure place with one (1) 1/4 IN. CAP NUT.
8. CAREFULLY remove one (1) 3/8 IN. LOCK NUT and one (1) SWIVEL WITH MULTI-PRESS SHOCK CORD from the rear flat of the BASE.
9. Remove one 3/8 IN. NUT, one (1) 2-3/8 IN. CABLE RETAINING CLIP, one (1) 3-1/2 X 1 IN. PULLEY, one (1) 3/8 X 2-1/2 IN BOLT, and one (1) 3/8 IN. WASHER from the rear flat of the BASE.
10. Reassemble one (1) 3-1/2 x 1 IN. PULLEY, one (1) 2-3/8 IN. CABLE RETAINING CLIP, one 3/8 IN. WASHER, and one (1) 3/8 IN. NUT, from Step 9 to the rear flat of the BASE using one (1) 3/8 x 4-1/2 IN. THREADED STUD, and one (1) 3/8 IN. NUT.
11. Reassemble one (1) SWIVEL WITH MULTI-PRESS SHOCK CORD to the 3/8 X 4-1/2 IN. THREADED STUD, using one (1) 3/8 IN. LOCK NUT. (PARTS ARE FROM STEP 8)
12. Assemble one (1) 3-1/2 x 1 IN. PULLEY to the flat facing the leg press on the BASE, and one (1) 3-1/2 IN. PULLEY to the flat on the FRONT LEG WELDMENT using two (2) 3/8 x 2 IN. BOLTS, two (2) 3/8 IN. WASHERS, two (2) 2-3/8 IN. CABLE RETAINING CLIPS, and two (2) 3/8 IN. LOCK NUTS.
13. To assemble the LEG PRESS CABLE, follow the cable routing diagram and use the following steps:
  - Adjust the LEG PRESS so the seat is in its tightest pre-stretch position.
  - SECURELY attach the loop end of the LEG PRESS CABLE to the FRONT LEG WELDMENT using one (1) QUICK DISCONNECT LINK.
  - Run the cable through the hole in the D-RING as shown in (DETAIL A) and attach one (1) KEYHOLE CLEVIS to the end of the LEG PRESS CABLE.

## 425 LEG PRESS ADAPTER KIT ASSEMBLY INSTRUCTIONS

**NOTE: IF THE CABLE APPEARS TO BE TOO SHORT, MAKE SURE LEG PRESS IS ADJUSTED SO THE SEAT AND FOOT PLATES ARE IN THEIR CLOSEST POSITION. THE D-RING CABLE ON THE 425 MAY ALSO NEED TO BE ADJUSTED.**

**NOTE: IF THE 445101, 425 2ND STACK OPTION IS INSTALLED, AND THE REAR SHROUD HAS AN OVAL SLOT, THE LEG PRESS CABLE WILL HAVE TO BE LOOPED THROUGH THE SLOT PRIOR TO FINISHING STEP 13.**

14. Attach one (1) SHOCK CORD to the KEYHOLE CLEVIS on the end of the LEG PRESS CABLE, and route the SHOCK CORD up and around the second 2 IN. PULLEY above the D-RING and down to the BASE.
15. Attach one (1) SWIVEL to the end of the SHOCK CORD. Slip the end of the swivel over the 3/8 X 4-1/2 IN THREADED SHAFT, and SECURE in place with one (1) 3/8 IN. LOCK NUT.
16. SECURELY attach the REAR SHROUD using four (4) 3/8 X 1 IN. BOLTS and four (4) 3/8 IN. WASHERS.
17. The 832 LEG PRESS OPTION is equipped with a SPRING PIN ADJUSTMENT to accommodate different sized users and to allow easy entry and exit from the machine. To use, you must slightly push against the foot plates to take tension off the pin.

REVISIONS				
REV	DESCRIPTION	DATE	BY	CHKD
B				

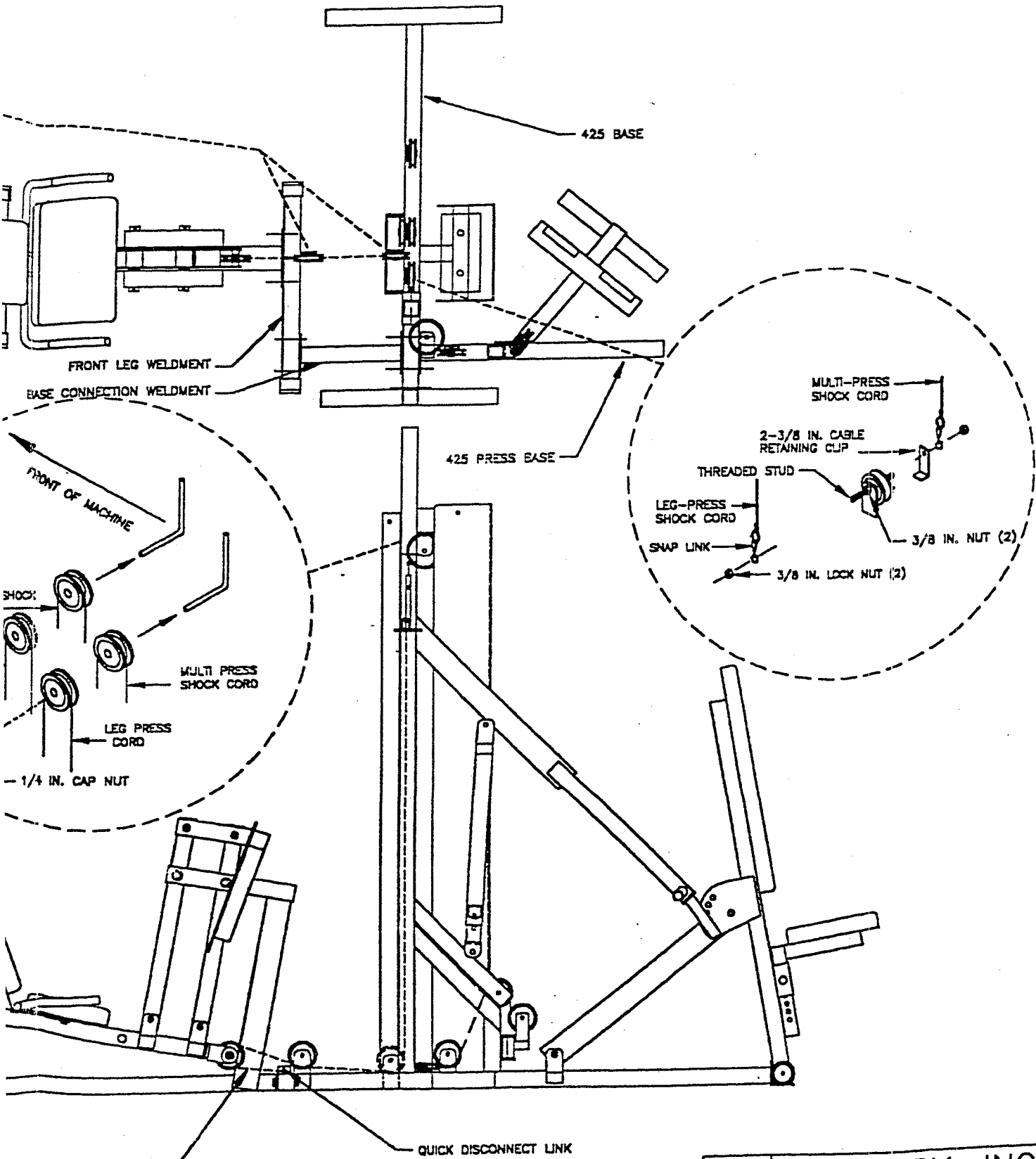

CABLE ROUTING DIAGRAM

TELEPHONE		PARABODY, INC.	
ADDRESS		RAMSEY, MINNESOTA	
TITLE	ASSY INST, 431101	REV	65798
QUANTITY	1/8	DATE	
DESCRIPTION	1 OF 1	BY	B
DATE	TXR	11/28	12/28

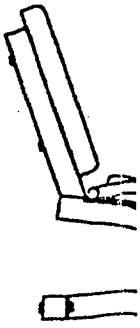
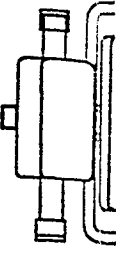
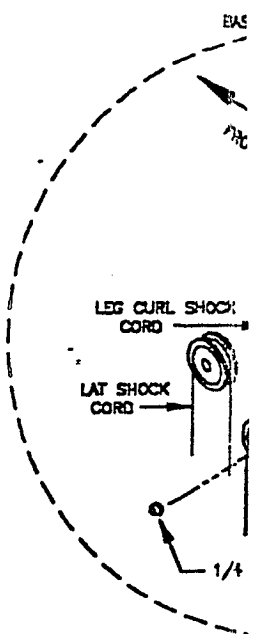
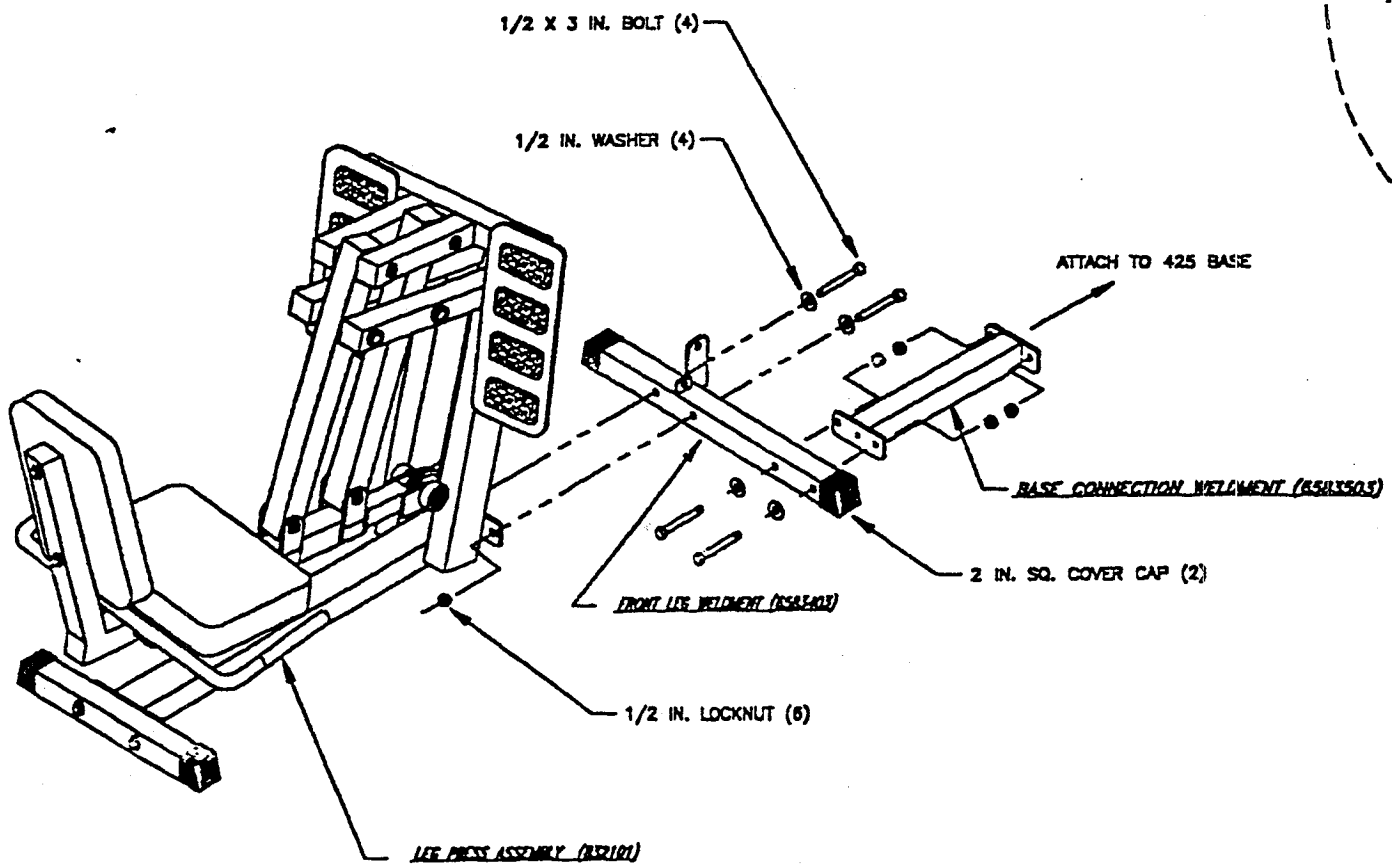
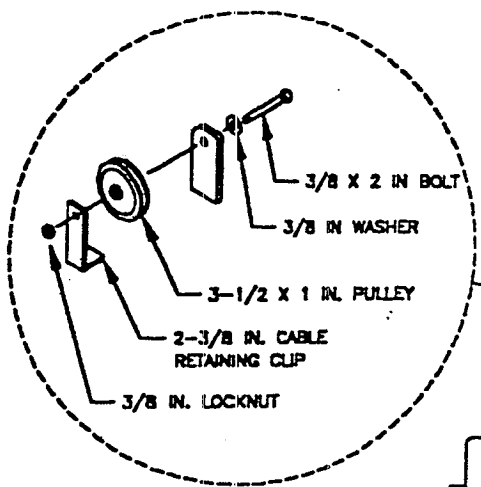
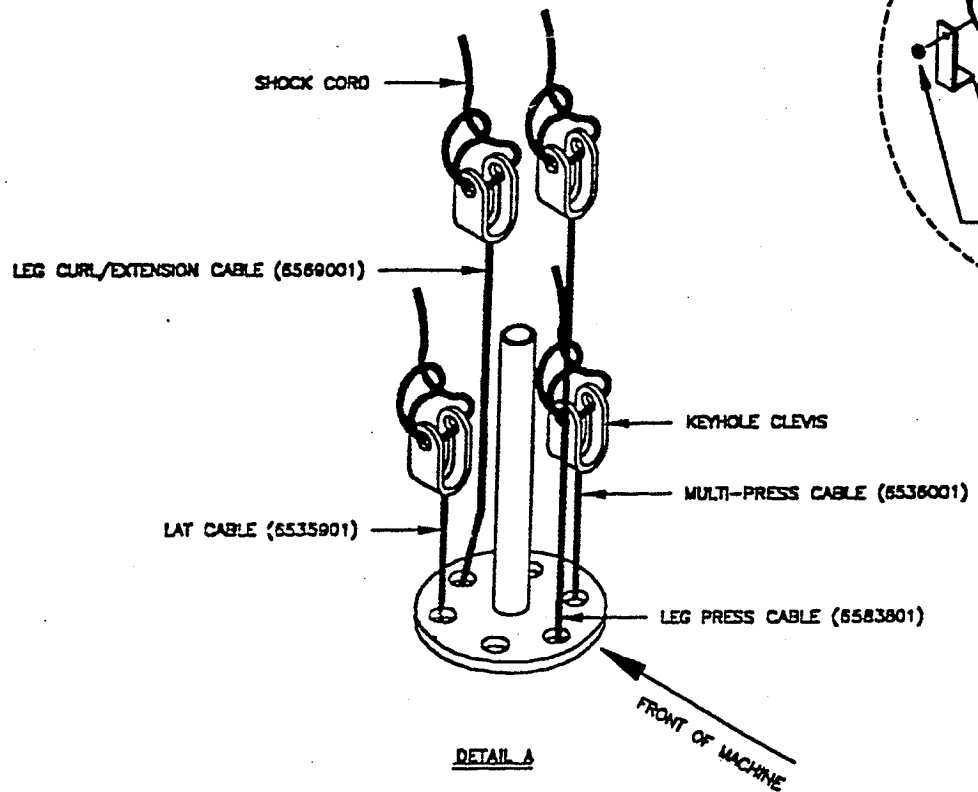



435101  
**425 LEG PRESS ADAPTER KIT  
 ASSEMBLY INSTRUCTIONS**

**SORT AND COUNT ALL PARTS BEFORE BEGINNING ASSEMBLY**

**HARDWARE:**

ITEM	NAME/DESCRIPTION	QTY
1.	1/2 X 3 IN. BOLT .....	4
2.	3/8 X 4-1/2 IN. THREADED SHAFT .....	1
3.	3/8 IN. WASHER .....	2
4.	1/2 IN. WASHER .....	2
5.	1/2 IN. LOCK NUT .....	4
6.	1/2 IN. LOCK NUT .....	3
7.	3/8 IN. LOCK NUT .....	1
8.	3/8 IN. NUT .....	1
9.	KEYHOLE CLEVIS .....	1
10.	SWIVEL .....	1
11.	2-3/8 IN. CABLE RETAINING CLIP .....	2
12.	QUICK DISCONNECT LINK .....	1
13.	1/4 IN. CAP NUT .....	1
14.	2 SQ. END CAP .....	2
15.	SHOCK CORD .....	1
16.	2 IN. PULLEY .....	1
17.	3-1/2 X 1 IN. PULLEY .....	2
	3/8 X 2 IN. BOLT .....	2

**NOTE: BOLT LENGTH IS MEASURED FROM THE UNDERSIDE OF THE HEAD OF THE BOLT.**

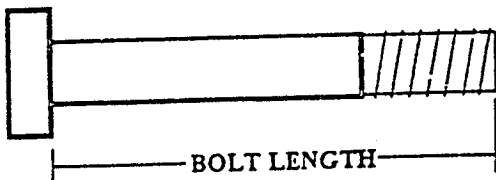

**BOLT LENGTH RULER:**

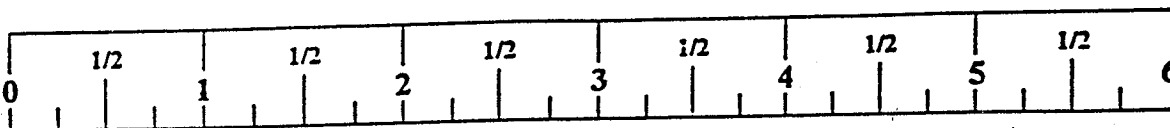

## 425 LEG PRESS ADAPTER KIT ASSEMBLY INSTRUCTIONS

**NOTE: IF THE REAR SHROUD IS ASSEMBLED TO THE PARABODY 425, IT WILL NEED TO BE REMOVED TO ASSEMBLE THE LEG PRESS AND THE ADAPTER KIT. PLEASE REMOVE THE SHROUD AT THIS TIME BY REMOVING THE FOUR (4) 3/8 X 1 IN. BOLTS AND FOUR 3/8 IN. WASHERS.**

**NOTE: THE LEG PRESS ATTACHMENT (832101) MUST BE ASSEMBLED BEFORE ASSEMBLING IT TO THE PARABODY 425. PLEASE ASSEMBLE THE LEG PRESS ATTACHMENT AT THIS TIME USING THE 832 PRODUCT ASSEMBLY INSTRUCTIONS.**

1. Attach two (2) 2 SQ. IN. COVER CAPS onto the **FRONT LEG WELDMENT** as shown on drawing.
2. Remove two (2) 1/2 IN. LOCK NUTS and two (2) 1/2 IN. WASHERS FROM the **PRESS BASE \ BASE** connection of the 425.
3. **SECURELY** assemble the **BASE CONNECTION WELDMENT** to the **PRESS BASE** and **BASE** connection of the 425 using the two (2) 1/2 IN. LOCK NUTS REMOVED IN STEP 2.
4. **SECURELY** attach the assembled **832 LEG PRESS ATTACHMENT** to the **FRONT LEG WELDMENT** using two (2) 1/2 X 3 IN. BOLTS, two (2) 1/2 IN. WASHERS (*FROM STEP 2*) and two (2) 1/2 IN. LOCK NUTS.
5. **SECURELY** attach the 832 to the 425 by connecting the **FRONT LEG WELDMENT** to the **BASE CONNECTION WELDMENT**, using two (2) 1/2 X 3 IN. BOLTS, two (2) 1/2 IN. WASHERS and two (2) 1/2 IN. LOCK NUTS.
6. Remove one (1) 1/4 IN. CAP NUT from the rear L-hook of the **TOP BOOM**. (**LEAVE 2 IN. PULLEY ON L-HOOK**)
7. Assemble one (1) 2 IN. PULLEY to the rear L-hook and secure place with one (1) 1/4 IN. CAP NUT.
8. **CAREFULLY** remove one (1) 3/8 IN. LOCK NUT and one (1) SWIVEL WITH MULTI-PRESS SHOCK CORD from the rear flat of the **BASE**.
9. Remove one 3/8 IN. NUT, one (1) 2-3/8 IN. CABLE RETAINING CLIP, one (1) 3-1/2 X 1 IN. PULLEY, one (1) 3/8 X 2-1/2 IN BOLT, and one (1) 3/8 IN. WASHER from the rear flat of the **BASE**.
10. Reassemble one (1) 3-1/2 x 1 IN. PULLEY, one (1) 2-3/8 IN. CABLE RETAINING CLIP, one 3/8 IN. WASHER, and one (1) 3/8 IN. NUT, *from Step 9* to the rear flat of the **BASE** using one (1) 3/8 x 4-1/2 IN. THREADED STUD, and one (1) 3/8 IN. NUT.
11. Reassemble one (1) SWIVEL WITH MULTI-PRESS SHOCK CORD to the 3/8 X 4-1/2 IN. THREADED STUD, using one (1) 3/8 IN. LOCK NUT. (*PARTS ARE FROM STEP 8*)
12. Assemble one (1) 3-1/2 x 1 IN. PULLEY to the flat facing the leg press on the **BASE**, and one (1) 3-1/2 IN. PULLEY to the flat on the **FRONT LEG WELDMENT** using two (2) 3/8 x 2 IN. BOLTS, two (2) 3/8 IN. WASHERS, two (2) 2-3/8 IN. CABLE RETAINING CLIPS, and two (2) 3/8 IN. LOCK NUTS.
13. To assemble the **LEG PRESS CABLE**, follow the cable routing diagram and use the following steps:
  - Adjust the **LEG PRESS** so the seat is in its tightest pre-stretch position.
  - **SECURELY** attach the loop end of the **LEG PRESS CABLE** to the **FRONT LEG WELDMENT** using one (1) **QUICK DISCONNECT LINK**.
  - Run the cable through the hole in the **D-RING** as shown in (**DETAIL A**) and attach one (1) **KEYHOLE CLEVIS** to the end of the **LEG PRESS CABLE**.

## 425 LEG PRESS ADAPTER KIT ASSEMBLY INSTRUCTIONS

**NOTE: IF THE CABLE APPEARS TO BE TOO SHORT, MAKE SURE LEG PRESS IS ADJUSTED SO THE SEAT AND FOOT PLATES ARE IN THEIR CLOSEST POSITION. THE D-RING CABLE ON THE 425 MAY ALSO NEED TO BE ADJUSTED.**

**NOTE: IF THE 445101, 425 2ND STACK OPTION IS INSTALLED, AND THE REAR SHROUD HAS AN OVAL SLOT, THE LEG PRESS CABLE WILL HAVE TO BE LOOPED THROUGH THE SLOT PRIOR TO FINISHING STEP 13.**

14. Attach one (1) SHOCK CORD to the KEYHOLE CLEVIS on the end of the LEG PRESS CABLE, and route the SHOCK CORD up and around the second 2 IN. PULLEY above the D-RING and down to the BASE.
15. Attach one (1) SWIVEL to the end of the SHOCK CORD. Slip the end of the swivel over the 3/8 X 4-1/2 IN THREADED SHAFT, and SECURE in place with one (1) 3/8 IN. LOCK NUT.
16. SECURELY attach the REAR SHROUD using four (4) 3/8 X 1 IN. BOLTS and four (4) 3/8 IN. WASHERS.
17. The 832 LEG PRESS OPTION is equipped with a SPRING PIN ADJUSTMENT to accommodate different sized users and to allow easy entry and exit from the machine. To use, you must slightly push against the foot plates to take tension off the pin.



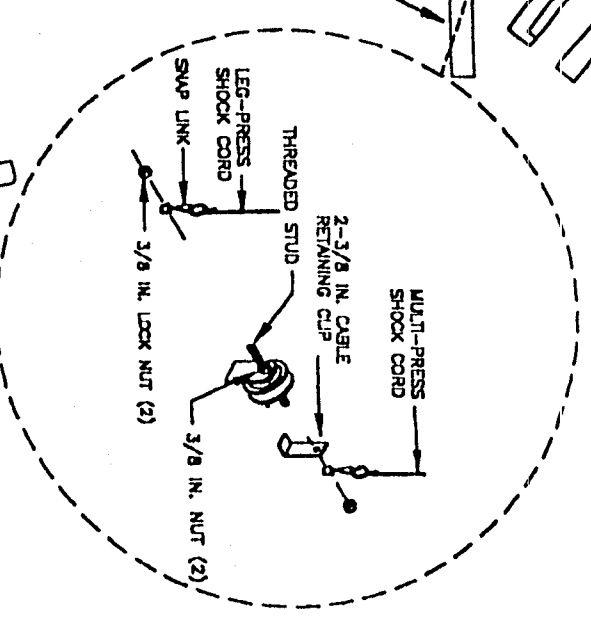
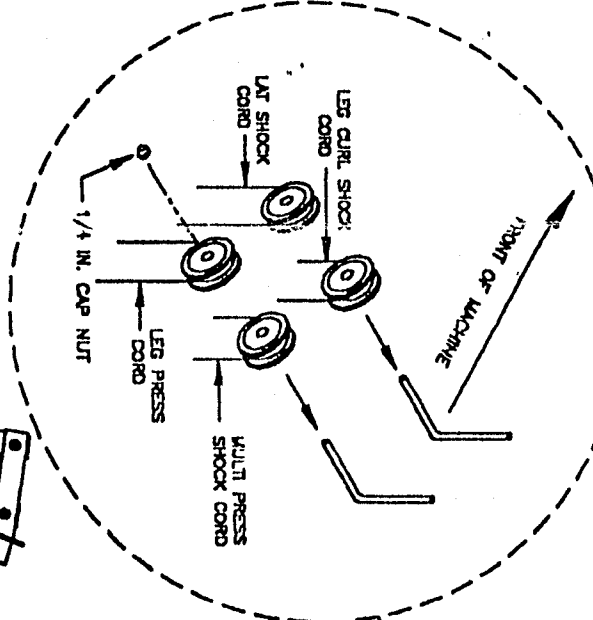
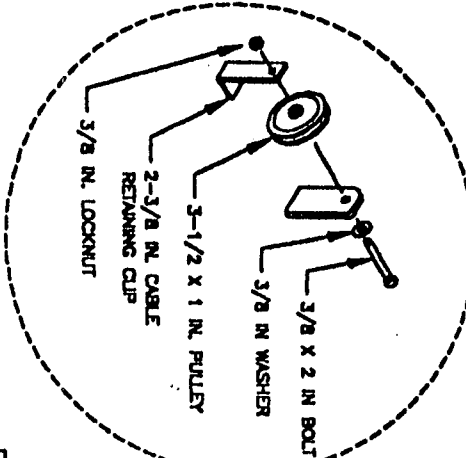
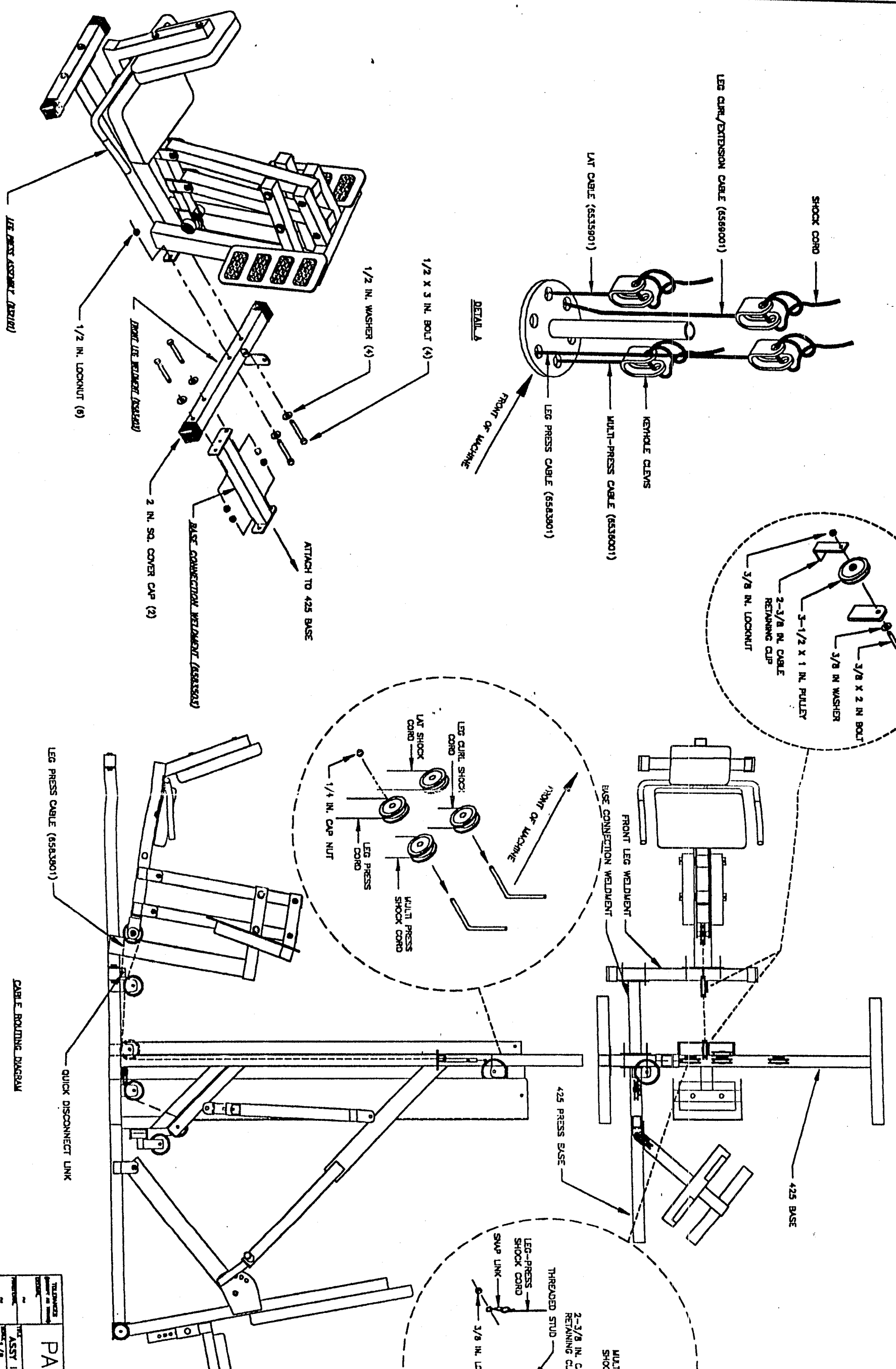

TEL: 612-551-1111		FAX: 612-551-1112	
PARABODY, INC.			
RAMSEY, MINNESOTA			
THE ASSY INST. 433101		65798	
REV. 1 OF 1	8	DATE	PLM
REV. 1/2/98	8	DATE	PLM

REVISIONS			
REV.	DATE	BY	APP.
1			

## Free Manuals Download Website

<http://myh66.com>

<http://usermanuals.us>

<http://www.somanuals.com>

<http://www.4manuals.cc>

<http://www.manual-lib.com>

<http://www.404manual.com>

<http://www.luxmanual.com>

<http://aubethermostatmanual.com>

Golf course search by state

<http://golfingnear.com>

Email search by domain

<http://emailbydomain.com>

Auto manuals search

<http://auto.somanuals.com>

TV manuals search

<http://tv.somanuals.com>