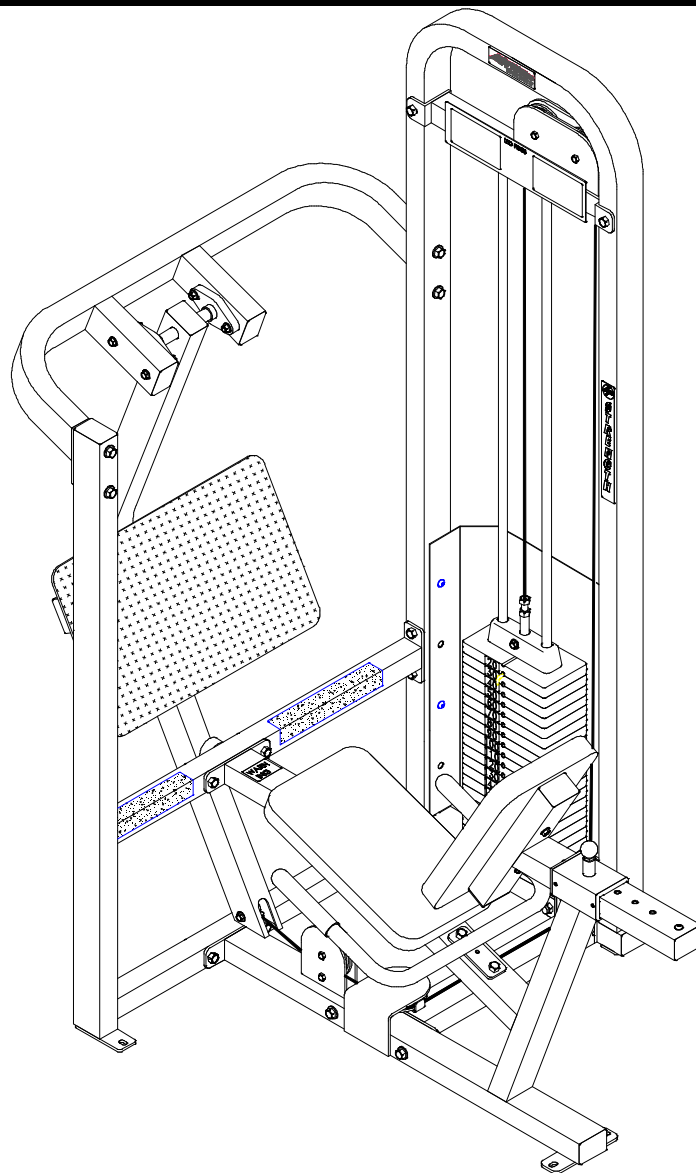


# **Life Fitness**

## **STRENGTH**

### **8245102 LEG PRESS/CALF**

---



---

## **ASSEMBLY INSTRUCTIONS**



## IMPORTANT NOTES

### Please note:

- \* Thank you for purchasing the LIFE FITNESS 8245 LEG PRESS/CALF. Please read these instructions thoroughly and keep them for future reference. This product must be assembled on a flat, level surface to assure its proper function.
- \* We recommend cleaning your product (pads and frame) on a regular basis, using warm soapy water. Touch-up paint can be purchased from your LIFE FITNESS customer service representative at (800) 328-9714.

There is a risk assumed by individuals who use this type of equipment. To minimize risk, please follow these rules:

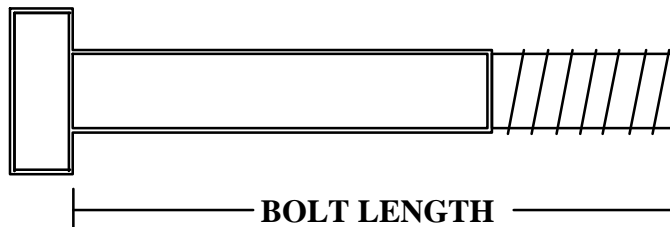
1. Inspect equipment daily. Tighten all loose connections and replace worn parts immediately. Failure to do so may result in serious injury.
2. Do not allow minors or children to play on or around this equipment.
3. Exercise with care to avoid injury.
4. If unsure of proper use of equipment, call your local LIFE FITNESS STRENGTH distributor or call the LIFE FITNESS STRENGTH customer service department at (800) 328-9714.
5. Consult your physician before beginning any exercise program.

## Tools Required for Assembly

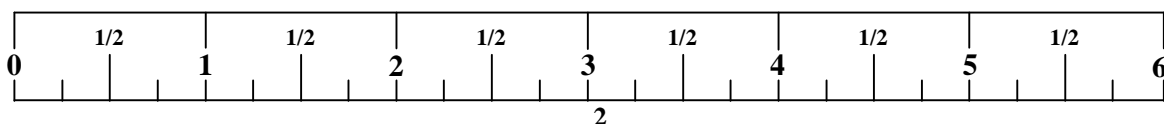
- \* 3/4" wrench, 9/16" wrench
- \* Ratchet with 3/4" and 9/16" sockets
- \* 5/32", 7/32" Allen wrenches
- \* Adjustable wrench
- \* Tape measure

## Bolt Length Ruler

**NOTE: BOLT LENGTH IS MEASURED FROM THE UNDERSIDE OF THE HEAD OF THE BOLT.**

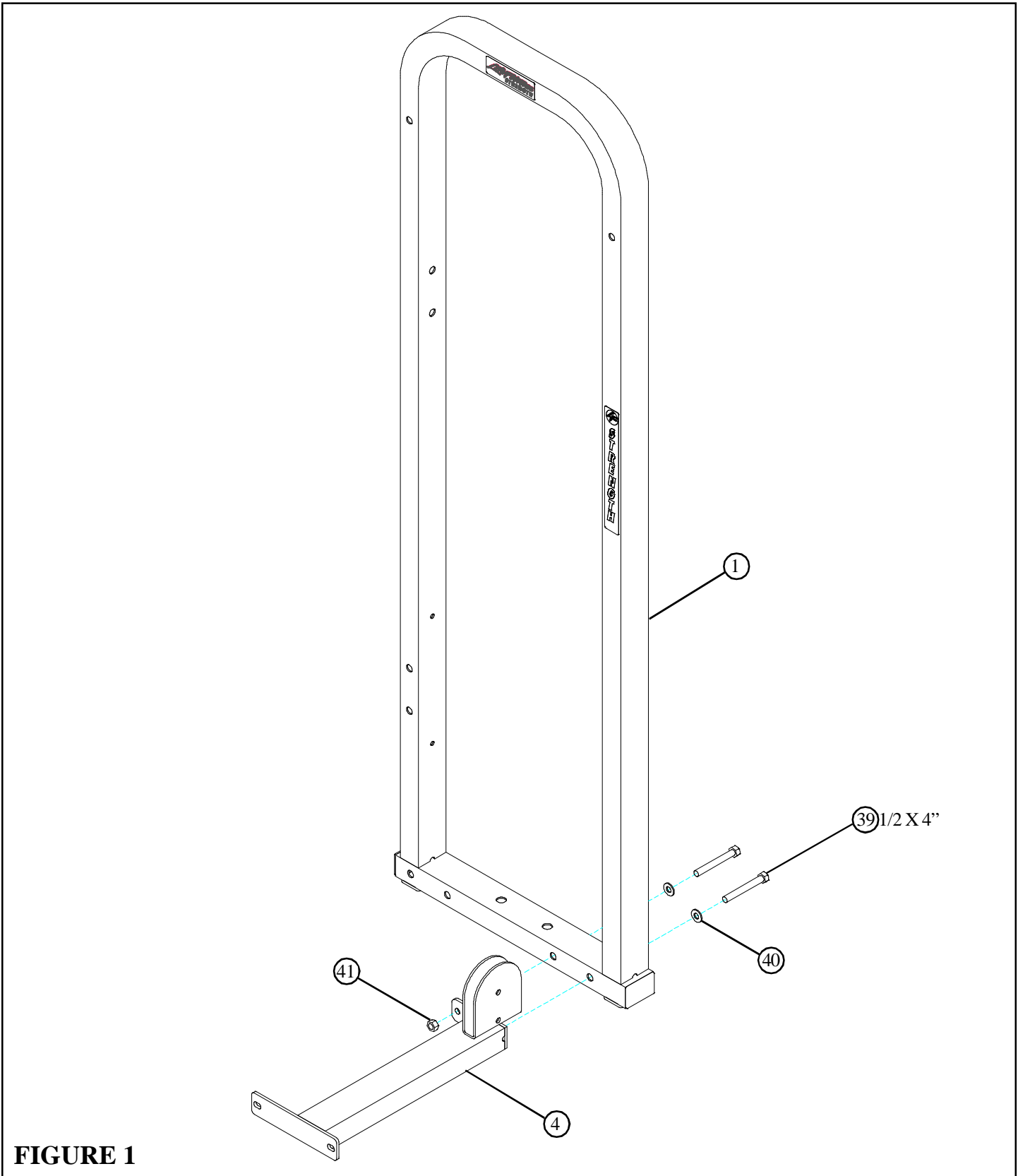


### BOLT LENGTH RULER:



# PARTS LIST

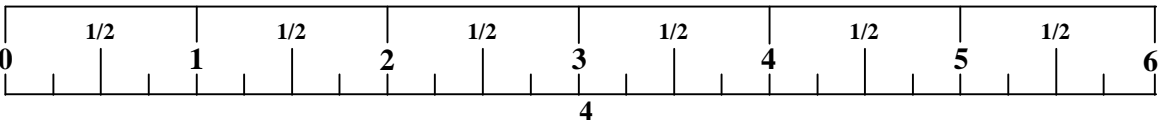
KEY	PART #	DESCRIPTION	QTY	KEY	PART #	DESCRIPTION	QTY
1	6802903	TOWER	1	23	6214401	WEIGHT STACK PIN	1
2	6804803	FRAME	1	24	6412001	SPRING PIN ASSEMBLY	1
3	6803802	FOOTPLATE	1	25	6757701	CABLE RETAINING CLIP	1
4	6780703	LOWER CROSS SUPPORT	1	26	3103302	13/16" SHAFT COLLAR	2
5	6801703	UPPER CROSS SUPPORT	1	27	6382301	WEIGHT PLATE BUSHING (QTY 10)	4
6	6804102	PIVOT FRAME	1	28	6480301	3/8" FLANGE SPACER	2
7	6803503	PIVOT ARM	1	29	6214501	WEIGHT PLATE	20
8	6781303	TOWER BRACE	1	30	3202401	3/8 X 1" BTN HEAD CAP SCREW	5
9	6802002	SEAT ADJUST	1	31	3102901	3/8 X 1-1/4" BOLT	1
10	6803203	HANDLE	1	32	3102933	3/8 X 2" BOLT	7
11	6791102	SHROUD	1	33	3102922	3/8 X 2-3/4" BOLT	1
12	6805101	PAD	2	34	3102904	3/8 X 3" BOLT	4
13	6523401	72-3/8" GUIDE ROD	2	35	3102915	3/8 X 3-1/4" BOLT	4
14	6807401	CABLE	1	36	3102501	3/8" WASHER	13
15	3116101	4-1/2" PULLEY	5	37	3102802	3/8" LOCK NUT	13
16	6284501	20 HOLE SELECTOR SHAFT	1	38	3102910	1/2 X 3" BOLT	8
17	6714601	HEAD PLATE	1	39	3102917	1/2 X 4" BOLT	16
18	3203501	PILLOW BLOCK	2	40	3102502	1/2" WASHER	24
19	6808901	2-1/2 X 9-1/2" NON-SKID STRIP	2	41	3102801	1/2" LOCK NUT	20
20	6692601	3 X 2" END CAP	1	42	6703801	WEIGHT STACK LABEL (lbs.)	1
21	3108002	2-1/2" RUBBER BUMPER	3	43	6198501	WEIGHT STACK LABELS (1-25)	1
22	6809601	1-3/4" SLEEVE	2				

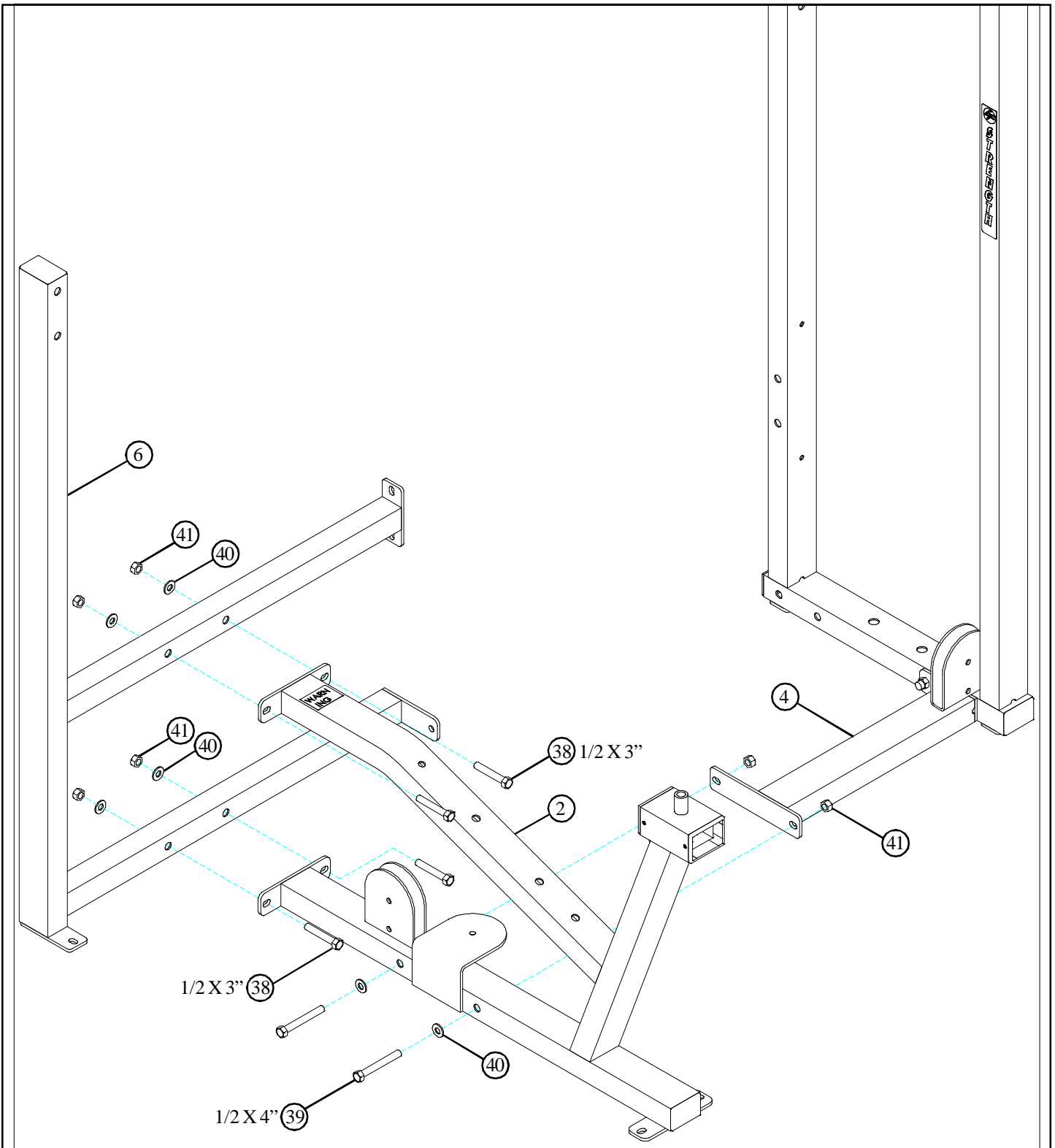


**FIGURE 1**

**STEP 1:**

- **LOOSELY** assemble LOWER CROSS SUPPORT (4) to the TOWER (1) using two 1/2 X 4" BOLTS (39), two 1/2" WASHERS (40) and one 1/2" LOCK NUT (41). See FIGURE 1.

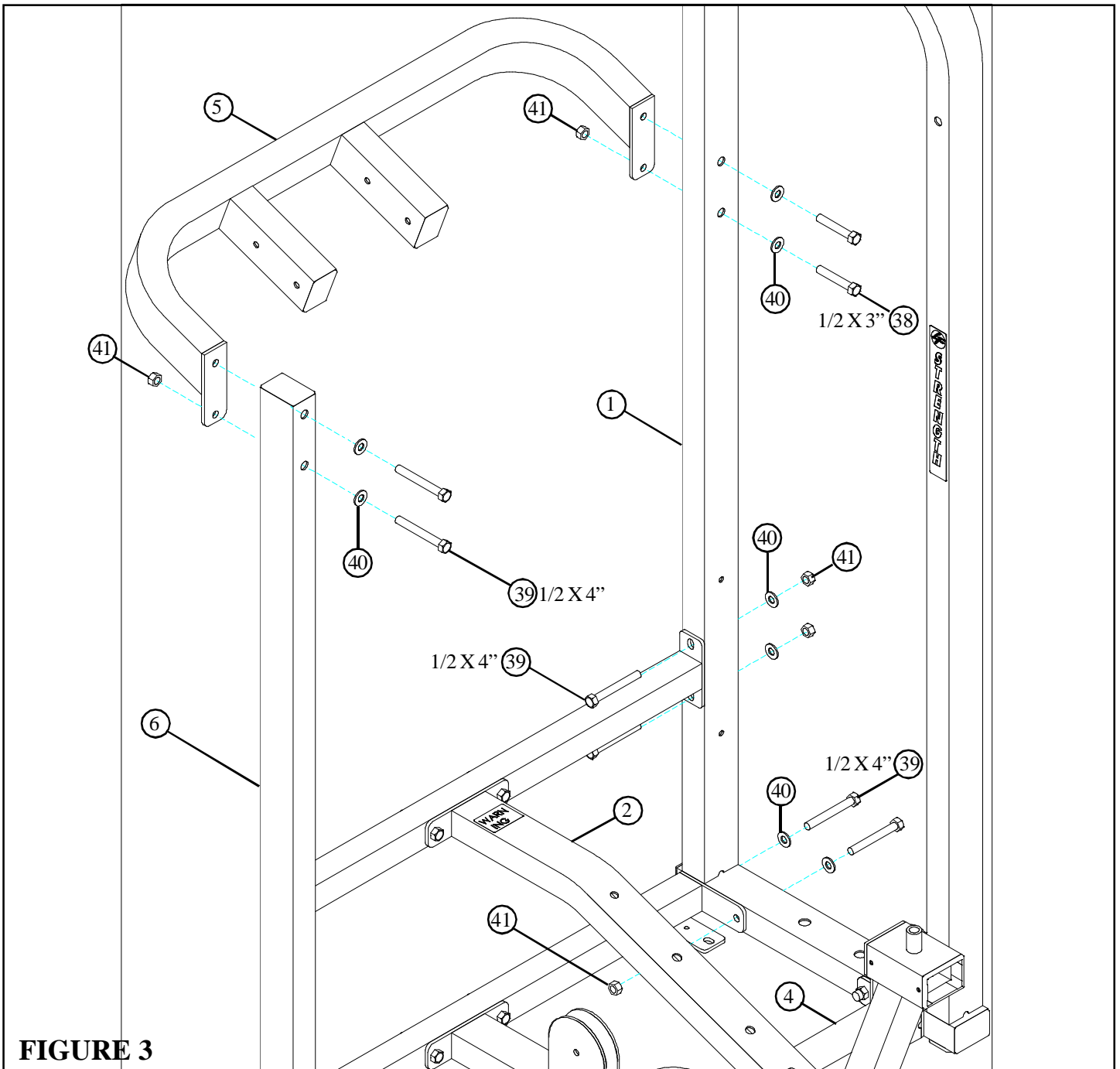




**FIGURE 2**

**STEP 2:**

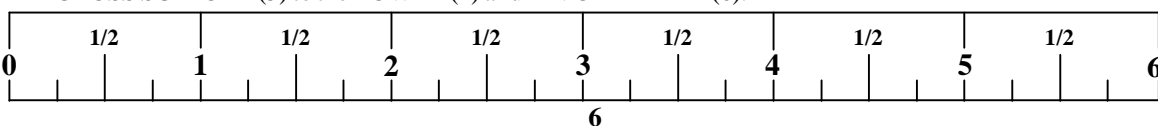
- **LOOSELY** assemble the FRAME (2) to the LOWER CROSS SUPPORT (4) using two 1/2 X 4" BOLTS (39), two 1/2" WASHERS (40) and two 1/2" LOCK NUTS (41). See FIGURE 2.
- **LOOSELY** assemble the PIVOT FRAME (6) to the FRAME (2) using four 1/2 X 3" BOLTS (38), four 1/2" WASHERS (40) and four 1/2" LOCK NUTS (41). See FIGURE 2.

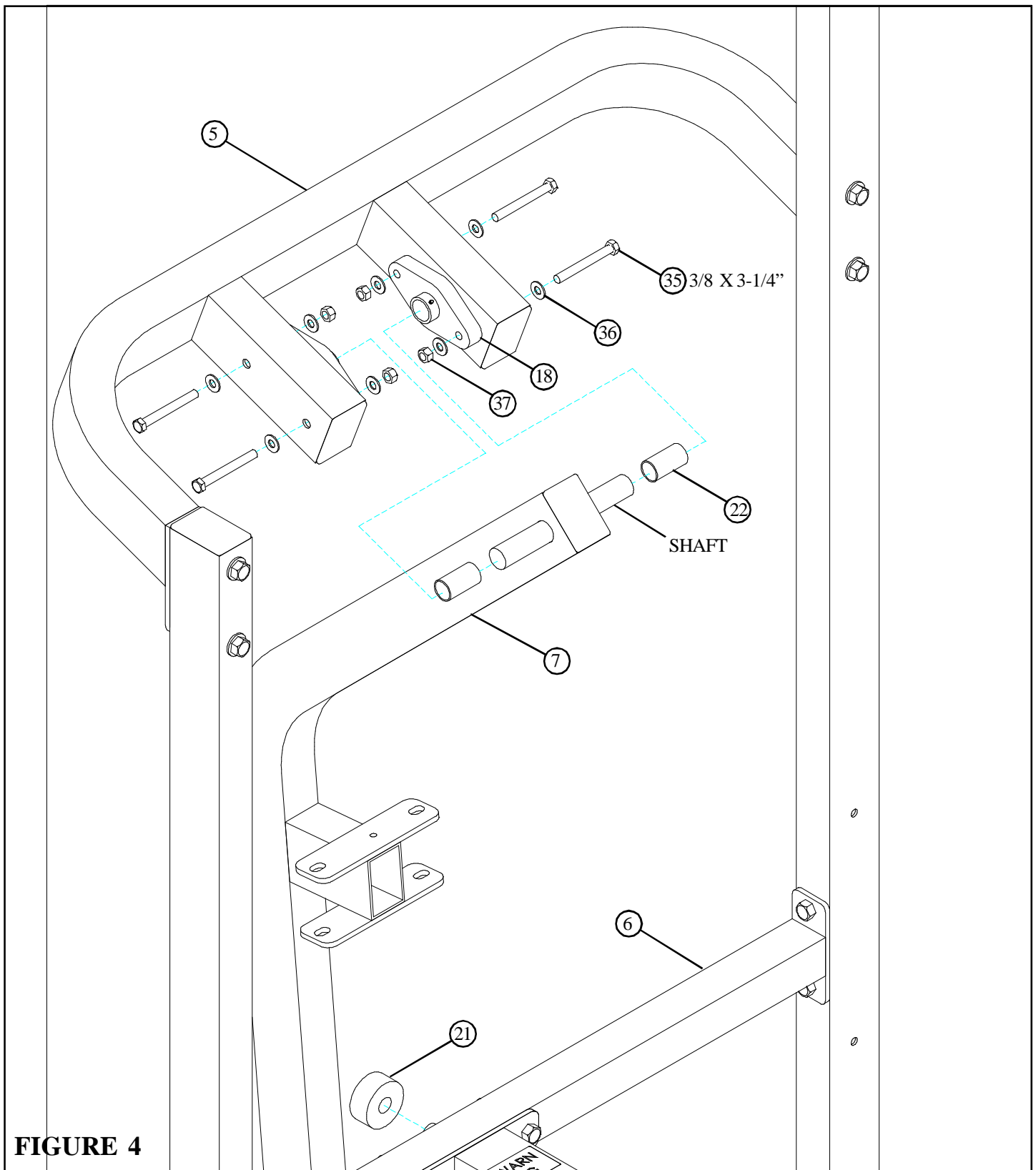


**FIGURE 3**

**STEP 3:**

- **LOOSELY** assemble the PIVOT FRAME (6) to the TOWER (1) using four 1/2 X 4" BOLTS (39), four 1/2" WASHERS (40) and three 1/2" LOCK NUTS (41) as shown in FIGURE 3.
- **LOOSELY** assemble the UPPER CROSS SUPPORT (5) to the PIVOT FRAME (6) using two 1/2 X 4" BOLTS (39), two 1/2" WASHERS (40), and one 1/2" LOCK NUT (41) while **LOOSELY** assembling the UPPER CROSS SUPPORT (5) to the TOWER (1) using two 1/2 X 3" BOLTS (38), two 1/2" WASHERS (40), and one 1/2" LOCK NUT (41) as shown in FIGURE 3.
- **SECURELY TIGHTEN THE FRAME CONNECTIONS IN THE FOLLOWING ORDER:**
  1. LOWER CROSS SUPPORT (4) to the TOWER (1) and FRAME (2).
  2. PIVOT FRAME (6) to the TOWER (1) and FRAME (2).
  3. UPPER CROSS SUPPORT (5) to the TOWER (1) and PIVOT FRAME (6).

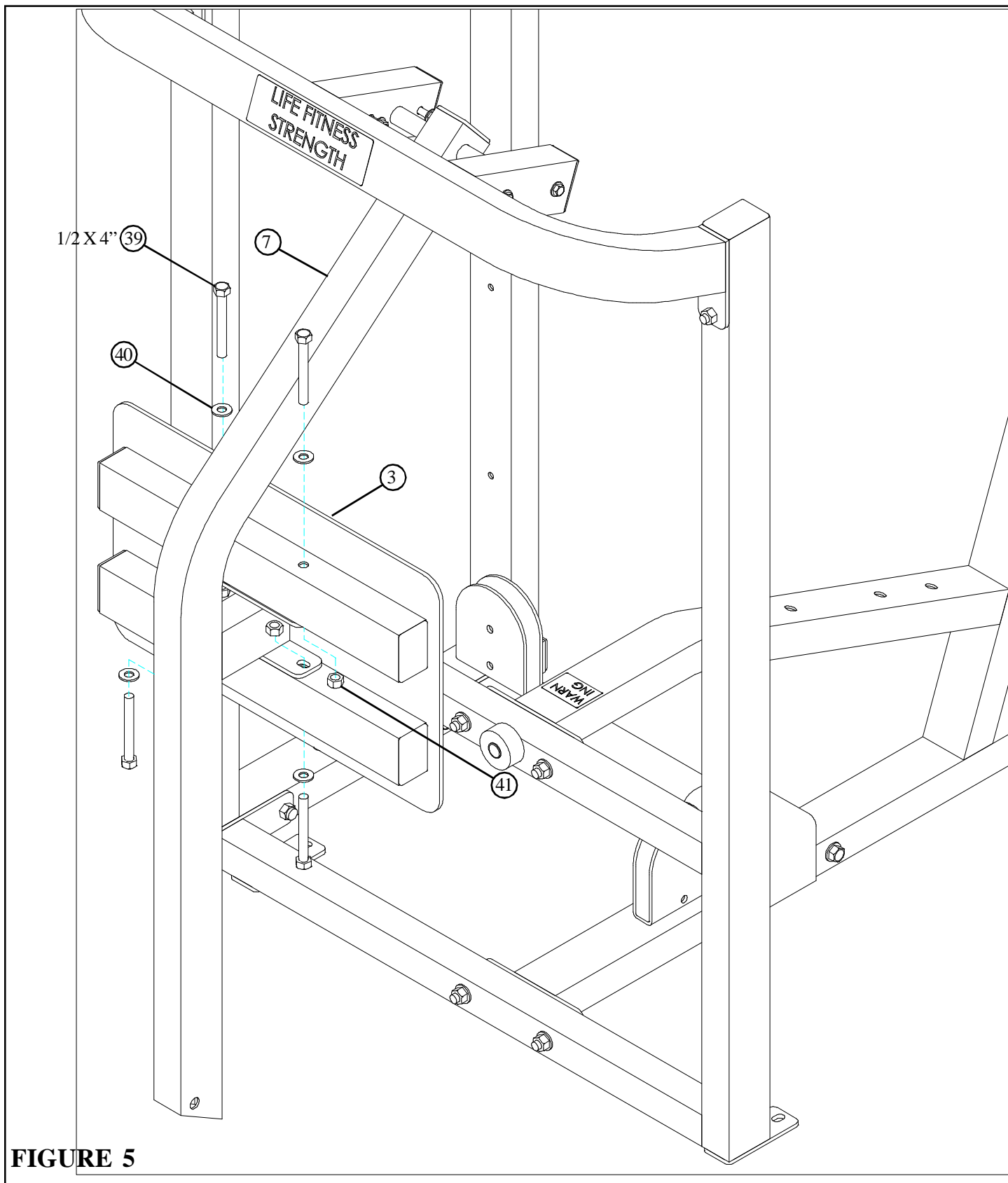




**FIGURE 4**

**STEP 4:**

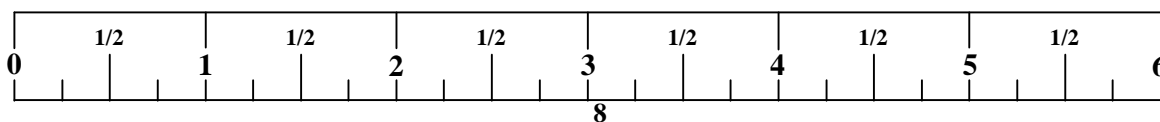
- Slide one RUBBER BUMPER (21) over the short round tube on the PIVOT FRAME (6) as shown in FIGURE 4.
- Slide two 1-3/4" VINYL SLEEVES (22) over the shafts on the PIVOT ARM (7) as shown in FIGURE 4.
- Slide two PILLOW BLOCKS (18) over the shaft on the PIVOT ARM (7) and **SECURELY** assemble the two PILLOW BLOCKS (18) to the UPPER CROSS SUPPORT (5) using four 3/8 X 3-1/4" BOLTS (35), four 3/8" WASHERS (36), and four 3/8" LOCK NUTS (37) as shown in FIGURE 4.
- Center PIVOT ARM (7) and securely tighten set screws on the PILLOW BLOCKS (18). See FIGURE 4.



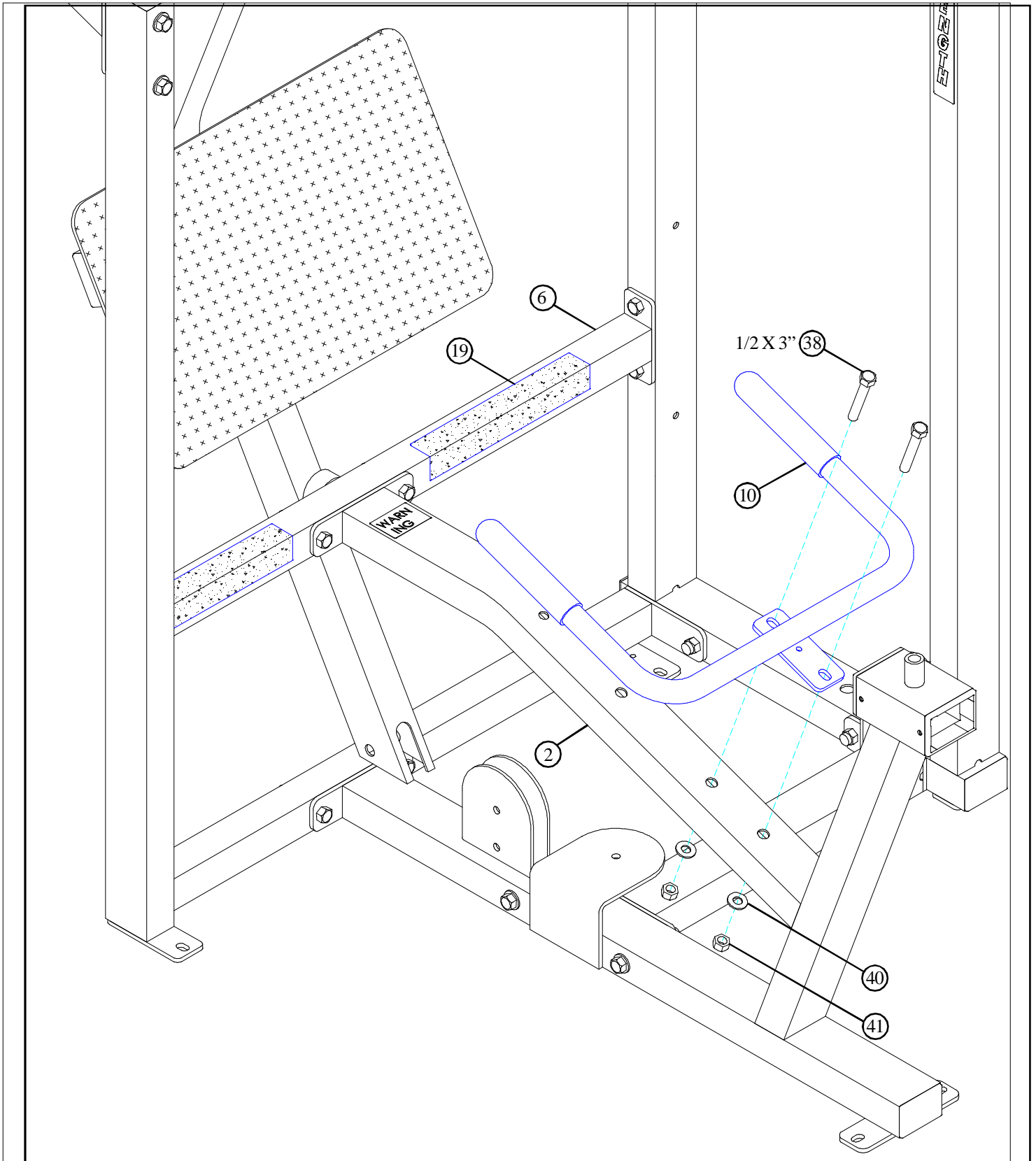
**FIGURE 5**

**STEP 5:**

- **SECURELY** assemble the FOOTPLATE (3) to the PIVOT ARM (7) using four 1/2 X 4" BOLTS (39), four 1/2" WASHERS (40), and four 1/2" LOCK NUTS (41) as shown in FIGURE 5.



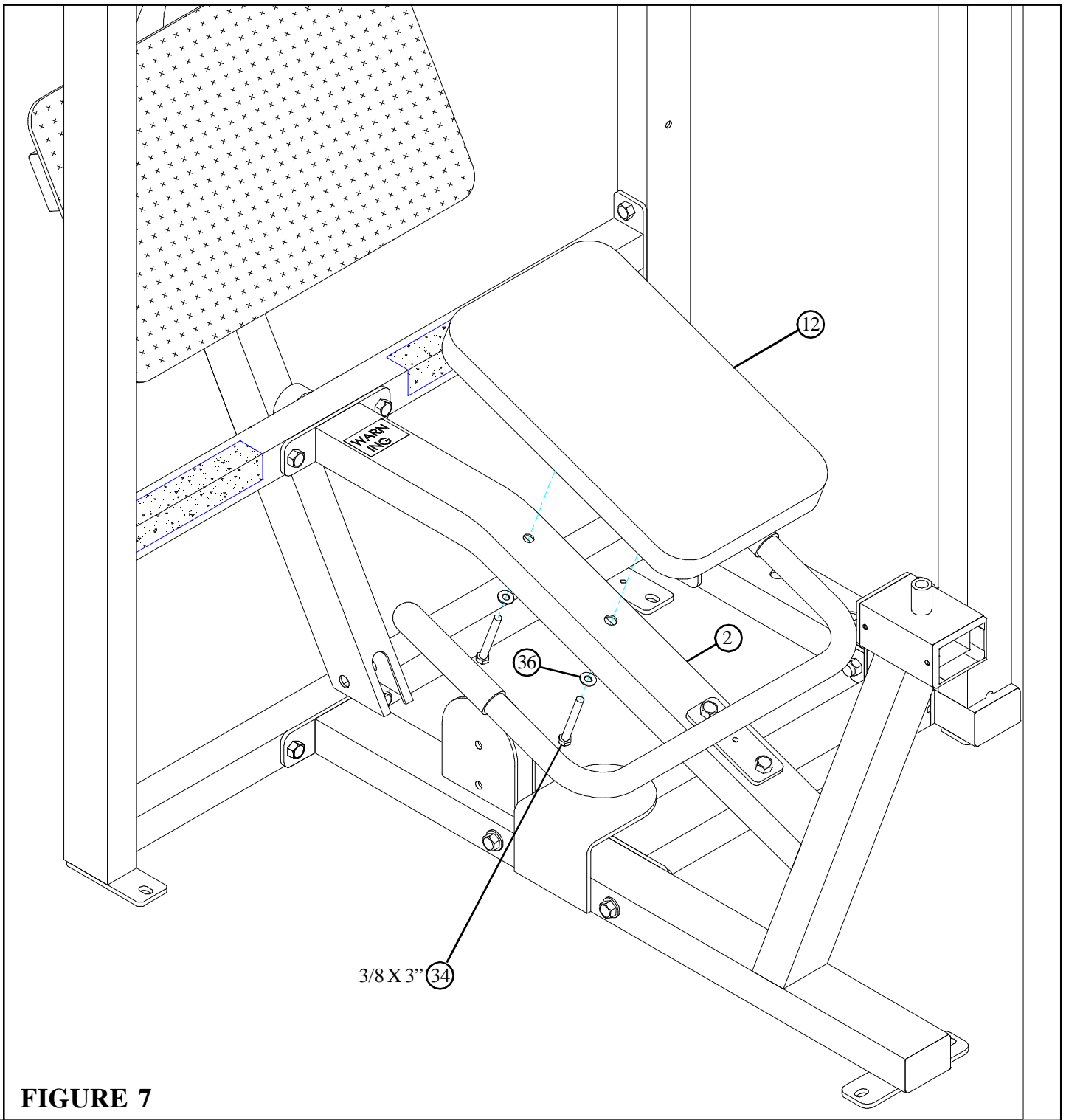




**FIGURE 6**

**STEP 6:**

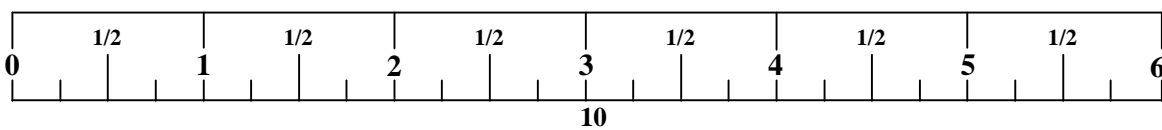
- **SECURELY** assemble the HANDLE (10) to the FRAME (2) using two 1/2 X 3" BOLTS (38), two 1/2" WASHERS (40), and two 1/2" LOCK NUTS (41) as shown in FIGURE 6.
- Apply two 2-1/2 X 9-1/2" NON-SKID STRIPS (19) a foot stance apart on the PIVOT FRAME (6) as shown in FIGURE 6.

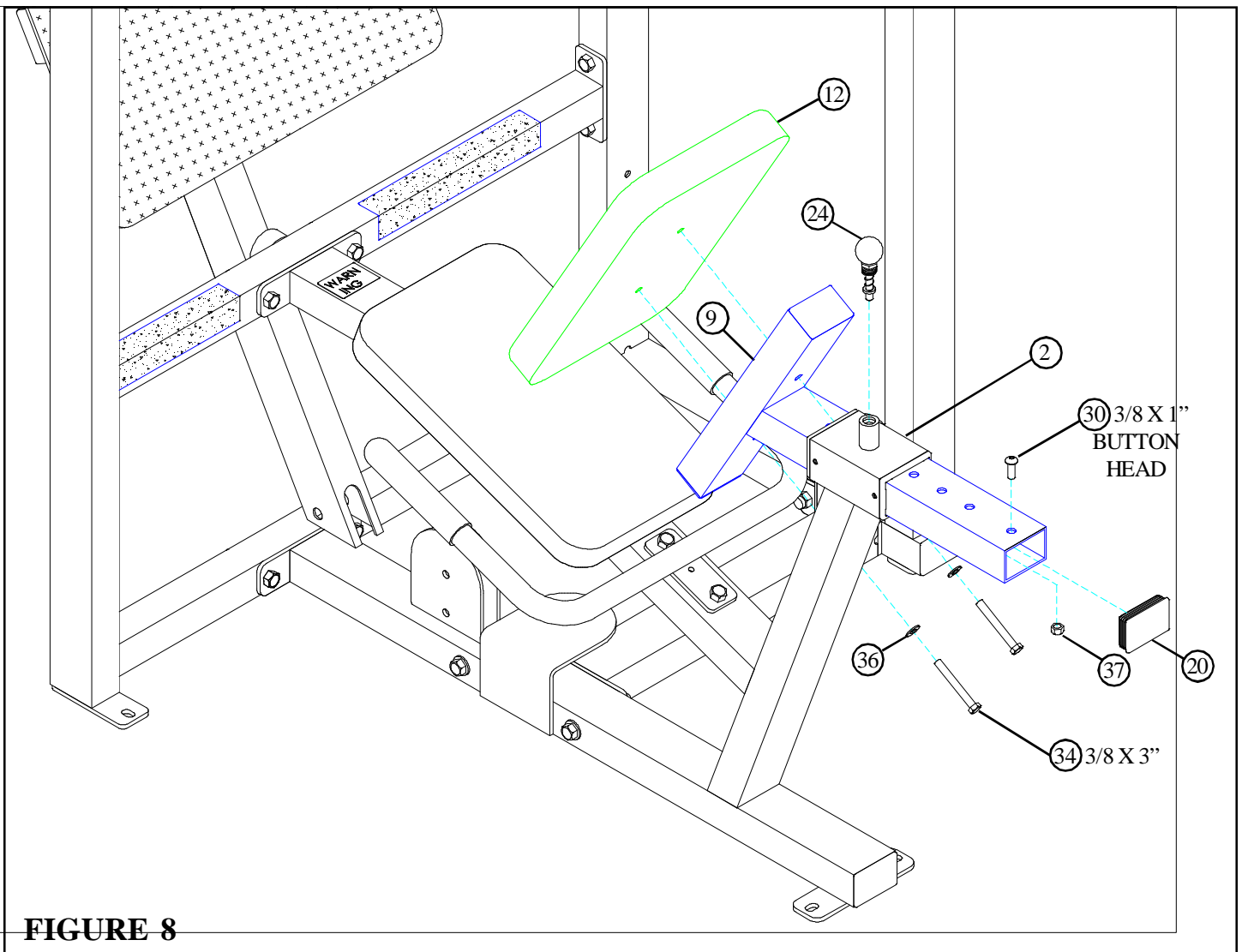


**FIGURE 7**

**STEP 7:**

- **SECURELY** assemble one PAD (12) to the FRAME (2) using two 3/8 X 3" BOLTS (34) and two 3/8" WASHERS (36) as shown in FIGURE 7.





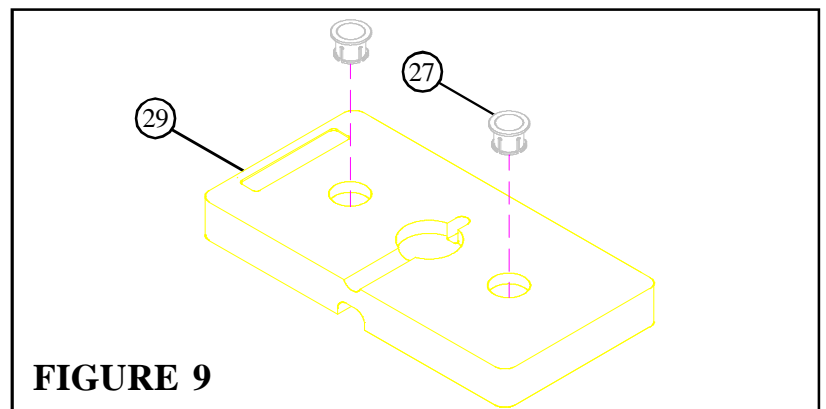
**FIGURE 8**

**STEP 8:**

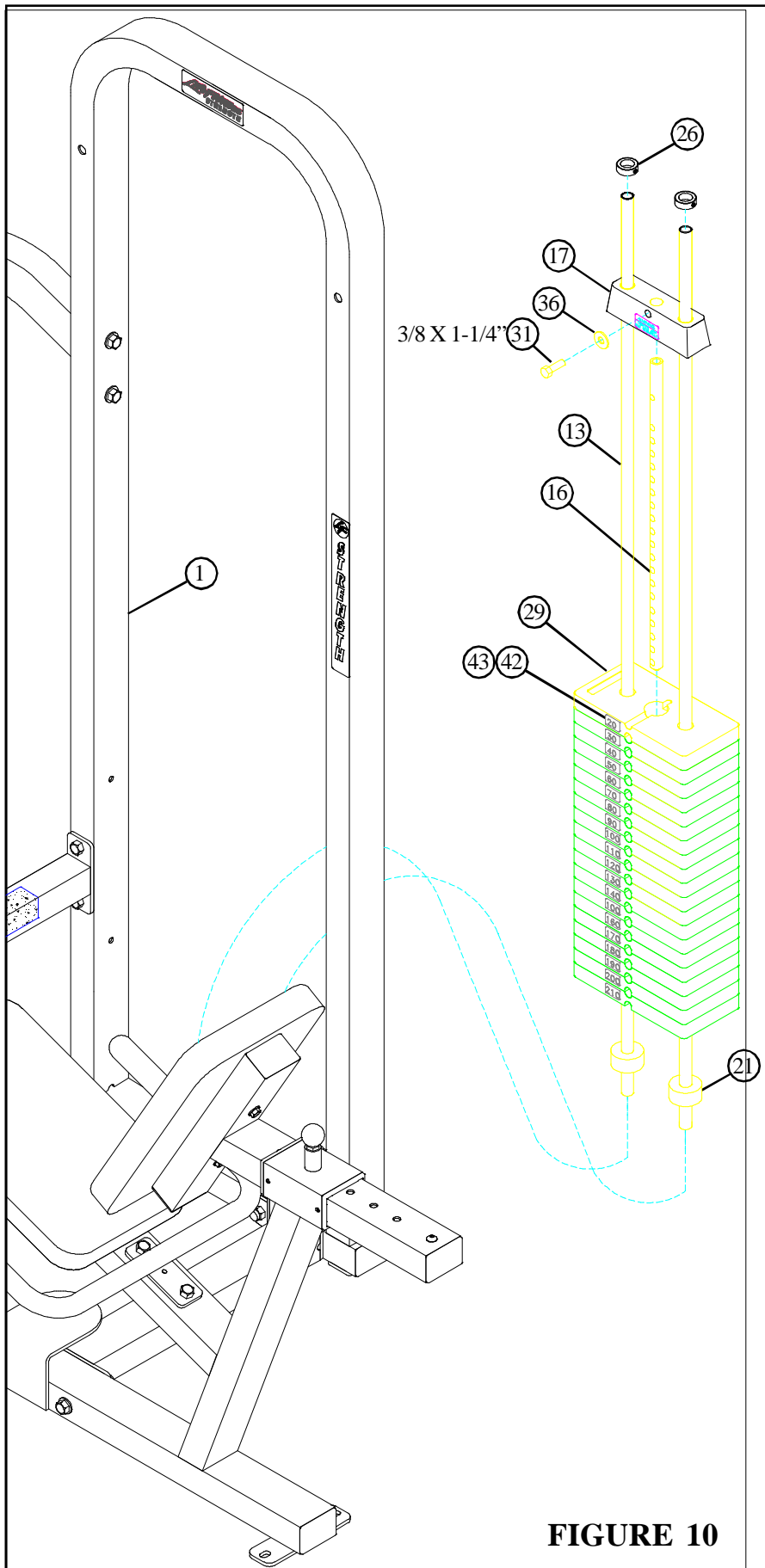
- **SECURELY** assemble the SEAT PAD (12) to the SEAT ADJUST (9) using two 3/8 X 3" BOLTS (34) and two 3/8" WASHERS (36). See FIGURE 8.
- **SECURELY** assemble one SPRING PIN ASSEMBLY (24) to the spring pin barrel on the FRAME (2) as shown in FIGURE 8.
- Insert the PAD (12) & SEAT ADJUST (9) into the FRAME (2) while pulling back on the SPRING PIN ASSEMBLY (24) until it engages in one of the adjustment holes. See FIGURE 8.
- **SECURELY** assemble one 3/8" X 1" BUTTON HEAD CAP SCREW (30) and one 3/8" LOCK NUT (37) to the last hole on the SEAT ADJUST (9). See FIGURE 8.
- **SECURELY** insert one 3 X 2" SQ. END CAP (20) to the open end of the SEAT ADJUST (9). See FIGURE 8.

**STEP 9:**

- Snap two WEIGHT PLATE BUSHINGS (27) into the top of all twenty WEIGHT PLATES (29) as shown in FIGURE 9.



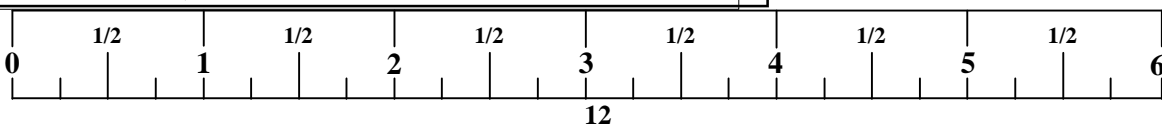
**FIGURE 9**

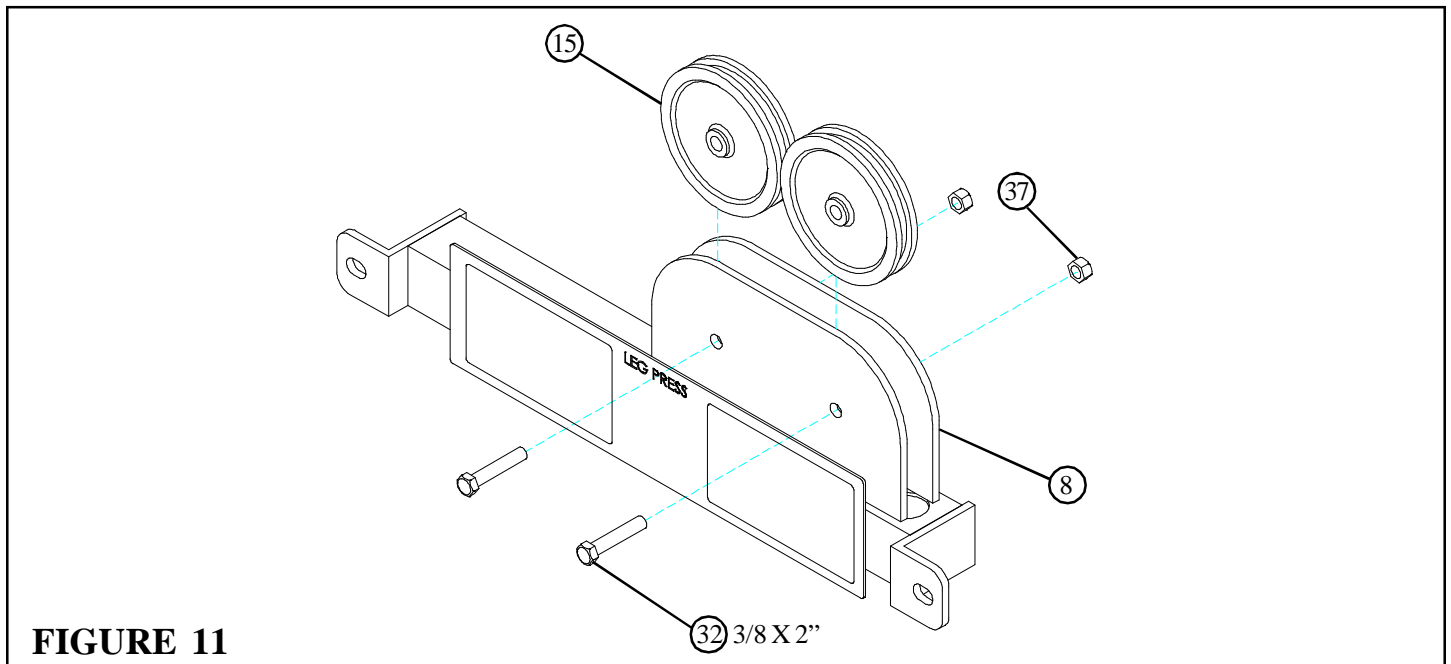


## STEP 12:

- Insert two GUIDE RODS (13) into the base of the TOWER (1) as shown in FIGURE 10. Lubricate the GUIDE RODS (13) with a silicon or teflon spray that is available at most hardware stores.
- Slide two RUBBER BUMPERS (21) down over the GUIDE RODS (13). See FIGURE 10.
- Using **EXTREME CARE** slide twenty WEIGHT PLATES (29) down over the GUIDE RODS (13) with the key-hole facing as shown in FIGURE 10.
- Securely assemble the 20 HOLE SELECTOR SHAFT (16) to the HEAD PLATE (17) using one 3/8 X 1-1/4" BOLT (31) and one 3/8" WASHER (36). (**Note: The bolt hole in the HEAD PLATE (17) should be on top.**)
- Carefully Slide the HEAD PLATE ASSEMBLY (16 & 17) down over the GUIDE RODS (13) onto the weight stack as shown in FIGURE 10.
- Slide two 13/16" SHAFT COLLARS (26) over the GUIDE RODS (13) as shown in FIGURE 10.
- Apply one set of WEIGHT STACK LABELS - LBS. OR 1-25 (42) (43) to each WEIGHT PLATE (29) as shown in FIGURE 10.

**FIGURE 10**

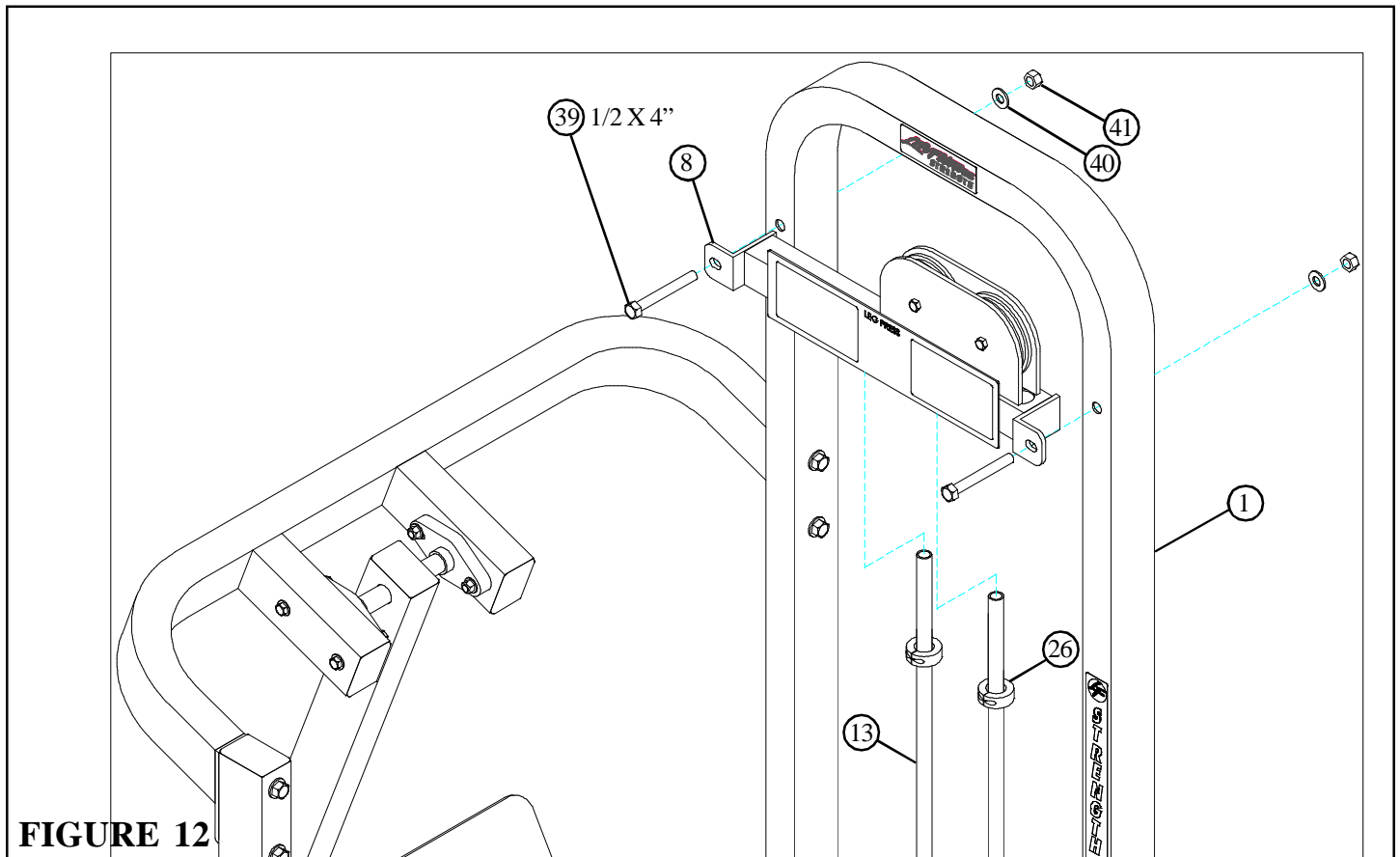




**FIGURE 11**

**STEP 11:**

- **SECURELY** assemble two 4-1/2" PULLEYS (15) to the TOWER BRACE (8) using two 3/8 X 2" BOLTS (32), and two 3/8" LOCK NUTS (37). See FIGURE 11.

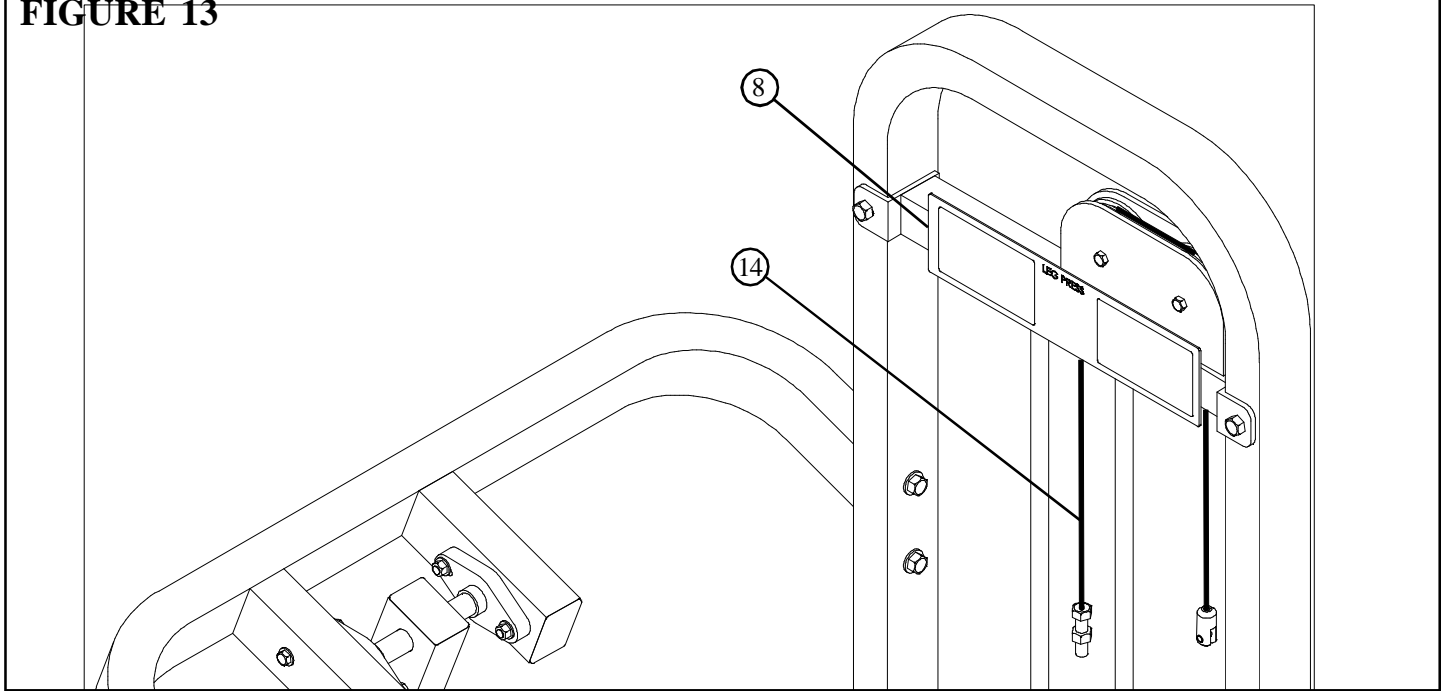


**FIGURE 12**

**STEP 12:**

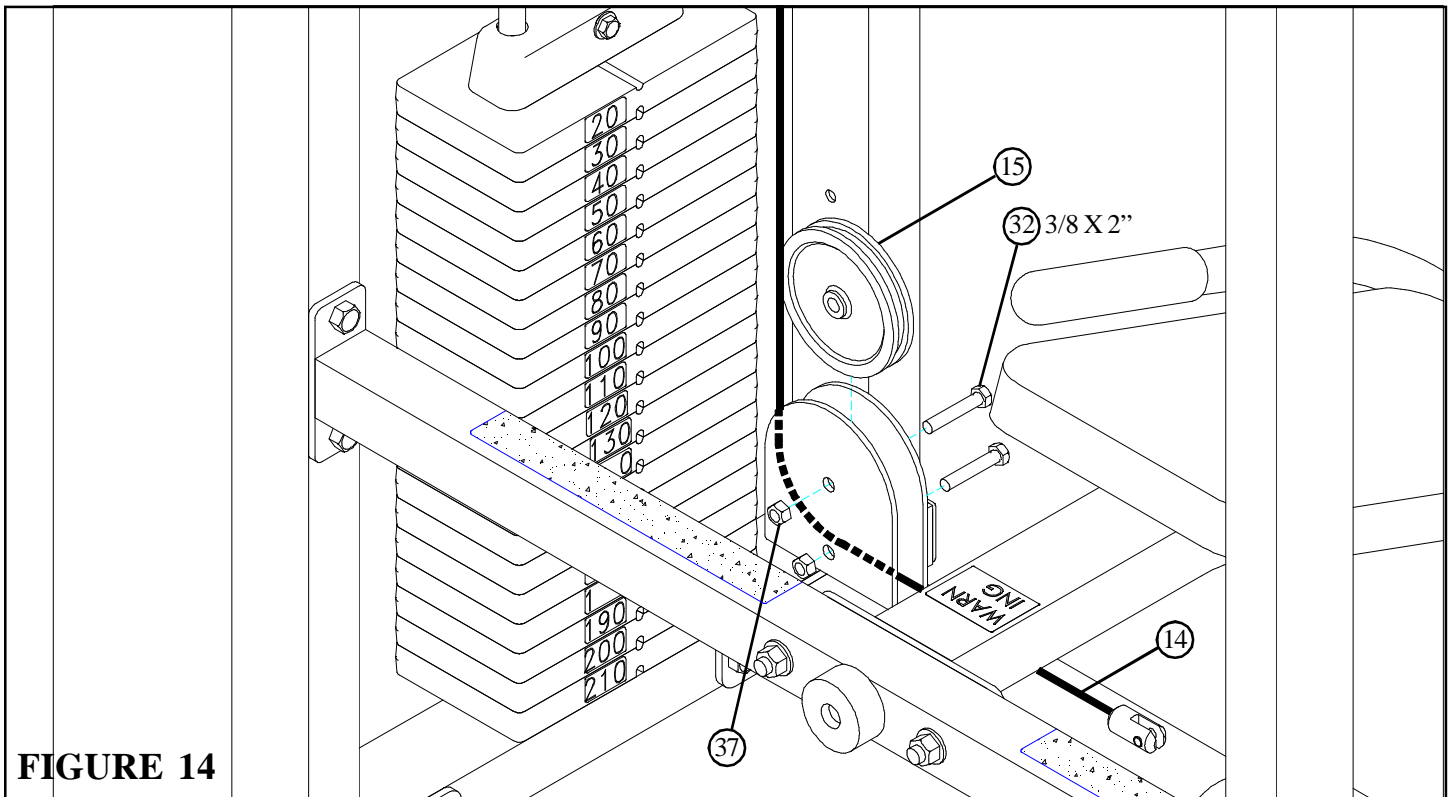
- Place TOWER BRACE (8) over the GUIDE RODS (13) and **SECURELY** assemble TOWER BRACE (8) to TOWER (1) using two 1/2 X 4" BOLTS (39), two 1/2" WASHERS (40), and two 1/2" LOCK NUTS (41) as shown in FIGURE 12.
- Slide the 13/16" SHAFT COLLARS (26) to the top of the GUIDE RODS (13) and **SECURELY** tighten the SHAFT COLLAR (26) set screws. See FIGURE 12.

**FIGURE 13**



**STEP 13:**

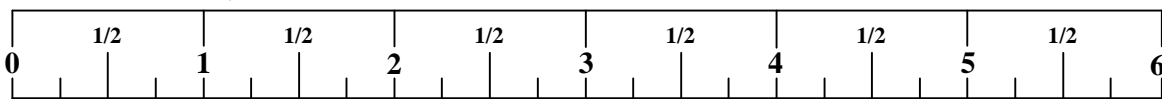
- Route the swivel end of the CABLE (14) through the holes and around the pulleys in the TOWER BRACE (8) as shown in FIGURE 13.

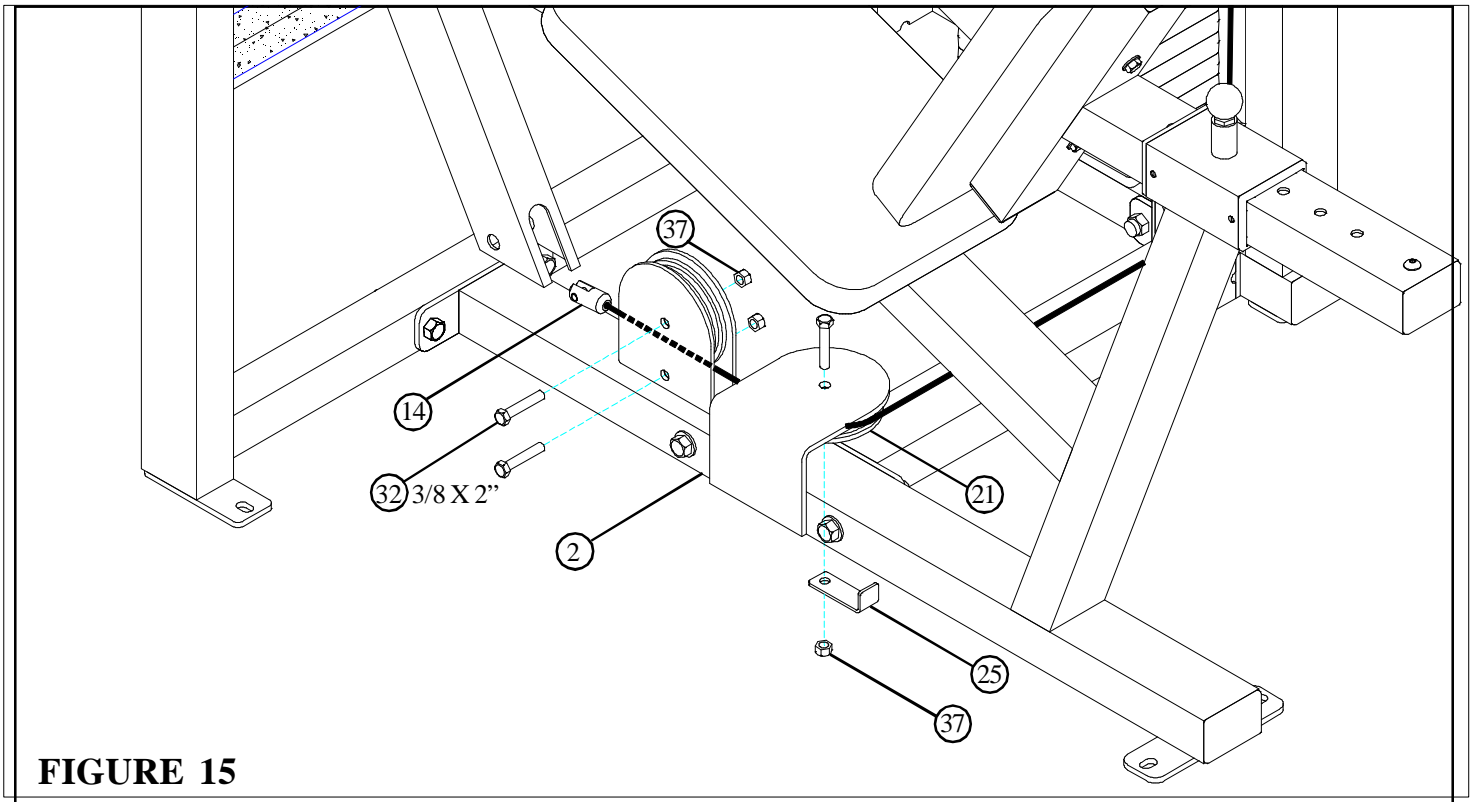


**FIGURE 14**

**STEP 14:**

- Route the CABLE (14) around one 4-1/2\" PULLEY (15) and assemble the pulley to the bracket on the LOWER CROSS SUPPORT (4), using two 3/8 X 2\" BOLTS (32), and two 3/8\" LOCK NUTS (37) as shown in FIGURE 14. (NOTE: Make sure CABLE is running over 3/8 X 2\" RETAINING BOLT.)

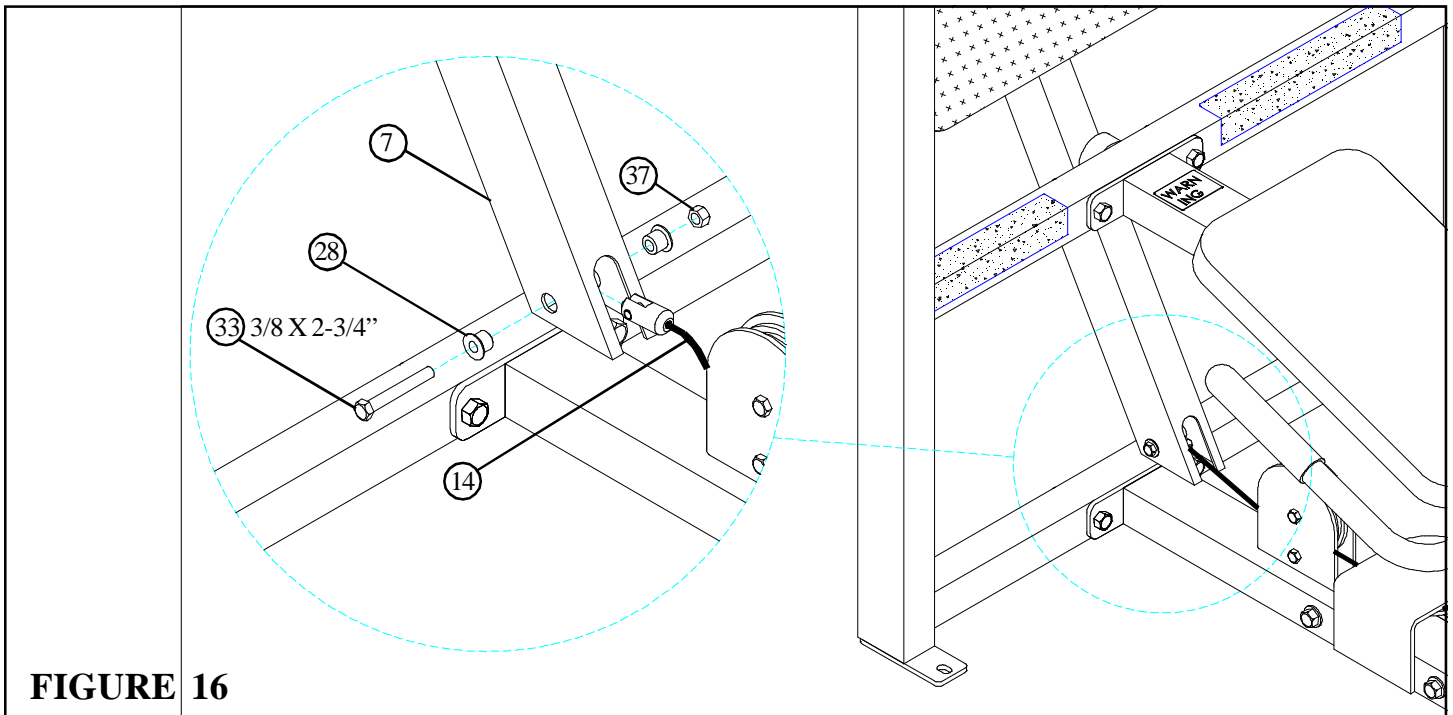




**FIGURE 15**

**STEP 15:**

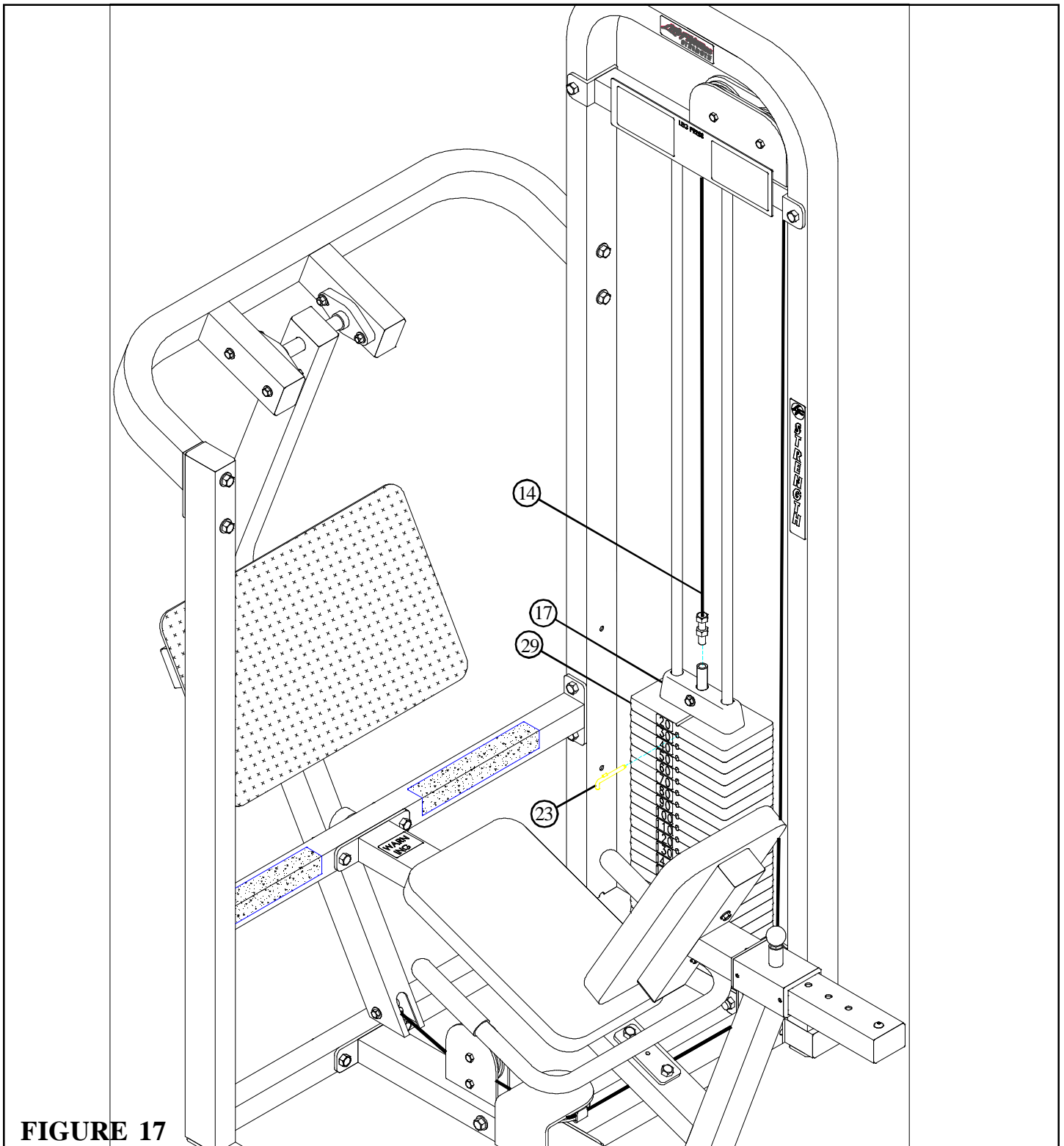
- **SECURELY** assemble two 4-1/2" PULLEYS (21) to the brackets on the FRAME (2) using three 3/8 X 2" BOLTS (32), one CABLE RETAINING CLIP (25), and three 3/8" LOCK NUTS (37) as shown in FIGURE 16. (NOTE: Position the CABLE RETAINING CLIP before tightening.)
- Make sure the CABLE (14) is routed around all pulleys as shown in FIGURE 16.



**FIGURE 16**

**STEP 16:**

- **SECURELY** assemble the swivel end of the CABLE (14) to the PIVOT ARM (7) using one 3/8 X 2-3/4" BOLTS (33), two 3/8" FLANGE SPACERS (28) and one 3/8" LOCK NUT (37) as shown in FIGURE 16.

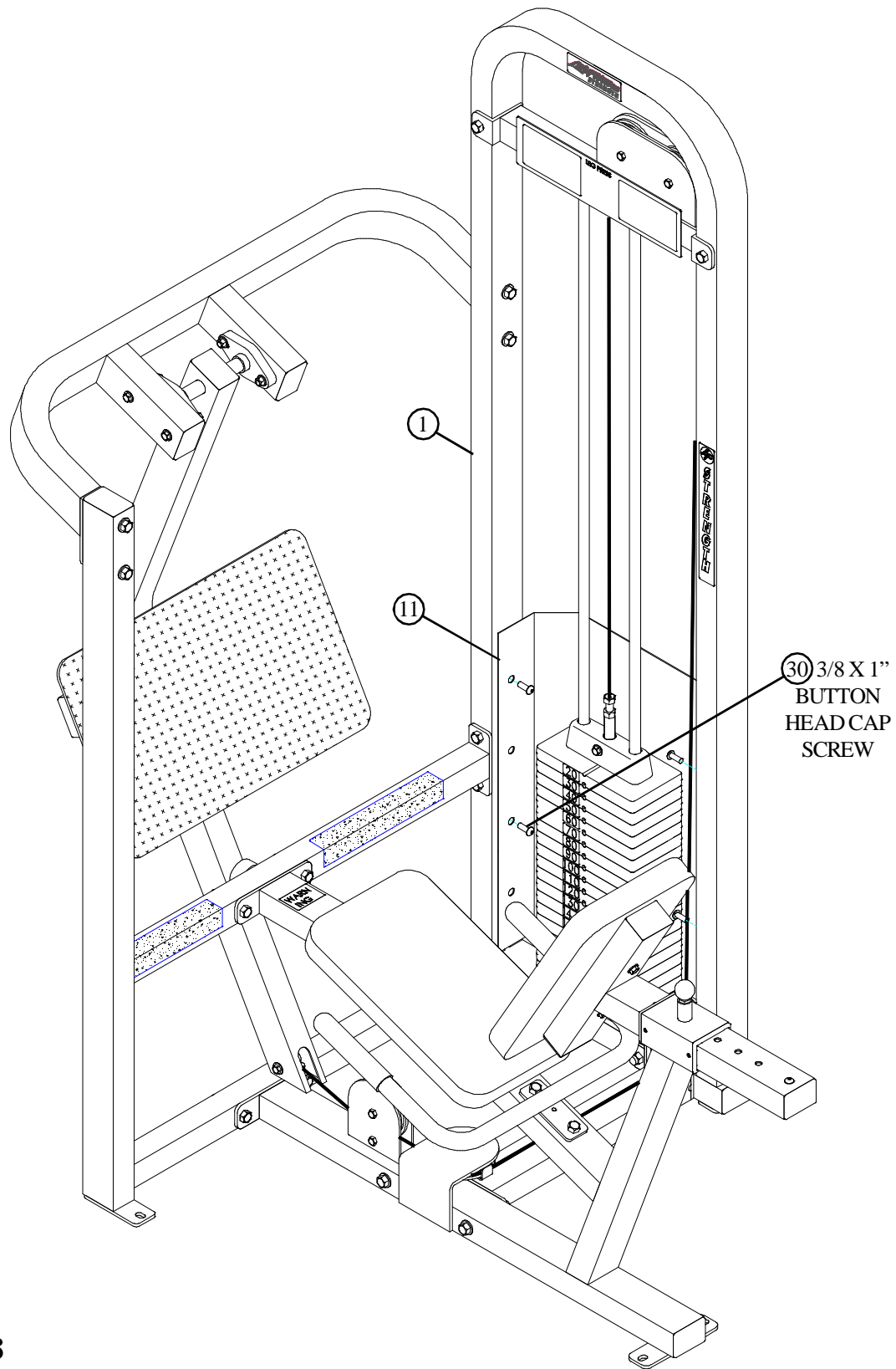


**FIGURE 17**

**STEP 17:**

- Screw the threaded end of the CABLE (14) approximately 3/4" into the end of the 20 HOLE SELECTOR SHAFT (16) and tighten jam nut securely. See FIGURE 17.
- If the HEAD PLATE (17) does not sit on top of the first WEIGHT PLATE (29), push the head plate down, insert the SELECTOR PIN (23) and perform several repetitions on the machine. This will relax the cable system and prevent the HEAD PLATE (17) from lifting up.
- If after completing the previous step the HEAD PLATE (17) still does not sit on top of the first WEIGHT PLATE (29) or if there is excess slack in the cable system, adjust the threaded end of the CABLE accordingly and retighten the jam nut.





**FIGURE 18**

**STEP 18:**

- **SECURELY** assemble the SHROUD (11) to the TOWER (1) using four 3/8 X 1" BUTTON HEAD CAP SCREWS (30) as shown in FIGURE 18.

**Thank you for purchasing the LifeFitness 8245 LEG PRESS/CALF. If unsure of proper use of equipment, call your local LifeFitness distributor or call the LifeFitness customer service department at (800) 328-9714.**

## Free Manuals Download Website

<http://myh66.com>

<http://usermanuals.us>

<http://www.somanuals.com>

<http://www.4manuals.cc>

<http://www.manual-lib.com>

<http://www.404manual.com>

<http://www.luxmanual.com>

<http://aubethermostatmanual.com>

Golf course search by state

<http://golfingnear.com>

Email search by domain

<http://emailbydomain.com>

Auto manuals search

<http://auto.somanuals.com>

TV manuals search

<http://tv.somanuals.com>