

Serious Steel

965101

**FLAT & INCLINE BENCH
ASSEMBLY INSTRUCTIONS**

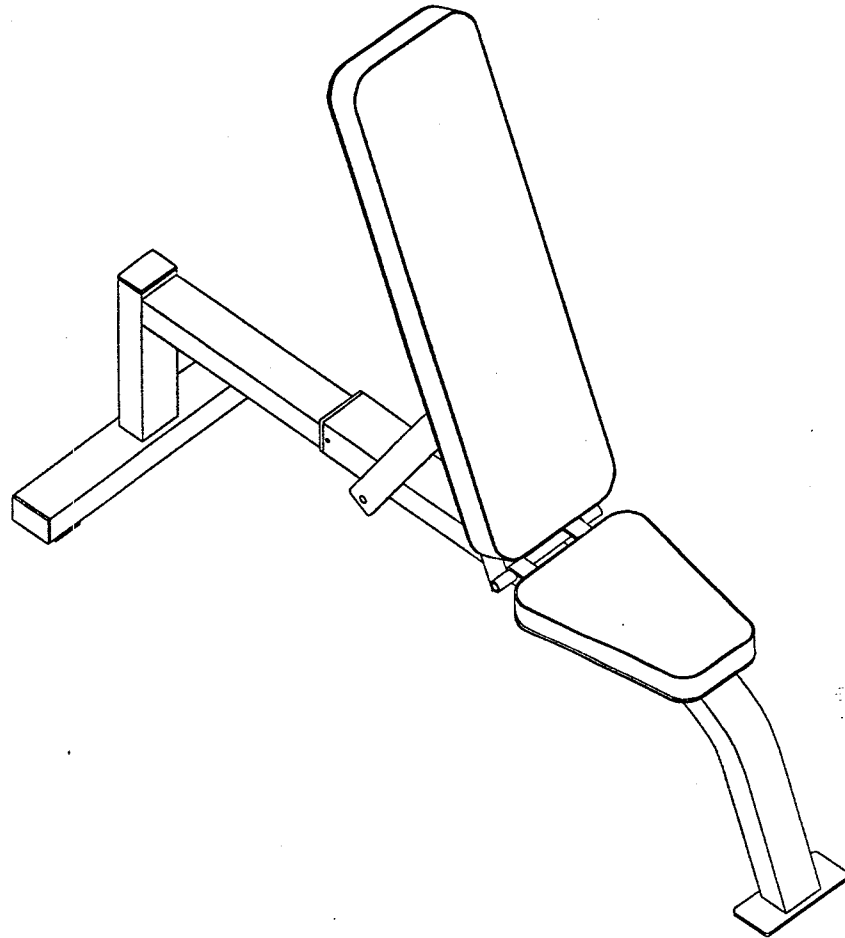

ParaBody, Incorporated
14150 Sunfish Lake Boulevard
Ramsey, MN 55303
1-800-328-9714

Part # 6653501

1

Revision: 11/26/96

965101 FLAT & INCLINE BENCH ASSEMBLY PARTS LIST

SORT AND COUNT ALL PARTS BEFORE BEGINNING ASSEMBLY

HARDWARE:

ITEM	NAME/DESCRIPTION	QTY
1.	1/2 X 9-1/2 IN BOLT	1
2.	1/2 X 6-1/2 IN BOLT	1
3.	1/2 X 3 IN BOLT	2
4.	1/2 X 1-1/4 IN BOLT	2
5.	3/8 X 1 IN BOLT	6
6.	1/2 IN WASHER	6
7.	3/8 IN WASHER	6
8.	1/2 IN LOCK NUT	3
9.	1/2 IN LOW HEIGHT LOCK NUT	3
10.	HINGE TAB	2
11.	6-1/8 X 3-7/8 IN U-PIN	1
12.	1/2 ID X 5/8 IN SPACER	1
13.	SPRING PIN ASSEMBLY	1
14.	1/2 IN ID CAPNUT	1
15.	3 X 2 IN INSERT GUIDE	2
16.	3 X 2 IN END CAP	3
17.	7/16 ID X 4 IN VINYL CAP	1

WELDMENTS/PARTS:

ITEM	NAME/DESCRIPTION	QTY
1.	REAR UPRIGHT WELDMENT (6651703)	1
2.	BENCH FRAME WELDMENT (6652103)	1
3.	ADJ SLEEVE WELDMENT (6652803)	1
4.	BACK PAD ANGLE WELDMENT LEFT (6624202)	1
5.	BACK PAD ANGLE WELDMENT RIGHT (6624302)	1
6.	1/2 X 2 X 15-1/2 IN PLATE (6651602)	2
7.	SEAT PAD 66353XX (66535XX)	1
8.	BACK PAD (66529XX)	1

NOTE: BOLT LENGTH IS MEASURED FROM THE UNDERSIDE OF THE HEAD OF THE BOLT.

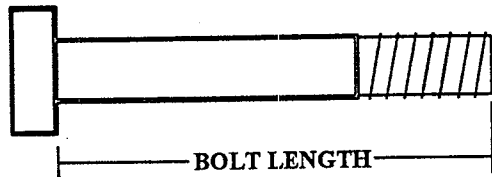

BOLT LENGTH RULER:

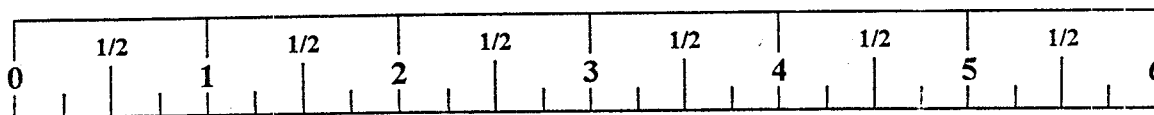

965101 FLAT & INCLINE BENCH ASSEMBLY INSTRUCTIONS

THANK YOU

FOR PURCHASING THE *965101 FLAT & INCLINE BENCH*. PLEASE SAVE THESE ASSEMBLY INSTRUCTIONS FOR YOUR PERSONAL REFERENCE, AND ADDITIONAL SERVICE INFORMATION.

IMPORTANT

- THE *965101 FLAT & INCLINE BENCH* MUST BE ASSEMBLED ON A FLAT, LEVEL SURFACE TO ASSURE ITS PROPER FUNCTION.
- IF YOU EXPERIENCE ANY PROBLEM WITH THE ASSEMBLY OF THIS PRODUCT, PLEASE CONTACT YOUR DEALER OR YOUR PARABODY CUSTOMER SERVICE REPRESENTATIVE AT: 1-800-328-9714
- **TOOLS REQUIRED:** RATCHET, 3/4 SOCKET and WRENCH, 9/16 SOCKET and WRENCH, and RUBBER MALLET or HAMMER.

1. Slide one (1) 7/16 ID X 4 IN VINYL CAP onto the 6-1/8 X 3-7/8 IN U-PIN and proceed to assemble it to the **BENCH FRAME WELDMENT** as shown on drawing.
2. Insert two (2) 3 X 2 INSERT GUIDES into each end of the **ADJ SLEEVE WELDMENT** as shown on drawing. (NOTE: MAKE SURE THE INSERT GUIDES SNAP INTO THE HOLES OF THE WELDMENT). SECURELY assemble the SPRING PIN ASSEMBLY to the **ADJ SLEEVE WELDMENT** as shown in (DETAIL A).
3. Pull back the SPRING PIN on the **ADJ SLEEVE WELDMENT** and slide it over the end of the **BENCH FRAME WELDMENT** as shown on drawing. Slide WELDMENT up to the first adjustment hole underneath.
4. Insert three (3) 3 X 2 IN END CAPS into the ends of the **REAR UPRIGHT WELDMENT** as shown on drawing.
5. SECURELY assemble the **REAR UPRIGHT WELDMENT** to the **BENCH FRAME WELDMENT** as shown on drawing.
6. Assemble the **LEFT** and **RIGHT BACK PAD ANGLE WELDMENTS**, along with two (2) **HINGE TABS** to the **BENCH FRAME WELDMENT** as shown on drawing. (NOTE: TIGHTEN CONNECTION ENOUGH TO REMOVE THE PLAY YET ALLOWING THE PARTS TO ROTATE FREELY).
7. Assemble two (2) 1/2 X 2 X 15-1/2 IN PLATES to the inside of the **LEFT** and **RIGHT BACK PAD ANGLE WELDMENTS** as shown on drawing. (NOTE: TIGHTEN CONNECTION ENOUGH TO REMOVE THE PLAY YET ALLOWING THE PARTS TO ROTATE FREELY).
8. Rotate the **LEFT** and **RIGHT BACK PAD ANGLE WELDMENTS** up and assemble the 1/2 X 2 X 15-1/2 IN PLATES to the **ADJ SLEEVE WELDMENT** as shown on drawing. (NOTE: DO NOT OVER TIGHTEN THIS CONNECTION).

965101 FLAT & INCLINE BENCH ASSEMBLY INSTRUCTIONS

9. **SECURELY** assemble the **BACK PAD** to the **LEFT** and **RIGHT BACK PAD ANGLE WELDMENTS** as shown on drawing.
10. **SECURELY** assemble the **SEAT PAD** to the **HINGE TABS** on the **BENCH FRAME WELDMENT** as shown on drawing.

REVISIONS				
REV	DESCRIPTION	CHG NO	APP'D	DATE
C	WAS 4-3/8	3001	DLm	11/96

DASH NO	DESCRIPTION
01	AS SHOWN

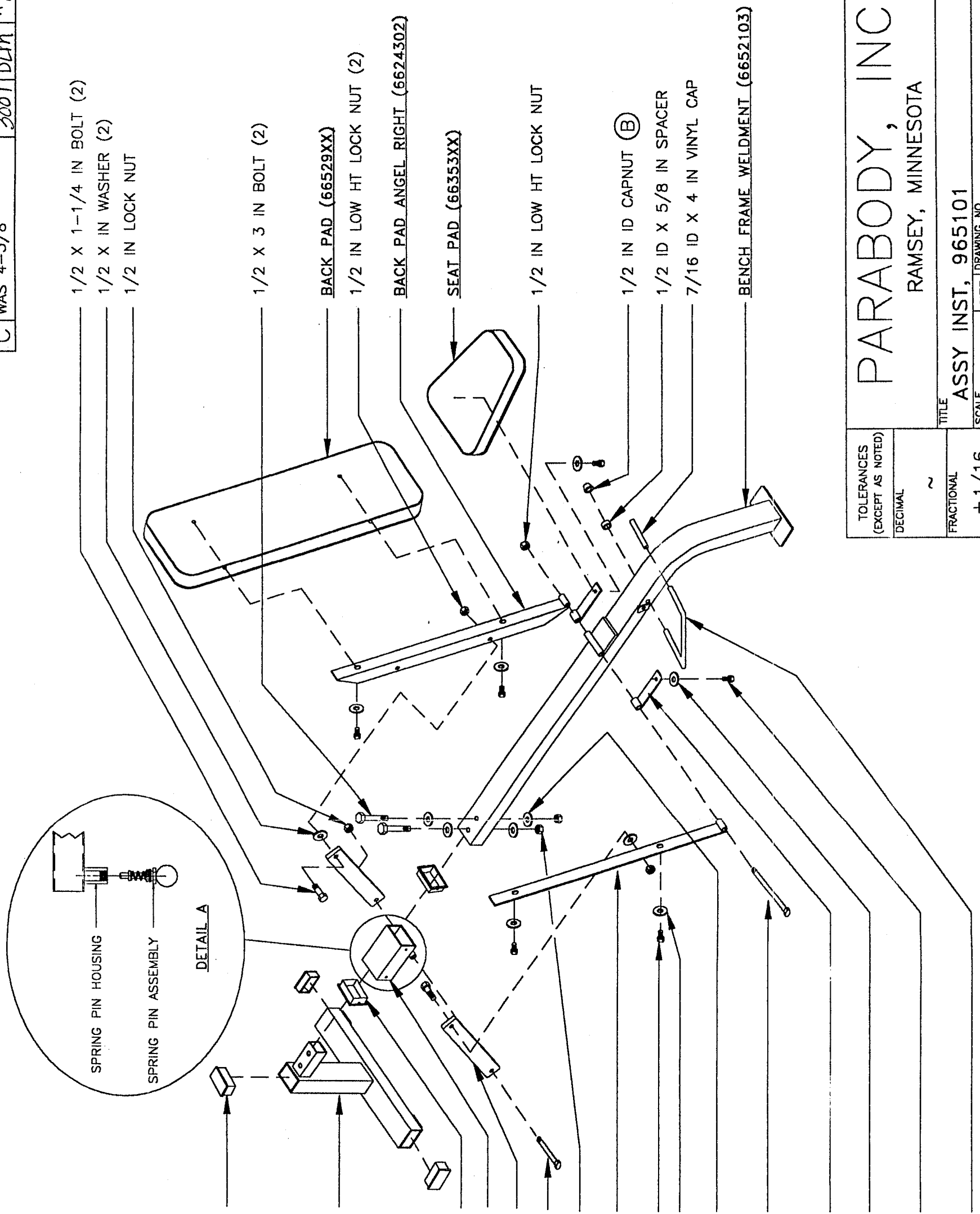

TOLERANCES (EXCEPT AS NOTED)	TITLE	
DECIMAL	~	
FRACTIONAL	± 1/16	
ANGULAR	± 1°	
	SCALE	DRAWING NO.
	1=12	66535
	SHEET 1 OF 1	B
DR	SAL	CHK'D
	9/96	9/96
	APP'D	MGN
PARABODY, INC.		
RAMSEY, MINNESOTA		
ASSY INST, 965101		

965101 FLAT & INCLINE BENCH ASSEMBLY PARTS LIST

SORT AND COUNT ALL PARTS BEFORE BEGINNING ASSEMBLY

HARDWARE:

ITEM	NAME/DESCRIPTION	QTY
1.	1/2 X 9-1/2 IN BOLT	1
2.	1/2 X 6-1/2 IN BOLT	1
3.	1/2 X 3 IN BOLT	2
4.	1/2 X 1-1/4 IN BOLT	2
5.	3/8 X 1 IN BOLT	6
6.	1/2 IN WASHER	6
7.	3/8 IN WASHER	6
8.	1/2 IN LOCK NUT	3
9.	1/2 IN LOW HEIGHT LOCK NUT	3
10.	HINGE TAB	2
11.	6-1/8 X 3-7/8 IN U-PIN	1
12.	1/2 ID X 5/8 IN SPACER	1
13.	SPRING PIN ASSEMBLY	1
14.	1/2 IN ID CAPNUT	1
15.	3 X 2 IN INSERT GUIDE	2
16.	3 X 2 IN END CAP	3
17.	7/16 ID X 4 IN VINYL CAP	1

WELDMENTS/PARTS:

ITEM	NAME/DESCRIPTION	QTY
1.	REAR UPRIGHT WELDMENT (6651703)	1
2.	BENCH FRAME WELDMENT (6652103)	1
3.	ADJ SLEEVE WELDMENT (6652803)	1
4.	BACK PAD ANGLE WELDMENT LEFT (6624202)	1
5.	BACK PAD ANGLE WELDMENT RIGHT (6624302)	1
6.	1/2 X 2 X 15-1/2 IN PLATE (6651602)	2
7.	SEAT PAD (66535XX)	1
8.	BACK PAD (66529XX)	1

NOTE: BOLT LENGTH IS MEASURED FROM THE UNDERSIDE OF THE HEAD OF THE BOLT.

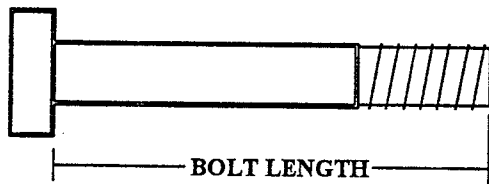

BOLT LENGTH RULER:

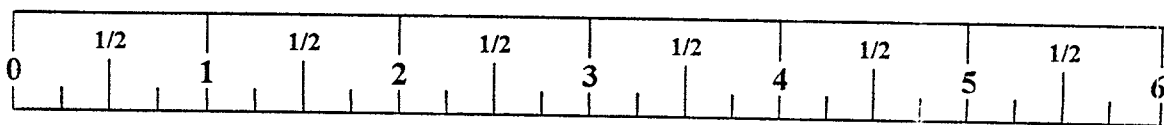

965101 FLAT & INCLINE BENCH ASSEMBLY INSTRUCTIONS

THANK YOU

FOR PURCHASING THE *965101 FLAT & INCLINE BENCH*. PLEASE SAVE THESE ASSEMBLY INSTRUCTIONS FOR YOUR PERSONAL REFERENCE, AND ADDITIONAL SERVICE INFORMATION.

IMPORTANT

- THE *965101 FLAT & INCLINE BENCH* MUST BE ASSEMBLED ON A FLAT, LEVEL SURFACE TO ASSURE ITS PROPER FUNCTION.
- IF YOU EXPERIENCE ANY PROBLEM WITH THE ASSEMBLY OF THIS PRODUCT, PLEASE CONTACT YOUR DEALER OR YOUR PARABODY CUSTOMER SERVICE REPRESENTATIVE AT: 1-800-328-9714.
- **TOOLS REQUIRED:** PATCHET, 3/4 SOCKET and WRENCH, 9/16 SOCKET and WRENCH, and RUBBER Mallet or HAMMER.

1. Slide one (1) 7/16 ID X 4 IN VINYL CAP onto the 6-1/8 X 3-7/8 IN U-PIN and proceed to assemble it to the **BENCH FRAME WELDMENT** as shown on drawing.
2. Insert two (2) 3 X 2 INSERT GUIDES into each end of the **ADJ SLEEVE WELDMENT** as shown on drawing. (NOTE: **MAKE SURE THE INSERT GUIDES SNAP INTO THE HOLES OF THE WELDMENT**). **SECURELY** assemble the **SPRING PIN ASSEMBLY** to the **ADJ SLEEVE WELDMENT** as shown in (DETAIL A).
3. Pull back the **SPRING PIN** on the **ADJ SLEEVE WELDMENT** and slide it over the end of the **BENCH FRAME WELDMENT** as shown on drawing. Slide **WELDMENT** up to the first adjustment hole underneath.
4. Insert three (3) 3 X 2 IN END CAPS into the ends of the **REAR UPRIGHT WELDMENT** as shown on drawing.
5. **SECURELY** assemble the **REAR UPRIGHT WELDMENT** to the **BENCH FRAME WELDMENT** as shown on drawing.
6. Assemble the **LEFT** and **RIGHT BACK PAD ANGLE WELDMENTS**, along with two (2) **HINGE TABS** to the **BENCH FRAME WELDMENT** as shown on drawing. (NOTE: **TIGHTEN CONNECTION ENOUGH TO REMOVE THE PLAY YET ALLOWING THE PARTS TO ROTATE FREELY**).
7. Assemble two (2) 1/2 X 2 X 15-1/2 IN **PLATES** to the inside of the **LEFT** and **RIGHT BACK PAD ANGLE WELDMENTS** as shown on drawing. (NOTE: **TIGHTEN CONNECTION ENOUGH TO REMOVE THE PLAY YET ALLOWING THE PARTS TO ROTATE FREELY**).
8. Rotate the **LEFT** and **RIGHT BACK PAD ANGLE WELDMENTS** up and assemble the 1/2 X 2 X 15-1/2 IN **PLATES** to the **ADJ SLEEVE WELDMENT** as shown on drawing. (NOTE: **DO NOT OVER TIGHTEN THIS CONNECTION**).

965101 FLAT & INCLINE BENCH ASSEMBLY INSTRUCTIONS

9. **SECURELY** assemble the **BACK PAD** to the **LEFT** and **RIGHT BACK PAD ANGLE WELDMENTS** as shown on drawing.
10. **SECURELY** assemble the **SEAT PAD** to the **HINGE TABS** on the **BENCH FRAME WELDMENT** as shown on drawing.

Part # 6653501

4

Revision: 11/26/96

DASH NO	DESCRIPTION
01	AS SHOWN

REVISIONS				
REV	DESCRIPTION	CHG NO	APP'D	DATE
C	WAS 4-3/8	3001	DLM	11/96

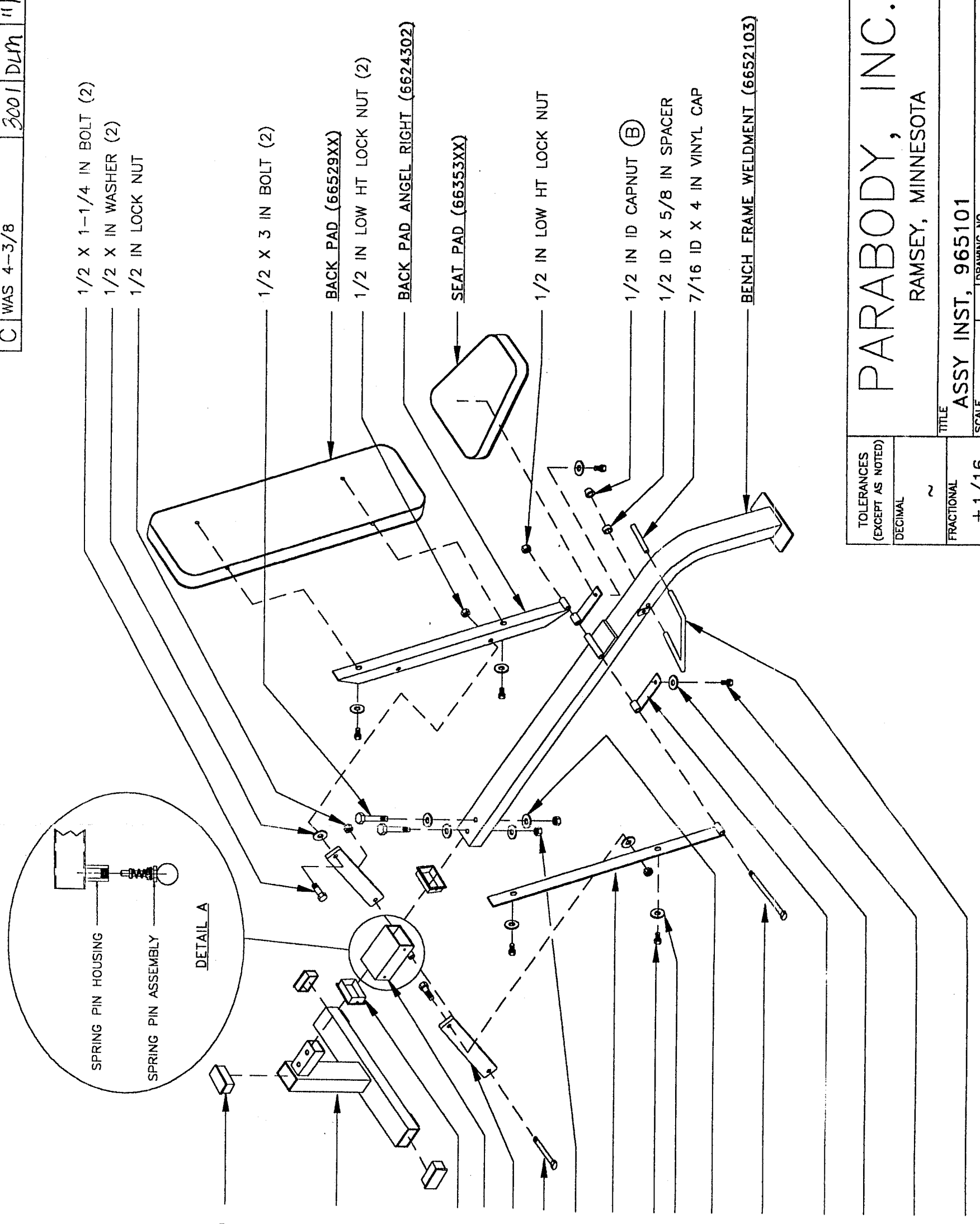

1/2 X 1-1/4 IN BOLT (2)
 1/2 X IN WASHER (2)
 1/2 IN LOCK NUT

1/2 X 3 IN BOLT (2)

BACK PAD (66529XX)
 1/2 IN LOW HT LOCK NUT (2)

BACK PAD ANGLE RIGHT (6624302)

SEAT PAD (66353XX)

1/2 IN LOW HT LOCK NUT

1/2 IN ID CAPNUT (B)

1/2 ID X 5/8 IN SPACER

7/16 ID X 4 IN VINYL CAP

BENCH FRAME WELDMENT (6652103)

3 X 2 END CAP (3)

REAR UPRIGHT WELDMENT (6651703)

3 X 2 IN INSERT GUIDE (2)

ADJ SLEEVE WELDMENT (6652803)

1/2 X 2 X 15-1/2 IN PLATE (6651602)

1/2 X 6-1/2 IN BOLT

1/2 IN LOCK NUT (2)

BACK PAD ANGLE WELDMENT LEFT (6624202)

3/8 X 1 IN BOLT (4)

3/8 IN WASHER (4)

1/2 IN WASHER (4)

1/2 X 9-1/2 IN BOLT

HINGE TAB (2)

3/8 IN WASHER (2)

3/8 X 1 IN BOLT (2)

© 6-1/8 X 3-7/8 U PIN

TOLERANCES (EXCEPT AS NOTED)	
DECIMAL	~
FRACTIONAL	± 1/16
ANGULAR	± 1°

PARABODY, INC. RAMSEY, MINNESOTA	
TITLE ASSY INST, 965101	
SCALE 1=12	SIZE DRAWING NO.
SHEET 1 OF 1	B
DR	SAL
CHK'D	9/96
APP'D	MGN
	9/96
66535	

Free Manuals Download Website

<http://myh66.com>

<http://usermanuals.us>

<http://www.somanuals.com>

<http://www.4manuals.cc>

<http://www.manual-lib.com>

<http://www.404manual.com>

<http://www.luxmanual.com>

<http://aubethermostatmanual.com>

Golf course search by state

<http://golfingnear.com>

Email search by domain

<http://emailbydomain.com>

Auto manuals search

<http://auto.somanuals.com>

TV manuals search

<http://tv.somanuals.com>