

LIFE FITNESS

CLUB SERIES LAT PULLDOWN

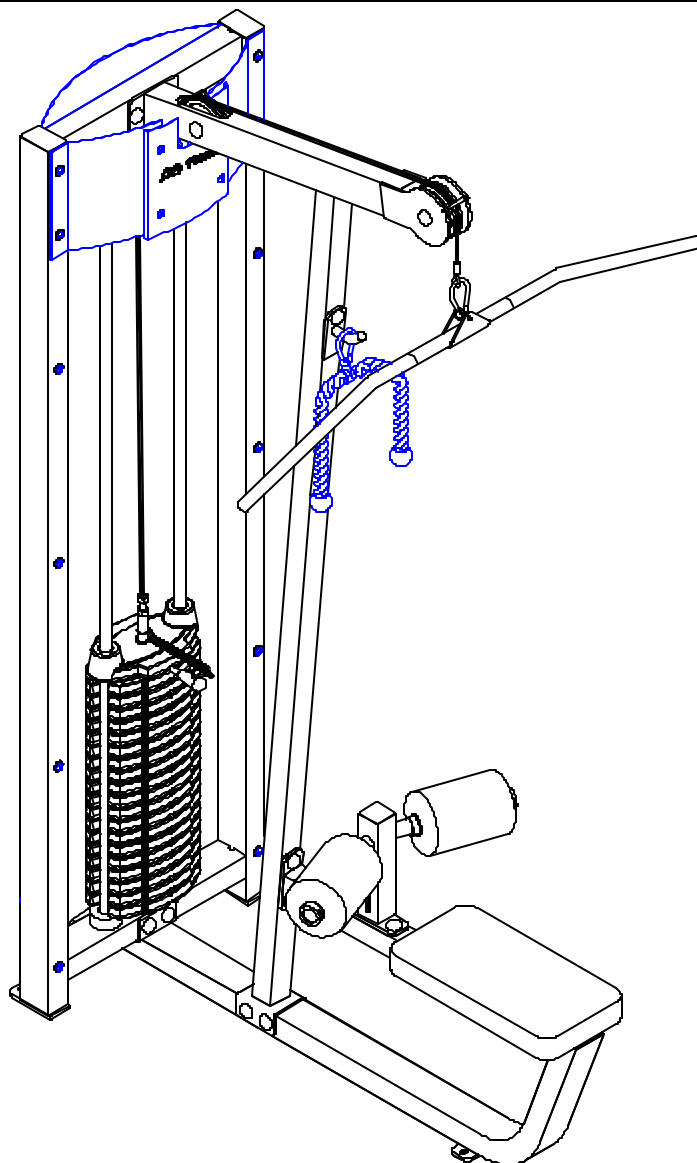

ASSEMBLY INSTRUCTIONS

PARTS LIST

KEY	PART #	DESCRIPTION	QTY
1	69046xx	ASSY TOWER	1
1A	6920001	CABLE	1
1B	6714901	GUIDE ROD BUSHINGS	2
2	69032xx	WLDMT, MAIN UPRIGHT	1
2A	6692601	3 X 2 END CAP	1
2B	6902201	SUPPORT HOOK CHROME	1
2C	3222801	4.5" PULLEY	3
2D	3102933	3/8-16 X 2 BOLT	1
2E	3102903	3/8-16 X 2.5 BOLT	1
2F	3102922	3/8-16 X 2.75 BOLT	1
2G	6866701	3/8 RH WASHER	8
2H	6866601	CAP RH 20 BLK	8
2I	3102807	3/8-16 NYLOCK NUT LOW HT	4
2J	3102514	3/8 FLAT WASHER	6
2K	6480301	3/8 SPACER	2
2L	6827001	CABLE CLIP	1
2M	3102904	3/8-16 X 3 BOLT	1
2N	6422702	3/8 SPACER	2
3	69047xx	ASSY BENCH FRAME	1
4	6907002	ASSY LAT BAR	1
4A	3103107	RUBBER GRIP	2
5	6901402	KNEE SUPPORT BLK	1
5A	6928101	ROLLER PAD	2
5B	6405201	2 SQ END CAP	1
5C	3222701	SHAFT COLLAR	2
5D	3119303	1.25 END CAP	2
6	69010xx	WLDMT, GUIDE ROD SUPPORT	1
7	6851501	TRICEP ROPE	1
8	6923602	HEAD PLATE BLK	1
8A	69279xx	Knee Hold Down	1

KEY	PART #	DESCRIPTION	QTY
9	3102922	3/8 X 2-3/4" BOLT	8
10	3102905	3/8 X 3-3/4" BOLT	4
11	3102807	3/8" LOW HEIGHT LOCK NUT	10
12	6957001	WEIGHT STACK LABEL	1
13	3102514	3/8" SAE WASHER	8
14	6866701	3/8" RH WASHER	22
15	6943801	WEIGHT STACK SELECTOR PIN	1
16	3108001	WEIGHT STACK CUSHION	2
17	6866601	BLACK RH CAP	2
18	68775xx	SEAT PAD	1
19	3222001	1" SHAFT COLLAR	2
20	6714901	GUIDE ROD BUSHING	2
21	3103801	SNAP LINK	1
22	6941601	PLACARD LABEL	1
23	6941701	LANGUAGE PLACARD LABEL	1
24	6887202	10 LB. WEIGHT PLATE (STD)	20
25	6888402	15 LB. WEIGHT PLATE (OPT)	10
26	6926801	GUIDE ROD	2
27	6866602	RH CAP WHITE	20
OR	6866603	RH CAP PLATINUM	20
27S	3221601	STARLOCK WASHER	12
28	3202405	3/8 X 3-1/2" BUTTON HEAD BOLT	12
29	6921207	FRONT PARTIAL SHROUD	1
30	6861502	REAR PARTIAL SHROUD	1
31	6914602	FULL FRONT SHROUD	1
32	6924802	FULL REAR SHROUD	1
33	6957001	WEIGHT STACK LABEL	1
34	6957101	HEAVY WEIGHT STACK LABEL	1

*For all 5 digit part numbers you need to add the color at the end.
For shrouds and weldments please use the following codes:

xxxxx07 Denotes Platinum
xxxxx08 Denotes White

**Language placard kit comes with Dutch, French, German, Portuguese, Spanish, Japanese, and Italian.

*For upholstery, please use the following codes:

#02 ROYAL BLUE
#03 SLATE
#04 CRANBERRY
#05 NORTHWOODS
#06 SPACE BLUE
#07 AMERICAN BEAUTY RED
#08 SUEDE
#12 BLACK
#13 HUNTER GREEN
#14 REGIMENTAL BLUE
#15 GINGERSNAP
#16 CONCORD
#17 URQUOISE
#18 RASPBERRY
#19 CROCUS

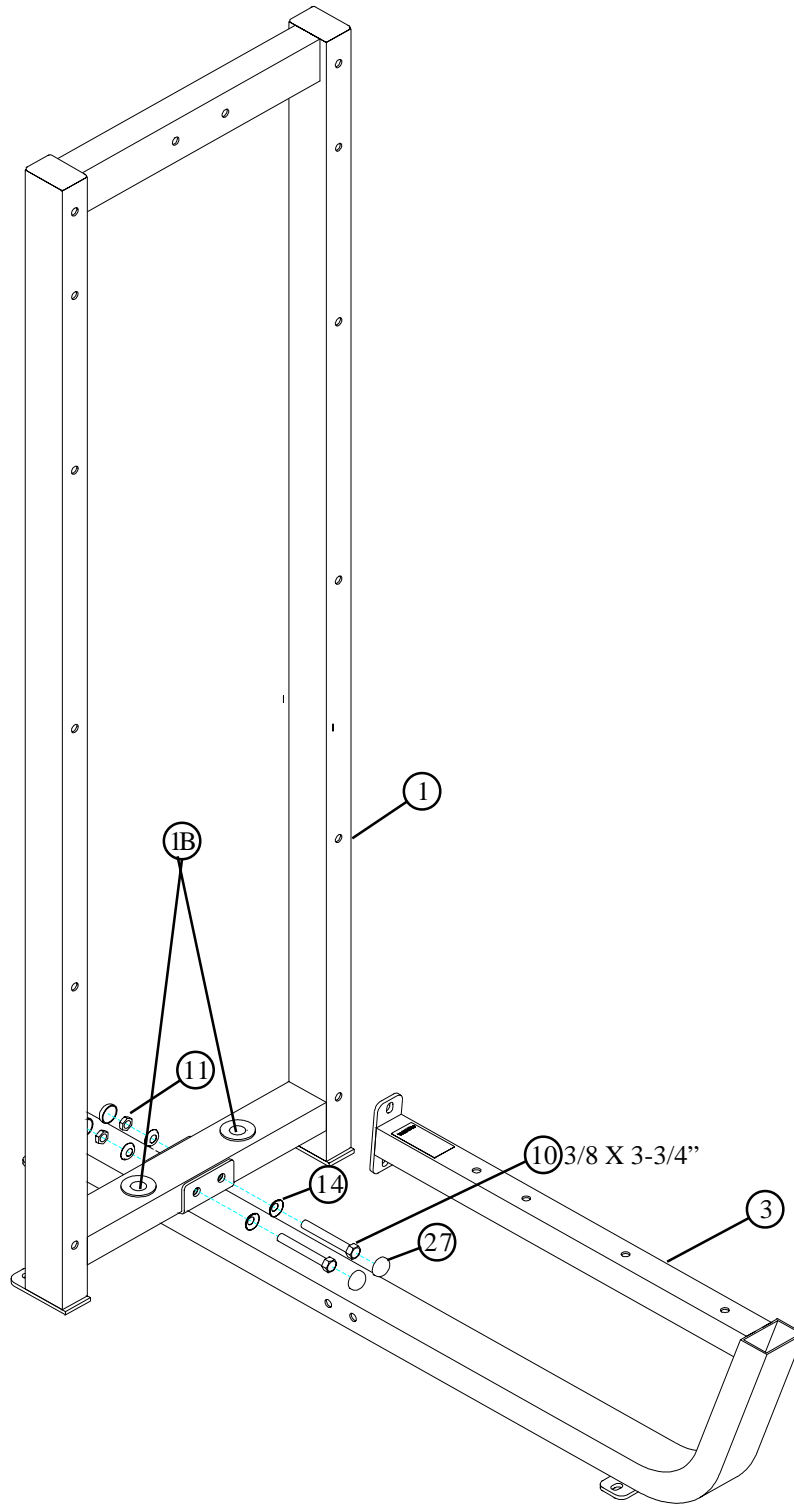
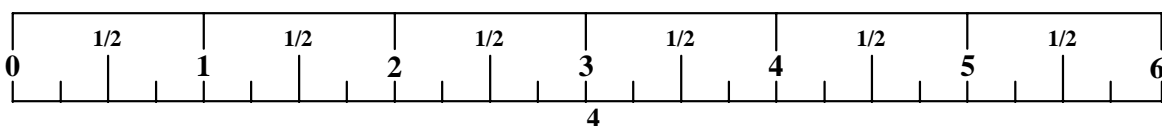
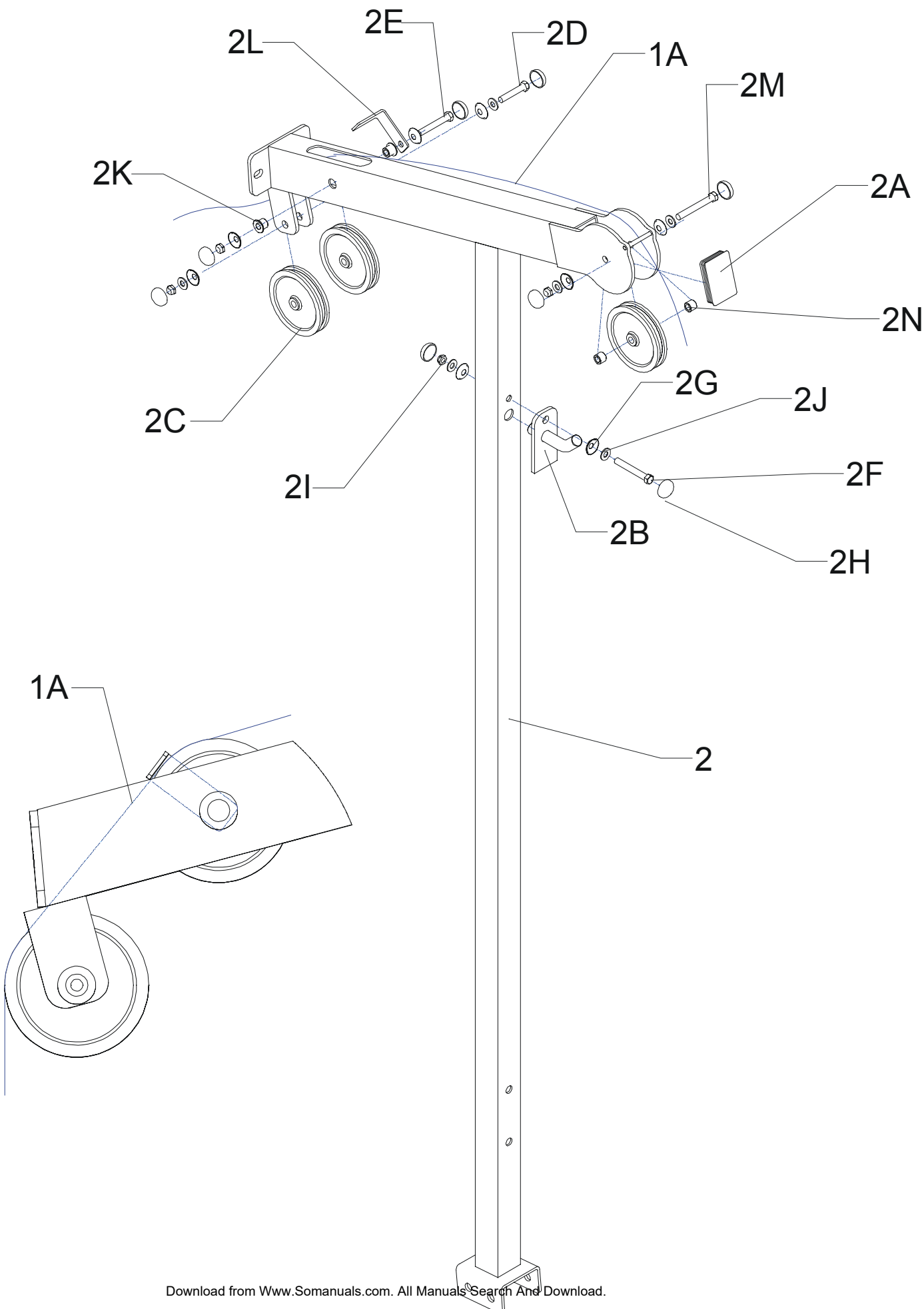

FIGURE 1

STEP 1:

- **LOOSELY** assemble the TOWER (1) to the BENCH FRAME (3) using four RH CAPS (27), two 3/8 X 3-3/4" BOLTS (10), four 3/8" RH WASHERS (14) and two 3/8" LOW HEIGHT LOCK NUTS (11) as shown in FIGURE 1.





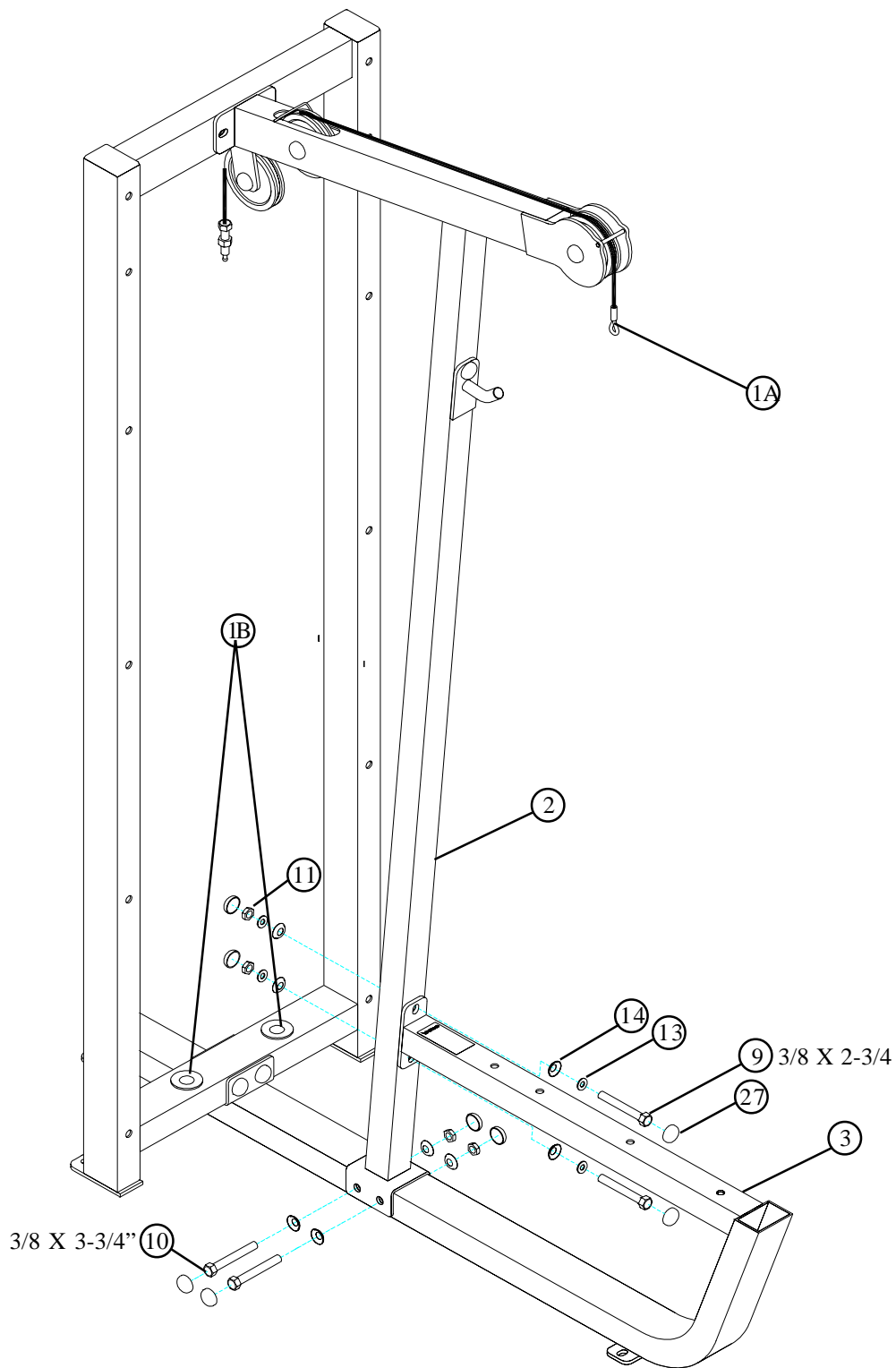
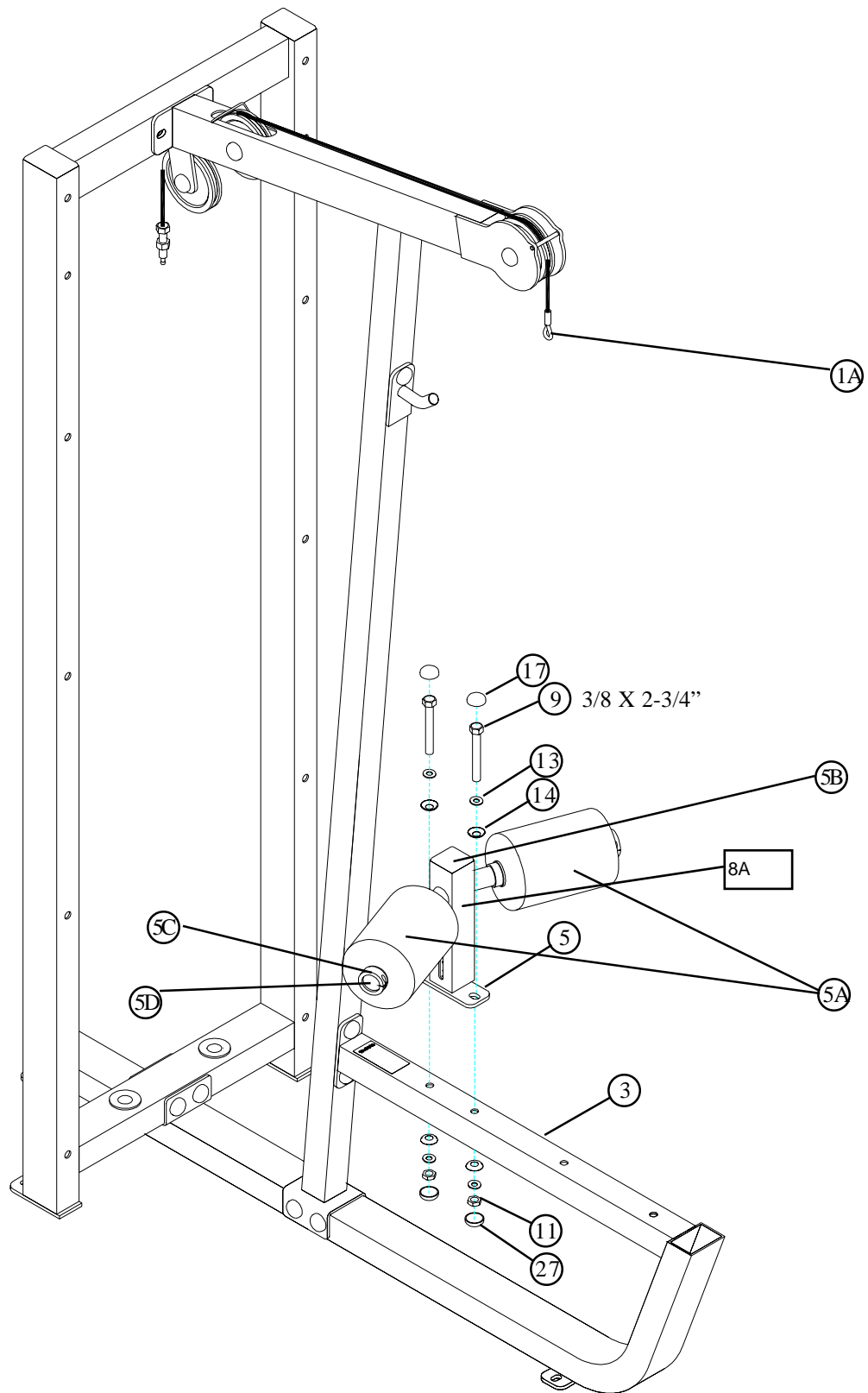

FIGURE 2

STEP 2:

- **LOOSELY** assemble the MAIN UPRIGHT (2) to the base of the BENCH FRAME (3) using four RH CAPS (27), two 3/8 X 3-3/4" BOLTS (10), four 3/8" RH WASHERS (14) and two 3/8" LOW HEIGHT LOCK NUTS (11) as shown in FIGURE 2.
- **LOOSELY** assemble the MAIN UPRIGHT (2) to the top tube of the BENCH FRAME (3) using four RH CAPS (27), two 3/8 X 2-3/4" BOLTS (9), four 3/8" SAE WASHERS (13), four 3/8" RH WASHERS (14) and two 3/8" LOW HEIGHT LOCK NUTS (11) as shown in FIGURE 2.
- **Securely tighten all loose frame connections made to this point, then proceed to snap RH CAPS (27) over the RH WASHERS (14) on all tightened connections.**

FIGURE 3



STEP 3:

- **SECURELY** assemble the KNEE SUPPORT (5) to the BENCH FRAME (3) using two BLACK RH CAPS (17), two RH CAPS (27), two 3/8 X 2-3/4" BOLTS (9), four 3/8" SAE WASHERS (13), four 3/8" RH WASHERS (14) and two 3/8" LOW HEIGHT LOCK NUTS (11) as shown in FIGURE 3.

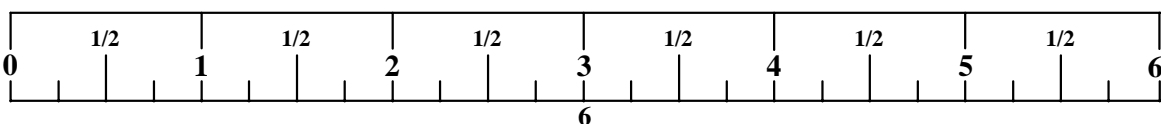

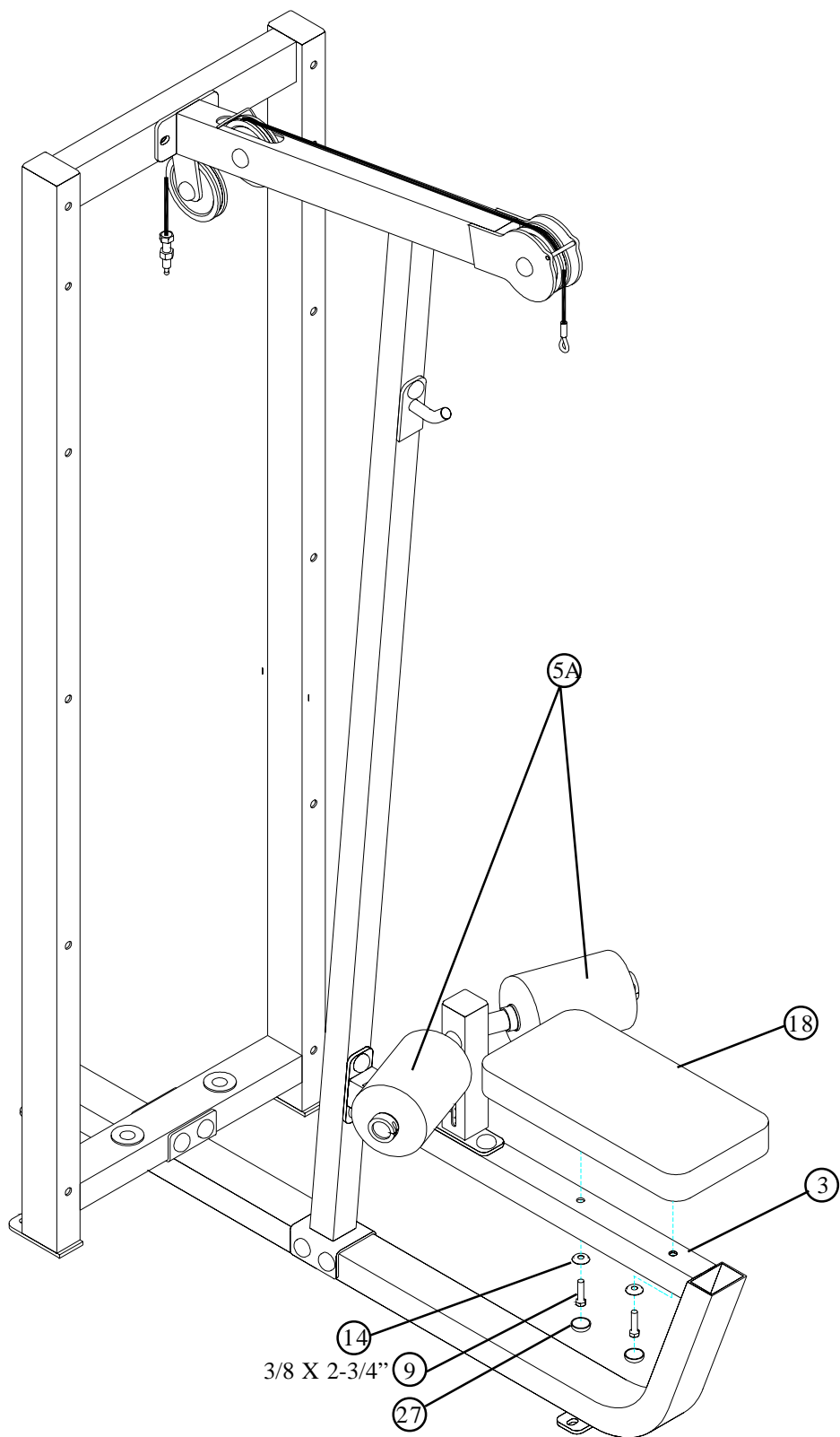
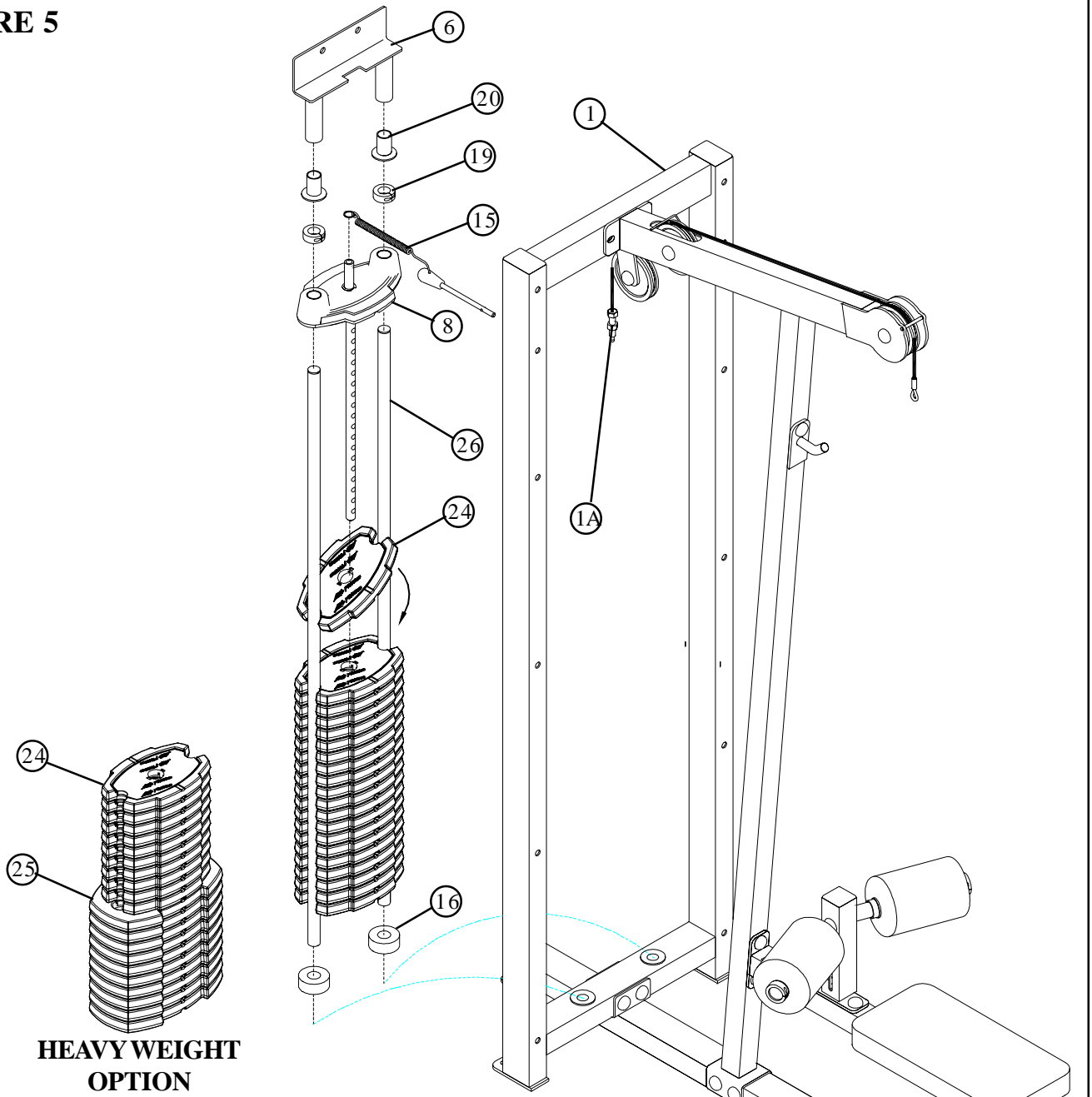

FIGURE 4

STEP 4

- **SECURELY** assemble the SEAT PAD (18) to the BENCH FRAME (3) using two RH CAPS (27), two 3/8 X 2-3/4" BOLTS (9) and two 3/8" RH WASHERS (14) as shown in FIGURE 4.

FIGURE 5



STEP 5:

- Insert the two GUIDE RODS (26) (found in the SHROUD KIT) into the base of the TOWER (1) as shown in FIGURE 5. Lubricate the GUIDE RODS (26) with a silicon or teflon spray that is available at most hardware stores.
- Slide two WEIGHT STACK CUSHIONS (16) down over the GUIDE RODS (26). See FIGURE 5.
- Using **EXTREME CARE** place twenty 10 LB. WEIGHT PLATES (24) over the GUIDE RODS (26) as shown in FIGURE 5. **(NOTE: If HEAVY WEIGHT OPTION is being used, slide ten 15LB. WEIGHT PLATES (25) over the GUIDE RODS (26) first, then slide ten 10 LB. WEIGHT PLATES (24) over the GUIDE RODS.)**
- Carefully Slide the HEAD PLATE (8) down over the GUIDE RODS (26) onto the weight stack as shown in FIGURE 5.
- Slide one WEIGHT STACK SELECTOR PIN (15) over the shaft on the HEAD PLATE (8) as shown in FIGURE 5.
- Slide two 1" SHAFT COLLARS (19) over each GUIDE ROD (26) as shown in FIGURE 5.
- Slide two GUIDE ROD BUSHINGS (20) over each GUIDE ROD (26).
- Place the GUIDE ROD SUPPORT (6) over the GUIDE RODS (26) as shown in FIGURE 5.

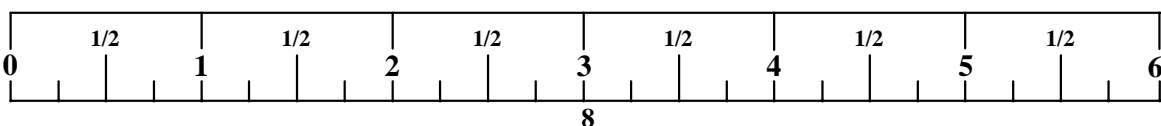
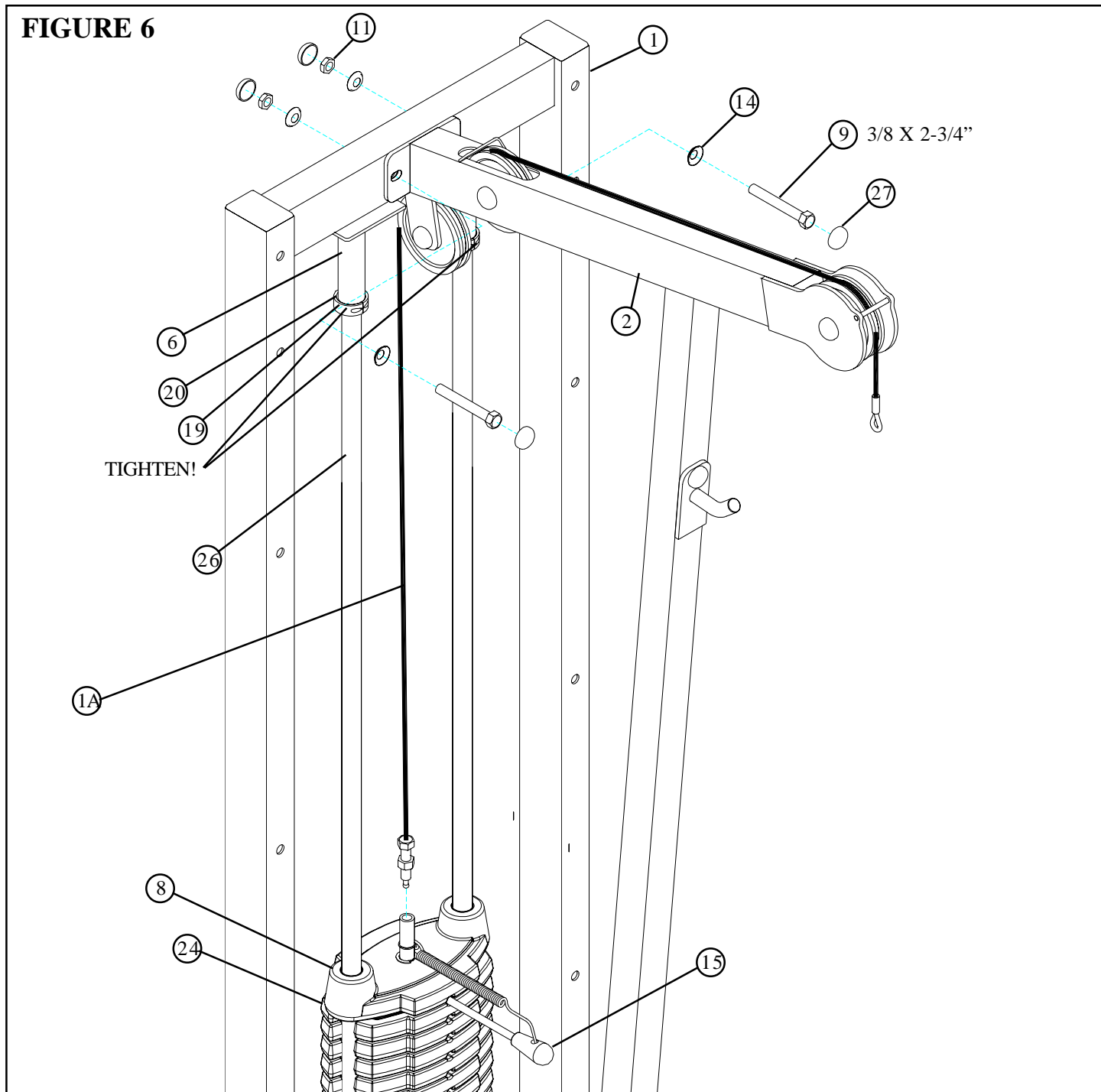

FIGURE 6



STEP 6:

- **SECURELY** assemble the GUIDE ROD SUPPORT (6) to the TOWER (1) and MAIN UPRIGHT (2) using four RH CAPS (27), two 3/8 X 2-3/4" BOLTS (9), four 3/8" RH WASHERS (14) and two 3/8" LOW HEIGHT LOCK NUTS (11) as shown in FIGURE 6.
- Slide GUIDE ROD BUSHINGS (20) into the tubes on the GUIDE ROD SUPPORT (6), slide 1" SHAFT COLLARS (19) underneath the GUIDE ROD BUSHINGS (20) and **SECURELY** tighten the set screws.
- Insert the WEIGHT STACK PIN (15) into the WEIGHT STACK as shown in FIGURE 6.
- Screw the threaded end of the CABLE all way into the end of the shaft on the HEAD PLATE (8) and tighten jam nut securely. See FIGURE 6.

FIGURE 7

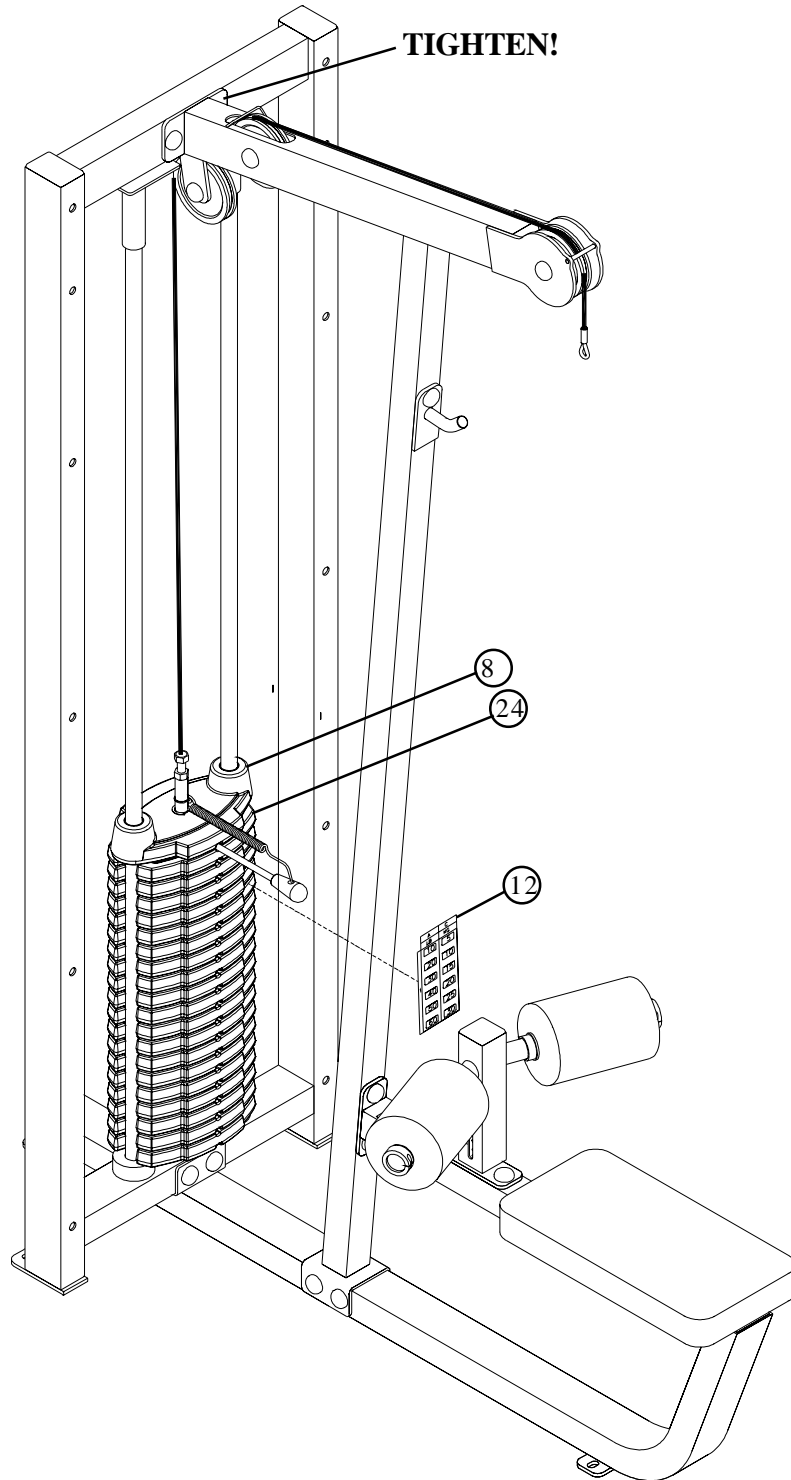

ST*****

- The WEIGHT STACK LABEL sheet (12) includes labels for both lbs. and kgs. for both the standard and optional weight stacks.
- Peel the backing off the WEIGHT STACK LABELS (12), line up sheet to the right of the selector opening and apply labels to the WEIGHT PLATES (24), starting with the HEAD PLATE (8) as shown in FIGURE 7.
- **REFER TO SHROUD KIT ASSEMBLY INSTRUCTIONS.**

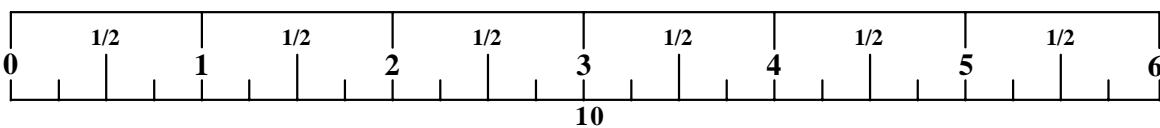

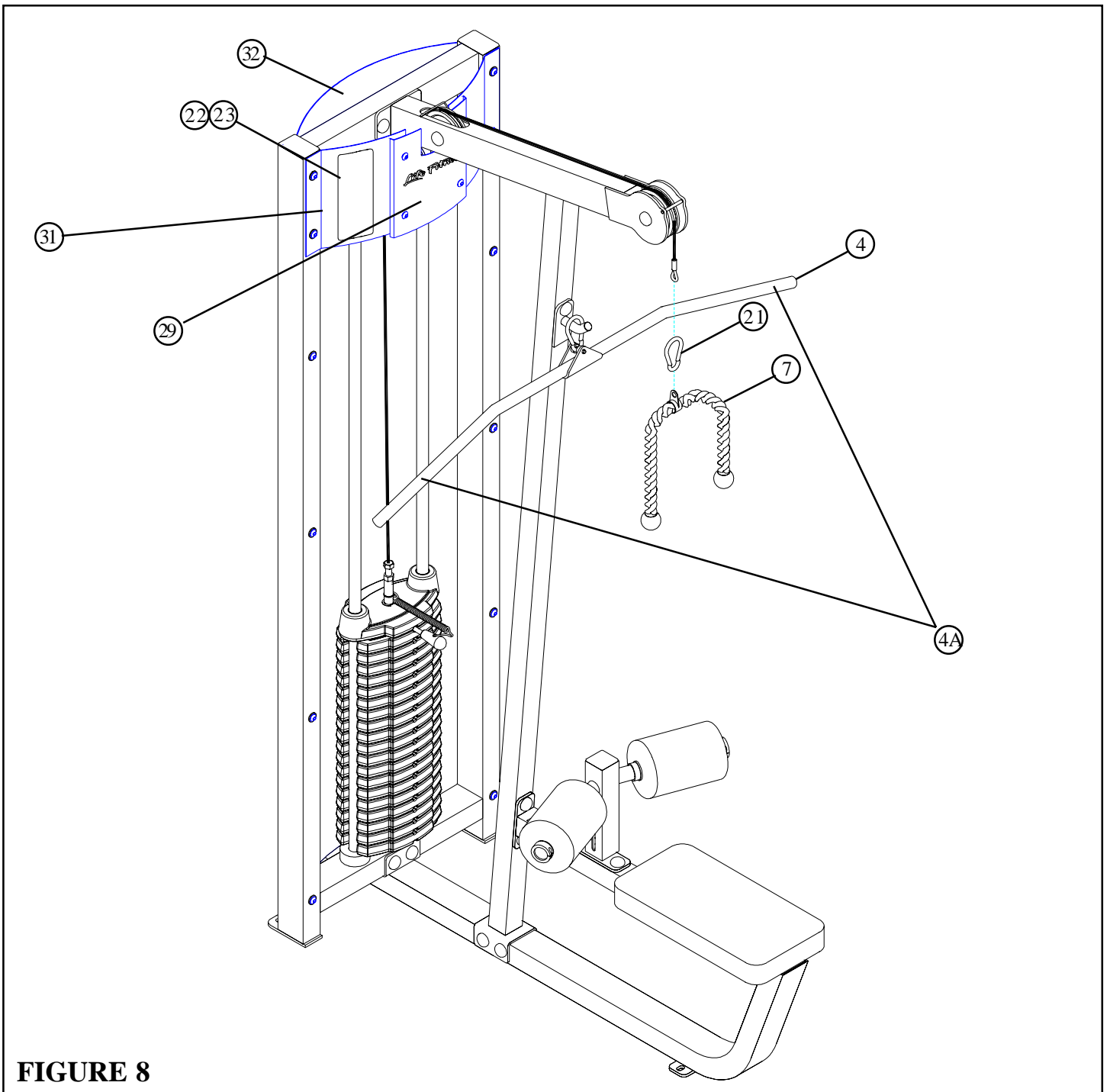

FIGURE 8

STEP 8:

- Assemble the PLACARD LABEL (22) or the FOREIGN LANGUAGE PLACARD LABEL (23) to the FRONT SHROUD as shown in FIGURE 8.
- Attach LAT BAR (4) and/or TRICEP ROPE (7) end of cable using on SNAP LINK (21) with the TRICEP ROPE (7) as shown in FIGURE 8.

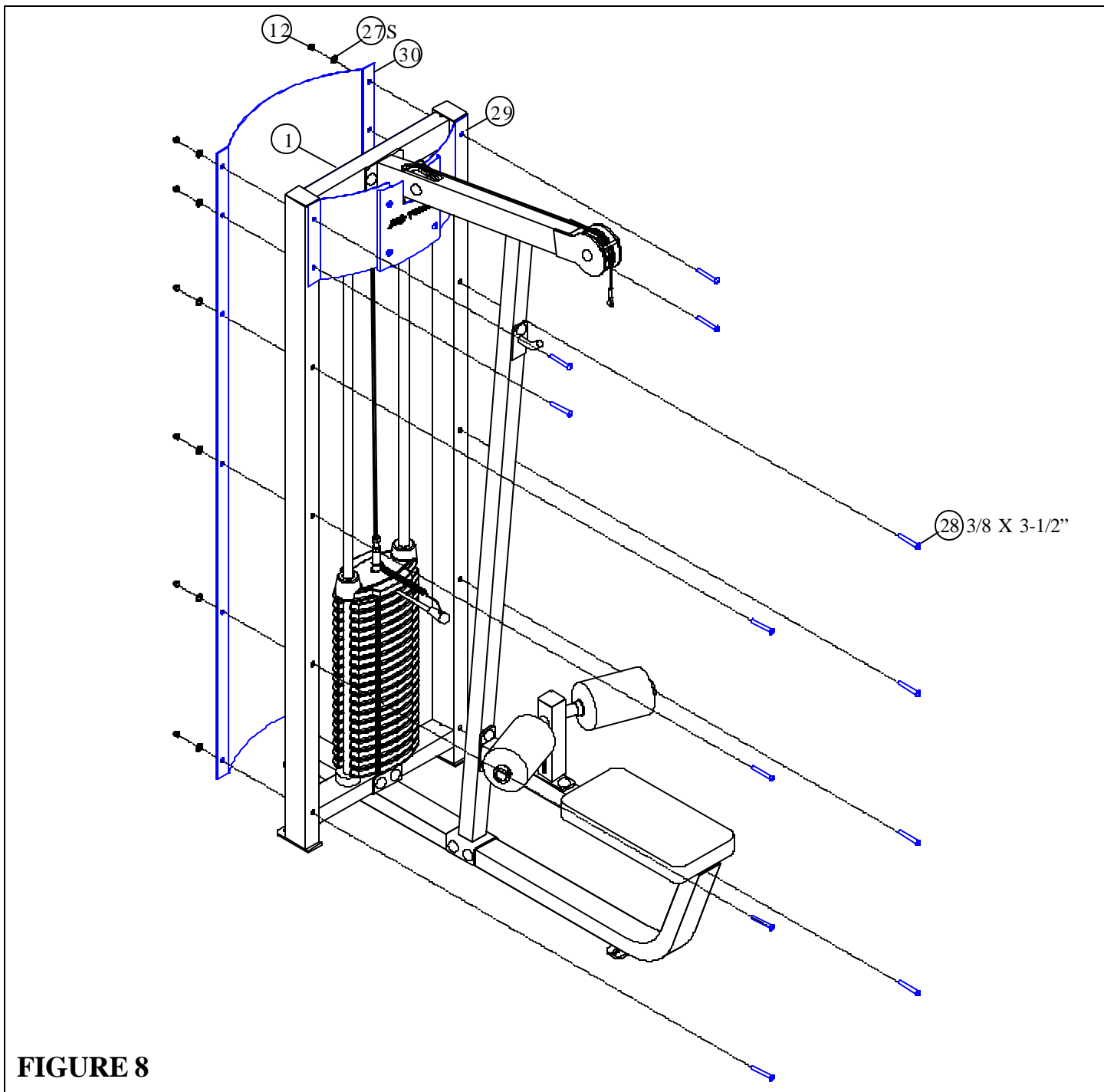

FIGURE 8

STEP 8:

(NOTE: If the PARTIAL SHROUD KIT is being used follow STEP 8. If the FULL SHROUD KIT is being used follow STEP 9.)

- **SECURELY** assemble the FRONT PARTIAL SHROUD (29) and the REAR PARTIAL SHROUD (30) to the TOWER (1) using twelve 3/8 X 3-1/2" BUTTON HEAD BOLTS (28), twelve STARLOCK WASHERS (27), and twelve 3/8" ACORN NUTS (12) as shown in FIGURE 8.

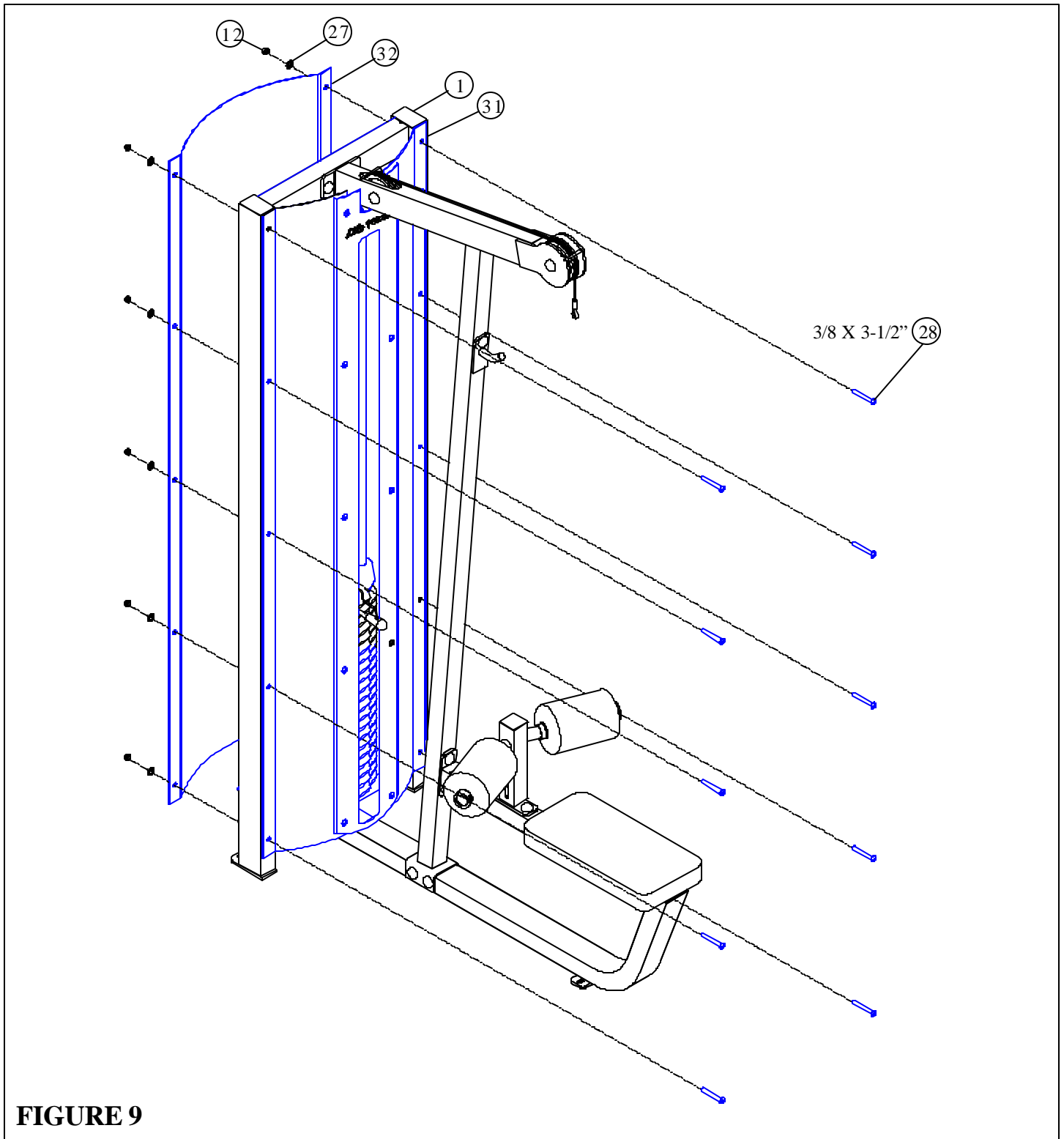
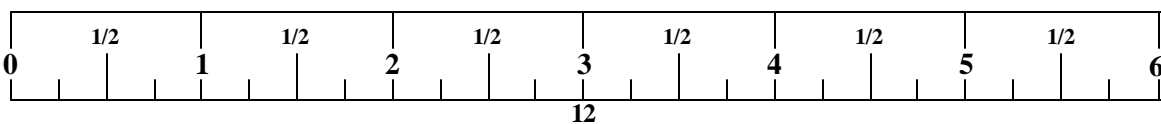

FIGURE 9

STEP 9:

- **SECURELY** assemble the FRONT FULL SHROUD (31) and the REAR FULL SHROUD (32) to the TOWER (1) using ten 3/8 X 3-1/2" BUTTON HEAD BOLTS (28), ten STARLOCK WASHERS (27), and ten 3/8" ACORN NUTS (12) as shown in FIGURE 9.



CAUTION-PLEASE READ

There is a risk assumed by individuals who use this type of equipment. To minimize risk, please follow these rules:

1. Inspect equipment daily. Tighten all loose connections and replace worn parts immediately. Failure to do so may result in serious injury.
2. Do not allow minors or children to play on or around this equipment.
3. Exercise with care to avoid injury.
4. Consult your physician before beginning any exercise program.

WARRANTY INFORMATION

10 YEARS	STRUCTURAL FRAME
3 YEARS	PILLOW BLOCKS, PULLEYS, WEIGHT PLATES AND GUIDE RODS
1 YEAR	CABLES
90 DAYS	UPHOLSTERY

PREVENTATIVE MAINTENANCE TIPS

<i>Action</i>	<i>DAILY</i>	<i>WEEKLY</i>	<i>QUARTERLY</i>	<i>BI-ANNUALLY</i>	<i>AS NEEDED</i>
CLEAN					
Upholstery	X				
Guide Rods					X
Hand Grips					X
INSPECT					
Visual Overall	X				
Cables		X			
Hardware			X		
Frame				X	
Hand Grips					X
LUBRICATE					
Guide Rods					X

Clean:

- Upholstery with mild soap and water.
- Guide rods with a cotton cloth.
- Hand grips with mild soap and water.
- Frame damage can be repaired with touch-up paint can be purchased from your LifeFitness customer service representative at (800)328-9714.

Inspect:

- Cables for wear or damage and proper tension (should not exceed 3/4" deflection.) Pay close attention at bends and attachment points.
- Hardware should be checked for looseness. Tighten as required.
- Frames should be inspected for wear or damage.
- Hand Grips should be checked for wear or damage

Lubricate:

- Lube the Guide Rods. Apply the lubricant to a cotton cloth, then run the cotton cloth up and down the guide rods as needed. Do not spray lubricant directly on the Guide Rods.

Thank you for purchasing the LifeFitness CLUB SERIES LAT PULLDOWN. If unsure of proper use of equipment, call your local LifeFitness distributor or call the LifeFitness customer service department at (800) 328-9714.

Free Manuals Download Website

<http://myh66.com>

<http://usermanuals.us>

<http://www.somanuals.com>

<http://www.4manuals.cc>

<http://www.manual-lib.com>

<http://www.404manual.com>

<http://www.luxmanual.com>

<http://aubethermostatmanual.com>

Golf course search by state

<http://golfingnear.com>

Email search by domain

<http://emailbydomain.com>

Auto manuals search

<http://auto.somanuals.com>

TV manuals search

<http://tv.somanuals.com>