

Chest Press

Assembly Instructions



LifeFitness

Chest Press

Assembly Instructions

Item	Qty	Description	Part Number
1	1	Front Brace	80113XX
2	1	Rear Brace	80114XX
3	1	Tower	79854XX
4	4	M10 x 130mm Bolt	3251720
5	42	3/8" Flat Washer	3102514
6	13	M10 Nylock Nut	3242002
7	1	Seat Frame	80111XX
8	6	M10 x 90mm Bolt	3251715
9	1	Top Brace	80115XX
10	2	M10 x 70mm Bolt	3251711
11	1	Pivot Shaft	7316508
12	1	Long Spacer	7330007
13	2	Bearing	3235601
14	2	Small Spacer	7330001
15	1	Workarm	80112XX
16	5	M10 x 25mm Bolt	3251702
17	1	Output Cam	7998501
18	1	Output Plate	7998495
19	1	Output Ring	7998895
20	6	M10 x 45mm Bolt	3251706
21	1	Rear Shroud	8024803

Item	Qty	Description	Part Number
22	1	Front Shroud	8024703
23	4	M10 x 20mm Bolt	3251701
24	1	Plate	7322301
25	1	Cam Guard	8013201
26	2	M5 x 10mm Phillips Screw	3239101
27	1	Seat Pad	72972XX
28	1	Back Pad	74741XX
29	2	M10 x 35mm Bolt	3251704
30	1	M10 Hex Jam Nut	3236901
31	1	Cable	7979701
32	1	Rod End Bearing	3237901
33	1	M10 x 40mm Bolt	3251705
34	1	Spacer	7489402
35	1	Cable Retaining Plate	8001801
36	1	Output Cam Cover Plate	7998995
37	2	M8 Hex Jam Nut	3247502
38	2	Foot Leveler Shim	7893101
39	3	7/16" Hole Plug	3237401
40	4	1" Hole Plug	3237403
41	1	Multi-Language Label	8047101

Tools Required:

- 17mm Wrench
- Metric Allen Wrench Set
- Ratchet with 17mm Socket
- Rubber Mallet
- Ratchet Extension
- Phillips Screwdriver

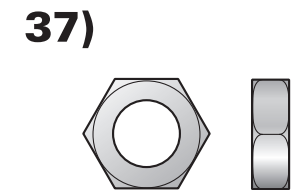
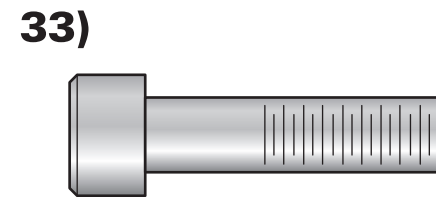
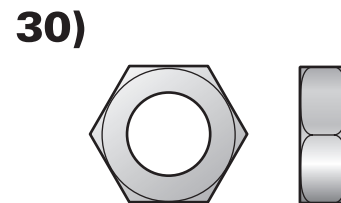
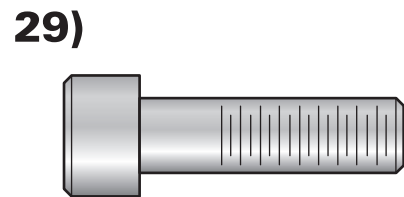
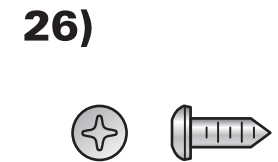
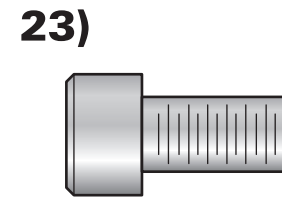
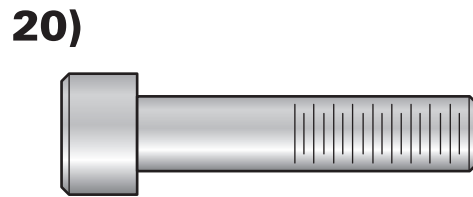
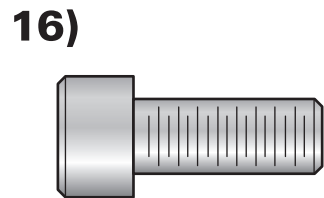
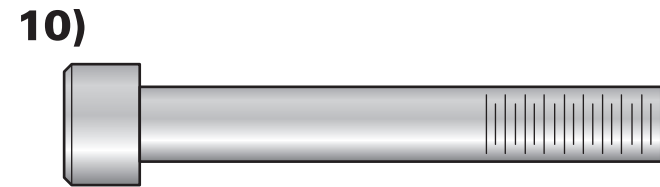
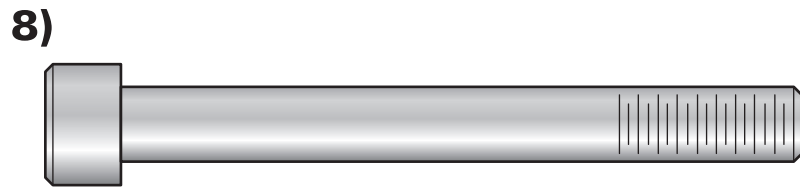
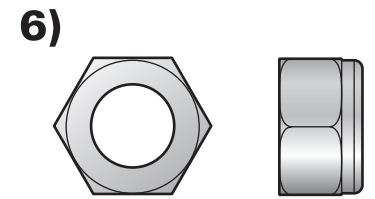
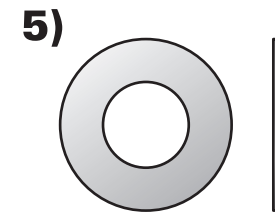

Chest Press

Assembly Instructions

1. LOOSELY assemble the FRONT BRACE (1) and REAR BRACE (2) to the TOWER (3) using four M10 X 130mm BOLTS (4), eight 3/8" SAE WASHERS (5) and four M10 NYLOCK NUTS (6) as shown.
2. LOOSELY assemble the SEAT FRAME (7) to the FRONT BRACE (1) and REAR BRACE (2) using four M10 X 90mm BOLTS (8), eight 3/8" SAE WASHERS (5) and four M10 NYLOCK NUTS (6) as shown.
3. LOOSELY assemble the TOP BRACE (9) to the SEAT FRAME (7) and TOWER (3) using two M10 X 90mm BOLTS (8), four 3/8" SAE WASHERS (5) and two M10 NYLOCK NUTS (6) at the SEAT FRAME and two M10 X 70mm BOLTS (10), four 3/8" SAE WASHERS (5) and two M10 NYLOCK NUTS (6) at the TOWER as shown.
4. Tighten all BOLTS and NUTS securely.

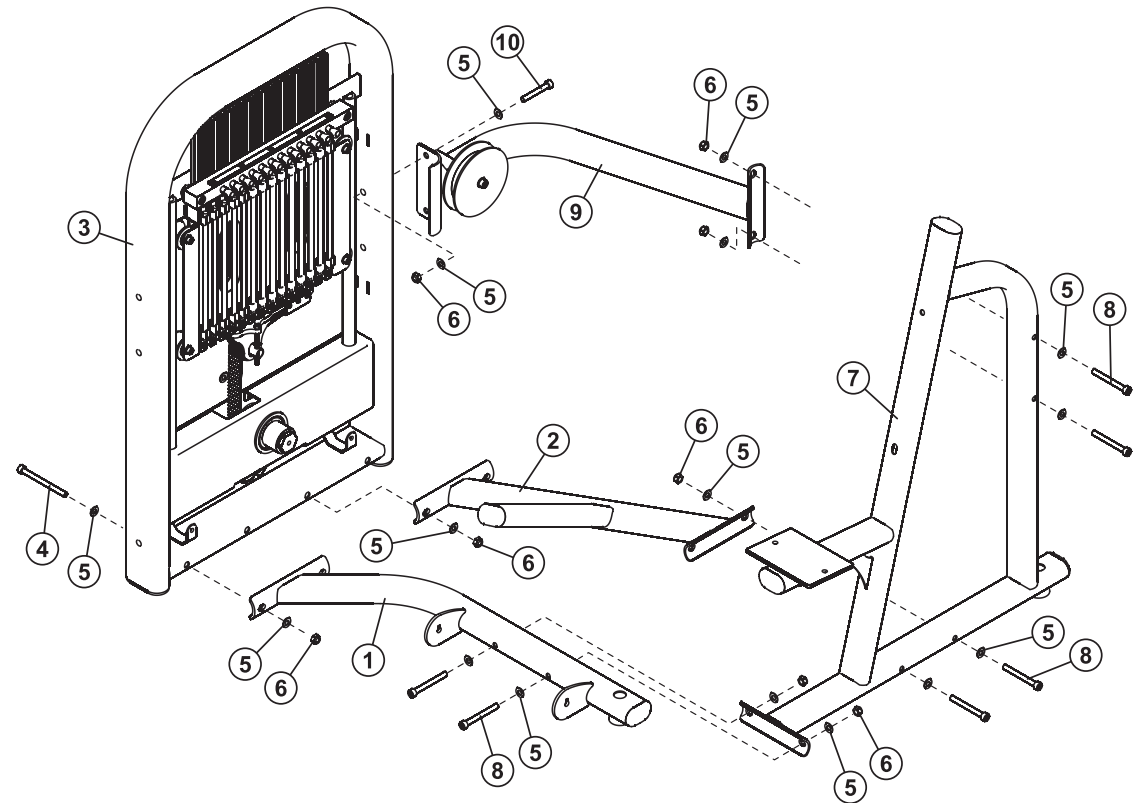

5. Insert the PIVOT SHAFT (11), LONG SPACER (12), two BEARINGS (13) and two SMALL SPACER (14) into the WORKARM (15) as shown. Carefully insert the WORKARM into the FRONT BRACE (1) and secure it with two M10 X 25mm BOLTS (16) and two 3/8" SAE WASHERS (5). Tighten the BOLTS securely.

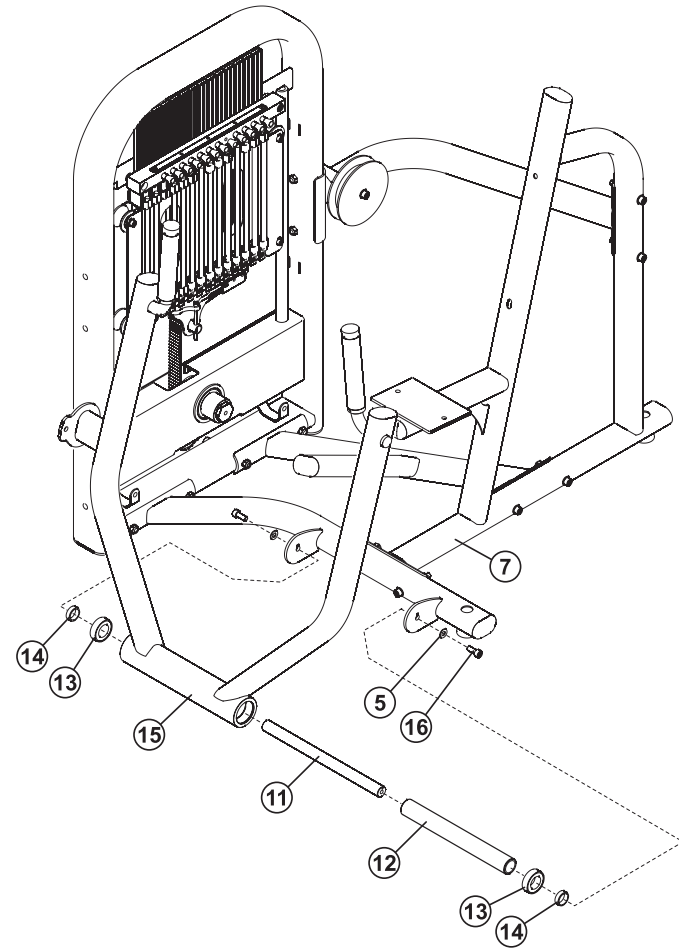

LifeFitness

Chest Press

Assembly Instructions

6. Assemble the OUTPUT CAM (17), OUTPUT PLATE (18), and OUTPUT RING (19) using three M10 X 45mm BOLTS (20) and three 3/8" SAE WASHERS (5) as shown. Tighten the BOLTS securely.

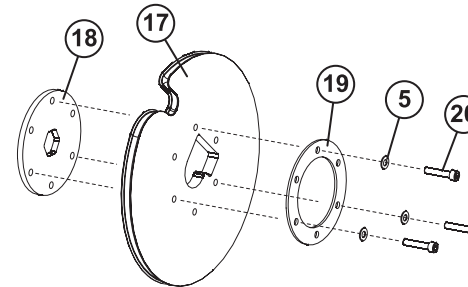

7. Assemble the REAR SHROUD (21) and FRONT SHROUD (22) to the TOWER (3) using four M10 X 20mm BOLTS (23), four 3/8" SAE WASHERS (5) as shown. Be sure all tabs along the sides and top of the SHROUDS are fully engaged in the slots located inside the TOWER. Tighten the BOLTS securely. Do not overtighten the BOLTS.
8. Secure the OUTPUT CAM ASSEMBLY (A) to the TOWER HUB (B) using one M10 X 25mm BOLTS (16), one 3/8" SAE WASHERS (5) and one PLATE (24) as shown. Tighten the BOLT securely.

IMPORTANT: Be sure the OUTPUT CAM ASSEMBLY is oriented as shown before securing it to the TOWER HUB.

9. Attach the CAM GUARD (25) to the FRONT SHROUD (22) using two M5 X 10mm PHILLIPS SCREWS (26). Tighten the SCREWS securely. Do not overtighten the SCREWS.

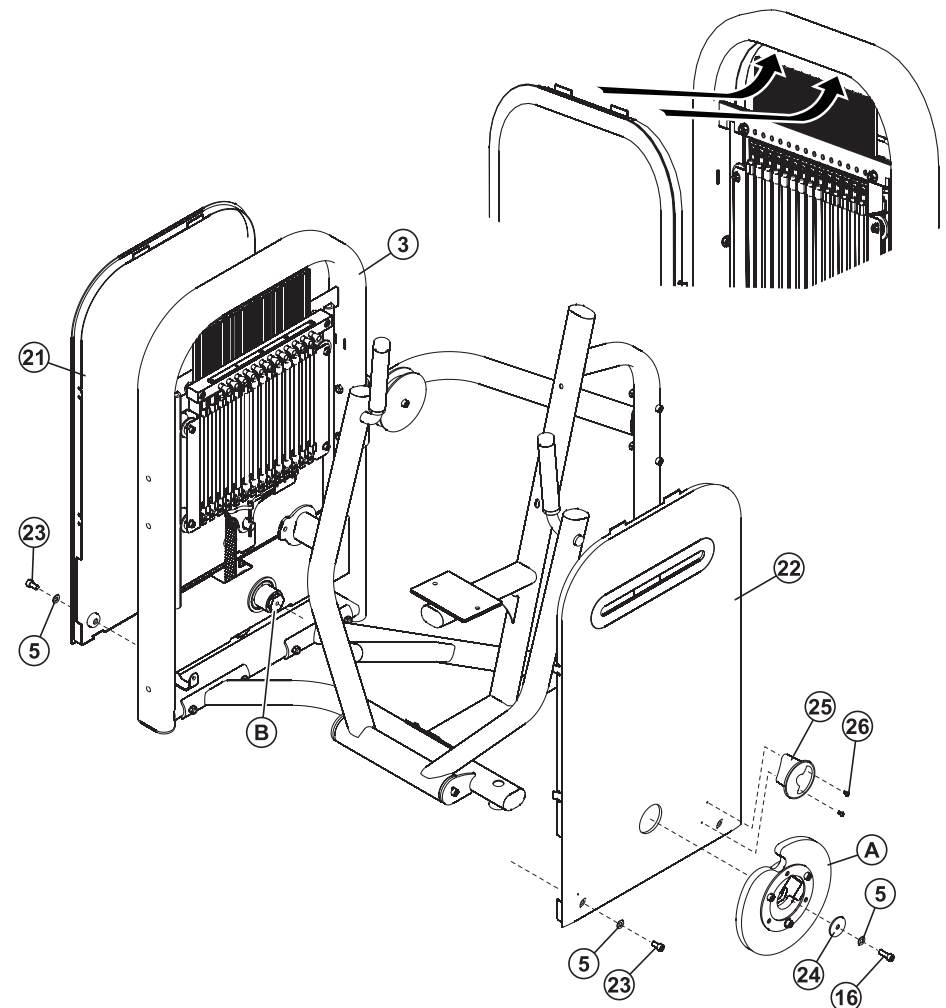

10. Attach the SEAT PAD (27) to the SEAT FRAME (7) using two M10 X 25mm BOLTS (16) and two 3/8" SAE WASHERS (5). Tighten the BOLTS securely.
11. Attach the BACK PAD (28) to the SEAT FRAME (7) using two M10 X 35mm BOLTS (29) and two 3/8" SAE WASHERS (5). Tighten the BOLTS securely.

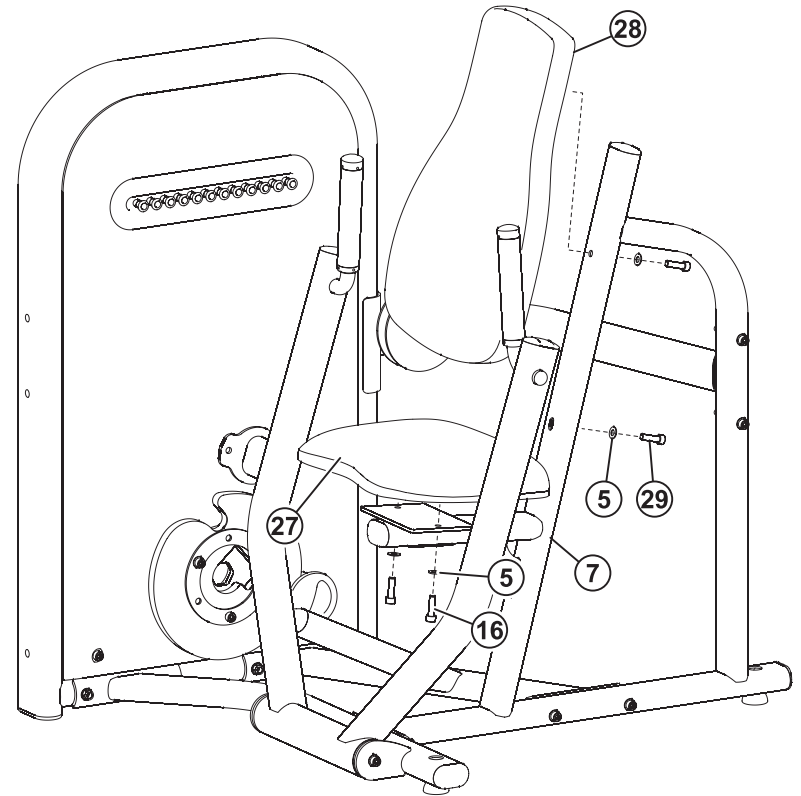

Chest Press

Assembly Instructions

NOTE: Some components have been removed from the illustration for clarity.

- Assemble one M10 HEX JAM NUT (30) onto one end of the CABLE (31) approximately 1/2". Assemble the ROD END BEARING (32) to the same end of the CABLE until it meets the M10 HEX JAM NUT. Tighten the M10 HEX JAM NUT securely.
- Loosely assemble the ROD END BEARING (32) of the CABLE (31) to the WORK ARM (15) using one M10 X 40mm BOLT (33), SPACER (34), 3/8" SAE WASHER (5) and M10 NYLOCK NUT (6)
- Route the CABLE (31) around the pulley on the TOP BRACE (9), over the CAM GUARD (25) and around the OUTPUT CAM ASSEMBLY (A). Insert the remaining end of the CABLE through the inner hole of the OUTPUT CAM ASSEMBLY.

Insert the CABLE RETAINING PLATE (35) over the end of the CABLE. Install two M8 HEX JAM NUTS (37) to the end of the CABLE.

Tighten the M8 HEX JAM NUTS until the WORKARM begins to move and all push pins still move in and out freely. Be sure the HEX JAM NUTS are tight against each other.

- Attach the OUTPUT CAM COVER PLATE (36) to the OUTPUT CAM ASSEMBLY (A) using three M10 X 45mm BOLTS (20) and three 3/8" SAE WASHERS (5).
 - Place the unit in the intended place for use and check stability. If the unit is not stable, the FEET (C) can be adjusted by inserting or removing supplied SHIMS (38).
- To add or remove SHIMS, loosen the LEVELING FOOT BOLT (D) and NUT (6) until the desired shim(s) can be inserted or removed. Lightly tighten the BOLT and NUT. Do not over-tighten the BOLT and NUT.
- Install HOLE PLUGS in all open bolt holes.

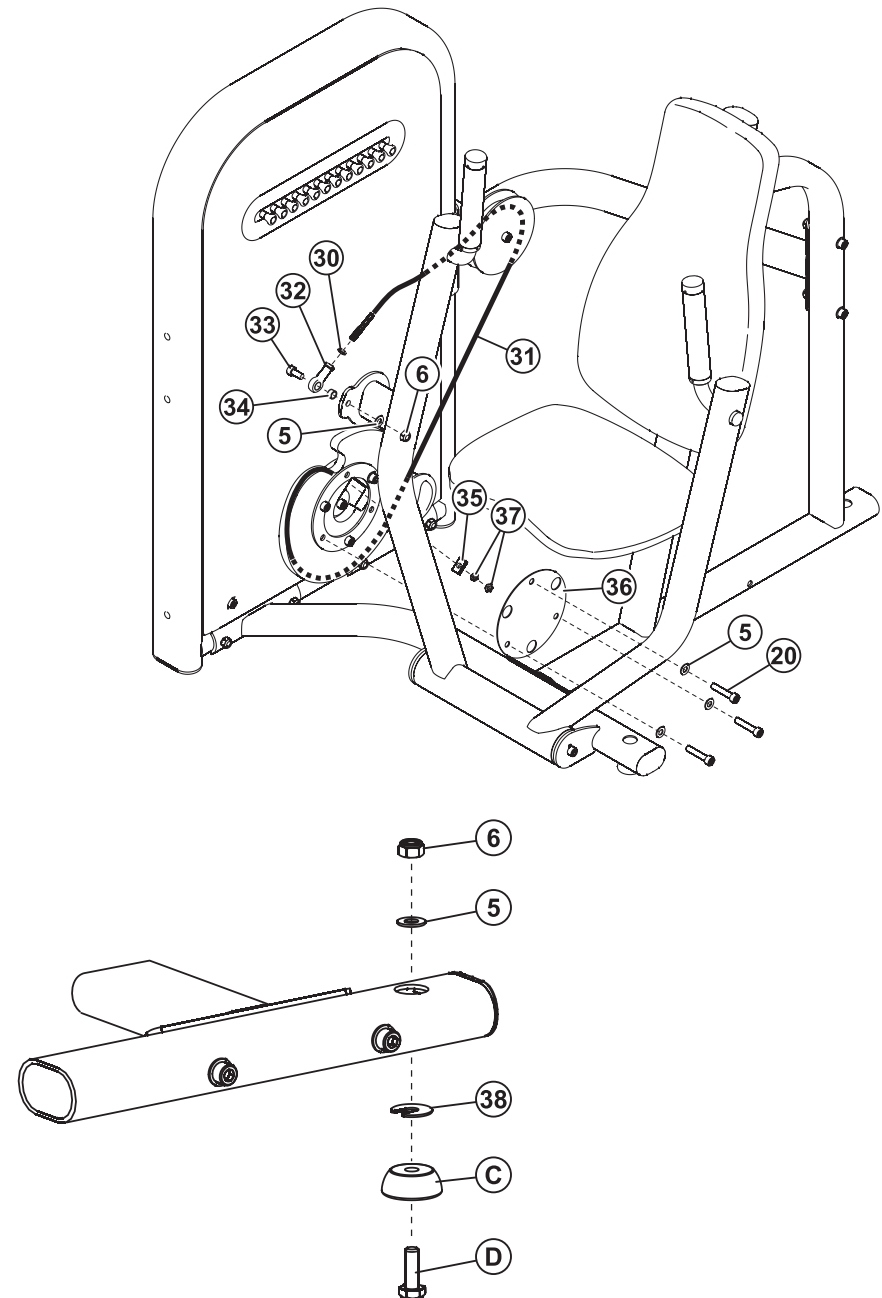

Free Manuals Download Website

<http://myh66.com>

<http://usermanuals.us>

<http://www.somanuals.com>

<http://www.4manuals.cc>

<http://www.manual-lib.com>

<http://www.404manual.com>

<http://www.luxmanual.com>

<http://aubethermostatmanual.com>

Golf course search by state

<http://golfingnear.com>

Email search by domain

<http://emailbydomain.com>

Auto manuals search

<http://auto.somanuals.com>

TV manuals search

<http://tv.somanuals.com>