

LifeFitness

F3-XX00-0102

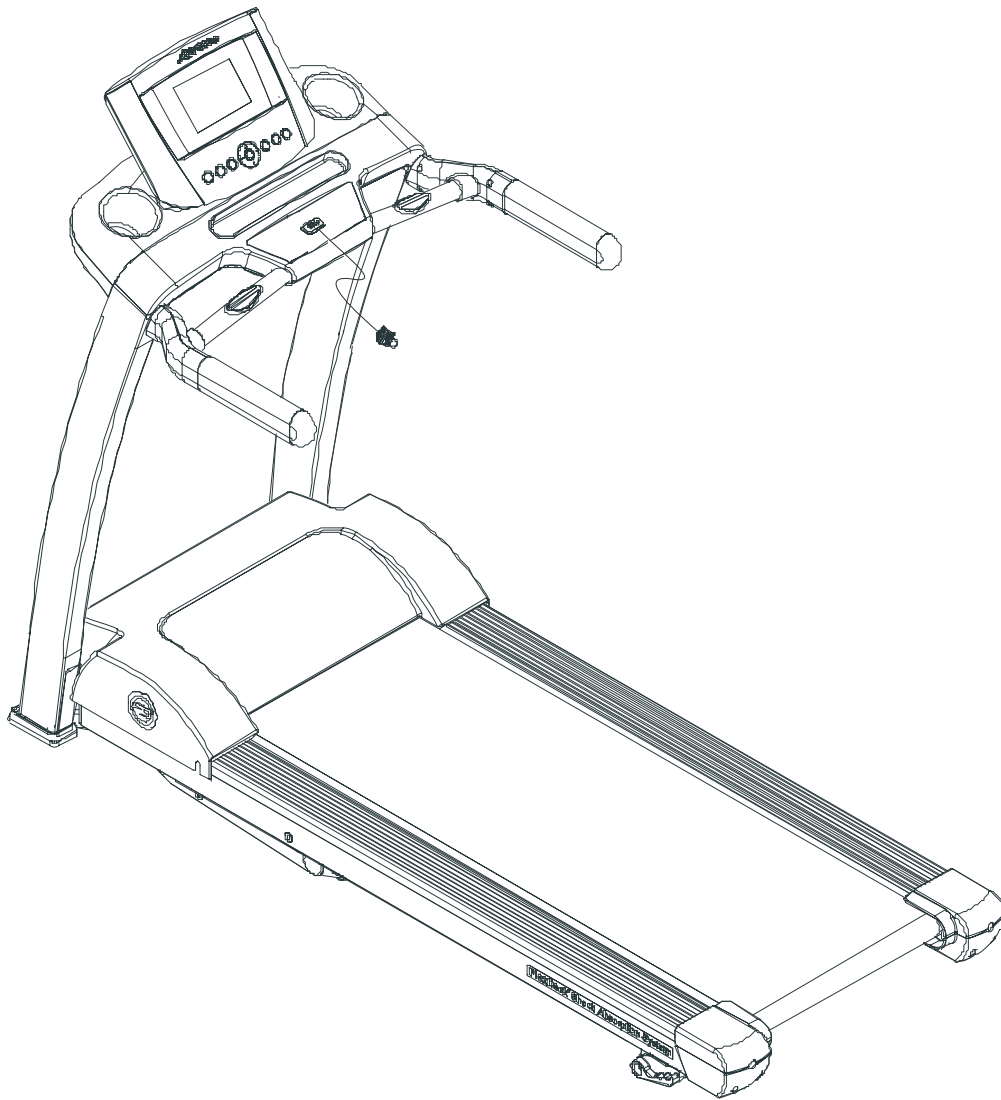

Customer Support Services PARTS MANUAL 19

26 Sep 2011

Contents

Uprights.....	3
Console Base Assembly.....	4
Belt, Deck, and Motor Cover Assembly.....	5
Deck Cushions, Haft Release, and Rear Wheels.....	6
Drive Motor, Lift Motor, and Motor Controller Assemblies.....	7
Lift Frame Assembly.....	8
Moving Wheels and Feet.....	10
Gas Shocks and Back Shroud.....	11
Cables and Line Cord.....	12
Wiring Diagram.....	13

Uprights

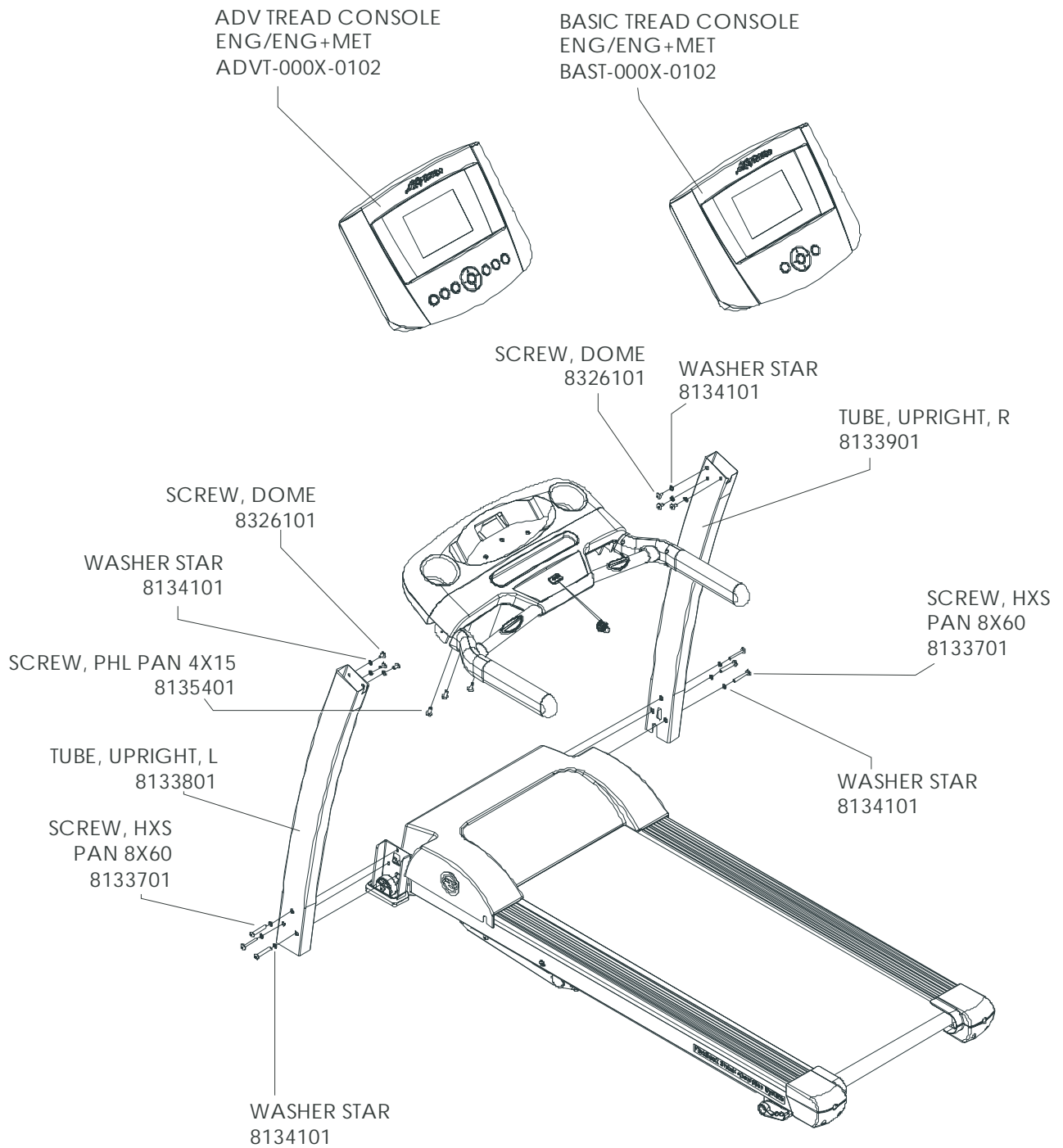

Console Base Assembly

*Parts with asterisks are included in the Console Base Assembly (part no. 8376301).

- *Interconnect Board
8126501
- *Heart Rate Contact Board
8126601
- *Reed Switch
8136501

*Console Base Membrane
Switch w/Overlay,
Domestic Only
8376801

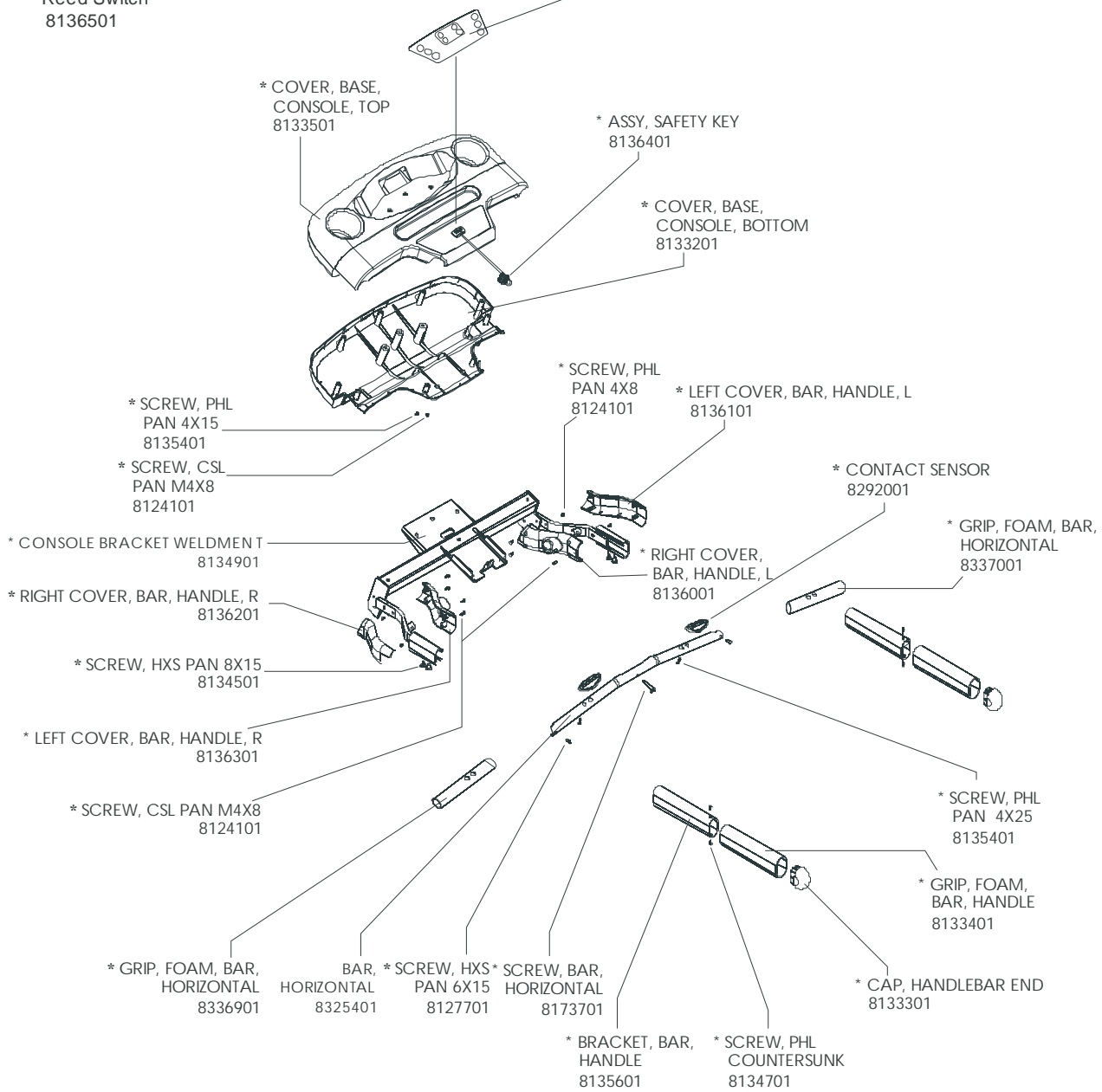

Belt, Deck, and Motor Cover Assembly

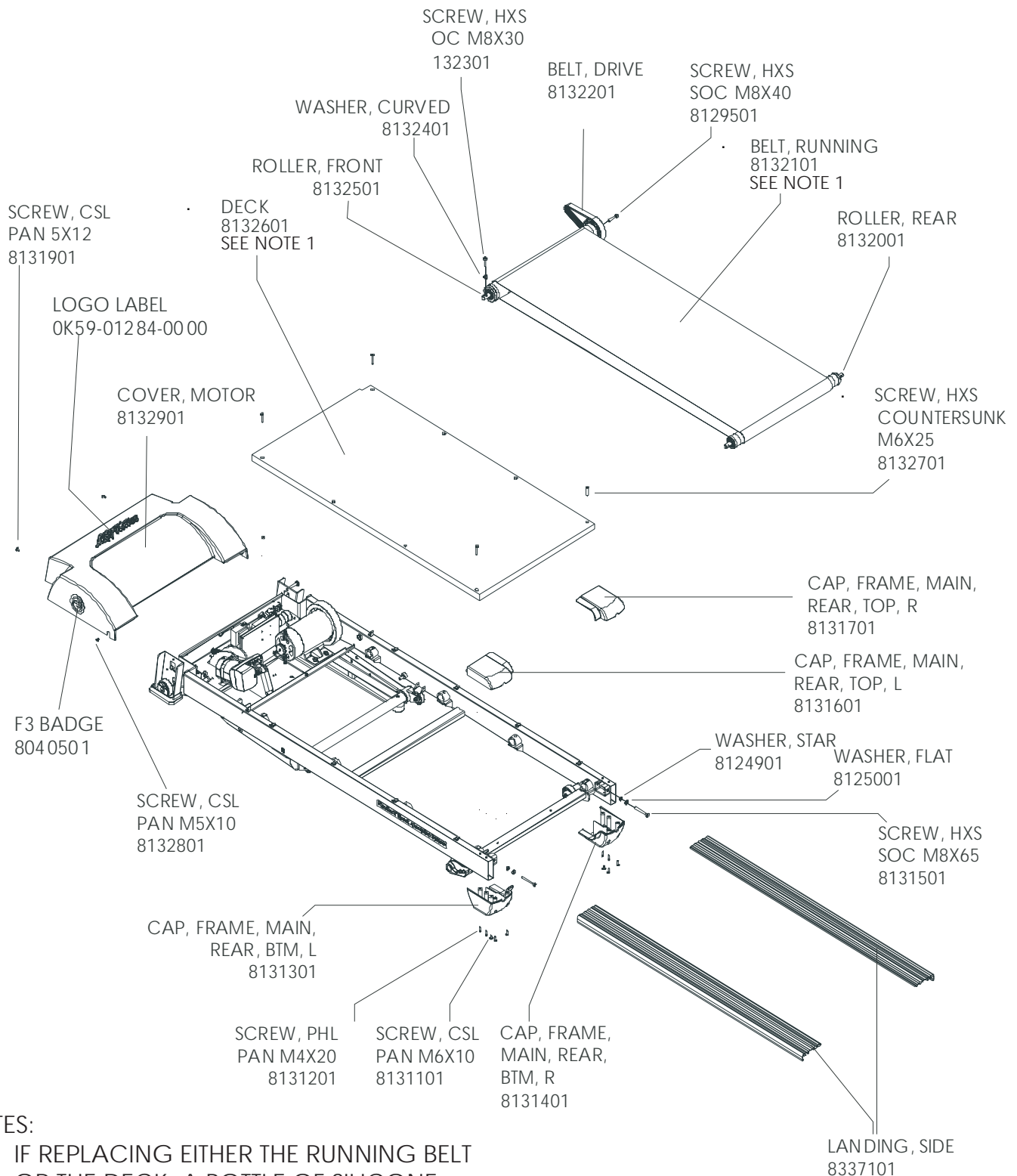

NOTES:

1. IF REPLACING EITHER THE RUNNING BELT OR THE DECK, A BOTTLE OF SILICONE (PART # 8168601) MUST BE ORDERED.

Deck Cushions, Haft Release, and Rear Wheels

*Parts with asterisks are included in the F3 Service Rear Wheels Assembly (part no. 8161501).

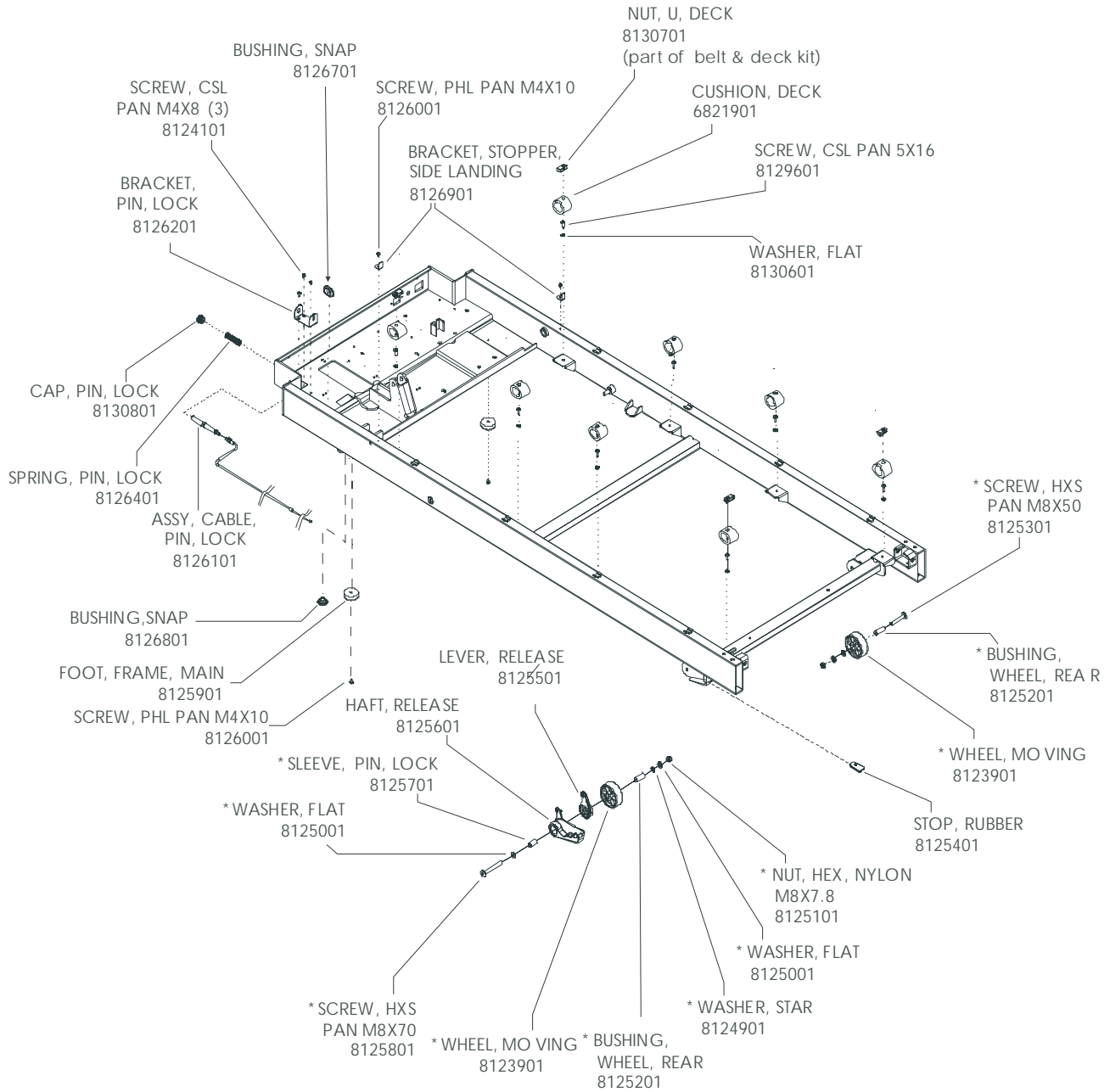

Drive Motor, Lift Motor, and Motor Controller Assemblies

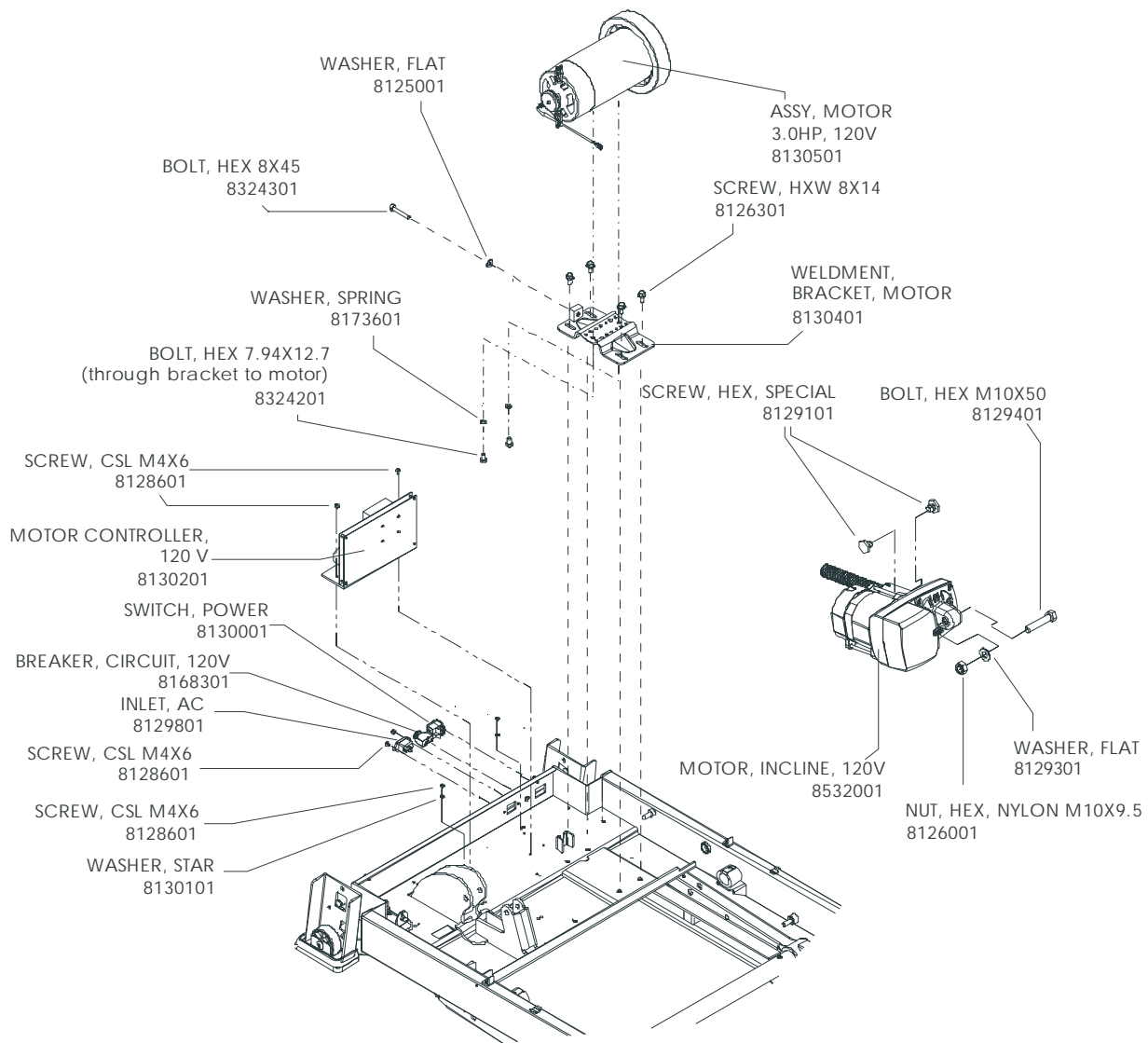

Lift Frame Assembly

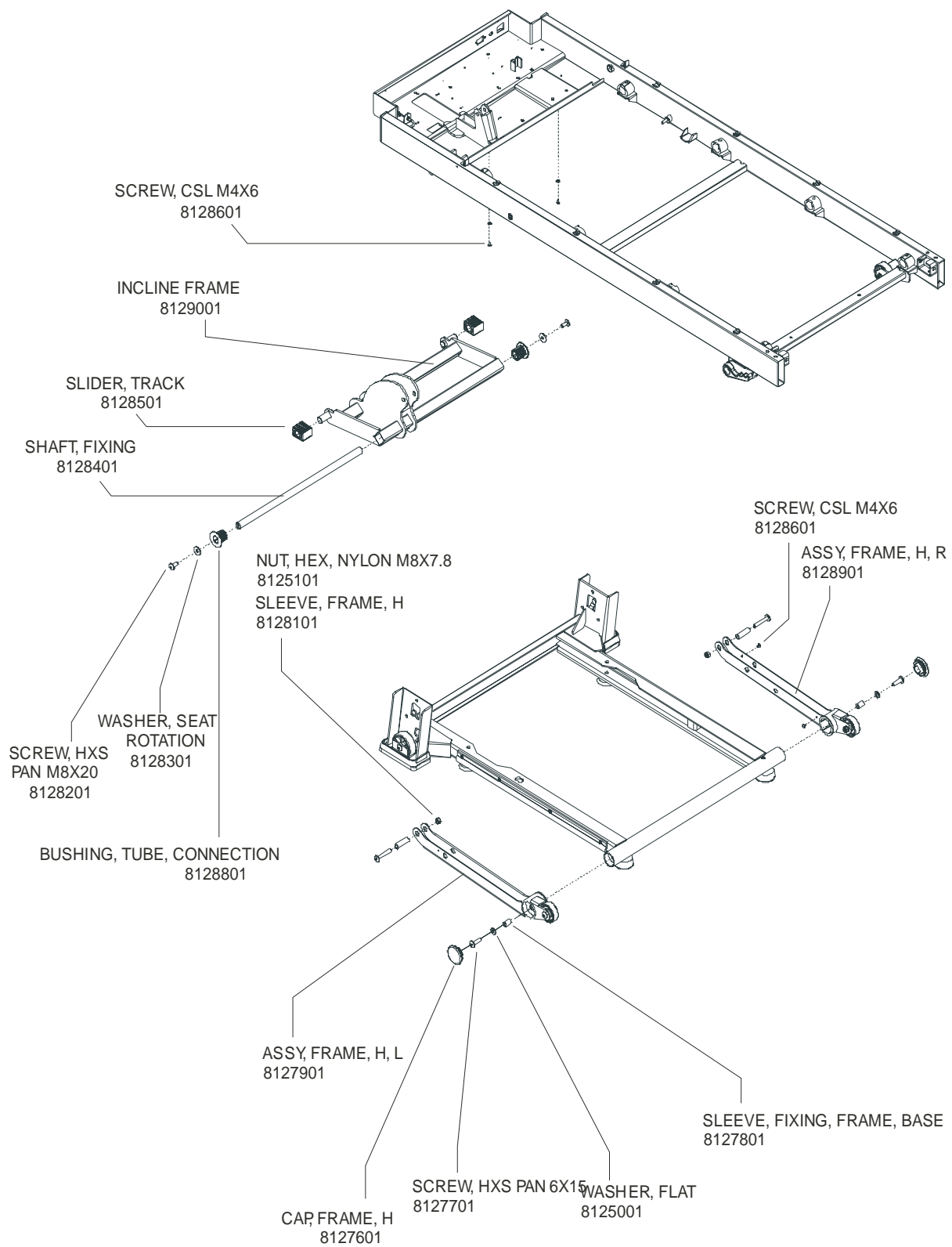

Lift Frame Assembly - Continued

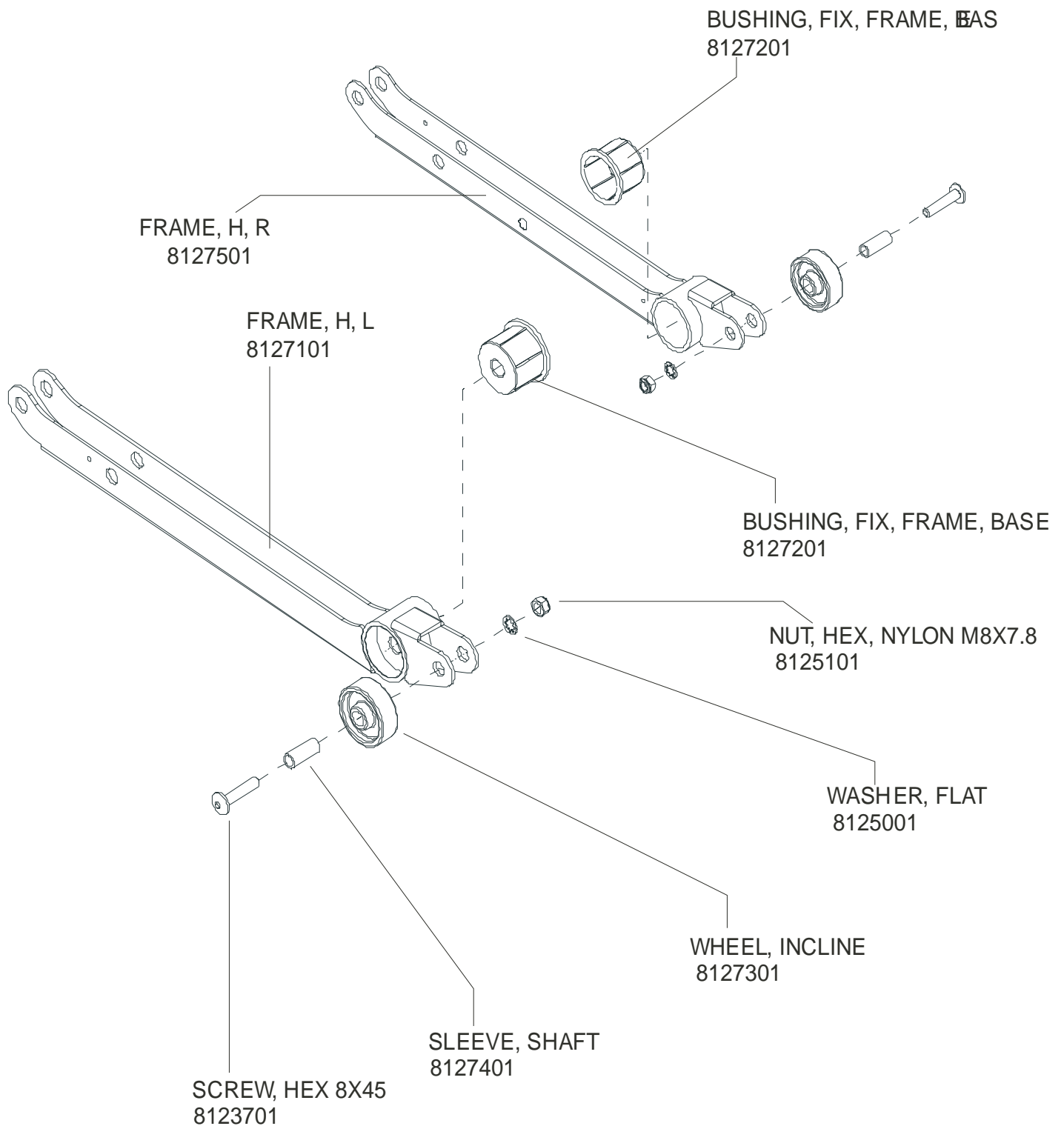

Moving Wheels and Feet

* Parts with asterisks are included in the F3 Service, Front Wheels Assembly (part no. 8161401).

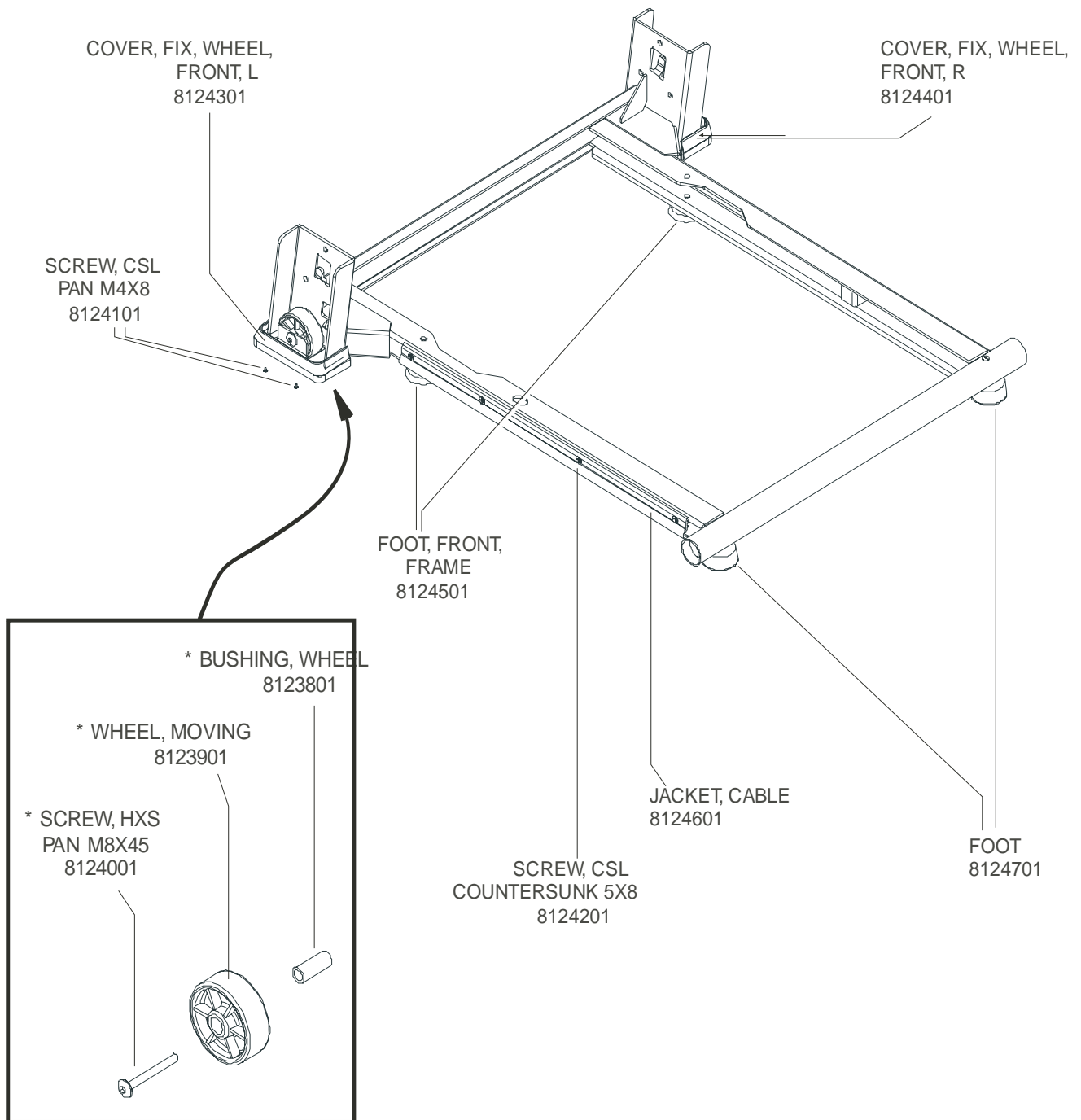

Gas Shocks and Back Shroud

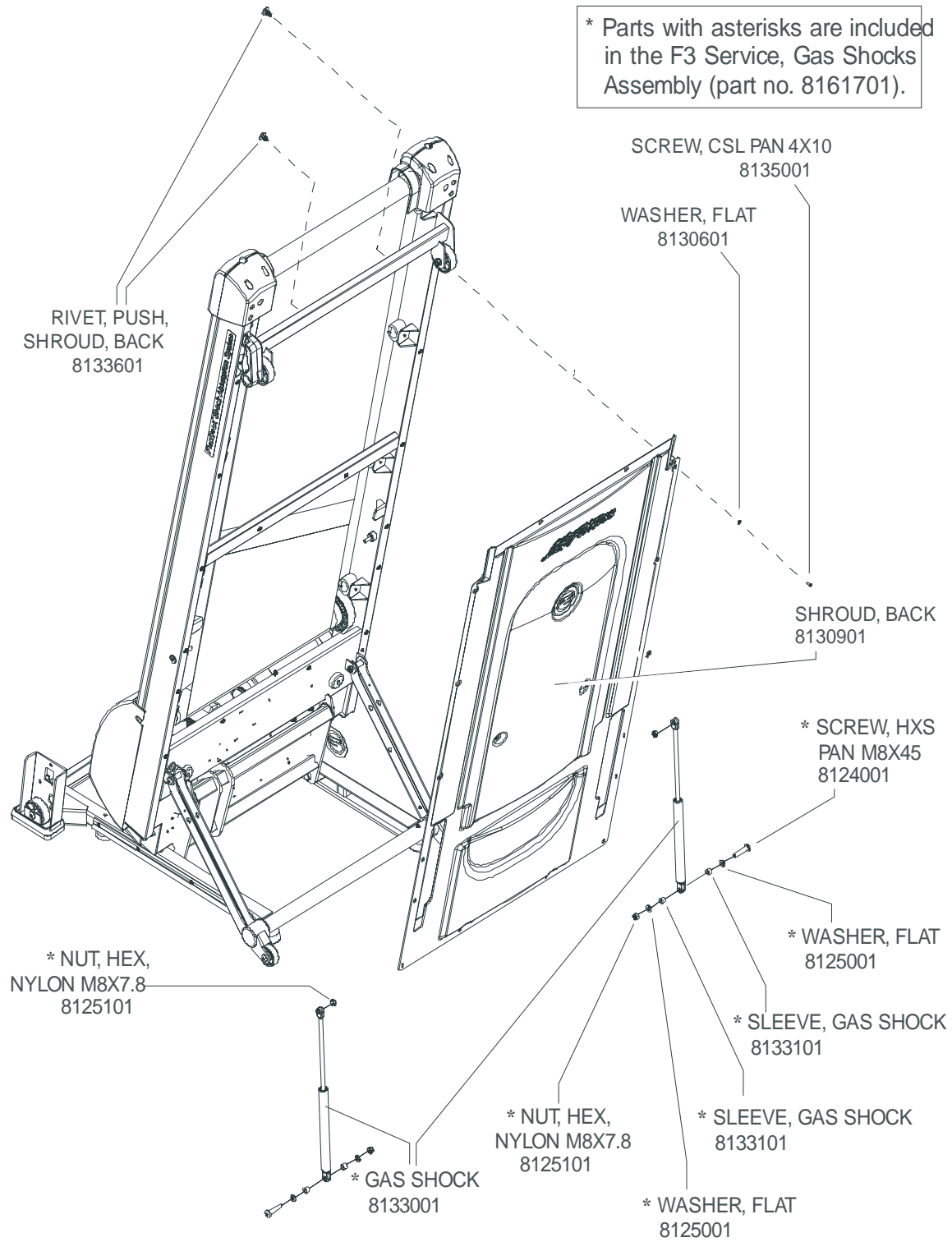

Cables and Line Cord

PART NUMBER	DESCRIPTION	QTY
8119401	USER MANUAL ENGLISH	1
8174701	LINE CORD,U.S. - HEAO005096	1
8168601	BOTTLE, SERVICE SILICONE, 0006560	1
8174001	CABLE 1, CONSOLE, INTERCONNECT	1
8174101	CABLE 2, CONSOLE, INTERCONNECT	1
8174201	CABLE, CONSOLE, UPRIGHT 63528 - HEAM008934	1
8174301	CABLE, UPRIGHT 63529 - HEAM005935	1
8174401	CABLE, CONTROLLER, UPRIGHT 63530 - HEAM005936	1
8168601	BOTTLE, SERVICE SILICONE, 0006560	1
8186301	TOUCH UP PAINT	1

F3 Consumer Treadmill Wiring Diagram (120V Only)

F3-XX00-0102

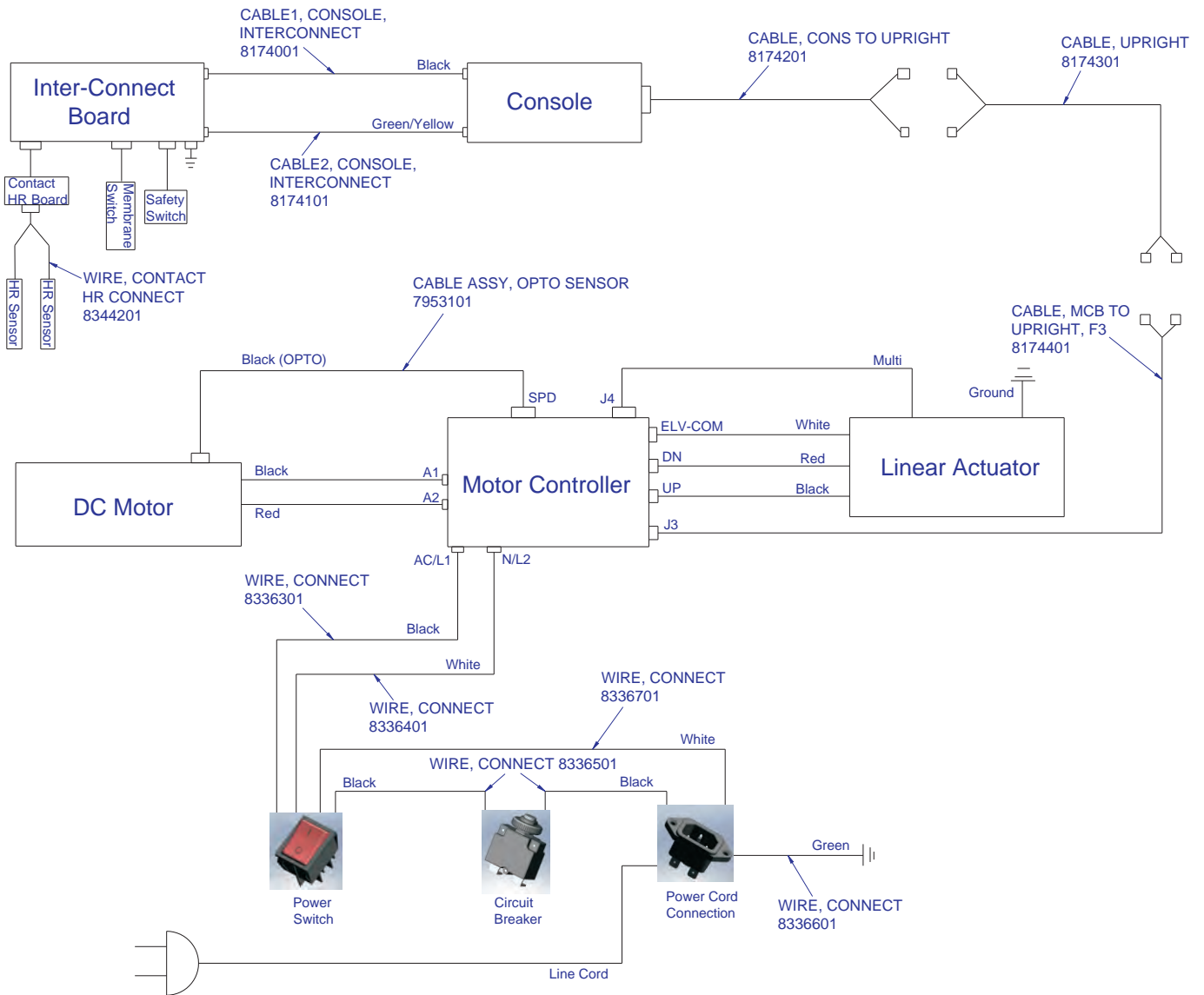

Free Manuals Download Website

<http://myh66.com>

<http://usermanuals.us>

<http://www.somanuals.com>

<http://www.4manuals.cc>

<http://www.manual-lib.com>

<http://www.404manual.com>

<http://www.luxmanual.com>

<http://aubethermostatmanual.com>

Golf course search by state

<http://golfingnear.com>

Email search by domain

<http://emailbydomain.com>

Auto manuals search

<http://auto.somanuals.com>

TV manuals search

<http://tv.somanuals.com>