

Classic Series Treadmill

OPERATION MANUAL



LifeFitness

CORPORATE HEADQUARTERS

5100 River Road
Schiller Park, Illinois 60176 • U.S.A.
+1.847.288.3300 • FAX: +1.847.288.3703
+1.800.735.3867 (Toll-free within U.S.A., Canada)
Global Website: www.lifefitness.com

INTERNATIONAL OFFICES

AMERICAS

North America Life Fitness Inc.

5100 N River Road
Schiller Park, IL 60176 U.S.A
Telephone: +1(847) 288 3300
Fax: +1(847) 288 3703
Service Email: internationalservicesupport@lifefitness.com
Sales/Marketing Email: commercialsales@lifefitness.com
Operating Hours: 7:00 am-6:00 pm (CST)

Brazil Life Fitness Do Brazil

Av. Dr. Dib Sauaia Neto 1478
Alphaville, Barueri, SP
06465-140
BRAZIL
Telephone: (800) 773 8282
Fax: (+55) 11.4133.2893
Service Email: suporte@lifefitness.com.br
Sales/Marketing Email: lifefitness@lifefitness.com.br
Operating Hours: 8:30 am-17:30 pm (BRT)

Latin America & Caribbean* Life Fitness Inc.

5100 N River Road
Schiller Park, IL 60176 U.S.A
Telephone: +1(847) 288 3300
Fax: +1(847) 288 3703
Service Email: internationalservicesupport@lifefitness.com
Sales/Marketing Email: commercialsales@lifefitness.com
Operating Hours: 8:00am-5:00pm (CST)

EUROPE, MIDDLE EAST, & AFRICA (EMEA)

Netherlands & Luxemburg Life Fitness Atlantic BV

Bijdorpplein 25-31
2992 LB Barendrecht
THE NETHERLANDS
Telephone: (+31) 180 646 666
Fax: (+31) 180 646 699
Service Email: service.benelux@lifefitness.com
Sales/Marketing Email: marketing.benelux@lifefitness.com
Operating Hours: 9.00h-17.00h (CET)

United Kingdom & Ireland Life Fitness UK LTD

Queen Adelaide
Ely, Cambs, CB7 4UB
Telephone: General Office (+44) 1353.666017
Customer Support (+44) 1353.665507
Fax: (+44) 1353.666018
Service Email: uk.support@lifefitness.com
Sales/Marketing Email: life@lifefitness.com
Operating Hours:
General Office: 9.00am - 5.00pm (GMT)
Customer Support: 8.30am - 5.00pm (GMT)

Germany & Switzerland Life Fitness Europe GMBH

Siemensstrasse 3
85716 Unterschleissheim
GERMANY
Telephone: (+49) 89.31 77 51.0 (Germany)
(+41) 0848 000 901 (Switzerland)
Fax: (+49) 89.31 77 51.99 (Germany)
(+41) 043 818 07 20 (Switzerland)
Service Email: kundendienst@lifefitness.com
Sales/Marketing Email: kundenberatung@lifefitness.com
Operating Hours: 9.00h-17.00h (CET)

Austria Life Fitness Austria

Vertriebs G.m.b.H.
Dückerstrasse 7-9/3/36
1220 Vienna
AUSTRIA
Telephone: (+43) 1.61.57.198
Fax: (+43) 1.61.57.198.20
Service Email: kundendienst@lifefitness.com
Marketing/Sales Email: kundenberatung@lifefitness.com
Operating Hours: 9.00h-17.00h (CET)

Spain Life Fitness IBERIA

C/Frederic Mompou 5,1ªª
08960 Sant Just Desvern Barcelona
SPAIN
Telephone: (+34) 936 724 660
Fax: (+34) 936 724 670
Service Email: info.iberia@lifefitness.com
Sales/Marketing Email: info.iberia@lifefitness.com
Operating Hours:
9.00h-18.00h (Monday-Thursday) (GMT)
8.30h-15.00h (Friday) (GMT)

Italy Life Fitness ITALIA S.R.L.

Via Crivellin 7/N
37010 Affi Verona
ITALY
Telephone: (+39) 045.7237811
Fax: (+39) 045.7238197
Service Email: assistenza@lifefitness.com
Sales/Marketing Email: info@lifefitnessitalia.com
Operating Hours: 8.30h -18.00h (CET)

Belgium Life Fitness Benelux NV

Parc Industriel de Petit-Rechain
4800 Verviers
BELGIUM
Telephone: (+32) 87 300 942
Fax: (+32) 87 300 943
Service Email: service.benelux@lifefitness.com
Sales/Marketing Email: marketing.benelux@lifefitness.com
Operating Hours: 9.00h -17.00h (CET)

All Other EMEA countries & distributor business C-EMEA*

Bijdorpplein 25-31
2992 LB Barendrecht
THE NETHERLANDS
Telephone: (+31) 180 646 666
Fax: (+31) 180 646 699
Service Email: service.db.cemea@lifefitness.com
Sales/Marketing Email: marketing.db.cemea@lifefitness.com
Operating Hours: 9.00h-17.00h (CET)

ASIA PACIFIC (AP)

Japan Life Fitness Japan

Nippon Brunswick Bldg., #8F
5-27-7 Sendagaya
Shibuya-Ku, Tokyo
JAPAN 151-0051
Telephone: (+81) 3.3359.4309
Fax: (+81) 3.3359.4307
Service Email:
service@lifefitnessjapan.com
Sales/Marketing Email
sales@lifefitnessjapan.com
Operating Hours: 9.00h-17.00h (GMT)

China and Hong Kong Life Fitness Asia Pacific LTD

Room 2610, Miramar Tower
132 Nathan Road
Tsimshatsui, Kowloon
HONG KONG
Telephone: (+852) 2891.6677
Fax: (+852) 2575.6001
Service Email: HongKongEnquiry@lifefitness.com
Sales/Marketing Email: ChinaEnquiry@lifefitness.com
Operating Hours: 9.00h-18.00h (GMT)

All Other Asia Pacific countries & distributor business Asia Pacific*

Room 2610, Miramar Tower
132 Nathan Road
Tsimshatsui, Kowloon
HONG KONG
Telephone: (+852) 2891.6677
Fax: (+852) 2575.6001
Service Email: HongKongEnquiry@lifefitness.com
Sales/Marketing Email: ChinaEnquiry@lifefitness.com
Operating Hours: 9.00h-18.00h (GMT)

Before using this product, it is essential to read this ENTIRE operation manual and ALL installation instructions.

It describes equipment setup and instructs members on how to use it correctly and safely.

Avant d'utiliser ce produit, il est indispensable de lire ce manuel d'utilisation dans son INTÉGRALITÉ, ainsi que TOUTES les instructions d'installations.

Ce manuel explique comment installer l'équipement et comment l'utiliser correctement et sans danger.

FCC Warning - Possible Radio / Television Interference

NOTE: *This equipment has been tested and found to comply with the limits for a Class A digital device, pursuant to part 15 of the FCC rules. These limits are designed to provide reasonable protection against harmful interference when the equipment is operated in a commercial environment. This equipment generates, uses and can radiate radio frequency energy, and if not installed and used in accordance with the instruction manual, may cause harmful interference to radio communications. Operation of this equipment in a residential area is likely to cause harmful interference in which case the user will be required to correct the interference at his own expense.*

Class SB (Studio): Professional and / or commercial use.



CAUTION: Any changes or modifications to this equipment could void the product warranty.

Mise en garde : tout changement ou toute modification de ce matériel peut annuler la garantie du produit.

Any service, other than cleaning or user maintenance, must be performed by an authorized service representative. There are no user serviceable parts.

TABLE OF CONTENTS

Section	Description	Page
1.	Getting Started	.5
1.1	Important Safety Instructions	.5
1.2	Setup	.9
	Electrical Power Requirements // Grounding Instructions // How to Position and Stabilize the Life Fitness Treadmill Power Switch // Centering the Belt // Fitness Networking // Power Cord Routing	
2.	The Display Console	.12
2.1	Display Console Overview	.12
2.2	Display Console Description	.12
2.3	Reading Rack and Accessory Trays	.14
3.	Heart Rate Zone Training® Exercise	.15
3.1	Why Heart Rate Zone Training® Exercise ?	.15
3.2	Heart Rate Monitoring	.16
	The Lifepulse™ System	
	The Optional Heart Rate Chest Strap	
4.	The Workouts	.17
4.1	Workout Overviews	.17
4.2	Using the Workouts	.18
	Life Fitness Treadmill Workout Setup Steps	
4.3	Workout Descriptions	.20
	Quick Start // Manual // Random // Fat Burn // Cardio // Hill // Custom Workouts // Calories Goal // Distance Goal // Time in Zone Goal // Sport Training™ // Heart Rate Hill™ // Heart Rate Interval™	
	Extreme Heart Rate™ // Fit Test // Fitness Tests // <i>Life Fitness Fit Test, Army PFT, Navy PRT, Marines PFT, Airforce PRT, Gerkin, PEB</i> // Speed Interval	
4.4	Maximizing Workouts on a Life Fitness Treadmill	.29
	Selecting a Level // Using InstaPace™ Feedback // Using ZerOut™ Speed Control // Cool-Down // Dimming	
4.5	Logging On to the Network	.30
5.	The Manager's Configuration	.31
5.1	Entering and Using the Manager's Configuration	.31
5.2	Configuration Settings	.32
	Programming Custom Workouts // Using Quick Start Disable // Using the Start Message Setup // Creating/Changing a Start Message // Saving a Start Message // Erasing a Start Message // Marathon Mode // User Language Select	
6.	Service and Technical Data	.35
6.1	Preventive Maintenance Tips	.35
6.2	Preventive Maintenance Schedule	.36
6.3	Troubleshooting the Treadmill	.37
6.4	Troubleshooting the Optional Heart Rate Chest Strap	.40
6.5	How to Adjust and Tension the Striding Belt	.41
	The Belt Tensioning Bolts // Tracking (Centering) a Striding Belt // Tensioning an Existing Striding Belt	
6.6	Proactive Belt Wear Notification	.42
6.7	How to Obtain Product Service	.42
7.	Specifications	.43
7.1	Life Fitness Classic Series Treadmill Specifications	.43
7.2	Life Fitness Classic Series Treadmill Warranty Information	.44

© 2008 Life Fitness, a division of Brunswick Corporation. All rights reserved. Life Fitness, Lifecycle, FlexDeck, and Heart Rate Zone Training are registered trademarks, and Sport Training, Heart Rate Hill, Heart Rate Interval, Extreme Heart Rate, InstaPace, ZerOut, Lifepulse, MagnaDrive, Lifespring, and Custom Plus are trademarks of Brunswick Corporation. Polar is a registered trademark of Polar Electro, Inc. Cardio Theater is a registered trademark of Cardio Theater Holdings and a wholly owned subsidiary of ClubCom corporation. Broadcast Vision is a trademark of Broadcast Vision, Inc. Fitlinxx is a registered trademark of the Integrated Fitness Corp. Any use of these trademarks, without the express written consent of Life Fitness or the corresponding companies is forbidden.

This Operation Manual describes the functions of the following product:

Classic Series Treadmill

See "Specifications" in this manual for product specific features.

Statement of Purpose: The treadmill is an exercise machine that enables users to walk or run, in place, on a moving surface.

Life Fitness **STRONGLY** recommends seeing a physician for a complete medical exam before undertaking an exercise program, particularly if the user has a family history of high blood pressure or heart disease, or is over the age of 45, or smokes, has high cholesterol, is obese, or has not exercised regularly in the past year.

If, at any time while exercising, the user experiences faintness, dizziness, pain, or shortness of breath, he or she must stop immediately.

Life Fitness recommande **FORTEMENT** de consulter un médecin pour subir un examen médical complet avant de commencer tout programme d'exercice, et tout particulièrement si l'utilisateur a des antécédents familiaux d'hypertension ou de troubles cardiaques, s'il a plus de 45 ans, s'il fume, s'il a du cholestérol, s'il est obèse ou n'a pas fait d'exercice régulièrement depuis un an.

Si, pendant l'utilisation de l'appareil, l'utilisateur ressent un malaise, des vertiges, des douleurs ou des difficultés à respirer, il doit s'arrêter immédiatement.

1 GETTING STARTED

1.1 IMPORTANT SAFETY INSTRUCTIONS

Read all instructions before using the treadmill.

- **DANGER:** To reduce the risk of electrical shock, always unplug this Life Fitness product before cleaning or attempting any maintenance activity.
- **WARNING:** To reduce the risk of burns, fire, electric shock, or injury, it is imperative to connect each product to a properly grounded electrical outlet.
- **WARNING:** Keep the area six feet (two meters) by three feet (one meter) behind the treadmill clear of any obstructions, including walls, furniture, and other equipment.
- **WARNING:** Be sure the emergency stop lanyard is clipped to the user and in proper position on the treadmill before beginning any workout.
- To disconnect, turn power OFF at the ON/OFF switch, then remove plug from electrical outlet.
- Never operate a Life Fitness product if it has a damaged power cord or electrical plug, or if it has been dropped, damaged, or even partially immersed in water. Contact Life Fitness Customer Support Services.
- Position this product so that the power cord plug is accessible to the user.
- Keep the power cord away from heated surfaces. Do not pull the equipment by the power cord or use the cord as a handle. Do not run the power cord on the floor under or along the side of the treadmill. Refer to Section 1.2 for proper power cord routing.
- If the electrical supply cord is damaged, it must be replaced by the manufacturer, an authorized service agent, or a similarly qualified person to avoid a hazard.
- Do not use this product in areas where aerosol spray products are being used or where oxygen is being administered. Such substances create the danger of combustion and explosion.
- Always follow the console instructions for proper operation.
- Close supervision is necessary when used near children, invalids or disabled persons.
- Do not use this product outdoors, near swimming pools or in areas of high humidity.
- Never operate a Life Fitness product with the air openings blocked. Keep air openings free of lint, hair, or any obstructing material.
- Never insert objects into any opening in this product. If an object should drop inside, turn off the power, unplug the power cord from the outlet, and carefully retrieve it. If the item cannot be reached, contact Life Fitness Customer Support Services.
- Never place liquids of any type directly on the unit, except in an accessory tray or holder. Containers with lids are recommended.
- Do not use this product in bare feet. Always wear shoes. Wear shoes with rubber or high-traction soles. Do not use shoes with heels, leather soles, cleats or spikes. Make sure no stones are embedded in the soles.
- Keep all loose clothing, shoelaces, and towels away from moving parts.
- Do not reach into, or underneath, the unit or tip it on its side during operation.
- Handrails may be held to enhance stability as needed, but are not for continuous use.
- Never mount or dismount the treadmill while the running belt is moving. Use the handrails whenever additional stability is required. In case of an emergency, such as tripping, grasp the handrails, and place the feet on the side platforms.
- Never walk or jog backwards on the treadmill.

- When it is necessary to immobilize the treadmill, set the display to read SELECT WORKOUT. (Press the STOP key twice if not already there.) Then hold down the SPEED DOWN key and press the PAUSE key. The treadmill now displays “IMMOBILIZED”. In this state, the treadmill cannot be operated. The main motor and incline are disabled. The treadmill will remain in this state across resets, power cycles, etc. To restore normal operation, repeat the same key sequence: hold down the SPEED DOWN key, and press the PAUSE key. The treadmill will display “SELECT WORKOUT” again.
- Use this appliance only for its intended use as described in this manual. Do not use attachments that have not been recommended by the manufacturer.

**SAVE THESE INSTRUCTIONS
FOR FUTURE REFERENCE.**

1 DÉMARRAGE

1.1 CONSIGNES DE SÉCURITÉ IMPORTANTES

Lire toutes les instructions avant d'utiliser le tapis roulant.

- **DANGER:** Pour réduire les risques de décharge électrique, toujours débrancher cet appareil Life Fitness avant le nettoyage ou toute mesure d'entretien.
- **AVERTISSEMENT:** Pour réduire les risques de brûlures, d'incendies, de décharges électriques ou de blessures, chaque appareil doit absolument être branché sur une prise électrique correctement mise à la terre.
- **AVERTISSEMENT:** Conserver une zone de 2 m sur 1 m libre de toute obstruction derrière le tapis roulant (aucun mur, meuble ou autre appareil).
- **AVERTISSEMENT:** S'assurer que la dragonne d'arrêt d'urgence est attachée à l'utilisateur et fixée adéquatement au tapis roulant avant de commencer un exercice.
- Pour débrancher, mettre l'appareil hors tension au niveau de l'interrupteur d'alimentation, puis retirer la fiche de la prise électrique.
- Ne jamais faire fonctionner un produit Life Fitness dont la fiche ou le cordon d'alimentation est endommagé, ni aucun appareil qui serait tombé ou aurait été endommagé ou même partiellement plongé dans l'eau. Appeler le service clientèle de Life Fitness.
- Placer ce produit de manière à ce que l'utilisateur puisse accéder à la fiche du cordon d'alimentation.
- Tenir le cordon d'alimentation à l'écart de toute surface chauffée. Ne pas tirer l'appareil par le cordon d'alimentation; ne pas utiliser le cordon comme poignée. Ne pas faire passer le cordon sur le sol, sous le tapis roulant, ni le long de l'appareil. Se reporter à la section 1.2 pour la disposition adéquate du cordon d'alimentation.
- Si le cordon d'alimentation électrique est endommagé, il doit être remplacé par le fabricant, par un réparateur agréé ou par une personne qualifiée afin d'éviter tout danger.
- Ne pas utiliser ce produit dans des salles où des vaporisateurs aérosols sont employés ou bien où de l'oxygène est administré. Ces substances créent des risques de combustion et d'explosion.
- Les instructions de la console doivent toujours être suivies pour obtenir un fonctionnement correct.
- Une surveillance étroite est nécessaire si l'appareil est utilisé près d'enfants ou de personnes invalides ou handicapées.
- Ne pas utiliser ce produit à l'extérieur, près d'une piscine ou dans des endroits très humides.
- Ne jamais faire fonctionner d'appareil Life Fitness dont les orifices d'aération seraient bloqués. Les garder exempts de peluches, de cheveux ou de toute obstruction.
- Ne jamais rien insérer dans les ouvertures de cet appareil. Si un objet tombe à l'intérieur de l'appareil, couper l'alimentation électrique, débrancher le cordon de la prise et le récupérer avec précaution. S'il est impossible de l'atteindre, communiquer avec le service à la clientèle de Life Fitness.
- Ne jamais placer aucun liquide directement sur l'appareil, sauf dans le plateau pour accessoires ou un support prévu à cet effet. Il est recommandé d'utiliser des conteneurs munis de couvercles.
- Ne pas utiliser cet appareil pieds nus. Toujours porter des chaussures. Porter des chaussures avec des semelles en caoutchouc ou fournissant une très bonne adhérence. Ne pas utiliser de chaussures à talons, à semelles en cuir ou munies de crampons. S'assurer qu'aucun caillou n'est incrusté dans les semelles.
- Éloigner les vêtements lâches, les lacets et les serviettes des pièces en mouvement.
- Ne pas placer les mains sous l'appareil ou dans l'appareil, et ne pas le renverser sur le côté pendant le fonctionnement.
- Les rampes latérales peuvent servir à rétablir son équilibre, mais ne sont pas destinées à un usage continu.

- Ne jamais monter sur le tapis de course et ne pas en descendre jamais pendant qu'il tourne. Utiliser les rampes latérales afin de ne pas perdre l'équilibre. En cas d'urgence, par exemple, en cas de trébuchement ou de faux pas, saisir les barres latérales et placer les pieds sur les plates-formes latérales.
- Ne jamais marcher ni courir à reculons sur le tapis roulant.
- S'il est nécessaire d'immobiliser le tapis roulant, régler l'afficheur sur SELECT WORKOUT (SÉLECTIONNER EXERCICE). (Appuyer deux fois sur la touche REMISE À ZÉRO si l'afficheur n'en est pas déjà à ce point.) Maintenir ensuite la touche SPEED DOWN (RALENTISSEMENT) enfoncée et appuyer sur la touche PAUSE. L'appareil affiche désormais IMMOBILIZED (Immobilisé). Il ne peut alors plus fonctionner, Le moteur principal, le moteur en ligne et le cireur sont désactivés. Le tapis roulant restera immobilisé, même s'il est réinitialisé, mis hors tension, puis remis sous tension, etc. Le mode de fonctionnement normal ne peut être rétabli qu'au moyen de la même séquence de touches : maintenir la touche SPEED DOWN (RALENTISSEMENT) enfoncée et appuyer sur PAUSE. L'appareil affichera SELECT WORKOUT (SÉLECTIONNER EXERCICE) à nouveau.
- Cet appareil ne doit être employé que pour l'usage auquel il est destiné, conformément aux directives du manuel. Ne pas utiliser d'accessoires qui ne sont pas recommandés par le fabricant.

**CONSERVER CES INSTRUCTIONS
POUR TOUT USAGE ULTÉRIEUR.**

1.2 SETUP

Read the Operation Manual before setting up the Life Fitness Treadmill. Place the treadmill where it will be used before beginning the setup procedure.

ELECTRICAL POWER REQUIREMENTS

The Life Fitness Treadmill requires a dedicated* line according to the electrical configurations listed in the chart below.

Supply Voltage (VAC)	Frequency (Hz)	Rated Current (Amps)
100	50 / 60	18
120	50 / 60	18
200	50 / 60	9
220	50 / 60	9
230	50 / 60	9
240+	50 / 60	9

* One individual branch circuit for each treadmill per NEC article 210-21 (b) (1) and 210-23 (or other appropriate, country specific electrical compliance guidelines). The hot and neutral wires must each be routed independently (not looped or tied to other circuits.)"

NOTE: Do not modify the plug provided with this product. If the plug does not fit into an available electrical outlet, have a proper outlet installed by a qualified electrician.

GROUNDING INSTRUCTIONS

This Life Fitness product must be properly grounded. If the unit malfunctions or breaks down, proper grounding provides a path of least resistance for the electric current, which reduces the risk of shock to anyone touching or using the equipment. Each unit is equipped with an electrical cord, which includes an equipment grounding conductor and a grounding plug. The plug must be inserted into an outlet that has been properly installed and grounded in accordance with all local codes and ordinances.

A temporary adapter MUST NOT BE USED to connect this plug to a two-pole receptacle in North America. If a properly grounded, 20-amp outlet is not available, one must be installed by a qualified electrician. Models drawing 16 amps or more must be installed on a dedicated line.

IL EST ABSOLUMENT INTERDIT d'employer un adaptateur temporaire pour brancher cette fiche sur une prise bipolaire en Amérique du Nord. Si aucune prise de 20 A correctement mise à la terre n'est disponible, en faire installer une par un électricien qualifié. Les modèles utilisant 16 A ou plus doivent être branchés sur un circuit spécialisé.

DANGER: A risk of electrical shock may result from improper connection of the equipment-grounding conductor. Check with a qualified electrician if in doubt as to proper grounding technique. **DO NOT** modify the plug provided with the product. If it will not fit an electrical outlet, have a proper outlet installed by a qualified electrician. Any modification to the electrical plug will result in a voided warranty.

Un branchement incorrect du conducteur de mise à la terre peut entraîner des risques de décharge électrique. Consulter un électricien si des doutes subsistent quant à la technique de mise à la terre. NE PAS MODIFIER la fiche fournie avec l'appareil. Si elle ne s'adapte pas à une prise, faire installer une prise correcte par un électricien qualifié. Toute modification à la fiche annule la garantie.

HOW TO POSITION AND STABILIZE THE LIFE FITNESS TREADMILL

Following all safety instructions in Section 1.1, move the treadmill to the location in which it will be used. See Section 7, titled *Specifications*, for the dimensions of the footprint. Allow a distance of eight inches, or 21 centimeters, between the treadmill and other units on either side. Allow a distance of six feet, or two meters, from the rear of the treadmill to any object or surface.

After placing the unit where it will be used, check its stability. If there is even a slight rocking motion or the unit is not stable, determine which stabilizing leg is not resting on the floor. To adjust, loosen the JAM NUT (A), and turn the STABILIZING LEG (B) until the rocking motion ceases, and both stabilizing legs rest firmly on the floor. Retighten the JAM NUT.

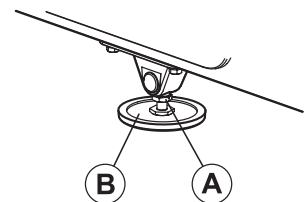

NOTE: It is extremely important that the stabilizing leg be correctly adjusted for proper operation. An unbalanced unit may cause striding belt misalignment. A bubble level is recommended to ensure proper leveling.

POWER SWITCH

Located on the front panel at the base of the treadmill, the ON/OFF switch has two positions: "1" (one) for ON and "0" (zero) for OFF.

CENTERING THE BELT

After installing and levelling the treadmill, check the belt to ensure that it is tracking properly. First, plug the power cord into an appropriate outlet. See *Electrical Requirements* at the beginning of this section for details. Then, turn the treadmill ON.

Have one person stand on the platforms on either side of the treadmill frame. Do not stand on the belt at this time. Press the QUICK START key, and increase the speed to 4.0 miles per hour (MPH), or 6.4 kilometers per hour (KPH), using the SPEED UP arrow.

If the striding belt moves to the right while it is running, have a second person turn the right tension bolt a quarter-turn clockwise, and then turn the left tension bolt (A) a quarter-turn counter-clockwise. See the illustration. This action sets the striding belt tracking back to center of the roller.

If the striding belt moves to the left, turn the left tension bolt a quarter-turn clockwise and then turn the right tension bolt a quarter-turn counter-clockwise to start the striding belt tracking back to center of roller.

Repeat these adjustments until striding belt appears centered. Allow the belt to continue running for several minutes to be sure that the tracking is stabilized.

NOTE: Do not exceed one full turn of the adjusting screws in either direction. If, after one full turn, the belt does not track properly, contact Customer Support Services. The phone numbers are listed in Section 6.7, titled *How to Obtain Product Service*.

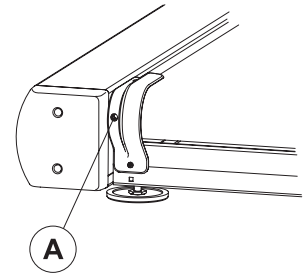

FITNESS NETWORKING

The two interchangeable type RJ45 networking ports (A) are located on the back of the display console. These network ports, located behind the display console rear access door, allow the treadmill to be connected to a fitness entertainment system and/or a fitness network, such as FitLinxx®.

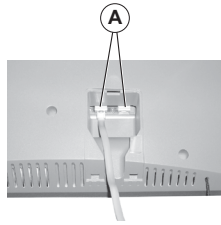

- **Networking:** The built-in networking ports allow the unit to exchange workout information with a fitness network database.
- **Fitness Entertainment:** The network connection enables the console to power a third-party receiver for use with a service such as the Cardio Theater® entertainment system or the BroadcastVision™ entertainment system.

POWER CORD ROUTING

The power cord can be run straight from the treadmill, shortened and exited out the user-front left side, or run under the frame using the power cord clips and exited out the user right-rear side of the treadmill.

For efficient cord management, the following routing options are recommended:

With the power cord unplugged, insert the clips in the appropriate holes. See the illustration below. Use Hole Pattern 1 or 2 to locate the clips and secure the power cord with the clips, taking up any slack between clips.

NOTE: It may be necessary to tip the treadmill to route the power cord properly.

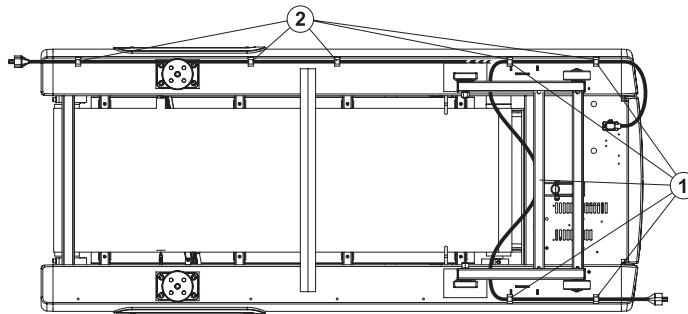

To plug the power cord into an outlet in front of the treadmill, use Hole Pattern 1 for outlets located at the front of the machine.

NOTE: To accommodate treadmill incline, at least two feet (24") of power cord is required between the outlet and the last power cord clip for outlets in front of the treadmill.

To plug the power cord into an outlet in rear of the treadmill, use Hole Pattern 2 for outlets located at the rear of the machine.



WARNING: Make sure that there is a 6-foot clearance behind the treadmill. Contact Life Fitness Customer Service for an optional longer power cord if necessary.



WARNING: Insure that the power cord (A) does not contact the striding belt or get pinched between the frame (C), lift arm (B) or the wheel; failure to follow this warning may result in serious injury.

AVERTISSEMENT : S'assurer que le cordon d'alimentation n'entre pas en contact avec le tapis et ne soit pas pincé entre le cadre, le bras de levage ou la roue. Le non-respect de cet avertissement peut provoquer de graves blessures.

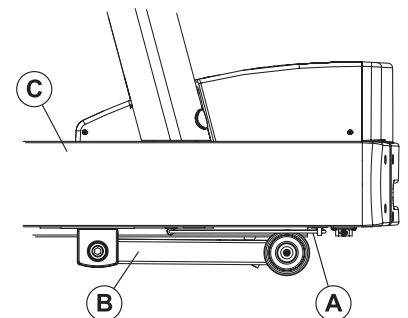

NOTE: When using Pattern 1, it is extremely important to route the power cord BETWEEN the lift frame and the main frame.

2 THE DISPLAY CONSOLE

2.1 DISPLAY CONSOLE OVERVIEW

The computerized display console on the treadmill allows the user to tailor a workout to personal fitness abilities and goals and to monitor progress. With this easy-to-use console, the user can track fitness improvement from one workout to the next.

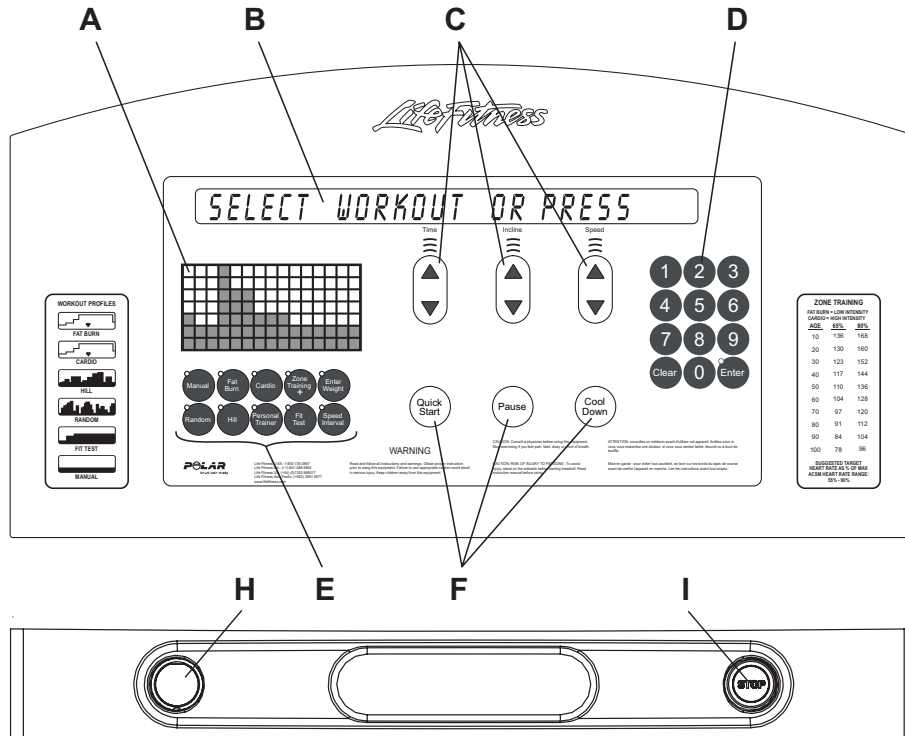

2.2 DISPLAY CONSOLE DESCRIPTION

- A WORKOUT PROFILE WINDOW:** During a workout, interval hills and valleys appear in this window as rows of light stacked in columns. The number of lit rows within a column corresponds to an incline percentage.
- B MESSAGE CENTER:** This window displays step-by-step instructions for setting up a workout. During a workout, it displays calories, distance, time, incline, speed and heart rate. Additionally, the MESSAGE CENTER displays calories per hour, METS, Watts, pace in minutes per mile/kilometer, and distance climbed, if enabled to do so in the Manager's Configuration. See Section 5.1, titled *Entering and Using the Manager's Configuration*.
- C TIME, INCLINE, and SPEED ARROW keys:** Press these keys to increase or decrease the workout time, the incline of the treadmill deck, or the striding belt speed. The MESSAGE CENTER displays the input data in sections located just above the keys. Additionally, any of these keys may be pressed to set up a workout or to change Manager's Configuration settings.
- D NUMERIC keypad:** Use NUMERIC keys to enter exercise time, difficulty level, belt speed, weight, distance, goal selection, gender, and target heart rate.
- CLEAR key:** Press this key once to clear data not yet entered. Press it twice in succession, while programming, to reset the treadmill and restart the programming sequence.
- ENTER key:** Press this key to confirm entries of workout setup values, as displayed in the MESSAGE CENTER.
- E WORKOUT SELECTION keys:** Press any of these keys to select the program identified on the given key's label. These programs include: **FAT BURN**, **CARDIO**, **HILL**, **RANDOM**, **MANUAL**, **ZONE TRAINING +**, **FIT TEST**, **PERSONAL TRAINER**, and **SPEED INTERVAL**.
- ENTER WEIGHT key:** Press this key to enter a user weight during a QUICK START workout. Use the TIME ARROW keys or the NUMERIC keypad to enter a weight value.

F **QUICK START** key: Press this key to begin a manual workout immediately, without having to select a workout program. Once the workout is in progress, use the **ARROW** keys or the **NUMERIC** keypad to change the intensity level or workout duration as desired.

COOL DOWN key: Press this key to begin an automatically customized workout cool-down.

PAUSE key: Press this key to stop the belt and hold the current workout. Continue the workout by pressing the **PAUSE** key a second time or by pressing the **ENTER** key.

H A circular-shaped **STOP** magnet is located on the left side of the panel below the display console. A cord with a clip is attached to this magnet. Before starting a workout, attach the clip to clothing. To stop the striding belt on the treadmill, pull the cord, removing the magnet from the console. Replace the magnet to reset the system.

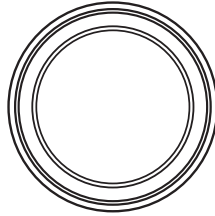

I A circular-shaped **STOP** button is located on the right side of the panel below the display console. Press the button to stop the striding belt and end the current workout.



2.3 READING RACK AND ACCESSORY TRAYS

The display console design includes a built-in reading rack (A) allowing a book or magazine to be supported during the workout. Also included in the display console are three built-in accessory trays (B). Two side trays to accommodate large items such as water bottles and one center tray for smaller items such as personal media devices.

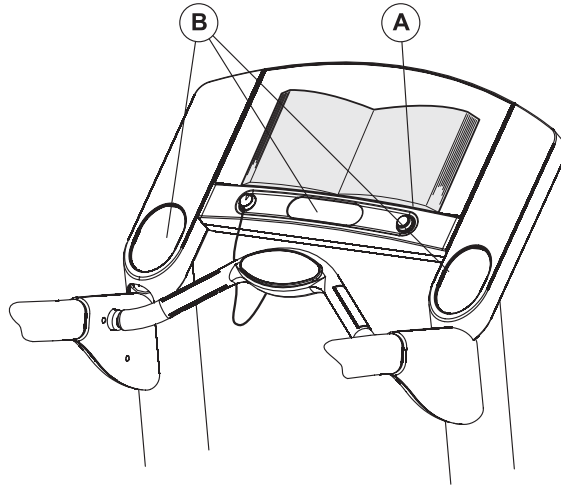

3 HEART RATE ZONE TRAINING® EXERCISE

3.1 WHY HEART RATE ZONE TRAINING® EXERCISE?

Research shows that maintaining a specific heart rate while exercising is the optimal way to monitor the intensity of a workout and to achieve maximum results. That is the idea behind the Life Fitness Heart Rate Zone Training® approach to exercise.

Zone Training identifies an exerciser's ideal heart rate range, or zone, for burning fat or increasing cardiovascular fitness. The zone is a percentage of the theoretical maximum[†] (HRmax), and its value depends on the workout. The Life Fitness Treadmill features five exclusive workouts designed to take full advantage of the benefits of Heart Rate Zone Training+ exercise:

- FAT BURN
- HEART RATE HILL™
- EXTREME HEART RATE™
- CARDIO
- HEART RATE INTERVAL™

Each workout offers different benefits, as discussed in Section 4, titled *The Workouts*.

NOTE: Consulting a fitness trainer is recommended for defining specific fitness goals and designing a workout program.

To change the target heart rate during a workout, simply enter a new target heart rate using the NUMERIC keypad.

To switch between programs during a workout, use the WORKOUT SELECTION keys.

The Heart Rate Zone Training® workout programs measure heart rate. Wear the optional telemetry chest strap, or grip the Lifepulse™ sensors, to enable the treadmill's on-board computer to monitor the heart rate during a workout. The computer automatically adjusts the incline level to maintain the target heart rate based on the actual heart rate.

ZONE TRAINING		
FAT BURN = LOW INTENSITY		
CARDIO = HIGH INTENSITY		
AGE	65%	80%
10	136	168
20	130	160
30	123	152
40	117	144
50	110	136
60	104	128
70	97	120
80	91	112
90	84	104
100	78	96

SUGGESTED TARGET
HEART RATE AS % OF MAX
ACSM HEART RATE RANGE:
55% - 90%

[†] Defined by the American College of Sports Medicine's "Guidelines for Exercise Testing and Prescription" as equal to 220 minus an individual's age.

3.2 HEART RATE MONITORING

THE LIFE PULSE™ SYSTEM

To use the treadmill's Lifepulse™ system to check the heart rate during a workout, grasp the stainless steel sensors on the Ergo™ front handlebar. Two sensors are located on each of the handlebars. Contact must be maintained with all four sensors to obtain a heart rate. The console displays a heart rate within 20 to 30 seconds of contact with the sensors.

Do not attempt to grasp the sensors at speeds above 4.5 MPH, or 7.2 KPH. For these speeds, the use of a heart rate chest strap is recommended.

THE OPTIONAL HEART RATE CHEST STRAP

The Life Fitness Treadmill is equipped with Polar® telemetry, a heart rate monitoring system in which electrodes, pressed against the skin, transfer heart rate signals to the treadmill console. These electrodes are attached to a chest strap that the user wears during the workout. The chest strap is optional. To order it, call Life Fitness Customer Support Services at 1-800-351-3737.

See the diagram below for correct positioning of the strap. The electrodes (A), which are the two grooved surfaces on the underside of the strap, must remain wet to transmit accurately the electrical impulses of the heart back to the receiver. Moisten the electrodes. Then, secure the strap as high under the chest muscles as possible. The strap should be snug, but comfortable enough to allow for normal breathing.

The transmitter strap delivers an optimal heart rate reading when the electrodes are in direct contact with bare skin. However, it functions properly through a thin layer of wet clothing.

If it becomes necessary to re-moisten the chest strap electrodes, grasp the center of the strap, pull it away from the chest to expose the two electrodes, and re-moisten them.

During the setup of a heart rate zone training workout, the user will be required to enter a start-up speed. If a heart rate chest strap is not detected, the maximum allowable speed is 4.5 mph. If a heart rate chest strap is detected, the maximum speed is 14 mph.

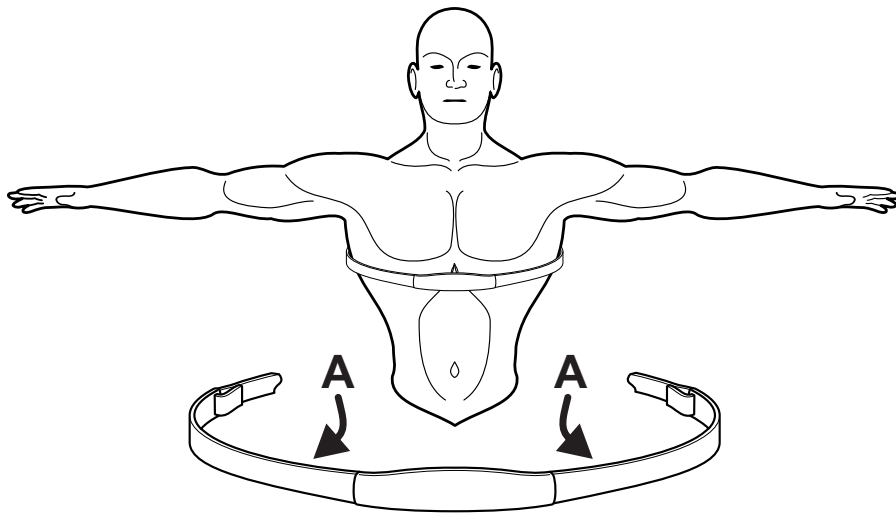

4 THE WORKOUTS

4.1 WORKOUT OVERVIEWS

The following workouts are preprogrammed for the Life Fitness Treadmill.

QUICK START is the fastest way to begin exercising. After the QUICK START key is pressed, a MANUAL workout begins immediately.

MANUAL is a constant effort workout in which the user can change resistance level or speed at any time.

RANDOM is an interval training workout of constantly changing intensity levels that occur in no regular pattern or progression.

HILL is an interval training workout. Intervals are periods of intense aerobic exercise separated by regular periods of lower-intensity exercise.

SPEED INTERVAL enables the user to toggle between two chosen speeds with the touch of a single button.

SPORT TRAINING™ (5K) is a distance-goal workout that simulates an actual terrain with varying incline levels. It is designed to assist runners in training for a 5-kilometer, or 3.1-mile, race. Accessible through the PERSONAL TRAINER workouts button.

SPORT TRAINING™ (10K) is a distance-goal workout that simulates an actual terrain with varying incline levels. It is designed to assist runners in training for a 10-kilometer, or 6.2-mile, race. Accessible through the PERSONAL TRAINER workouts button.

PERSONAL TRAINER workouts are accessed through the PERSONAL TRAINER key. These include the pre-programmed **DISTANCE GOAL**, **CALORIES GOAL**, and **TIME IN ZONE GOAL** workouts, as well as up to six custom workouts, which may be programmed by a fitness club manager or other authorized staff.

HEART RATE HILL™ takes the user through three different hills based on the target heart rate*. The user wears a heart rate chest strap, or grasps the Lifepulse™ sensors continuously.

HEART RATE INTERVAL™ alternates between a hill and a valley based on the target heart rate*. The user wears a heart rate chest strap, or grasps the Lifepulse™ sensors continuously.

EXTREME HEART RATE™ is an intense workout for more experienced users. It is designed to get the heart rate up and down as quickly as possible. The user wears a heart rate chest strap, or grasps the Lifepulse™ sensors continuously.

FAT BURN is a low-intensity workout for burning a higher percentage of calories from fat. The user wears a heart rate chest strap, or grasps the Lifepulse™ sensors continuously. The program adjusts the intensity level through changing the incline (elevation), based on the actual heart rate, to maintain the rate at 65 percent of the theoretical maximum†.

CARDIO is a higher intensity workout for more fit users, maximizing cardiovascular benefits and total calories burned. The user wears a heart rate chest strap, or grasps the Lifepulse™ sensors continuously. The program adjusts the intensity level, based on the actual heart rate, to maintain the rate at 80 percent of the theoretical maximum.

† Defined by the American College of Sports Medicine's "Guidelines for Exercise Testing and Prescription" as equal to 220 minus an individual's age.

* Target Heart Rate (THR) is a percentage of the theoretical maximum (HRmax). A 40-year-old user's recommended THR for the HEART RATE HILL workout is 144, or 80 percent of the maximum; so the equation would be $(220-40) \times 80 = 144$.

FITNESS TESTS

LIFE FITNESS FIT TEST measures cardiovascular fitness and can be used to monitor improvements and endurance every 4-6 weeks.

ADDITIONAL FITNESS TESTS are similar to the FIT TEST workout, except that these programs are based upon specific predefined protocols. The available tests are:

- **ARMY PHYSICAL FITNESS TEST (PFT)** - (U.S. MILITARY)
- **NAVY PHYSICAL READINESS TEST (PRT)** - (U.S. MILITARY)
- **MARINES PHYSICAL FITNESS TEST (PFT)** - (U.S. MILITARY)
- **AIR FORCE FITNESS TEST (PRT)** - (U.S. MILITARY)
- **GERKIN PROTOCOL** - (INTERNATIONAL ASSOCIATION OF FIRE FIGHTERS)
- **PHYSICAL EFFICIENCY BATTERY (PEB)** - (U.S. FEDERAL LAW ENFORCEMENT)

4.2 USING THE WORKOUTS

Select a workout or log on to a fitness network exercise database. See Section 4.5, titled *Logging on to the Network* for details. The chart on the following page lists the steps for setting up each workout.

Use the NUMERIC keypad to enter the values when prompted by the MESSAGE CENTER; or use TIME, INCLINE, or SPEED ARROW keys to scroll to desired values displayed on the MESSAGE CENTER. Press ENTER to confirm each selection. These entered values can be changed during all workouts, except for those found under the **FIT TEST** button.

LIFE FITNESS TREADMILL WORKOUT SETUP STEPS

<p>QUICK START Press QUICK START Begin workout</p> <p>MANUAL Press MANUAL Enter weight Enter time Enter incline Enter speed Begin workout</p> <p>RANDOM Press RANDOM Enter weight Enter time Enter level Enter speed Begin workout</p> <p>FAT BURN** Press FAT BURN Enter weight Enter time Enter age Enter THR* Enter speed Begin workout</p> <p>CARDIO** Press CARDIO Enter weight Enter time Enter age Enter THR* Enter speed Begin workout</p> <p>HILL Press HILL Enter weight Enter time Enter level Enter speed Begin workout</p> <p>PERSONAL TRAINER WORKOUTS Press PERSONAL TRAINER repeatedly until PERSONAL TRAINER WORKOUTS appears; press ENTER Select the desired workout number, from 1 to 6; press ENTER Begin workout</p>	<p>CALORIES GOAL Press PERSONAL TRAINER repeatedly until CALORIES GOAL appears; press ENTER Enter weight Enter calories Enter incline Enter speed Begin workout</p> <p>DISTANCE GOAL Press PERSONAL TRAINER repeatedly until DISTANCE GOAL appears; press ENTER Enter weight Enter distance Enter incline Enter speed Begin workout</p> <p>TIME IN ZONE GOAL Press PERSONAL TRAINER repeatedly until TIME IN ZONE GOAL appears; press ENTER Enter weight Enter time Select Fat Burn or Cardio Enter age Enter THR* Enter speed Begin workout</p> <p>SPORT TRAINING™ Press PERSONAL TRAINER repeatedly until SPORT TRAINING 5K or SPORT TRAINING 10K appears; press ENTER Enter weight Enter level Enter speed Begin workout</p> <p>HEART RATE HILL™** Press ZONE TRAINING+ repeatedly until HR HILL appears; press ENTER Enter weight Enter time Enter age Enter THR* Enter speed Begin workout</p>	<p>HEART RATE INTERVAL™** Press ZONE TRAINING+ repeatedly until HR INTERVAL appears; press ENTER Enter weight Enter time Enter age Enter THR* Enter speed Begin workout</p> <p>EXTREME HEART RATE™** Press ZONE TRAINING+ repeatedly until EXTREME HR appears; press ENTER Enter weight Enter time Enter age Enter THR* Enter walk speed Enter jog speed Begin workout</p> <p>LIFE FITNESS FIT TEST** Press FIT TEST repeatedly until FIT TEST appears; press ENTER Enter weight Enter age Enter gender Enter speed Begin workout</p> <p>ARMY PFT Press FIT TEST repeatedly until ARMY PFT appears; press ENTER Enter weight Enter age Enter gender Enter speed Begin workout</p> <p>NAVY PRT Press FIT TEST repeatedly until NAVY PRT appears; press ENTER Enter YES or NO to question: ELEVATION LESS THAN 5000 FEET ABOVE SEA LEVEL? Enter weight Enter age Enter gender Enter speed Begin workout</p>	<p>MARINES PFT Press FIT TEST repeatedly until MARINES PFT appears; press ENTER Enter YES or NO to question: ELEVATION LESS THAN 4500 FEET ABOVE SEA LEVEL? Enter weight Enter gender Enter speed Begin workout</p> <p>AIR FORCE PFT Press FIT TEST repeatedly until AIR FORCE PRT appears; press ENTER Enter weight Enter age Enter gender Enter speed Begin workout</p> <p>GERKIN PROTOCOL** Press FIT TEST repeatedly until GERKIN PROTOCOL appears; press ENTER Enter weight Enter age Enter THR* Begin workout</p> <p>PEB TEST Press FIT TEST repeatedly until PEB TEST appears; press ENTER Enter weight Enter age Enter gender Enter speed Begin workout</p> <p>SPEED INTERVAL Press SPEED INTERVAL Enter weight Enter time Enter incline Enter jog speed Enter run speed</p>
--	--	--	---

* Target Heart Rate (THR) is a percentage of the theoretical maximum (HRmax). For example, a 40-year-old user's recommended THR for the FAT BURN workout is 117. The FAT BURN workout targets 65 percent of the maximum, so the equation would be $(220-40) \times .65 = 117$.

** This workout requires the user to wear the telemetry chest strap or grasp the Lifepulse™ sensors.

4.3 WORKOUT DESCRIPTIONS

QUICK START

QUICK START is the fastest way to begin exercising. After the QUICK START key is pressed, a MANUAL workout begins. For accurate caloric expenditure, enter weight using the ENTER WEIGHT button. The incline level is set to zero by default. Change the level using the INCLINE ARROW key. Change the speed using the SPEED key, up or down as desired, or use the NUMERIC keypad to enter a new speed value.

MANUAL

The **MANUAL** program is a constant effort workout in which the user can change resistance level or speed at any time.

RANDOM

The **RANDOM** program creates a terrain of hills and valleys that varies with each workout. More than one million different patterns are possible.

FAT BURN

The **FAT BURN** workout is designed to maintain a user's heart rate at 65 percent of the theoretical maximum[†] (HRmax) for optimal results. Throughout the workout, the user wears a chest strap or grasps the Lifepulse™ sensors. If the user is not wearing a chest strap, the WORKOUT PROFILE WINDOW displays a heart shape, and the MESSAGE CENTER displays a prompt to grasp the sensors. The console continuously monitors and displays the heart rate, adjusting the intensity level of the treadmill to reach and maintain the target*. This system eliminates over- and under-training, and it maximizes the aerobic benefits of exercise by using the body's fat stores for fuel.

NOTE: *The intensity level is changed by incline. Speed can only be changed by the user.*

CARDIO

The **CARDIO** workout is virtually identical to **FAT BURN**; however the target heart rate is calculated at 80 percent of the theoretical maximum[†] (HRmax)**. The higher target promotes cardiovascular improvement by placing a heavier workload on the heart muscle.

NOTE: *The intensity level is changed by incline. Speed can only be changed by the user.*

NOTE: *Change the target heart rate at any time by using the NUMERIC KEYPAD.*

[†] Defined by the American College of Sports Medicine's "Guidelines for Exercise Testing and Prescription" as equal to 220 minus an individual's age.

* Target Heart Rate (THR) is a percentage of the theoretical maximum (HRmax). For example, a 40-year-old user's recommended THR for the FAT BURN workout is 117, or 65 percent of the maximum, so the equation would be $(220-40) \cdot 65 = 117$.

** Target Heart Rate (THR) is a percentage of the theoretical maximum (HRmax). A 40-year-old user's recommended THR for the CARDIO workout is 144, or 80 percent of the maximum; so the equation would be $(220-40) \cdot 80 = 144$.

HILL

The Life Fitness-patented **HILL** workout offers a variety of configurations for interval training. Intervals are periods of intense cardiovascular exercise separated by regular periods of lower-intensity exercise. The **WORKOUT PROFILE** window represents these high and low intervals as columns of illuminated LEDs, which together have the appearance of hills and valleys. The computerized interval training workout has been scientifically demonstrated to promote greater cardiorespiratory improvement than steady-pace training.

The **HILL** workout goes through four phases, each marked by different intensity levels. The **WORKOUT PROFILE** window displays the progress of these phases. As noted in the descriptions below, the heart rate should be measured at two stages in the workout to gauge its effectiveness. Wear the chest strap or continuously grip the Lifepulse™ handles. The **MESSAGE CENTER** does not display a request for a heart rate measurement, as it does with **CARDIO**, **FAT BURN** and the **HEART RATE ZONE TRAINING** programs.

- 1 Warm-up** is a phase of low, gradually rising resistance, which brings the heart rate into the lower end of the target zone and increases respiration and blood flow to working muscles.
- 2 Plateau** increases the intensity slightly, and keeps it steady, to bring the heart rate to the low end of the target zone. Check the heart rate at the end of this phase.
- 3 Interval Training** is a series of increasingly steeper hills, alternating with valleys, or stints of recovery. The heart rate should rise to the high end of the target zone. Check the heart rate at the end of this phase.
- 4 Cool-down** is a low-intensity phase that allows the body to begin removing lactic acid, and other exercise by-products, which build up in muscles and contribute to soreness.

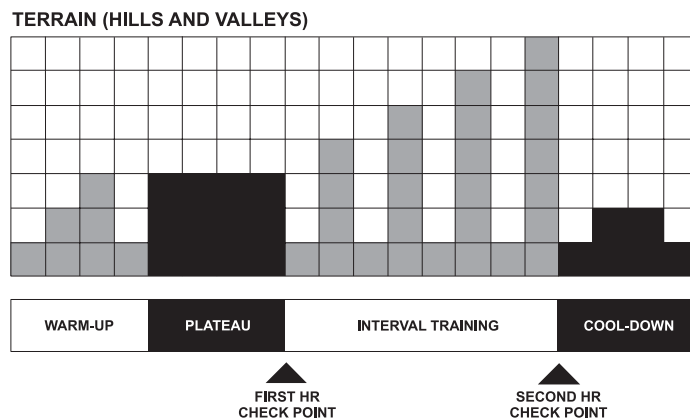

Each column, as seen in the **WORKOUT PROFILE WINDOW** and the chart above, represents one interval. The overall duration of the workout determines the length of each interval. Each workout is made up of 20 intervals, so the duration of each interval is equal to the duration of the entire workout divided by 20.

1 to 9 minutes: A workout with a duration of less than 10 minutes is insufficient for the **HILL** program to complete all four phases adequately. The program, therefore, condenses a workout of this duration at various stages.

10 to 19 minutes: The interval durations initially are set at 30 seconds for a 10-minute workout. For every minute over 10, each interval increases by three seconds. A 15-minute workout consists of 20 intervals at 45 seconds each.

20 to 99 minutes: All intervals last 60 seconds. If the user adds minutes to the pre-set duration while the workout is in progress, the program adds hills and valleys that are identical to the first eight intervals of the Interval Training phase. This pattern repeats until the workout is completed.

CUSTOM WORKOUTS

The treadmill console stores up to six custom workouts. These workouts are created by fitness club managers or other authorized personnel. For information on creating these workouts, see the topic titled *Programming Custom Workouts* in Section 5, titled *The Manager's Configuration*.

To use custom workouts, press the PERSONAL TRAINER button repeatedly until the MESSAGE CENTER displays "PERSONAL TRAINER WORKOUTS". Then, press ENTER. The MESSAGE CENTER displays a prompt to select a custom workout number, ranging from 1 to 6. Using the ARROW keys or the NUMERIC keypad, select the number and press ENTER. If a workout has not been created for that number, the MESSAGE CENTER simply scrolls to the next number. If a workout has been created for the selected number, the MESSAGE CENTER displays successive prompts to enter the weight and choose a speed. After these entries are provided, the workout begins.

CALORIES GOAL

This workout is designed to promote weight loss and weight control. The objective is to burn a certain number of calories in the selected time duration. Once the objective is met, the workout automatically goes into a cool-down phase, and ends afterward.

DISTANCE GOAL

This workout is designed to build endurance. The objective is to cover a certain distance in miles. Once the objective is met, the workout automatically goes into a cool-down phase, and ends afterward.

NOTE: When a user sets this goal with the TIME ARROW keys, the console displays the values in .10-mile increments.

TIME IN ZONE GOAL

The Time in Zone Goal program, a feature of Heart Rate Zone Training®, enhances **FAT BURN** and **CARDIO** workouts by setting a duration for staying within the target zone as the workout goal. Once the duration objective is met, the workout goes into a cool-down phase.

SPORT TRAINING™

This distance-goal workout is designed for runners training for races. The program creates realistic terrains by setting different incline levels throughout the course. Incline grades depend on the difficulty levels selected during the workout setup. A 1.5 percent incline grade, which is the baseline level, simulates a flat running surface. A zero percent grade simulates running downhill. Incline durations range between 30 and 60 seconds. The course ends when the distance goal is met.

Two Sport Training™ programs are available on the treadmill:

- **SPORT TRAINING™ (5K)** is a 5-kilometer, or 3.1-mile, course.
- **SPORT TRAINING™ (10K)** is a 10-kilometer, or 6.2-mile, course.

HEART RATE HILL™

This program combines the standard **HILL** workout profile with the concept of Heart Rate Zone Training. The default target heart rate* is calculated as 80 percent of the theoretical maximum† (HRmax), but the user can adjust the target rate during the workout setup. All hills and valleys are percentages of HRmax. The workout consists of three hills that target three heart rate goals: The first hill brings the heart rate to 70 percent of HRmax. The second hill increases the rate to 75 percent of HRmax. The third hill matches the Target Heart Rate bringing the heart rate to 80 percent of HRmax. The valley always is defined as 65 percent of HRmax.

After a standard three-minute warm-up, the workout progresses toward the first hill and heart rate goal. Once the user reaches 70 percent of HRmax, the hill continues for one minute. When the minute expires, the level decreases into a valley. Once the user's heart rate falls to 65 percent of HRmax, the valley continues for one minute. Then, the next hill begins with its corresponding heart rate goal. After the user completes the third hill/valley pair, the program returns to the first hill and repeats the cycle as long as the duration allows. At the end of the duration, the workout goes into a cool-down phase. If the heart rate goes above the theoretical maximum for more than 45 seconds, the treadmill automatically goes into pause mode. If the user does not reach a heart rate goal after five minutes, the MESSAGE CENTER displays a prompt to increase or decrease speed, depending on whether the workout is in a hill or valley phase. The program does not proceed to a new heart rate goal until the user reaches the current goal.

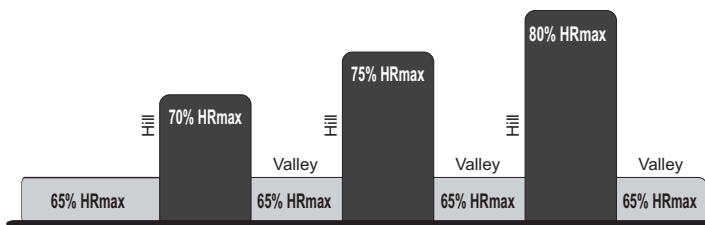

HEART RATE HILL Workout Profile

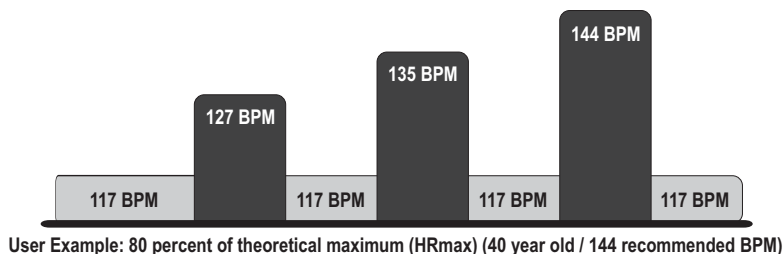

† Defined by the American College of Sports Medicine's "Guidelines for Exercise Testing and Prescription" as equal to 220 minus an individual's age.

* Target Heart Rate (THR) is a percentage of the theoretical maximum (HRmax). A 40-year-old user's recommended THR for the HEART RATE HILL workout is 144, or 80 percent of the maximum; so the equation would be $(220-40) \cdot 80 = 144$.

HEART RATE INTERVAL™

This program also combines the standard **HILL** workout profile with the concept of Heart Rate Zone Training. The default target heart rate* is calculated as 80 percent of the theoretical maximum† (HRmax), but the user can adjust the target rate during the workout setup. The workout alternates between a hill, which brings the heart rate up to the target rate of 80 percent of HRmax, and a valley, which brings the heart rate down to 65 percent of HRmax. After a standard three-minute warm-up, the workout progresses toward the first hill and heart rate goal. Once the goal is reached, the hill continues for three minutes. Then, the level decreases into a valley. Once the 65 percent of HRmax goal is reached, the valley continues for three minutes, after which the next hill begins. The user's fitness level determines the number of hills and valleys encountered within the duration. At the end of the duration, the workout goes into a cool-down phase. If the heart rate goes above the theoretical maximum† for more than 45 seconds, the treadmill automatically goes into pause mode. If the user does not reach a heart rate goal after five minutes, the MESSAGE CENTER displays a prompt to increase or decrease speed, depending on whether the workout is in a hill or valley phase. The program does not proceed to a new heart rate goal until the user reaches the current goal.

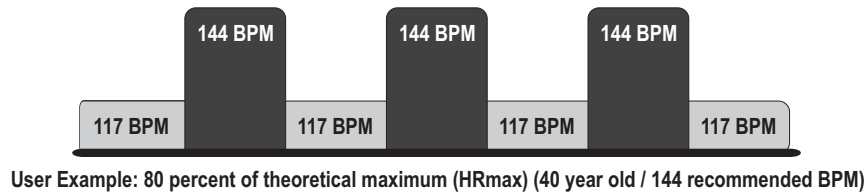
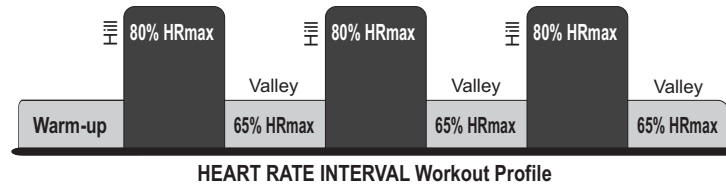

† Defined by the American College of Sports Medicine's "Guidelines for Exercise Testing and Prescription" as equal to 220 minus an individual's age.

* Target Heart Rate (THR) is a percentage of the theoretical maximum (HRmax). A 40-year-old user's recommended THR for the HEART RATE INTERVAL workout is 144, or 80 percent of the maximum; so the equation would be $(220-40) \cdot 80 = 144$.

EXTREME HEART RATE™

This intense, varied workout is designed to help more experienced users to break through fitness improvement plateaus. The workout alternates between two target heart rates* as quickly as possible. The effect is similar to that of running sprints. The user must wear a chest strap or grip the Lifepulse™ sensors throughout the workout.

NOTE: It is recommended that users who run at speeds faster than 4.5 MPH wear the chest strap and do not use the Lifepulse™ sensors.

When setting up the workout, the user enters a target heart rate and selects a walk speed and a jog speed. After a standard three-minute warm-up, the treadmill accelerates to the jog speed, and the incline increases, until the user reaches the target heart rate goal of 85 percent of the theoretical maximum† (HRmax). That target rate is maintained for a stabilizing period. Then, the incline is reduced to 0 percent, and the treadmill slows to the walk speed. When the heart rate falls to the 65 percent of HRmax goal, it is maintained there for a stabilizing period. The program repeats the alternating of speeds and incline levels, continuing this pattern throughout the duration.

If the user does not reach a heart rate goal after five minutes, the MESSAGE CENTER displays a prompt to increase or decrease speed, depending on whether the workout is in a hill or valley phase. The program does not proceed to a new heart rate goal until the user reaches the current goal.

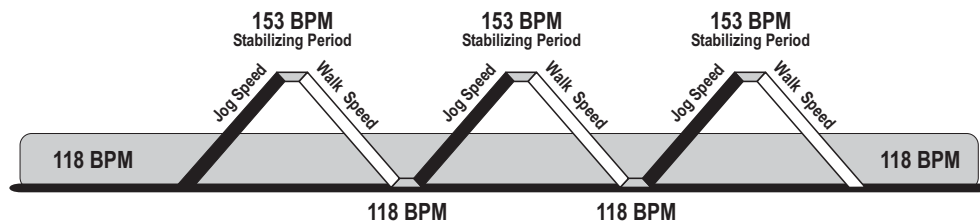
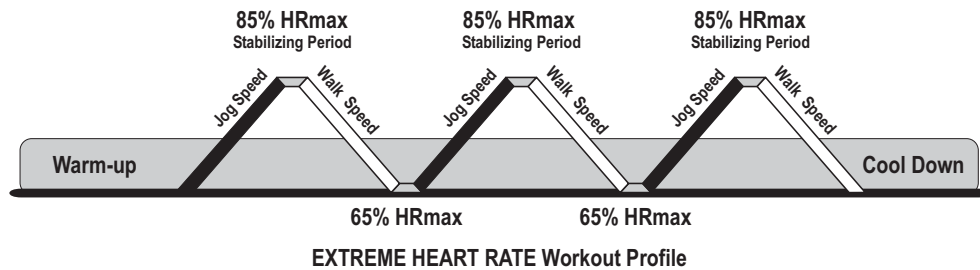

User Example 85 percent of theoretical maximum (HRmax) (40 year old / 153 recommended BPM)

† Defined by the American College of Sports Medicine's "Guidelines for Exercise Testing and Prescription" as equal to 220 minus an individual's age.

* Target Heart Rate (THR) is a percentage of the theoretical maximum (HRmax). For example, a 40-year-old user's recommended THR for the EXTREME HEART RATE™ WORKOUT is 153. The workout program targets a standard 85 percent of the maximum, so the equation would be $(220 - 40) \times 0.85 = 153$.

FIT TEST

The treadmill Fit Test program is another exclusive feature of this versatile treadmill. The Fit Test workout estimates cardiovascular fitness and can be used to monitor improvements in endurance every four to six weeks. The user must grasp the hand sensors (if equipped) when prompted or wear a heart rate chest strap, as the test score calculation is based on a heart rate reading. The workout duration will be five minutes at a 5% incline. Immediately afterward, the console will take the user's heart rate reading, calculate a fitness score, and display the score in the MESSAGE CENTER.

The Fit Test is considered to be a submax VO₂ (volume of oxygen) test. It gauges how well the heart supplies oxygenated blood to the exercising muscles, and how efficiently those muscles receive oxygen from the blood. Physicians and exercise physiologists generally regard this test as a good measure of aerobic capacity.

To set up the Fit Test:

- Press the FIT TEST button repeatedly until the FIT TEST option appears in the message center. Press ENTER to select the FIT TEST option.
- The message center will prompt for a user weight (ENTER WEIGHT). Use the NUMERIC KEYS or UP/DOWN ARROW KEYS to input your weight. Press ENTER to accept the weight.
- The message center will next prompt for a user age (ENTER AGE). Use the NUMERIC KEYS or UP/DOWN ARROW KEYS to input your age. Press ENTER to accept the age.
- The message center will next prompt for a user gender (SELECT GENDER). Using the UP/DOWN ARROW KEYS, select a gender. Press ENTER to accept the gender selection.
- The message center will next prompt for a workout level (ENTER SPEED)(2-4.5 mph). Consult the following recommended fit test level chart for an appropriate effort level based on your age, gender and activity level. Use the NUMERIC KEYS or UP/DOWN SPEED ARROW KEYS to enter the corresponding level.

After the five-minute FIT TEST is completed, a FIT TEST score will be displayed.

FIT TEST PROGRAM SUGGESTED EXERTION LEVELS

	Inactive	Active	Very Active
Treadmill Fit Test Level	2-3 mph	3-4 mph	3.5-4.5 mph
	3.2-4.8 kph	4.8-6.4 kph	5.6-7.2 kph

NOTE: Treadmill will incline to 5% after a one minute warm-up.

Suggested exertion levels should be used as a guideline for setting up the Fit Test program. The goal is to elevate the user's heart rate to a level that is between 60%-85% of their theoretical maximum heart rate (220-age).

Within each suggested range, these additional guidelines can be used:

Lower Half of Range	Upper Half of Range
higher age	lower age
lower weight	higher weight*
shorter	taller

* In cases of excessive weight, use lower half of range

The computer will not accept:

- heart rates less than 52 or greater than 200 beats per minute
- body weights less than 75 pounds (34 kg) or greater than 400 pounds (181 kg)
- ages below 10 or over 99 years
- data input that exceeds human potential

If you make an error when entering any Fit Test data, you can correct it by pressing CLEAR, inputting the correct information, and pressing ENTER.

It is important for you to take the Fit Test under similar circumstances each time. Your heart rate is dependent on many factors, including:

- amount of sleep the previous night (at least seven hours is recommended)
- time of day
- time you last ate (two to four hours after the last meal is recommended)
- time since you last drank a liquid containing caffeine or alcohol, or smoked a cigarette (at least four hours is recommended)
- time since you last exercised (at least six hours is recommended)

For the most accurate Fit Test results, you should perform the Fit Test on three consecutive days and average the three scores.

NOTE: To receive a proper Fit Test score, the work done must be within a training heart rate zone that is 60 percent to 85 percent of the theoretical maximum heart rate (HRmax). This rate is defined by the American College of Sports Medicine's "Guidelines for Exercise Testing and Prescription" as equal to 220 minus an individual's age.

The tables below list fit test results.

RELATIVE FITNESS CLASSIFICATION FOR MEN

Men	Estimated VO2 Max (ml/kg/min) Per Age Category				
	20-29	30-39	40-49	50-59	60+
Elite	52+	51+	48+	45+	42+
Excellent	50-51	48-50	46-47	42-44	39-41
Very Good	47-49	45-47	43-45	40-41	36-38
Above Average	44-46	42-44	40-42	37-39	33-35
Average	41-43	39-41	37-39	34-36	30-32
Below Average	38-40	36-38	34-36	31-33	27-29
Low	35-37	33-35	31-33	28-30	24-26
Very Low	<35	<33	<31	<28	<24

RELATIVE FITNESS CLASSIFICATION FOR WOMEN

Women	Estimated VO2 Max (ml/kg/min) Per Age Category				
	20-29	30-39	40-49	50-59	60+
Elite	44+	42+	39+	35+	34+
Excellent	42-43	40-41	37-38	33-34	32-33
Very Good	39-41	37-39	35-36	31-32	30-31
Above Average	37-38	35-36	32-34	29-30	28-29
Average	34-36	32-34	30-31	27-28	25-27
Below Average	31-33	29-31	27-29	25-26	23-24
Low	28-30	27-28	25-26	22-24	20-22
Very Low	<28	<27	<25	<22	<20

Life Fitness developed this rating scale based on VO2 max percentile distributions referenced in *American College of Sports Medicine's "Guidelines for Exercise Testing and Prescription"* (6th Ed. 2000). It is designed to provide a qualitative description of a user's VO2 max estimation, and a means of assessing initial fitness level and tracking improvement.

FITNESS TESTS

The Life Fitness Treadmill features fitness tests based upon specific predefined protocols.

- **ARMY PFT:** 2.0 miles
The U.S. Army Physical Fitness Test is a physical performance test used to assess muscular endurance and cardiorespiratory fitness.
- **NAVY PRT:** 1.5 miles
The running portion of the U.S. Navy Physical Readiness Test is a distance goal test based on the time needed to complete the required distance and is used by the U.S. Navy and Naval academies to measure aerobic capacity.
- **MARINES PFT:** 3.0 miles
The U.S. Marines Physical Fitness Test is a physical performance test used to assess muscular endurance and cardiorespiratory fitness.
- **AIR FORCE PRT:** 1.5 miles
The U.S. Air Force Physical Readiness Test is a physical performance test used to assess muscular endurance and cardiorespiratory fitness.
- **GERKIN:** Submaximal VO₂
The Gerkin Protocol is a graded submaximal VO₂ test used by the International Association of Fire Fighters to determine fitness for fire department duty.
- **PHYSICAL EFFICIENCY BATTERY:** 1.5 miles
The Physical Efficiency Battery is used by U.S. Federal Law Enforcement, U.S. Federal Bureau of Investigation, and other federal organizations for the hiring and maintenance of federal jobs.

Scores for these tests are based on finishing time, age, and gender.

To set up one of these tests, press the FIT TEST key repeatedly, until the MESSAGE CENTER displays the name of the desired test. Then, press ENTER. If the selected test is either the **NAVY** or **MARINES** test, the MESSAGE CENTER displays a question as to whether the test is taking place below a certain altitude. For the **NAVY** test, the altitude is 5,000 feet above sea level; and for the **MARINES** test, the altitude is 4,500 feet above sea level. Using the ARROW KEYS, select the answer "ABOVE 5,000 FEET"(**NAVY**) / "ABOVE 4,500 FEET"(**MARINES**) or "BELOW 5,000 FEET"(**NAVY**) / "BELOW 4,500 FEET"(**MARINES**) by toggling between these words displayed in the MESSAGE CENTER. Press Enter.

At the MESSAGE CENTER prompts, enter the weight, age, gender, and desired speed, using the ARROW keys or the NUMERIC keypad. Press ENTER after each entry. Then, begin the workout. To ensure an accurate test score, do not change these entries once the workout begins.

For all FITNESS TESTS except **GERKIN**, after the distance goal is reached, the workout program goes into a cool-down. The duration of this phase depends on the amount of time taken to complete the test. For less than five minutes, the cool-down is one minute. For five to 15 minutes, the cool-down is three minutes. For longer times, the cool-down is five minutes. The user can abort the cool-down by pressing the STOP button or the CLEAR key. After the cool-down is aborted or completed, the MESSAGE CENTER displays the finishing time and a point score for the PEB, Army, and Marines tests; or a qualitative score, such as EXCELLENT, for the Navy test.

For the Gerkin test, the time at which the heart rate reached the target heart rate and is maintained for 15 seconds, and a converted VO₂ MAX value will be shown in the MESSAGE CENTER during the workout summary.

SPEED INTERVAL

This program allows the user to toggle between user defined JOG and RUN speeds. The SPEED INTERVAL button will flash throughout the workout. The user can toggle the speeds at any time during the workout by pressing the speed interval button. The current speed will appear in the speed display window.

The preset JOG and RUN speeds cannot be changed during a workout. The speed can be adjusted at any time during a workout using the SPEED ARROW keys. Toggling the JOG and RUN speeds using the SPEED INTERVAL button will reset the speeds to the preset JOG and RUN speeds.

4.4 MAXIMIZING WORKOUTS ON A LIFE FITNESS TREADMILL

SELECTING A LEVEL

The steps for setting up a **HILL**, **RANDOM**, **SPORT TRAINING 5K**, and **SPORT TRAINING 10K** workout include selecting a level. The word “level” refers to a range of incline percentages. The treadmill features 20 levels, with Level 1 having the lowest average incline grade and Level 20 having the highest.

LEVEL	% Incline	LEVEL	% Incline
1	0.0 - 1.5	11	2.0 - 8.5
2	0.0 - 2.2	12	3.0 - 9.2
3	0.0 - 2.9	13	3.5 - 9.9
4	0.0 - 3.6	14	5.0 - 10.6
5	0.0 - 4.3	15	5.5 - 11.3
6	0.0 - 5.0	16	6.5 - 12.0
7	0.0 - 5.7	17	7.0 - 12.7
8	0.0 - 6.4	18	8.0 - 13.4
9	0.5 - 7.1	19	8.7 - 14.1
10	1.5 - 7.8	20	9.0 - 15.0

Within each level are seven incline percentages, or hills. During a workout, each hill appears in the **WORKOUT PROFILE** window as rows of light stacked in a column. The number of lit rows within a column corresponds to an incline percentage. For example, in Level 5, the lowest incline is 0.0 percent and is represented as one lit row. The highest incline, 4.3 percent, is represented by a column with all seven rows lit.

In the **HILL** and **RANDOM** workouts, these varying hills occur for equal durations, as discussed in the **HILL** workout description. When the workout program brings up a new hill, the incline percentage changes automatically to match that hill. To change levels during a workout, use the **ARROW** keys or the **NUMERIC** keypad.

USING INSTAPACE™ FEEDBACK

The InstaPace™ Feedback feature enables users to monitor their pace, or rate of minutes per mile, while running on the treadmill. This feature must be enabled in the Manager’s Configuration. See Section 5, titled *The Manager’s Configuration*, for more information. The **MESSAGE CENTER** displays the **MPH** and **pace** simultaneously when the user adjusts the treadmill speed with the **ARROW KEYS**. If the user adjusts the speed using the **NUMERIC** keypad, the **MESSAGE CENTER** displays the **pace** after the treadmill reaches the new speed.

USING ZEROOUT™ SPEED CONTROL

If, during a workout, a user decreases the speed to the minimum and continues to hold the **DECREASE SPEED ARROW**, the speed falls to 0 **MPH**, which is **pause mode**. The minimum speed is 0.5 **MPH**, unless changed in the Manager’s Configuration. See section 5.2, titled *Configuration Settings*, for more information.

COOL-DOWN

Life Fitness' unique Cool-Down Protocol automatically customizes every cool-down based on each user's workout performance. Workout performance factors, such as speed, incline, duration, and heart rate, determine the duration and intensity of the cool-down.

DIMMING

The dimming feature controls the brightness of the treadmill console display. To change the default brightness setting, press the PERSONAL TRAINER button repeatedly until the MESSAGE CENTER displays "DIMMING," and press ENTER. Then, use the ARROW keys to increase or decrease the brightness to the desired setting, and press ENTER to save the new setting; or press CLEAR to revert to the default brightness setting.

If a new brightness setting is selected for a workout, that setting remains in place until it is manually changed, or the workout concludes. When a new workout begins, the brightness reverts to the default setting.

4.5 LOGGING ON TO THE NETWORK

When the treadmill is connected to a network, the MESSAGE CENTER displays a prompt to log on with a personal ID number. Press ENTER. Then, using the NUMERIC KEYPAD, enter the correct digits of the ID number, and press ENTER again. Refer to Section 5.1 "*Using Quick Start Disable*" for detailed information regarding network configuration options.

5 THE MANAGER'S CONFIGURATION

5.1 ENTERING AND USING THE MANAGER'S CONFIGURATION

To enter the Manager's Configuration, press and hold down the PAUSE key and press the CLEAR key twice. Continue to hold down the PAUSE key until the MESSAGE CENTER displays the words "SERVICE MENU". Then, release the PAUSE key, press the QUICK START key, and press ENTER. The MESSAGE CENTER then displays, in turn, each of the configuration settings.

Use the TIME arrow keys to scroll through the list of settings, or allow the MESSAGE CENTER to scroll automatically through the options. To stop the automatic scrolling, press the PAUSE key. To resume the automatic scrolling, press the PAUSE key again. To select a displayed option, press the ENTER key.

The Manager's Configuration settings are listed on the following page in the order in which they appear in the MESSAGE CENTER display. Use the INCLINE or SPEED keys to change settings. In most cases, changing a setting means turning it on or off. See the table on the following page for more information.

5.2 CONFIGURATION SETTINGS

CONFIGURATION SETTING	FACTORY DEFAULT	DESCRIPTION
LANGUAGE	ENGLISH	The language of the MESSAGE CENTER display. Choices include English, German, French, Italian, Dutch, Spanish, Portuguese, and Turkish. Japanese available on units equipped with the Complex Character Display (CCD) only.
MAX DURATION SETUP	60 Minutes	This feature enables fitness club managers to set workout duration limits.
ENGLISH/METRIC UNITS	ENGLISH	The measurement unit type for weight, distance, and speed.
CUSTOM WORKOUT ENTRY	N/A	See <i>Programming Custom Workouts</i> in Section 4.
TELEMETRY	ON	Switching on the telemetry feature makes it possible to use the Polar®-compatible Heart Rate Zone Training exercise chest strap for monitoring the heart rate.
MAXIMUM SPEED	14.0 (MPH)	This is the fastest speed at which the treadmill can operate.
MINIMUM SPEED	0.5 (MPH)	This is the slowest speed at which the treadmill can operate.
PAUSE TIMEOUT	1 (minute)	This is the maximum time during which a workout can remain in pause mode.
WATTS DISPLAY	OFF (Int'l: ON)	If this option is enabled, the MESSAGE CENTER displays the Watts equivalent of the step rate.
METS DISPLAY	OFF	If this option is enabled, the MESSAGE CENTER displays the METs equivalent of the step rate.
PACE DISPLAY	ON	This feature displays the rate of minutes per mile.
CALORIE PER HOUR DISPLAY	ON (Int'l: OFF)	If this option is enabled, the MESSAGE CENTER displays the number of calories burned per hour during the workout.
DISTANCE CLIMBED DISPLAY	OFF	The total distance climbed, based on the incline and speed of the treadmill.
ACCELERATION RATE	3	The rate at which the treadmill accelerates to the selected speed, ranging from 1 (slowest) to 5 (fastest).
DECELERATION RATE	3	The rate at which the treadmill decelerates to the selected speed, ranging from 1 (slowest) to 5 (fastest).
ERASE CUSTOM WORKOUTS	N/A	This option erases all custom workouts in a single step.
MAXIMUM INCLINE	15.0	This option changes the maximum incline grade to a value lower than 15 percent.
START MESSAGE SETUP	N/A	See "Using the START MESSAGE Setup" in this section.
QUICK START DISABLE	OFF	Use this option to disable or enable QUICK START workouts via the numeric keys. See "Using QUICK START Disable" in this section.
FIT TEST PLUS	ON (Int'l: OFF)	Enable/Disable Fit Tests: Army PFT; Navy PRT; Marines PFT; Gerkin protocol; PEB
SYSTEM BEEPS	ON	Enable/Disable system beep on key press.
USER LANGUAGE SELECT	OFF	This option, if enabled, gives users the ability to select a language for use during a workout. See the topic titled <i>User Language Select</i> in this section.
MARATHON MODE	OFF	This option, if enabled, allows the user to workout indefinitely. See the topic titled <i>Marathon Mode</i> in this section.
BELT NOTIFICATION LIGHT	OFF	IF ENABLED, This option will alert a fitness club manager if a belt notification exists.

PROGRAMMING CUSTOM WORKOUTS

After entering the Manager's Configuration, use the TIME ARROW keys to scroll through the list of configuration options, or allow the MESSAGE CENTER to scroll automatically through the options. When "CUSTOM WORKOUT ENTRY" appears, press ENTER to select this option.

The custom workouts are identified as numbers, from 1 to 6. Enter the desired number on the NUMERIC keypad, or use the ARROW keys to scroll through the displayed numbers. Press ENTER to confirm the number selection. If a workout does not already exist for that number, the MESSAGE CENTER displays a request to begin creating the workout.

If a workout does exist for the number in question, the MESSAGE CENTER displays a statement to that effect, followed by the option to modify the existing workout. The steps for modifying a workout are the same as those for creating a new workout:

Using the TIME ARROW keys or the NUMERIC keypad, select a workout duration time in minutes, and press ENTER. The duration cannot exceed the MAX DURATION set in the Manager's Configuration.

Next, select the interval type. Use the arrow keys to toggle between the displayed options, and press the ENTER key to select the desired interval type. Options are:

- Speed/Incline, in which a treadmill speed and/or incline grade is selected for each interval.
- Target Heart Rate, in which a maximum target heart rate is selected for each interval.

The number of intervals is always 30, so the length of each interval equals the selected duration divided by 30. Each interval is identified by the time at which it occurs during the workout.

If Speed/Incline is selected, the MESSAGE CENTER displays each interval, identified as the time at which the interval occurs. For each displayed interval, enter a speed using the SPEED ARROW keys, and/or enter an incline grade using the INCLINE ARROW keys. Press Enter to confirm each selection. After values are selected for all 30 intervals, the MESSAGE CENTER displays the statement, "CUSTOM WORKOUT COMPLETED", followed by a prompt to create a workout for the next number.

If Target Heart Rate is selected, the MESSAGE CENTER displays each interval, identified as a numeral from 1 to 30. For each displayed interval, enter a target heart rate using the ARROW keys. Press Enter to confirm each selection. After values are selected for all 30 intervals, the MESSAGE CENTER displays the statement, "CUSTOM WORKOUT COMPLETED", followed by a prompt to create a workout for the next number.

USING QUICK START DISABLE

This configuration has two possible values which are selected using the incline arrow keys.

The values are as follows:

- Quick Start with numeric keys "**allowed**"
- Quick Start with numeric keys "**not allowed**"

The default value is "allowed". This means that a user can start a QUICK START workout by simply entering a desired workout speed using the numeric keys only. If the configuration is set to "not allowed", a user cannot use the numeric keys to start a QUICK START workout. This configuration is designed to prevent users from inadvertently starting a QUICK START workout on treadmills that are integrated into a fitness networking system that requires the user to enter a USER ID and press ENTER before beginning a workout. A QUICK START workout can always be started by pressing the QUICK START key.

USING THE START MESSAGE SETUP

This configuration allows for a custom start-up message to be displayed before the default "Select Workout or Press Quick Start" message. The custom message can contain up to 52 characters.

CREATING/CHANGING A START MESSAGE

After entering the Manager's Configuration, scroll to the START MESSAGE SETUP option and press ENTER. Use the SPEED ARROW keys to select an available letter, number or special character. Use the INCLINE ARROW keys to move forward or backward throughout the message, or insert spaces, one character at a time. The current character will blink until the position is moved with the INCLINE ARROW keys.

SAVING A START MESSAGE

To save the START MESSAGE, press ENTER. "MESSAGE SAVED" will appear in the message center confirming the message has been saved. To exit the start message setup without saving, press the clear key twice. "MESSAGE NOT SAVED" will appear in the message center confirming the message has not been saved.

ERASING A START MESSAGE

After entering the Manager's Configuration, scroll to the START MESSAGE SETUP option and press ENTER. Press enter to enter the current START MESSAGE. Press the COOL DOWN key to erase the current START MESSAGE. "MESSAGE ERASED" will appear in the message center stating the message has been erased.

MARATHON MODE

Marathon Mode has no preset or settable goal. It allows the user to workout indefinitely. A workout in Marathon Mode ends only if the user chooses to end it or a stop system is activated.

To use the mode, enable Marathon Mode (see below).

While setting up a workout, enter a time value greater than the upper limit displayed on the console. Once the upper time limit is exceeded, the message center will display MARATHON MODE.

Within a workout, Marathon Mode can be immediately ended by pressing the Time Key. Pressing the Time Key makes it possible to set a time goal as long as it's not less than the time already spent in the workout.

To enable the Marathon Mode, enter the Manager's Configuration (see section 5.1). Using the TIME UP / DOWN arrow keys, scroll to MARATHON MODE. Once MARATHON MODE appears in the Message Center, press any of the INCLINE or SPEED UP/DOWN ARROW KEYS to toggle the mode from OFF to ON.

USER LANGUAGE SELECT

If enabled, this option allows users to select the language by which to interact with the unit during a workout.

To use the option, enable User Language Select (see below).

The console will display the message "SELECT LANGUAGE USING ARROW KEYS". The user can select from a list of available languages using any of the arrow keys. Press enter when the desired language appears to select that language. A workout can now be started using the selected language. Selecting a language is not necessary to begin a workout. Simply press the Quick Start key to start a workout or any of the program keys to begin workout programming using the default language.

The user may select from the following languages:

English, German, French, Italian, Dutch, Spanish, Portuguese, and Turkish. Japanese is available if the unit is equipped with a CCD console.

To enable the User Language Select option, enter the Manager's Configuration (see section 5.1). Using the TIME UP / DOWN arrow keys, scroll to LANGUAGE SEL. Once LANGUAGE SEL appears in the Message Center, press any of the INCLINE or SPEED UP/DOWN ARROW KEYS to toggle the mode from OFF to ON.

6 SERVICE AND TECHNICAL DATA

6.1 PREVENTIVE MAINTENANCE TIPS

The Life Fitness Treadmill is backed by the engineering excellence and reliability of Life Fitness and is one of the most rugged and trouble-free pieces of exercise equipment on the market today. Commercial Life Fitness Treadmills are among the most popular of aerobic trainers, regularly standing up to marathon use - 18 hours a day, seven days a week - in health clubs, colleges and military facilities the world over.

NOTE: *Safety of the equipment can be maintained only if the equipment is examined regularly for damage or wear. Keep the equipment out of use until defective parts are repaired or replaced. Pay special attention to parts that are subject to wear, as outlined below.*

REMARQUE : *pour conserver un matériel sûr, il convient de l'inspecter régulièrement afin de détecter tout signe d'usure ou d'endommagement. N'utilisez pas l'appareil tant que les pièces défectueuses n'ont pas été réparées ou remplacées. Portez une attention toute particulière aux pièces qui s'usent, comme indiqué ci-dessous..*

The following preventive maintenance tips will keep the Life Fitness Treadmill operating at peak performance:

- Clean the display console and all exterior surfaces regularly with mild soap and water or a mild household cleaner. Use only a soft cotton cloth. Apply cleaner to the cotton cloth before cleaning.
DO NOT use ammonia or acid based cleaners. DO NOT use abrasive cleaners. DO NOT use paper towels, DO NOT apply cleaners directly to equipment surfaces.*
- Check operation of the emergency stop system once a week.
- Check the operation of the stop button once a week.
- Inspect and vacuum the area directly surrounding and under the unit regularly.
- Vacuum around the striding belt regularly to keep debris from accumulating.
- Inspect exterior parts regularly for wear, particularly the striding belt, deck and line cord.
- Check to make sure the unit is properly leveled.
- Check the position (centering) of the striding belt.

The optimum operating position of the striding belt is from 1.5 inches (38 mm) to 2.0 inches (51 mm) from either side of the frame. If the striding belt travels beyond this position, see section 6.5, titled *How to Adjust and Tension the Striding Belt*, or contact Life Fitness Customer Support Services, for proper alignment instructions, 1-800-351-3737 (USA).

***NOTE:** *When cleaning the exterior of the unit, a non-abrasive cleaner and soft cotton cloth are strongly recommended. At no time should cleaner be applied directly to any part of the equipment; use non-abrasive cleaner on a soft cloth and then wipe the unit. Contact Life Fitness Customer Support Services for more details (refer to page one).*

6.2 PREVENTIVE MAINTENANCE SCHEDULE

ITEM	WEEKLY	MONTHLY	QUARTERLY	BI-ANNUAL	ANNUAL
DISPLAY CONSOLE ASSEMBLY					
Hardware			Inspect		
Console Overlay	Clean			Inspect	
Accessory Cups	Clean				Inspect
Stop Switch	Clean/Inspect				
Emergency Switch/Magnet	Clean/Inspect				
HANDLEBAR ASSEMBLY					
Hardware				Inspect	
Ergo™ Front Handlebar	Clean			Inspect	
Side Hand Rails	Clean			Inspect	
Lifepulse Sensors	Clean/Inspect				
FRAME ASSEMBLY					
Hardware				Inspect	
Motor Cover	Clean				
Motor Electronic Compartment		Vacuum Clean		Inspect	
Drive Belt				Inspect	
Drive Belt Anti-Static Bracket		Inspect			
Anti-Static Cords		Inspect			
Leg Levelers		Inspect/Adjust			
Front Roller				Inspect	
Rear Roller				Inspect	
Side Step Area	Clean		Inspect		
GENERAL					
Machine Level	*Inspect				
Striding Belt Centered	Inspect				
Frame, Toe Guards, Endcaps	Visual Inspect				
Tinsel	Visually Inspect if Treadmill has been Moved Replace Tinsel if Changing Belt and Deck				
*Use bubble level to inspect					

6.3 TROUBLESHOOTING THE TREADMILL

Malfunction	Probable Cause	Corrective Action
No Power	On/Off switch.	Turn the switch to the ON position.
	Insufficient power source.	<p>Plug treadmill into a dedicated 20 amp circuit. Refer to the Operations Manual.</p> <p>Using a voltmeter, verify power at outlet. If no power exists, reset circuit breaker at panel.</p>
	Damaged line cord.	Replace line cord. Contact Life Fitness Customer Support Services*.
	Line cord improperly seated in socket.	Inspect power connection at wall outlet and at machine for proper contact.
	Tripped circuit breaker.	<p>Verify that circuit breaker is not open. If open, reset circuit breaker.</p> <p>The location of the circuit breaker is on the outside of the treadmill, next to the ON/OFF switch. The breaker is a circular disk with a white button. The white button will have popped out. Press the white button at it's center to reset the circuit breaker.</p>

* See page one for contact information.

TROUBLESHOOTING THE TREADMILL (CONTINUED)

Malfunction	Probable Cause	Corrective Action
Striding Belt slips off-center	Uneven floor surface.	Check levelers and level treadmill. Check striding belt & re-tension as necessary. Refer to Section 6.5 "How to Adjust and Tension the Striding Belt."
Maximum speed is reduced	User is pushing striding belt. This occurs when the runner is running faster than the striding belt will travel, with the result of the striding belt being pushed with the runner's feet.	Instruct users not to push striding belt in either direction.
	User is stalling striding belt. This will occur with heavier users at lower striding belt speeds. The striding belt will "stall" if the user is traveling slower than the striding belt speed.	
	Striding belt/deck malfunction. The deck laminate worn through or the underside of striding belt glazed over (hard, glossy).	Replace belt and deck.
	Insufficient power source.	Plug treadmill into a dedicated 20 amp. circuit.
Rubbing sound from underneath machine	Foreign objects may be stuck underneath the machine.	Inspect underneath striding belt and machine. Remove any debris or objects that may cause interference with the treadmill.
	Tinsel is installed incorrectly.	Reposition tinsel on the outside of the striding belt.
Display does not illuminate when machine is powered on	Loose 10 pin connection at display console or DSP Motor control board.	Check all electrical connections for proper attachment. Contact Life Fitness Customer Support Services*.

* See page one for contact information.

TROUBLESHOOTING THE TREADMILL (CONTINUED)

Malfunction	Probable Cause	Corrective Action
Unit resets randomly or pauses	Insufficient power source.	Plug treadmill into a dedicated 20 amp circuit.
	Damaged ground prong on line cord.	Replace line cord.
	Line cord improperly seated in electrical outlet.	Inspect power connection at electrical outlet and at machine for proper contact.
	Emergency stop magnet not engaged.	Re-engage the emergency stop magnet.
	Towel or other item may be making contact with stop switch while user is running.	Move all possible obstructions off display console and handlebar.
	Stop switch is activated with very light pressure or returns slowly after being pressed.	Contact Life Fitness Customer Support Services*.
	Stop switch cable not making proper contact.	Contact Life Fitness Customer Support Services*.
	Pinched main wire harness.	Contact Life Fitness Customer Support Services*.
	Open ground path.	Contact Life Fitness Customer Support Services*.

* See page one for contact information.

6.4 TROUBLESHOOTING THE OPTIONAL HEART RATE CHEST STRAP

HEART RATE READING IS ERRATIC OR ABSENT ENTIRELY

Malfunction	Probable Cause	Corrective Action
Heart rate reading is erratic or absent entirely	Belt transmitter electrodes are not wet enough to pick up accurate heart rate readings.	Wet the belt transmitter electrodes (see section 3.2).
	Belt transmitter electrodes are not laying flat against the skin.	Ensure the belt transmitter electrodes are laying flat against the skin (see section 3.2).
	Belt transmitter needs cleaning.	Wash the belt transmitter with mild soap and water.
	Belt transmitter is not within 3.25 feet (one meter) of the heart rate receiver.	Make sure the chest strap transmitter is within three feet (one meter) of the heart rate receiver.
	Chest strap battery is depleted.	Contact Life Fitness Customer Support Services* for instructions on how to have the chest strap replaced.
Abnormally elevated heart rate readings	Electromagnetic interference from television sets and/or antennas.	Move the treadmill a few inches away from the probable cause, or move the probable cause a few inches away from the treadmill, until the heart rate readings are accurate.
	Electromagnetic interference from cell phones.	
	Electromagnetic interference from computers.	
	Electromagnetic interference from cars.	
	Electromagnetic interference from high voltage power lines.	
	Electromagnetic interference from motor driven exercise equipment.	
	Electromagnetic interference from another heart rate transmitter within three feet (one meter).	

* See page one for contact information.

6.5 HOW TO ADJUST AND TENSION THE STRIDING BELT

Do not move treadmill or place hands under treadmill while it is plugged into an electrical outlet!

THE BELT TENSIONING BOLTS

A 5/16-inch hex key wrench is required for this task. The Life Fitness Treadmill has access holes in the rear roller guards which allow access to the tensioning bolts. These tensioning bolts make it possible to adjust the tracking and centering of the striding belt (A) without removing the guards.

NOTE: It is extremely important that the treadmill be correctly leveled prior to any tracking adjustments. An unstable unit may cause striding belt misalignment. See the topic titled "How To Stabilize the Life Fitness Treadmill" in the Section 1.2, titled Set Up, prior to attempting any rear roller adjustments.

Before proceeding, it is helpful to visualize the REAR ROLLER (B) pivot point (C). Each adjustment made to one side of the ROLLER must be met with an equal and opposite adjustment (D) to the other side of the ROLLER to maintain an ideal belt tension at the pivot point.

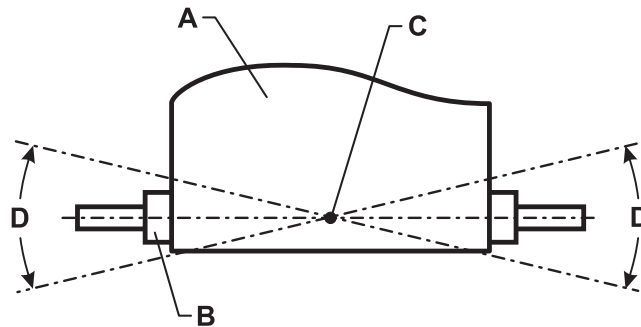

TRACKING (CENTERING) A STRIDING BELT

Two people are needed to perform this procedure.

- 1 Locate the two access holes to the belt tensioning bolts on each of the rear roller guards.
- 2 One person stands on the side rails of the treadmill and straddles the belt. This person presses the MANUAL work-out and sets the belt speed to 2.5 MPH (4.0 KPH).
- 3 If the striding belt has moved to the right, the second person turns the right tension bolt a quarter-turn clockwise and then turns the left tension bolt a quarter-turn counter-clockwise to make the striding belt track back to the center of the roller.

If the striding belt has moved to the left, turn the left tension bolt a quarter-turn clockwise and then turn the right tension bolt a quarter-turn counter-clockwise to make the striding belt track back to the center of the roller.

- 4 Repeat the adjustments until the striding belt appears centered. Allow the machine to continue running for several minutes at 4.0 MPH. (6.4 KPH) to observe if tracking remains stabilized.

NOTE: Do not exceed one full turn of the adjusting screws in either direction. If after one full turn the belt does not track properly, contact Customer Support Services. The phone numbers are listed on page one.

TENSIONING AN EXISTING STRIDING BELT

- 1 Enter the Manual workout and operate the treadmill for five minutes at 5.0 MPH (8.0 KPH).
NOTE: DO NOT RUN OR WALK ON BELT.
- 2 Reduce the speed to 2.0 MPH (3.2 KPH). Walk on the treadmill. Tightly grip the handrails and apply force with feet on the striding belt near the motor cover against the moving belt direction. If the belt slips, continue to Step 3. If it does not slip, the tension is correct.
- 3 Using the STOP key, stop the treadmill. Turn the belt tensioning bolts a quarter-turn clockwise for each side.
- 4 Repeat STEPS 2 and 3 until the belt no longer slips. Do not exceed one full turn (four quarter turns) per side when adjusting the belt tensioning bolts.
- 5 Enter the MANUAL workout and operate the treadmill at 2.0 MPH (3.2 KPH) check to insure proper tracking (See Section 6.5 "How to Adjust and Tension the Striding Belt"). If the striding belt drifts to the left or right see the topic titled *Tracking (Centering) an Existing or New Striding Belt* on the previous page.

Do not over-tighten the tensioning bolts while making belt adjustments. Over-tightening of bolts may over stretch and damage the striding belt or roller bearings. Do not exceed one full turn of either bolt in either direction.

6.6 PROACTIVE BELT WEAR NOTIFICATION

The treadmill proactively notifies the facility manager about belt wear through diagnostics. A single indicator is lit on the treadmill console (if manager-enabled) when a belt check is required. This indicator light is located in the upper left corner of the workout profile window.

- Automatic belt check reminder at 30,000 miles (48,000 km)
- Notification based on "Cannot Attain Target Speed" errors for specific user weights/speeds: (The actual error message is "UNABLE TO ATTAIN TARGET SPEED")

TO CHECK FOR NOTIFICATIONS:

To enter Belt/Deck Info, press and hold the PAUSE key and press the CLEAR key twice. Continue to hold down the PAUSE key until the MESSAGE CENTER displays the words "SERVICE MENU".

Then, release the PAUSE key, press the FAT_BURN key and then the ENTER_WEIGHT key. The MESSAGE CENTER displays "Belt/Deck Info" and then, if a notification has been triggered, displays a notification message "PLEASE CHECK BELT/DECK FOR SIGNS OF EXCESSIVE WEAR", . If no notifications exist, the Belt/Deck Info area will display belt/deck information.

NOTE: Notifications are automatically cleared once they have been displayed.

6.7 HOW TO OBTAIN PRODUCT SERVICE

1. Verify the symptom and review the operating instructions. The problem may be unfamiliarity with the product and its features and workouts.
2. Locate and write down the serial number of the unit, which is located on a plate near the power switch.
3. Contact the nearest Life Fitness Customer Support Services group (*refer to page one*).

7 SPECIFICATIONS

7.1 LIFE FITNESS CLASSIC SERIES TREADMILL SPECIFICATIONS

Designed use:	Heavy/Commercial
Maximum user weight:	400 pounds / 181 kilograms
Speed range:	0.5 - 14.0 MPH (0.8 - 23 KPH) in 0.1 increments
Elevation range:	0%-15% (in 0.1% increments)
Drive train:	AC motor with MagnaDrive™ motor controller
Motor type:	Variable Speed AC
Motor size:	4.0 HP continuous duty
Power requirements:	120 volt, 20 amp (U.S.). See Electrical Requirements for requirements outside the United States.
Rollers:	3.5 inch / 9 centimeter diameter, precision-crowned, front and back
Striding Belt:	60" Length x 20" Width (152 cm Length x 51 cm Width), multi-ply
Waxing system:	Lubricant-Infused Striding Belt
Deck type:	3/4" medium density reversible fiberboard
Shock Absorption System:	Patented FlexDeck® Shock Absorption System with Lifeprings™
Ergo™ Front Handrail:	Ergonomically shaped, overmolded elastomeric grips
Side handrails:	26" (66 cm) long, flared, cantilevered, overmolded elastomeric grips
Stop systems:	Red and Yellow magnetic lanyard emergency stop system and Session Stop Push Switch raised and prominently positioned
Workouts:	Fat Burn, Cardio, Hill, Random, Manual, Custom (6 customizable workouts), Life Fitness Fit Test, Army PFT, Navy PRT, Air Force PRT, Marines PFT, Gerkin, Physical Efficiency Battery (PEB), Speed Interval Training, Sport Training™ (5K and 10K), Calories Goal, Distance Goal, Time in Zone Goal, Heart Rate Hill™, Heart Rate Interval™, Extreme Heart Rate™
Levels:	20 (Hill, Random, 5K and 10K workouts)
Heart rate monitoring systems:	Patented Lifepulse™ digital contact heart rate and Polar® telemetry-compatible heart rate monitoring system
Console displays:	Elapsed time, total distance, total calories burned, Watts, METS, calories burned per hour, speed, incline, heart rate, distance climbed, time in zone, and Profile Window
Ports (2):	Type RJ45, interchangeable Network ready connection and Fitness Entertainment port (power compliant with Fitlinx CSAFESpecification dated August 4, 2004: 4.75VDC to 10VDC; maximum current of 85mA).

PHYSICAL DIMENSIONS:

Length:	83 inches / 211 centimeters
Width:	37 inches / 94 centimeters
Height:	63.5 inches / 161 centimeters
Weight:	425 pounds / 193 kilograms
Step-Up Height	11" / 28 centimeters

SHIPPING DIMENSIONS:

Length:	86.25 inches / 219 centimeters
Width:	42.5 inches / 108 centimeters
Height:	26.5 inches / 67 centimeters
Weight:	500 pounds / 227 kilograms

7.2 WARRANTY INFORMATION

WARRANTY COVERAGE: CLASSIC SERIES TREADMILL

WHAT IS COVERED:

This *Life Fitness* commercial exercise equipment ("Product") is warranted to be free of all defects in material and workmanship.

WHO IS COVERED:

The original purchaser or any person receiving the Product as a gift from the original purchaser.

HOW LONG IS IT COVERED:

All coverage is provided by specific Product according to the guidelines listed on the chart accompanying this warranty card.

WHO PAYS TRANSPORTATION & INSURANCE FOR SERVICE:

If the Product or any covered part must be returned to a service facility for repairs, **We, Life Fitness**, will pay all transportation and insurance charges for the first year. **You** are responsible for transportation and insurance charges during the second and third years (if applicable).

WHAT WE WILL DO TO CORRECT COVERED DEFECTS:

We will ship to you any new or rebuilt replacement part or component, or, at our option, replace the Product. Such replacement parts are warranted for the remaining portion of the original warranty period.

WHAT IS NOT COVERED:

Any failures or damage caused by unauthorized service, misuse, accident, negligence, improper assembly or installation, debris resulting from any construction activities in the Product's environment, rust or corrosion as a result of the Product's location, alterations or modifications without our written authorization or by failure on your part to use, operate and maintain the Product as set out in your Operation Manual ("*Manual*").

Two type RJ45 interchangeable Network ready and Fitness Entertainment ports are supplied with the Product. These ports comply with the Fitlinxx CSAFESpecification dated August 4, 2004 stating: 4.75VDC to 10VDC; maximum current of 85mA. Any Product damage caused by a load exceeding this FitlinXXSAFE specification is not covered by warranty.

All terms of this warranty are void if this product is moved beyond the continental borders of the United States of America (excluding Alaska, Hawaii and Canada) and are then subject to the terms provided by that country's local authorized Life Fitness representative.

WHAT YOU MUST DO:

Retain proof of purchase (*our receipt of the attached registration card assures registration of purchase information but is not required*); **use, operate and maintain** the Product as specified in the Manual; **notify** Customer Support Services of any defect within 10 days after discovery of the defect; if instructed, **return** any defective part for replacement or, if necessary, the entire Product for repair.

OPERATION MANUAL:

It is **VERY IMPORTANT THAT YOU READ THE MANUAL** before operating the Product. Remember to perform the periodic maintenance requirements specified in the Manual to assure proper operation and your continued satisfaction.

HOW TO GET REPLACEMENT PARTS & SERVICE:

Simply call Customer Support Services at (800) 351-3737 or (847) 451-0036, Monday through Friday from 8:00 a.m. to 6:00 p.m. Central Standard Time, and tell them your name, address and the serial number of your product (*refer to page 1 for Customer Services contact information*). They will tell you how to get a replacement part, or, if necessary, arrange for service where your product is located or advise you on how and where to ship the product for service.

Before shipping:

1. **obtain** a Return Authorization Number (**RA#**) from Customer Support Services
2. securely **pack** your console (*use the original shipping carton, if possible*)
3. **write** the **RA#** on the outside of the carton
4. **insure** the console, and
5. **include** a letter explaining the defect or problem and a copy of your proof of purchase if you believe the service is covered by warranty

EXCLUSIVE WARRANTY:

THIS LIMITED WARRANTY IS IN LIEU OF ALL OTHER WARRANTIES OF ANY KIND EITHER EXPRESSED OR IMPLIED, INCLUDING BUT NOT LIMITED TO THE IMPLIED WARRANTIES OF MERCHANTABILITY AND FITNESS FOR A PARTICULAR PURPOSE, AND ALL OTHER OBLIGATIONS OR LIABILITIES ON OUR PART. We neither assume nor authorize any person to assure for us any other obligation or liability concerning the sale of this Product. Under no circumstances shall we be liable under this warranty, or otherwise, of any damage to any person or property, including any lost profits or lost savings, for any special, indirect, secondary, incidental or consequential damages of any nature arising out of the use of or inability to use this Product. Some states do not allow the exclusion or limitation of implied warranties or of liability for incidental or consequential damages, so the above limitations or exclusions may not apply to you.

CHANGES IN WARRANTY NOT AUTHORIZED:

No one is authorized to change, modify or extend the terms of this limited warranty.

EFFECT OF STATE LAWS:

This warranty gives you specific legal rights and you may have other rights which vary from state to state.

OUR PLEDGE TO YOU:

Our Products are designed and manufactured to the highest standards.

We want you completely satisfied with our Products and will do everything possible under the terms of this warranty to keep you secure in knowing you have bought the best!

MODEL	7 Year	2 Years	1 Year	6 Months
Classic Series Treadmill	<ul style="list-style-type: none"> ✓ Lifespring™ Shock Absorbers ✓ Drive Motor ✓ Frame 	<ul style="list-style-type: none"> ✓ Electronics (i.e. PCBs such as motor controller and console board) 	<ul style="list-style-type: none"> ✓ Mechanical (i.e. belt and deck) ✓ Electro-Mechanical (i.e. switches, lift motor, electrodes) ✓ Labor 	<ul style="list-style-type: none"> ✓ Console Overlay ✓ Line Cord ✓ Plastic Parts

NOTE - Once any commercial product is placed in a private residence (home), it automatically becomes covered under that product category's consumer warranty. Warranty coverage begins at the original date of sale.



M051-00K58-C362

Life Fitness World Headquarters
5100 North River Road
Schiller Park, IL 60176 USA

Free Manuals Download Website

<http://myh66.com>

<http://usermanuals.us>

<http://www.somanuals.com>

<http://www.4manuals.cc>

<http://www.manual-lib.com>

<http://www.404manual.com>

<http://www.luxmanual.com>

<http://aubethermostatmanual.com>

Golf course search by state

<http://golfingnear.com>

Email search by domain

<http://emailbydomain.com>

Auto manuals search

<http://auto.somanuals.com>

TV manuals search

<http://tv.somanuals.com>