

Life Fitness Service Kit Instruction (GK61-00002-0008)

HOW TO... REPLACE ROCKER ARMS

Tools required: Snap ring pliers, 3/8 Socket set, and Standard wrench set

Step 1

Unplug the unit at the electrical outlet.

Step 2

Raise the boot covers on the upper arms then remove three mounting bolts from each upper arm.

Step 3

If equipped, remove the clevis covers.

Step 4

Remove the nut and bolt securing the PEDAL LEVER to the ROCKER ARM, and lower the pedal lever.

Step 5

Remove the END CAP and internal snap from the rocker arm.

Step 6

Remove the rocker arm.

Step 7

Install the new rocker arm in reverse order.

NOTE: For units without clevis covers, plug the square holes in the bottom of the rocker arms with the supplied plugs.

NOTE: For units with clevis covers, insert the nylon grommets (nuts) as supplied, then install clevis covers.

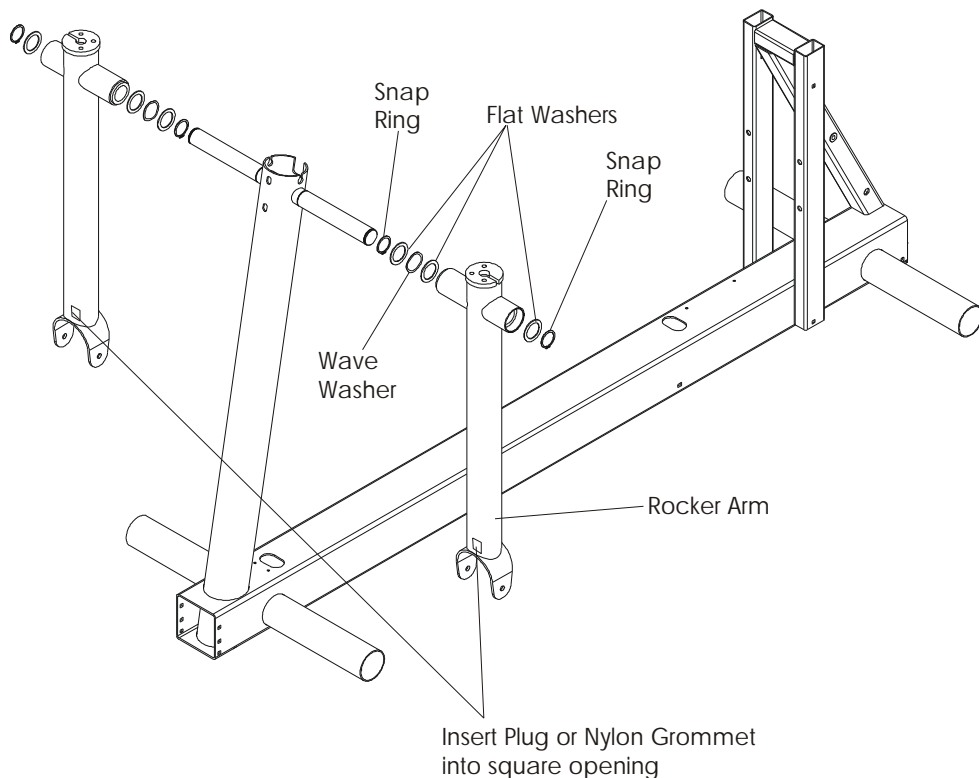
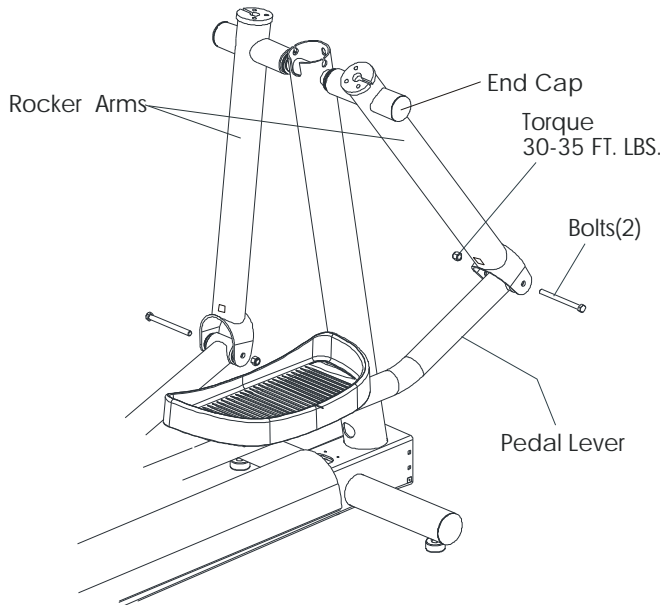

Free Manuals Download Website

<http://myh66.com>

<http://usermanuals.us>

<http://www.somanuals.com>

<http://www.4manuals.cc>

<http://www.manual-lib.com>

<http://www.404manual.com>

<http://www.luxmanual.com>

<http://aubethermostatmanual.com>

Golf course search by state

<http://golfingnear.com>

Email search by domain

<http://emailbydomain.com>

Auto manuals search

<http://auto.somanuals.com>

TV manuals search

<http://tv.somanuals.com>