

**Start your system installation with the
“System Installation” section of the User Manual**

**All LightSPEED speakers should be in
accordance with Uniform Building Code, state
and local building department requirements**

**Step 1: Selecting Speaker
Mounting Locations**

Four WMQ™ Wall Speakers are ideal in rooms up to 1600 square feet with a ceiling height of 8–12 feet.

Before starting the system installation, speaker placement needs to be decided. Optimum sound pattern is achieved when the speakers are staggered on the four walls as shown in figure 1. Speakers should NOT be placed directly opposite of each other.

Ceiling height determines how high the speaker is set on the wall. Increased ceiling height allows the speakers to cover a larger area.

If the classroom is not rectangular, does not have suspended ceilings, or has a ceiling that is not horizontal (flat), call LightSPEED Technical Support (800.732.8999) to determine optimum speaker placement.

Step 2: Mounting the Speakers

- A. Identify a suitable location for the receiver/amplifier where it is easily accessible, close to a power outlet, and at least 6 feet away from any computers.
- B. Remove the mounting bracket from the WMQ speaker by unscrewing the knobs on the side of the speaker.
- C. Use the bracket as a template to mark the position for the two screws where the bracket will be fastened (see figure 2). Keeping the bracket as horizontal as possible, push a sharp object through the template into the wall. These mark where the wall mounting screws will be placed.
- D. Each speaker bracket comes with two mounting screws, two washers and two sheet rock mollies.
 - i. If the walls are wood, screw the mounting bracket to the wall with two mounting screws and washers at the marked spacing. Then screws should be inserted into the wood so that the bracket is held snugly to the wall.
 - ii. If the walls are sheet rock, drill pilot holes (3/16” to 1/4” diameter) in the sheet rock at the marked spacing. Screw the two sheet rock mollies into the pilot holes until they are flush with the surface. The screws and washers should be inserted into the mollies so that the bracket is held snugly to the wall.
- E. Repeat step B for all speaker locations. Do not attach the speakers to the brackets yet.

Speaker Placement

Figure 1:

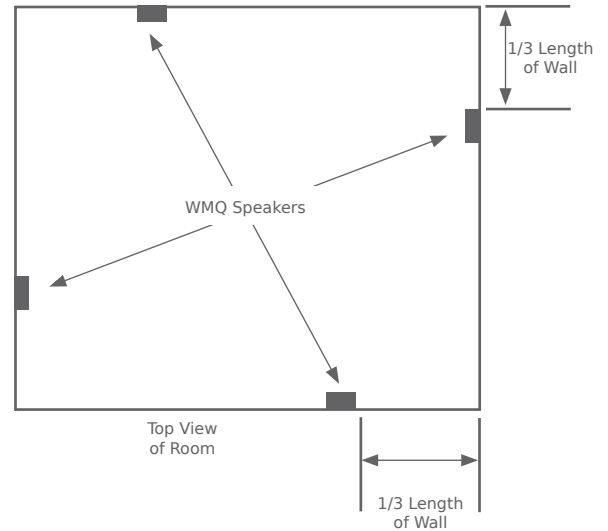

Installing the Speaker

Figure 2:

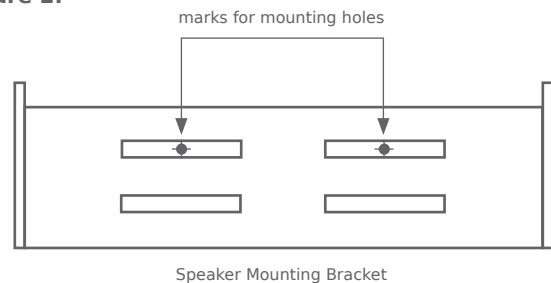

Wiring Diagram

Figure 3:

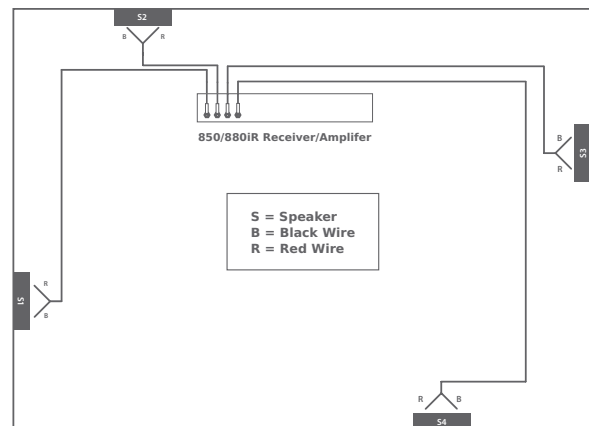

Start your system installation with the
“System Installation” section of the User Manual

All LightSPEED speakers should be in
accordance with Uniform Building Code, state
and local building department requirements

Step 3: Connecting and Routing Speaker Wire

- A. Locate the four coils of wire (two 50 feet, two 75 feet) and place them next to the speakers. Each speaker requires one length of wire.
- B. At the first speaker, connect one end of the wire to the terminals on the back of the speaker. Connect the red wire to the red terminal by depressing the tab and inserting the wire into the connector hole. Then connect the black wire to the black terminal in the same manner.
- C. Attach the speaker to the mounting bracket. Place the speaker between the mounting bracket arms and secure on each side with the plastic angle adjustment knobs. Angle the speakers down to “aim” the sound halfway across the room. Tighten knobs snugly, but do not over tighten and strip the screw threads.
- D. Run wire by best route back to the receiver/amplifier. For permanent installations, it is usually best to route wire overhead when possible using wire raceway to conceal. Running speaker wire above suspended ceiling tiles is common practice, but must be done in accordance with building and electrical codes. If the room has high ceilings it might be best to route the wire around the room floor staying close to the walls. Do not connect the wires to the receiver/amplifier yet.

Step 4: Connecting Speaker Wire to Receiver/Amplifier 850iR (see figure 4)

- A. Connect the wire coming from each speaker into the SPEAKER OUTPUT binding post connectors.
 - i. Unscrew the red and black caps on the binding post connectors for all four speakers.
 - ii. Insert the bare red wire into the hole that was revealed by unscrewing the red cap. Insert the bare black wire into the hole on the black binding post. Repeat with all four speaker wires.
 - iii. Screw the caps back down onto the wire until they are secure.
 - iv. Make sure the speaker on/off switch next to the jack is switched to the “ON” position.

880iR (see figure 5)

- i. Unplug the euro-block style connector from the SPEAKER 1 jack.
- ii. Insert the black wire (-) into the left side of the connector and lock it down by tightening the screw on top of the connector.
- iii. Insert the red wire (+) into the right side of the connector and lock it down in the same manner.
- iv. Plug the connector back into the SPEAKER 1 jack and lock it into the amplifier by tightening the two side screws.
- v. The corresponding speaker volume knob should be left in the 12:00 position.

Step 5: Equalization

- A. Each receiver/amplifier includes an 8-band equalizer that allows users to fine-tune their classroom based on different room characteristics. Figure 6 shows the factory recommended settings for the WMQ speaker. Since all rooms are different, this is only meant as a starting point and may require some adjustment.
- B. The ideal sound is a crisp, clear sound with no feedback. Volume levels should be set to a point you can barely hear your own voice. The goal is to try to replicate the sound of your voice as if the child is sitting directly in front of you, not to amplify your voice at high volumes. Because of the classroom size and constant proximity to the speaker, the system can product feedback (squealing) if the volume level is set too high.
- C. Return to the “Initial Set-up” section of the user manual to complete the remaining steps of the system installation.

Connecting Speaker Wire to Back of Receiver/Amplifier

Figure 4:

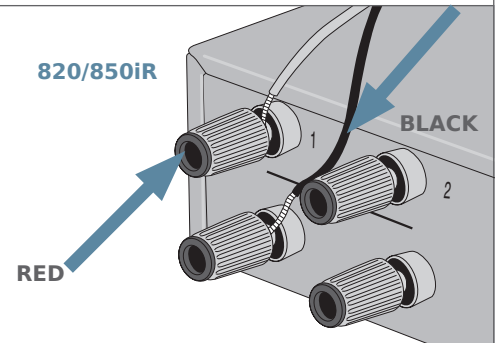
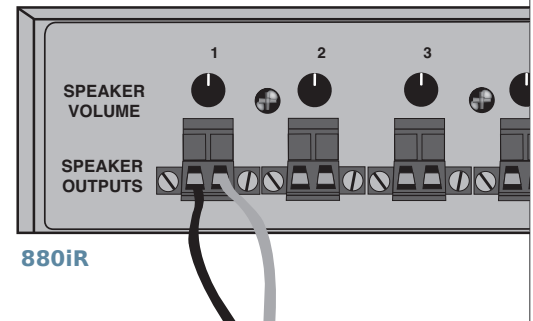
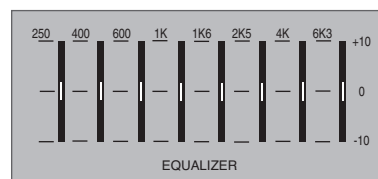

Figure 5:



EQ Setting

Figure 6:



Free Manuals Download Website

<http://myh66.com>

<http://usermanuals.us>

<http://www.somanuals.com>

<http://www.4manuals.cc>

<http://www.manual-lib.com>

<http://www.404manual.com>

<http://www.luxmanual.com>

<http://aubethermostatmanual.com>

Golf course search by state

<http://golfingnear.com>

Email search by domain

<http://emailbydomain.com>

Auto manuals search

<http://auto.somanuals.com>

TV manuals search

<http://tv.somanuals.com>