

705iR PORTABLE INFRARED WIRELESS  
AMPLIFICATION SYSTEM

# 705iR

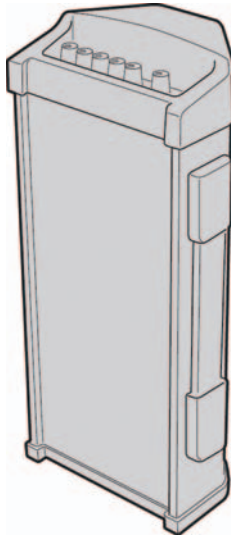

USER'S MANUAL



---

## Table of Contents

---

Quick-start Guide .....	1
705iR Components .....	2
Overview/Top Panel Controls .....	3
Power & Signal Indicators/Rear Panel Controls .....	4
LT-70 LightMic™ Transmitter Controls and Connections .....	5
705iR Receiver/Amplifier Positioning/Power Options/Charging .....	6
LT-70 LightMic™ Transmitter Charging Instructions .....	7
LT-70 LightMic™ Transmitter Operating Instructions .....	8
HM-70 Handheld Microphone Overview and Controls .....	9
HM-70 Handheld Microphone Operating Instructions .....	10
Input from External Audio Equipment/Output to Personal FM Transmitter .....	10
Tips on Using Classroom Amplification .....	11
Overall System Specifications .....	12
Components and Accessories .....	13
Warranty Information .....	14
User Notes .....	15

---

---

## *Quick-start Guide:*

Simply follow the six steps on this page to get your 705iR up and running in a matter of minutes!

To take full advantage of the features the 705iR has to offer, as well as its applications, please take time to read through the entire manual.



- 
- 1** *Plug battery charger/power supply into 705iR.*
  - 2** *Plug one end of power cable into battery charger/power supply and the other end into AC outlet.*
  - 3** *To turn 705iR on, rotate CH A POWER knob clockwise.*
  - 4** *Switch LT-70 LightMic™ Transmitter to the ON position (confirm LT-70 is set to CH A.)*
  - 5** *Clip LT-70 to black lavalier cord. Loop cord around neck. Adjust cord length until the top of the LT-70 rests on the collarbone.*
  - 6** *Turn CH A POWER knob to adjust volume to desired level.*

## Greetings!

Congratulations on your purchase of the 705iR Portable Infrared Wireless Amplification System! Please take a moment to review this manual, as it will help you operate this easy-to-use system, and maximize your investment by caring for and maintaining each component.

Pay careful attention to the instructions on batteries and battery charging to extend the operational life of the batteries.

## 705iR Components

Listed on this page are the standard components that are included in the 705iR Portable Infrared Wireless Amplification System:

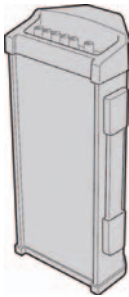

705iR Receiver/Amplifier

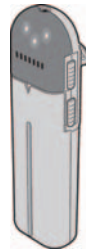

LT-70 LightMic™ Transmitter

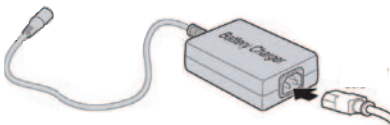

Battery Charger/Power Supply

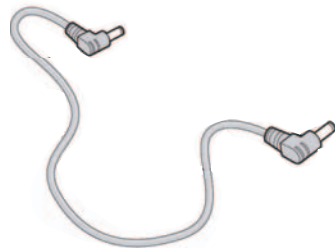

Microphone Charging Cable

## Overview

The 705iR is a lightweight, multipurpose, portable amplification system powered by rechargeable batteries or AC power. It is designed to allow teachers to speak in normal conversational tones and yet be heard clearly by every student in the classroom.

The 705iR comes standard with the LT-70 LightMic™ pendant-style transmitter/microphone. The system may be used with two microphones accommodating team teaching or student interaction. The second microphone can be an additional LightMic or the HM-70 handheld microphone. Other optional microphones can also be plugged into the LightMic. Contact LightSPEED for assistance in selecting optional microphones.

## Top Panel Controls

1. **CH A POWER:** This knob turns on the power for the 705iR and controls the Channel A volume. We recommend using Channel A if you are using a single microphone for your system. Turn the knob clockwise to increase volume.
2. **CH B VOLUME:** This knob controls the volume for Channel B. You must first turn the 705iR ON with the CH A POWER knob, then turn the CH B VOLUME knob clockwise to increase volume. Use Channel B when using a second microphone.
3. **TREBLE:** This knob controls the high-frequency sound of the 705iR.

*Ch. A and Ch. B LEDs are hidden by their corresponding volume knobs in this diagram.*

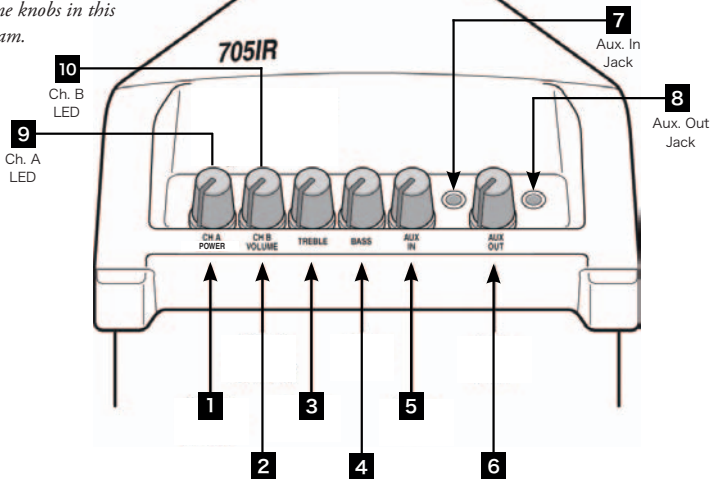

## Top Panel Controls (cont.)

4. **BASS:** This knob controls the low-frequency sound of the 705iR.
5. **AUX IN VOLUME:** This knob controls the volume level of an external audio source that is plugged into the AUX IN jack. An example would be a computer, TV, VCR, CD or cassette player.
6. **AUX OUT VOLUME:** This knob controls the audio level going to external equipment when plugged into the AUX OUT jack. For example, a personal FM transmitter or tape recorder.
7. **AUX INPUT JACK:** This 3.5 mm jack is used to connect to an external audio source.
8. **AUX OUTPUT JACK:** This 3.5 mm jack provides a line-level audio output that can be connected to a personal FM system or tape recorder.

## Power and Signal Indicators

9. The LED light located above the CH A POWER knob turns red momentarily when the system power is turned ON.

When a transmitter/microphone set to Channel A is turned on, the Channel A LED glows green to indicate your transmitter's signal is being received by the amplifier.

10. The LED above CH B VOLUME turns green to indicate a signal is being received from a transmitter set to Channel B.

## Rear Panel Connections

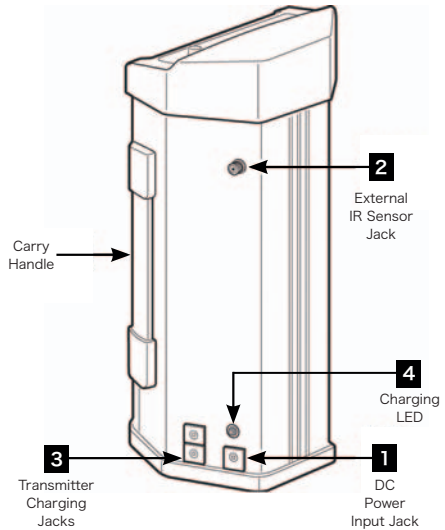

1. **DC POWER INPUT JACK:**  
This input connects to the 16 V AC/DC adaptor that comes with the 705iR. The adaptor is used to either charge the internal battery pack or power the 705iR with AC power.
2. **EXTERNAL IR SENSOR JACK:**  
This jack is provided for connection of an additional sensor (for larger or odd-shaped rooms).
3. **TRANSMITTER CHARGING JACKS:** This connector is used to connect the charging cable to the LightMic transmitter or the optional HM-70 handheld microphone for daily battery recharging.
4. **CHARGING LED:** This LED glows red when the 705iR battery is charging and glows green when fully charged.

## LT-70 LightMic™ Transmitter Controls and Connections

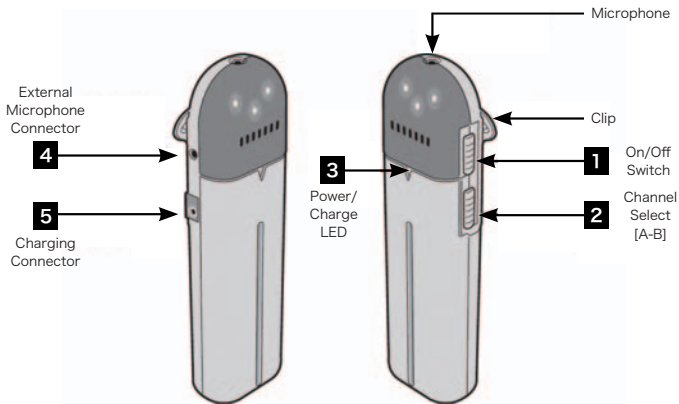

- 1. ON/OFF SWITCH:** This switch, located on the side of the LightMic, turns the unit on or off. The red triangle-shaped LED on the front of the LightMic will light when power is on.
- 2. CHANNEL SELECT SWITCH:** This switch allows for selection between Channel A or B. If you are using a single microphone/transmitter for your system, we recommend using Channel A.
- 3. POWER/CHARGE LED INDICATOR:** This triangle-shaped LED is two-color. It glows red when the LightMic is powered on, green when charging and goes out when fully charged.
- 4. EXTERNAL MICROPHONE CONNECTOR:** Use the 3.5 mm MIC jack for the optional TK-250 headset microphone.
- 5. CHARGER CONNECTOR:** Use the jack labeled CHARGER to connect the charging cable from the 705iR to the LightMic for daily battery recharging.

## 705iR Receiver/Amplifier

### [ Positioning ]

The 705iR has a built-in speaker, which should be directed toward the area of the classroom where the students are sitting. The unit can be placed on a table top or bookshelf at a height of 36 to 60 inches.

The ideal position in the classroom is centered along the longest wall. However, due to different classroom setups, this is not always possible. Here is a quick guide to choosing a location:

**Best:** Centered on the longest wall

**Good:** Centered on the short wall

**Okay:** In a corner

**Avoid:** Placing the unit directly in front of a window.

### [ Two Power Options: AC or Battery ]

The 705iR operates with battery power in a portable application, or you can leave the system connected to AC power for a more permanent application.

#### *When using AC power:*

**If the 705iR will primarily be used in a fixed location within the classroom, LightSPEED recommends using AC power.**

- a. Plug the power supply into a standard AC outlet.
- b. Plug the other end of the power supply/charger into the DC power jack.
- c. Turn the CH A POWER on and set an appropriate volume level. The 705iR may be left on at all times when using AC power.

#### *When Using Battery Power:*

**If the 705iR will be moved within a classroom or to different classrooms, battery-powered will provide the most flexibility.**

## Charging the 705iR

- a. Ensure the power switch (CH A POWER) on top of the 705iR is turned off.
- b. Plug the power supply/charger cable into a standard AC outlet.
- c. Plug the other end of the power supply/charger into the DC power jack on the back of 705iR. The LED above the DC will glow red. A solid green LED indicates the 705iR is fully charged.
- d. Charge the batteries completely prior to first use. Charging time can take as long as 10 to 14 hours. When fully charged, the circuit switches to a trickle charge, which will not overcharge or damage the batteries.

### [ battery charger and AC connection ]

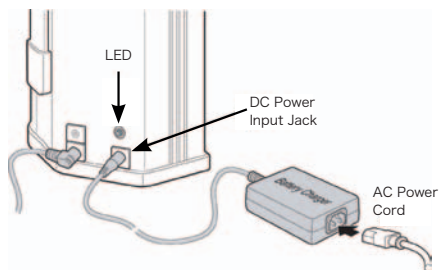



## LT-70 LightMic™ Transmitter/Microphone

*The rechargeable NiMH batteries must be fully charged before regular classroom operations.*

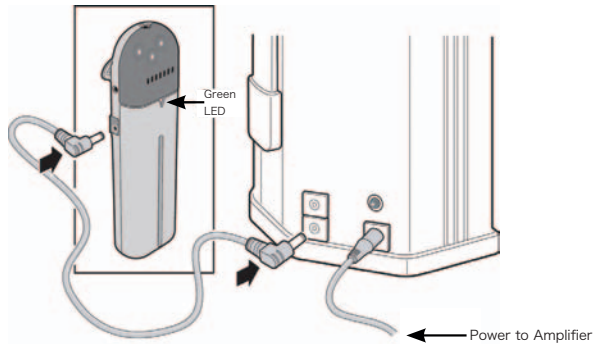

### Charging the LightMic

- a. Ensure the LightMic and the 705iR are turned OFF. The 705iR must be connected to AC power in order to charge the LightMic.
- b. The LightMic's rechargeable batteries are factory installed. Plug one end of the charging cable firmly into the jack labeled CHARGER on the side of the LightMic. Connect the other end of the charging cable to the charging jack on the back of the 705iR.
- c. The triangle-shaped light on the front of the LightMic transmitter glows green when the cable is connected and charging correctly. The light goes out when fully charged.
- d. The batteries will fully charge in about 8 to 12 hours.
- e. It is best to leave the LightMic charging until used, since the batteries slowly lose their charge when not in use.
- f. Once the batteries are charged, remove the charging cable from the LightMic.
- g. NiMH batteries will maintain their charge for a full day of normal classroom use.
- h. With proper care, NiMH batteries will provide service for at least one year. If battery or charging problems occur, contact LightSPEED Service at 800.732.8999.

*However, do not leave the LightMic plugged into the charger for more than 10 days, as it will significantly shorten battery life.*

#### [ caution! ]

**Do not attempt to charge alkaline batteries—they can overheat and expand, creating a significant hazard and damaging the LightMic.**  
*(This is not covered by the warranty.)*

## Operating the LightMic

- a. The LightMic has a built-in microphone. Once the transmitter is switched on, the microphone is activated.
- b. The LightMic may be used as a hand-held mic or a hands-free pendent style microphone by clipping the LightMic on the supplied lavalier cord.

*Place the lavalier cord around your neck, and adjust the length so the top of the LightMic rests on the collar bone.*

- c. On the side of the LightMic is the Channel A/B slide switch. Slide the switch to the “A” position. (If a second LightMic is used for simultaneous operation, set one LightMic to Channel A and the second LightMic to Channel B.)
- d. Slide the ON/OFF switch on the side of the LightMic to ON. The triangle-shaped light on the front glows red, indicating the microphone is charged and ready for use.
- e. When the LightMic transmitter power switch is slid to OFF, the microphone power is turned off.

## Adjusting Volume

*Volume is set by adjusting the volume control on the 705iR.*

- a. Make sure the 705iR is switched ON.
- b. Ensure the LightMic is switched ON and the triangle-shaped LED on the front of the LightMic is glowing red. The LED next to the CH A knob on the 705iR will also glow, indicating that the 705iR is receiving the LightMic signal and is ready for use.
- c. Adjust the volume of the receiver by turning CH A POWER clockwise. Be careful not to stand directly in front of the speaker as feedback may occur.
- d. Speak at a normal level and slowly turn the volume knob clockwise to increase the loudness of the speaker until the sound level is adequate for the room.

### [note:]

*Feedback or “squealing” may occur if the volume is set too high. Reducing the loudness of the speakers with the volume control usually eliminates feedback.*

## Operating two transmitter/ microphones simultaneously

The 705iR system has two independent receivers—Channel A and B. This makes it possible to operate two transmitter/microphones simultaneously. Follow the instructions below when using a second transmitter/microphone:

- a. Set each transmitter/microphone to separate channels. For example if you are using two LightMics, set one to Channel A and the other to Channel B. If you are using one LightMic and one HM-70 handheld microphone, set the LightMic to Channel A and the HM-70 to Channel B.

*When the 705iR is receiving a signal from the transmitter microphone(s):*

- CH A POWER indicator will glow green on the 705iR if you select Channel “A” on the LightMic transmitter.
- CH B VOLUME indicator light will glow green if Channel “B” is selected.
- When simultaneously operating two transmitters/microphones, both indicator lights will glow.

## Optional HM-70 Handheld Microphone

The HM-70 handheld microphone is an optional microphone that can be ordered from LightSPEED. It can be used alone or in tandem with the LT-70 LightMic.

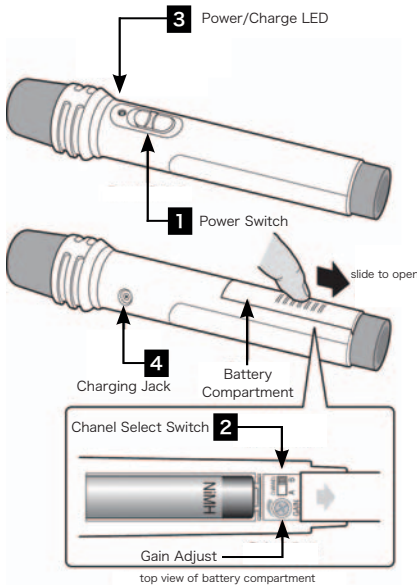

## Optional HM-70 Handheld Microphone Controls

1. **POWER SWITCH:** This 3-position switch allows you to turn the microphone on (up position), mute the microphone (middle position), and turn off the microphone (down position). The red LED above the switch lights when the switch is in the “MUTE” or power “ON” positions.
2. **CHANNEL SELECT SWITCH:** This switch allows you to choose between Channel A or Channel B. This switch is set to Channel B at the factory.
3. **POWER/CHARGE LED INDICATOR:** This two-color LED indicator is located directly above the power switch. It glows red when the HM-70 is powered on and glows green when charging.
4. **CHARGING JACK:** Use the jack labeled CHARGER to connect the charging cable from the 705iR to the HM-70 for daily battery recharging.

### [ caution! ]

**Do not attempt to charge alkaline batteries—they can overheat and expand, creating a significant hazard and damaging the LightMic.**

*(This is not covered by the warranty.)*

## Optional HM-70 Handheld Microphone Operating Instructions

### Charging

*Rechargeable batteries are pre-installed.*

- a. Turn off the HM-70 by sliding the ON/OFF switch all the way down and turn off the 705iR.
- b. Connect one end of the charging cable to one of the CHARGE jacks on the back panel of the 705iR. Connect the other end of the charging cable to the charging jack on the side of the HM-70. The power indicator LED will glow green when the charging cable is connected and charging correctly.
- c. The batteries fully charge in 8 to 12 hours. Once the batteries are charged, remove the charger cable from the HM-70.

*NiMH batteries maintain their charge for a full day of normal classroom use. Always turn the HM-70 off when not in use.*

### Operation

*The Channel A/B switch is located inside the battery compartment. The switch is set to Channel B at the factory.*

- a. Slide the ON/OFF switch on the side of the HM-70 all the way up. The power indicator LED will glow red and stay on. (There is a center MUTE position if you wish to leave power on but temporarily cease transmission of your voice.)
- b. Do not adjust the audio gain adjuster that is located in the battery compartment. It has been preset by factory technicians and is not intended as a volume control.

### Holding and Positioning

- a. When holding the HM-70, grip the barrel in the center, silver section below the ON/OFF switch. Do NOT grip the HM-70 around the bottom, covering the black infrared sensors encircling the base. This interrupts signal transmission from the microphone to the receiver. Speak directly into the top of the microphone at a normal level, holding the head about 2 inches from your mouth, no lower than chin height.

### Input From External Audio Equipment

Below are instructions on how to connect an external audio device like a computer, CD player, cassette player, VCR and TV to the 705iR.

1. Connect a cable from an audio source to the 3.5 mm AUX IN jack next to the AUX IN volume knob on the top of the 705iR.
2. With the 705iR turned on, adjust the AUX IN volume to a desired level.

### Output to Personal FM Transmitter

1. Using a cable with a 3.5 mm connector at one end, connect the AUX OUT of the 705iR to the input jack of the FM transmitter. Different manufacturers use different size audio input jacks on the transmitter. The LightSPEED LES-370 requires a the CA-MMC 3535 cable.
2. With the 705iR turned on, adjust the AUX OUT volume to a desired level.

## Tips on Using Classroom Amplification

*These helpful suggestions are provided to maximize the successful use of your new 705iR Portable Infrared Wireless Amplification System.*

- Speak in a natural voice. A normal conversational speech level will provide an adequate signal. It is not necessary to increase the intensity of your voice—the amplification system provides adequate amplification (approximately 5 - 10 dB) above ambient room noises.
- Avoid wearing jewelry that may rub or bump against the microphone.
- Turn the LightMic OFF during private conversations with a student, parent, or other classroom visitor. You can also cover the LED lens on top of the LightMic to block the signal.
- Recharge batteries each night. When recharged nightly, operating time (actual usage) for the transmitters will last through a typical school day. Your rechargeable batteries will last for a normal school year when cared for properly.
- Do not use or attempt to recharge disposable alkaline batteries—they will overheat and expand, creating a significant hazard and damaging the transmitter. (This type of damage is not covered under warranty.)
- Connecting the 705iR into a standard electrical socket using the supplied 16 V DC power supply/charger charges the batteries. It can also be used as a direct power source for the amplifier.

If you review these instructions and still have questions, write down the serial number and model number of your system and call LightSPEED Technical Services at 800.732.8999, 7 a.m. - 5 p.m. PST.

---

## Overall System Specifications:

---

Carrier Frequencies (IR).....	2.06/2.54 MHz
Maximum Deviation.....	+/- 50 kHz
Dynamic Range.....	> 70 dB
Signal-to-Noise Ratio.....	> 70 dB
Total Harmonic Distortion.....	< 4 %
Frequency Response.....	100 Hz - 10 kHz

## Receiver/Amplifier Specifications:

Receiver Type.....	Superheterodyne
Receiver Sensitivity.....	6 $\mu$ V for 60 dB S/N
Image and Spurious Rejection.....	> 70 dB

## Amplifier Specifications:

Total Harmonic Distortion.....	< 1 % (Output = 1 W)
Power Output.....	12 W RMS
Speaker Type.....	Standard Cone (4 inches)
Speaker Load Impedance.....	4 Ohms
Adjustable Tone Controls.....	+/- 8 dB (100 Hz - 10 kHz)
Power Supply (UL Listed).....	16 V/2.0 A
Battery Power (1-year warranty).....	12 V NiMH Battery Pack
Dimensions.....	13.25 x 5.75 x 4 (H x W x D inches)
Weight.....	5 lbs. w/battery pack

## Transmitter Specifications:

Audio Distortion.....	< 1%
Spurious Emissions.....	< 30 dB
Built-in Microphone.....	Uni-directional Electret
Battery Power (1-year warranty).....	2 AA NiMH Rechargeable
Dimensions.....	1.4 x 1 x 4.6 (W x D x H inches)
Weight.....	3.04 oz. (w/batteries)

---

---

## Individual Components and Optional Accessories

---

<b>LES-LT70:</b>	“LightMic” Rechargeable Microphone/Transmitter with lavalier cord, batteries and charging cable
<b>LES-HM70:</b>	Handheld Microphone/Transmitter with batteries and charging cable
<b>BA-NH1:</b>	Rechargeable AA Battery (Nickel Metal Hydride)
<b>AC-TCC7:</b>	Charging Cable for LT-70 and HM-70 to be used with 705iR
<b>AC-LTCB:</b>	Lavalier cord for LT-70
<b>PS-16V-2.0:</b>	Power Supply/Battery Charger for 705iR
<b>AC-SP705:</b>	Carrying Case for 705iR
<b>MC-TK250LTM:</b>	Optional Noise-canceling Headset Microphone to be used with LT-70
<b>IR-SR70:</b>	Optional External Infrared Sensor to expand the range for large or odd-shaped rooms.
<b>CA-MMC35:</b>	Audio Input Cable (RCA connector to 3.5 mm mono)
<b>CA-MMC3535:</b>	Audio Patch Cable (3.5 mm mono to 3.5 mm mono)
<b>CA-MMC2535:</b>	Audio Patch Cable (2.5 mm mono to 3.5 mm mono)

---

---

## Five-Year Limited Warranty to Original Purchaser

---

*The LightSPEED 705iR Portable Infrared Wireless Amplification System is warranted against malfunction due to defects in materials and workmanship for a period of five years beginning at the date of the purchase. Batteries and the optional TK-250 Headset Microphone are guaranteed for one year. Products will be repaired or replaced at LightSPEED's option during the warranty period.*

*Warranty does not extend to finish, appearance, or malfunctions due to abuse or misuse. Repairs performed by any other than LightSPEED will void this warranty. Our Service Department (800.732.8999, 7 a.m. – 5 p.m., PST) will handle all your repair/replacement needs.*

---



---

## User Notes

---

Record your system serial numbers and purchase information. This is helpful when ordering additional components, accessories, and/or warranty service.

<b>standard components</b>	<b>serial number</b>
705iR	
LT-70 LightMic	
Power Supply	
<b>optional components</b>	<b>serial number</b>
HM-70 Handheld Microphone	
TK-250 Headset Microphone	
SR-70 IR Sensor	

---

---

---

---

---

---

---

---

---

---

---

LIGHTSPEED TECHNOLOGIES, INC.

11509 SW HERMAN RD

TUALATIN, OR 97062

800.732.8999

WWW.LIGHTSPEED-TEK.COM



## Free Manuals Download Website

<http://myh66.com>

<http://usermanuals.us>

<http://www.somanuals.com>

<http://www.4manuals.cc>

<http://www.manual-lib.com>

<http://www.404manual.com>

<http://www.luxmanual.com>

<http://aubethermostatmanual.com>

Golf course search by state

<http://golfingnear.com>

Email search by domain

<http://emailbydomain.com>

Auto manuals search

<http://auto.somanuals.com>

TV manuals search

<http://tv.somanuals.com>