

LIGHTNING AUDIO®

DIGITAL

Mono

Amplifiers

\$1.6000
\$1.10000

STORM



INTRODUCTION

INNOVATE OR DISINTEGRATE!

Thank you for purchasing the Lightning Audio Storm Amplifier.

Our customers have come to expect that Lightning Audio pushes the edge in audio. Now we will push the edge in the amplifier and woofer business with high value and high performance models.

For the first time, amplifiers can be personalized by the customer with accessories like the POWERCell and FANModule. These accessory components are designed with performance and customization in mind.

If, after reading your manual, you still have questions regarding this product, we recommend that you see your Lightning Audio dealer. If you need further assistance, you can call us direct at 1-800-669-9899. Be sure to have your serial number, model number and date of purchase available when you call.

The serial number can be found on the outside of the box. Please record it in the space provided below as your permanent record. This will serve as verification of your factory warranty and may become useful in recovering your amplifier if it is ever stolen.

Serial Number: _____

Model Number: _____

SPECIFICATIONS

MONO AMPLIFIERS

STORM S1.6000

STORM S1.10000

Number of Channels:	1	1
4 Ohm Power @ 1% THD+N:	300	600
2 Ohm Power @ 1% THD+N:	600	1000
Input Sensitivity:	130mV–3.5V	130mV–3.5V
Power Connector:	LA Power Connector	LA Power Connector
Frequency Response:	10–250Hz	10–250Hz
Subsonic Filter:	Switched	Switched
Signal to Noise Ratio:	90dB	90dB
Crossover LP:	Variable 50–250Hz	Variable 50–250Hz
Crossover Slope:	24dB/Octave	24dB/Octave
Pass Through Output:	Yes	Yes
LA Power Cell Connector:	Yes	Yes
LA Fan Connector:	1 on PC Board	1 on PC Board
LA Lighted Logo Connector:	1 on PC Board	1 on PC Board
Juice Boost EQ @ 45Hz:	0 – +18dB	0 – +18dB

Specifications subject to change without notice

ACCESSORIES

POWERCELL:

All Storm amplifiers can benefit from the addition of the POWERCell, an electrolytic capacitor module that integrates directly to the amplifier through a docking station. The POWERCell delivers big power for transients faster than the vehicle's electrical system. The POWERCell enables the Lightning Audio amplifiers to withstand the rigors of driving 2 ohm loads.



FANMODULE:

Keeping powerful amplifiers cool, especially into lower impedance, is the key function of the FANModule. Easily integrated into the top of the amplifier, the FANModule provides constant cooling over the entire PC board and output devices improving sound quality by reducing distortions caused by thermal gradients.



DESIGN FEATURES

STORM S1.600D

STORM S1.1000D

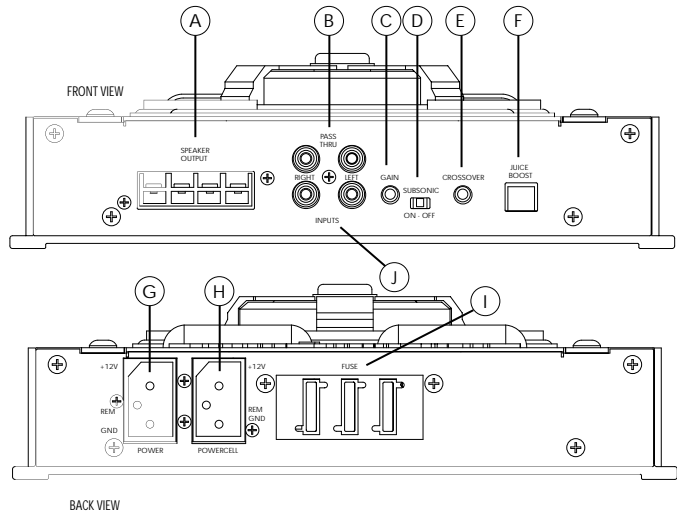
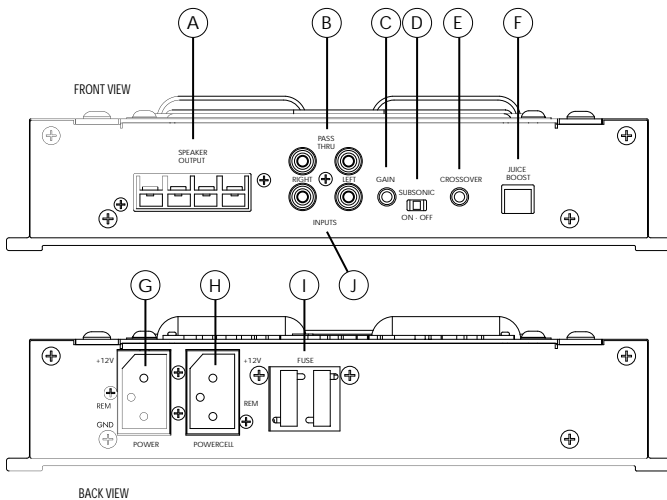

- A. Speaker Connections:** Follow correct polarity, and do not Ground any speaker wires. Do not connect any speaker wires together.
- B. Pass Through Outputs:** The Pass-Thru provides a convenient source for daisy-chaining an additional amplifier without running an extra set of RCA cables from the front of the vehicle to the rear amplifier location.
- C. Gain Control:** The input gain control is preset to match the output of most source units. They can be adjusted to match output levels from a variety of source units.
- D. Sub-Sonic Filter:** Variable from 10-50Hz
- E. Adjustable Crossover Frequency Control:** 50-250Hz.
- F. Juice Boost:** Applies 0-12dB of 50Hz Bass Boost.
- G. Power Connector Plug:** Connects Power, Ground, and Remote
- H. Power Cell (Capacitor) Plug:** Power Cell has 2 active leads for B+ and Ground.
- I. Power Fuse:** If this Fuse should blow, determine the cause or see your authorized dealer. *Never* replace the fuse with one of greater value than the original
- J. RCA Input Jacks – Line Level from Radio Pre-outs:** The industry standard RCA jack provides an easy connection for signal level input. They are gold-plated to resist the signal degradation caused by corrosion.

Not Pictured:

- K. Juice Boost Remote Module:** The Juice Boost remote module has a Green "Operation" indicator and Red "Protection" indicator. The Remote Juice Boost Module allows adjustment of the overall gain or volume of the amplifier. It operates only when the crossover switch is in Low Pass position. It does not alter the frequency response, but instead allows control of the overall gain of the amplifier driving your woofers. Most experienced users adjust the Juice Boost knob on the amp for the maximum desired amount of bass boost, and then plug in the module to control how much of that boost they want to unleash to their subwoofers.

INSTALLATION CONSIDERATIONS

The following is a list of tools you will need for installing the Lightning Audio:

Adequate Length	Voltmeter
Wire strippers	Battery post wrench
Electric hand drill w/assorted bits	Wire cutters
Adequate Length—Red Power Wire	Assorted connectors
Adequate Length—Remote Turn-on Wire	Wire crimpers
Adequate Length—Black Grounding Wire	

This section focuses on some of the vehicle considerations for installing your new Lightning Audio amplifier. Checking your battery and present sound system, as well as pre-planning your system layout and best wiring routes will save installation time. When deciding how to lay out your new system, be sure that each component will be easily accessible for making adjustments.

Before beginning any installation, be sure to follow these simple rules:

1. Be sure to carefully read and understand the instructions before attempting to install the amplifier.
2. **For safety**, disconnect the negative lead from the battery prior to beginning the installation.
3. For easier assembly, we suggest you run all wires prior to mounting your amplifier in place.
4. Route all of the RCA cables close together and away from any high current wires.
5. Use high quality connectors for a reliable installation and to minimize signal or power loss.
6. **Think before you drill!** Be careful not to cut or drill into gas tanks, fuel lines, brake or hydraulic lines, vacuum lines or electrical wiring when working on any vehicle.
7. Never run wires underneath the vehicle. Running the wires inside the vehicle provides the best protection.
8. Avoid running wires over or through sharp edges. Use rubber or plastic grommets to protect any wires routed through metal, especially the firewall.
9. **ALWAYS** protect the battery and electrical system from damage with proper fusing. Install a fuseholder and appropriate fuse on the +12V power wire within 18" (45.7 cm) of the battery terminal.
10. When grounding to the chassis of the vehicle, scrape all paint from the metal to ensure a good, clean ground connection. Grounding connections should be as short as possible and always be connected to metal that is welded to the main body, or chassis, of the vehicle.



Improper wiring connections can seriously damage the Amplifier and your vehicle. Be sure to carefully follow the connection instructions in this manual.
Note: If you are unsure of the connections, contact your dealer.

MOUNTING LOCATIONS

The mounting location and position of your amplifier will have a great effect on its ability to dissipate the heat generated during normal operation. To maximize the performance of your amplifier, care should be taken to ensure adequate ventilation.

Trunk Mounting

Mount the amplifier vertically; this will provide the best cooling of the amplifier.

Mounting the amplifier on the floor of the trunk will work but provides less cooling capability than vertical mounting.

Mounting the amplifier upside down to the rear deck of the trunk will not provide proper cooling and will severely affect the performance of the amplifier and is strongly **not** recommended.

Passenger Compartment Mounting

Mounting the amplifier in the passenger compartment will work as long as you provide a sufficient amount of air for the amplifier to cool itself. If you are going to mount the amplifier under the seat of the vehicle, you must have at least 1" (2.54cm) of air gap around the amplifier's heatsink.

Mounting the amplifier with less than 1" (2.54cm) of air gap around the amplifier's heatsink in the passenger compartment will not provide proper cooling and will severely affect the performance of the amplifier and is strongly **not** recommended.

Engine Compartment Mounting

Lightning Audio amplifiers should **never** be mounted in the engine compartment. Not only will this void your warranty but could create an embarrassing situation caused by the ridicule from your friends.

BATTERY AND CHARGING

Amplifiers will put an increased load on the vehicle's battery and charging system. We recommend checking your alternator and battery condition to ensure that the electrical system has enough capacity to handle the increased load of your stereo system. Stock electrical systems which are in good condition should be able to handle the extra load of any Lightning Audio amplifier without problems, although battery and alternator life can be reduced slightly. To maximize the performance of your Lightning Audio amplifier, we suggest the use of a heavy duty battery and an energy storage capacitor.

WIRING THE SYSTEM

CAUTION: *Avoid running power wires near the low level input cables, antenna, power leads, sensitive equipment or harnesses. The power wires carry substantial current and could induce noise into the audio system.*

• **For safety**, disconnect the negative lead from the battery prior to beginning the installation.

1. Plan the wire routing. Take care when running signal level RCA cables to keep them close together but isolated from the amplifier's power cables and any high power auto accessories, especially electric motors. This is done to prevent coupling the noise from radiated electrical fields into the audio signal. When feeding the wires through the firewall or any metal barrier, protect them with plastic or rubber grommets to prevent short circuits. Leave the wires long at this point to adjust for a precise fit at a later time.
2. Prepare the **Power** cable for attachment to the amplifier by stripping 1/2" of insulation from the end of the wire. Insert the bared wire into the B+ terminal and tighten the set screw to secure the cable in place.

NOTE: *The B+ cable MUST be fused 18" or less from the vehicle's battery. Install the fuseholder under the hood and prepare the cable ends as stated above. Connections should be water tight.*

Trim the power cable within 18" of the battery and strip 1/2" of insulation from the end of the wire. **Cut the wire loop that is attached to the fuseholder in half and splice the fuse into the power line using appropriate inline connectors.** Use the section of cable that was trimmed earlier and connect it to the other end of the fuseholder.

3. Strip 1/2" from the battery end of the power cable and crimp a large ring terminal to the cable. Use the ring terminal to connect to the battery positive terminal. **Do not install the fuse at this time.**
4. Prepare the **Ground** cable for attachment to the amplifier by stripping 1/2" of insulation from the end of the wire. Insert the bared wire into the GND terminal and tighten the set screw to secure the cable in place. Prepare the chassis ground by scraping any paint from the metal surface and thoroughly clean the area of all dirt and grease. Strip the other end of the wire and attach a ring connector. Fasten the cable to the chassis using a non-anodized screw and a star washer.
5. Prepare the **REM** turn-on wire for connection to the amplifier by stripping 1/2" of insulation from the wire end. Insert the bared wire into the REM terminal and tighten the set screw to secure the cable into place. Connect the other end of the REM wire to a switched 12 volt positive source. The switched voltage is usually taken from the source unit's auto antenna or the accessory lead. If the source unit does not have these outputs available, the recommended solution is to wire a mechanical switch in line with a 12 volt source to activate the amplifier.
6. Securely mount the amplifier to the vehicle or amp rack. Be careful not to mount the amplifier on cardboard or plastic panels. Doing so may enable the screws to pull out from the panel due to road vibration or sudden vehicle stops.
7. Connect the source signal to the amplifier by plugging the RCA cables/high level inputs into the input jacks at the amplifier.
8. Connect the speakers. Strip the speaker wires 1/2" and insert into the speaker terminal and tighten the set screw to secure into place. Be sure to maintain proper speaker polarity. **DO NOT chassis ground any of the speaker leads as unstable operation may result.**
9. Perform a final check of the completed system wiring to ensure that all connections are accurate. Check all power and ground connections for frayed wires and loose connections which could cause problems.

USING PASSIVE CROSSOVERS

A passive crossover is a circuit that uses capacitors and/or coils and is placed on speaker leads between the amplifier and speaker. The crossover delegates a specific range of frequencies to the speaker for optimum driver performance. A crossover network can perform one of three functions: High-Pass (capacitors), Low-Pass (inductors or coils) and Bandpass (combination of capacitor and coil).

The most commonly used passive crossover networks are 6dB/octave systems. These are easy to construct and require one component per filter. Placing this filter in series with the circuit will reduce power to the speaker by 6dB/octave above or below the crossover point depending on whether it is a high-pass or low-pass filter. More complex systems such as 12dB/octave or 18dB/octave can cause impedance problems if not professionally designed.

Passive crossovers are directly dependent upon the speaker's impedance and component value for accuracy. When passive crossover components are used in multiple speaker systems, the crossover's effect on the overall impedance should be taken into consideration along with the speaker's impedance when determining amplifier loads. **CAUTION: The Lightning Audio amplifiers are not recommended for impedance loads below 2Ω stereo and 4Ω bridged (mono) loads.**

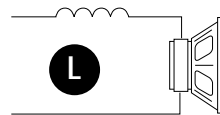

6dB/Octave Low-Pass

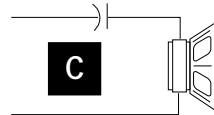

6dB/Octave High-Pass

Freq. Hertz	Speaker Impedance					
	2 OHMS		4 OHMS		8 OHMS	
	L	C	L	C	L	C
80	4.1mH	1000mF	8.2mH	500mF	16mH	250mF
100	3.1mH	800mF	6.2mH	400mF	12mH	200mF
130	2.4mH	600mF	4.7mH	300mF	10mH	150mF
200	1.6mH	400mF	3.3mH	200mF	6.8mH	100mF
260	1.2mH	300mF	2.4mH	150mF	4.7mH	75mF
400	.8mH	200mF	1.6mH	100mF	3.3mH	50mF
600	.5mH	136mF	1.0mH	68mF	2.0mH	33mF
800	.41mH	100mF	.82mH	50mF	1.6mH	26mF
1000	.31mH	78mF	.62mH	39mF	1.2mH	20mF
1200	.25mH	66mF	.51mH	33mF	1.0mH	16mF
1800	.16mH	44mF	.33mH	22mF	.68mH	10mF
4000	.08mH	20mF	.16mH	10mF	.33mH	5mF
6000	51mH	14mF	.10mH	6.8mF	.20mH	3.3mF
9000	34mH	9.5mF	68mH	4.7mF	.15mH	2.2mF
12000	25mH	6.6mF	51mH	3.3mF	100mH	1.6mF

L = Low-Pass (Inductor)
C = High-Pass (Capacitor)

For more information, see your Authorized Lightning Audio Dealer.

INSTALLATION

- For safety, disconnect the negative lead from the car battery prior to beginning the installation

Trunk Mounting

Mounting the amplifier vertically on a surface will provide the best cooling for the amplifier.

Passenger Compartment Mounting

Mounting the amplifier in the passenger compartment will work as long as you provide a sufficient amount of air for the amplifier to cool itself. If you are going to mount the amplifier under the seat of the vehicle, you must have at least 1" (2.54cm) of air gap around the amplifier's heatsink.

B+ Terminal

The B+ cable MUST be fused 18" (45cm) or less from the vehicle's battery. Prepare the cable ends and install the fuse-holder under the hood. Connections should be water tight.

GND Terminal

Prepare a length of cable to be used for the ground connection. Prepare the chassis ground by scraping any paint from the metal surface and thoroughly clean the area of all dirt and grease. Fasten the cable to the chassis using a screw.

REM Terminal

Connect the REM wire to a switched 12 volt positive source. The switched signal is usually taken from the source unit's auto antenna or the accessory lead. If the source unit does not have these outputs available, the recommended solution is to wire a mechanical switch in-line with a 12 volt source to activate the amplifier.

Input Connectors

Follow the diagram and connect the appropriate signal cables to the input terminals of the amplifier. Be sure that the signal cables are routed close together and away from any high current wires.

Speaker Output Terminals

Connect the speaker system to the amplifier by inserting the wires into the corresponding output terminals and tighten the set screws. Follow the diagram for proper signal polarity. **DO NOT chassis ground any of the speaker wires as unstable amplifier operation may result. CAUTION: This amplifier is not recommended for impedance loads below 2W stereo and/or 4W bridged (mono).**

Gain Control(s)

The amplifier is factory set for optimum dynamic range. The system levels may be adjusted by ear when using a source unit with higher or lower output levels by using the following procedure.

1. Turn the gain control to minimum (counterclockwise)
2. Play a music track with high dynamic content and turn up the source unit to at least 3/4 volume
3. Slowly increase the gain and set it just below audible distortion or until reaching a comfortable hearing threshold (whichever occurs first)

TROUBLESHOOTING

Symptom	Diagnosis	Remedy
Amplifier does not turn on.	B+ or REM not between 10.5 and 15.5 volts or no voltage present	Check the alternator, battery, fuse, and wiring and repair as necessary
	Amplifier is not properly grounded.	Check wiring and repair as necessary
Amplifier Noise (Turn-On Pop)	Voltage spike from source unit is entering amplifier's input	Connect turn-on module to REM terminal if pops are eliminated with no input signal to amplifier
Engine Noise	Noise is radiating into signal cables	Re-route signal cables away from sources of high current

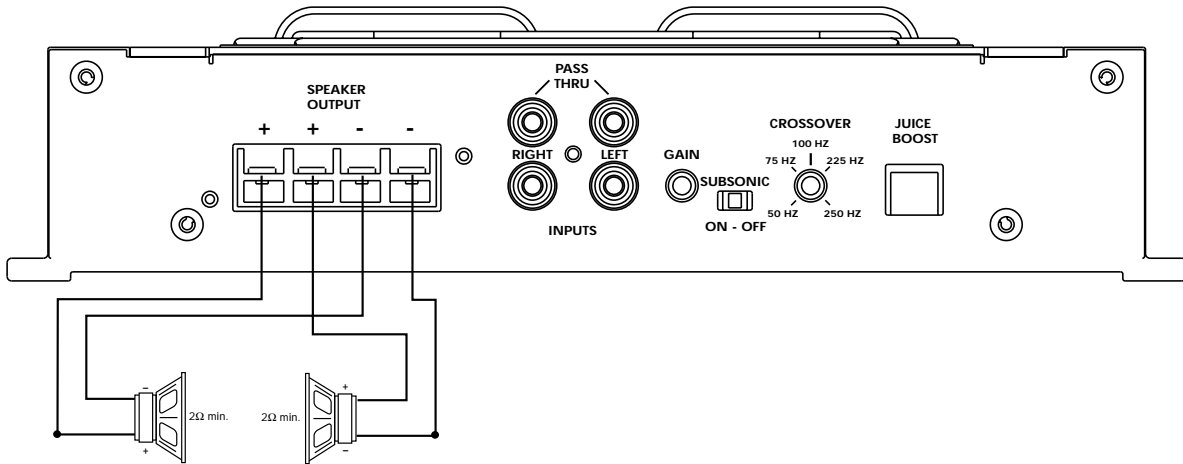

- **RCA** inputs are connected to *both left and right* channels.
- **Impedance** for mono channel should be 2Ω *minimum*.

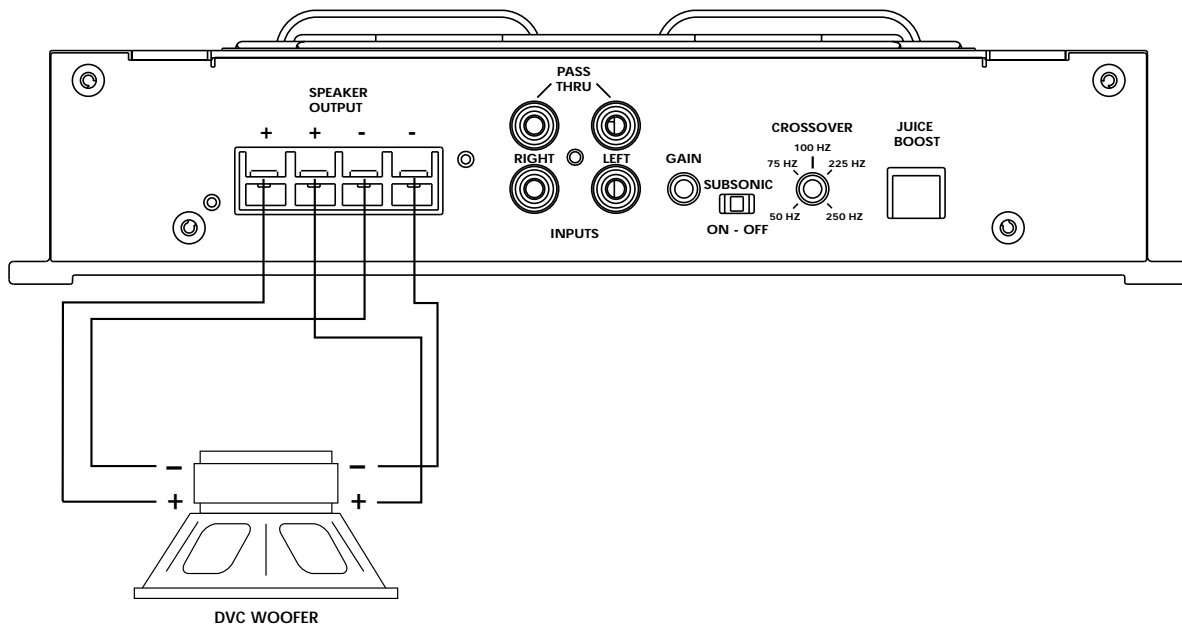

SYSTEM DIAGRAMS

3 - WAY SYSTEM USING SINGLE VOICE COIL WOOFERS

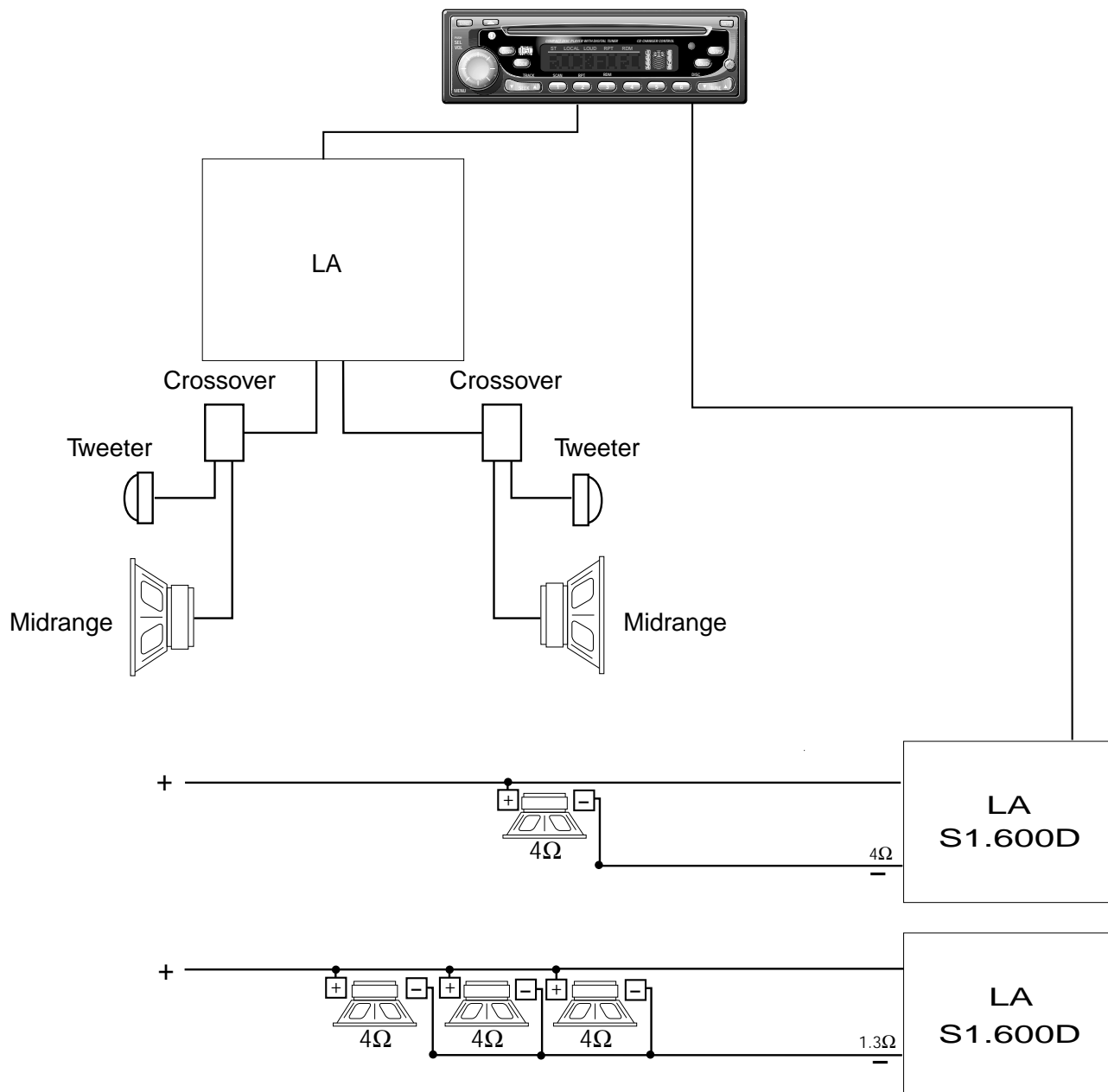

SYSTEM DIAGRAMS

3-WAY SYSTEM USING DUAL VOICE COIL WOOFERS

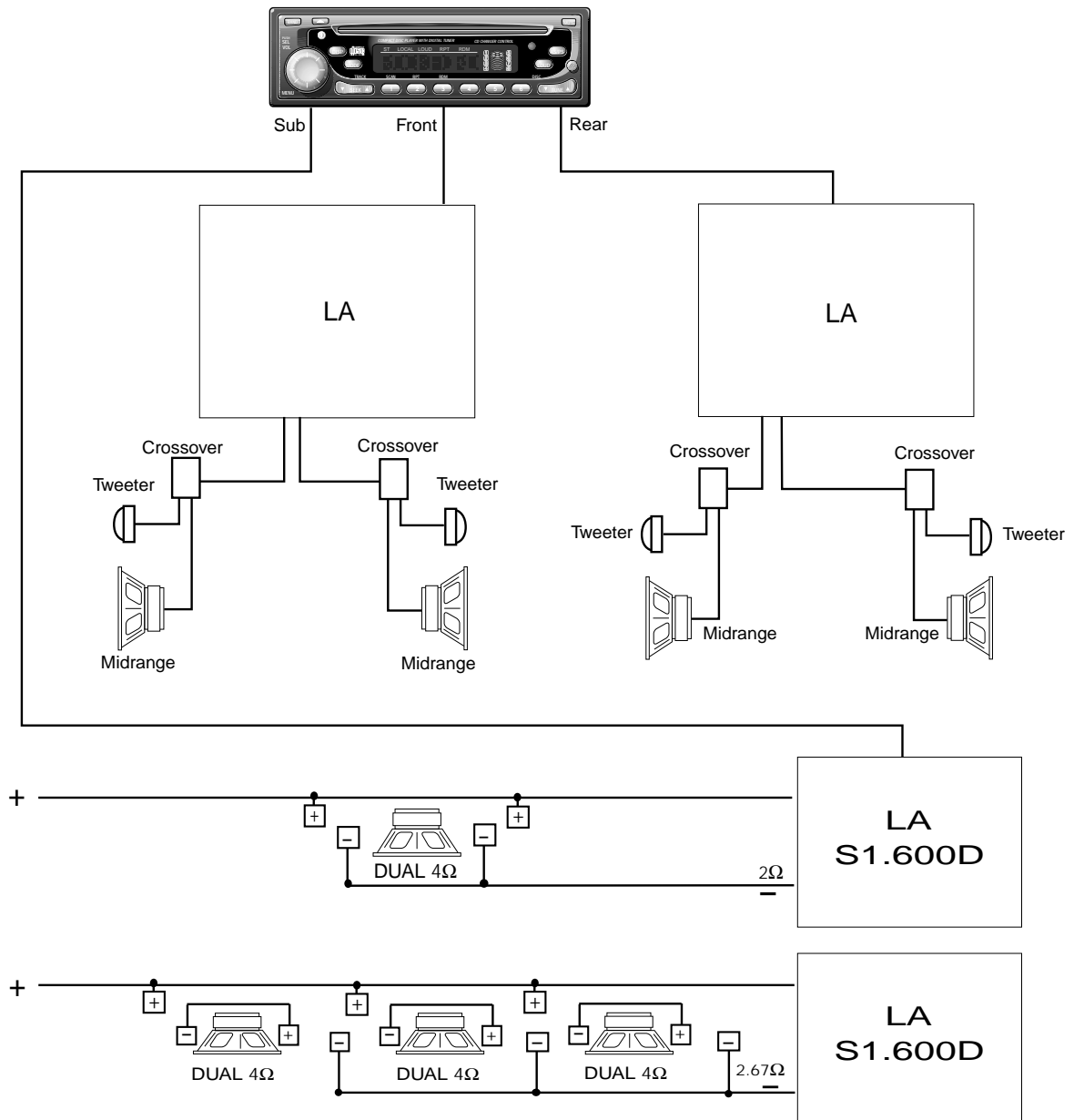

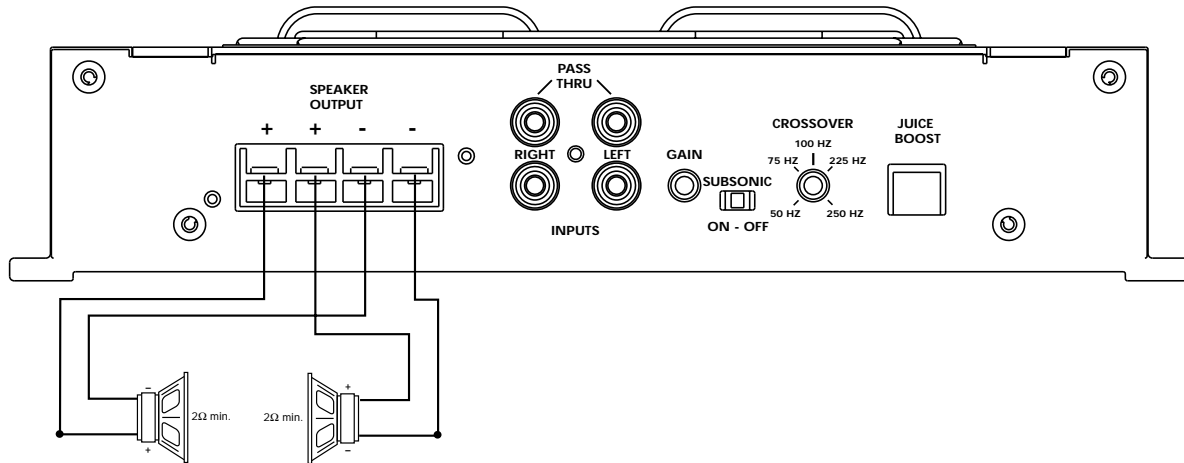

- Las entradas **RCA** se conectan a ambos *canales izquierdo y derecho*
- La **impedancia** minima mono debe ser 2Ω .

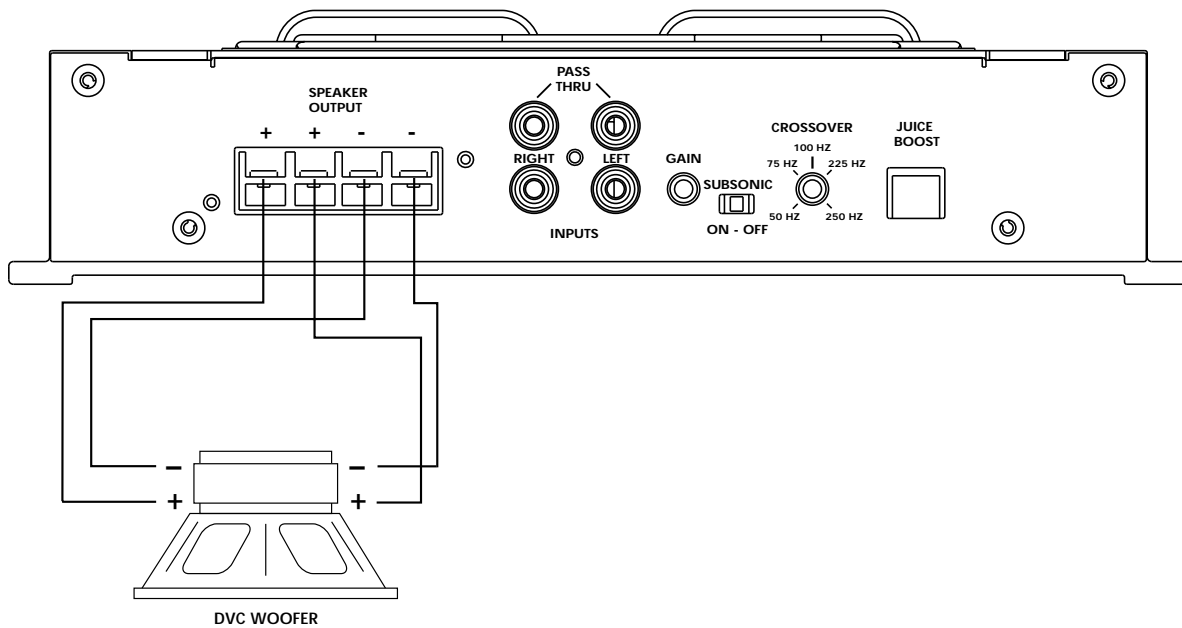

- Por seguridad, desconecte el terminal negativo de la batería antes de comenzar la instalación.

Montaje en el Malatero del vehículo

Monte el amplificador verticalmente con las orientadas de arriba hacia abajo. De esta manera conseguirá la mejor ventilación.

Montaje en el Compartimento de Pasajeros

El montaje en el compartimento de pasajeros sera eficiente en funcion de la ventilación que tenga el amplificador. Si va a instalar el amplificador bajo un asiento deberá dejar al menos 2.5cm libres sobre la carcasa del amplificador.

Terminal B+

El cable B+ debe ir provisto de un fusible a una distancia no mayor de 45cm de la batería. Prepare el cable e instale el portafusibles en el compartimento del motor. Las conexiones han de ser impermeables.

Terminal GND

Prepare un trozo de cable para usarlo como toma de masa. Prepare un punto de masa en el chasis rascando y eliminando la pintura de la superficie de metal y límpielo de toda suciedad asegure el cable al chasis con un tornillo.

Terminal REM (Encendido remoto)

Conecte el cable REM a un punto de +12V conmutable. La señal se suele coger de la salida auto antena del radio cassette si este no tiene salida remote.

Conectores de Entrada

Siga el diagrama y conecte los cables adecuados para señal a los terminales de entrada del amplificador. Asegúrese que los cables de señal estén canalizados en conjunto y lo más lejos posible de cualquier cable de alto amperaje.

Terminales de salida para los Parlantes

Conecte el sistema de parlantes al amplificador insertando los cables correspondientes en los terminales de salida y luego aprete los tornillos. Siga el diagrama para una adecuada polaridad de señal. **NO CONECTE ninguno de los cables de los parlantes a la masa de la carcasa, ya que esto puede resultar en una operación inestable del amplificador. PRECAUCION: este amplificador no está recomendado para cargas de impedancia por abajo de 2 Ohmios en estéreo y/ó 4 Ohmios en modo puente (bridge mono).**

Control(es) de Ganancia

El amplificador está dispuesto desde la fábrica para óptimo rango dinámico. Los niveles del sistema pueden ser ajustado por oído cuando se utilice una unidad fuente con niveles de salidas más altos ó bajos, mediante el uso del siguiente procedimiento:

1. Lleve el control de ganancia al mínimo (en contra de las agujas del reloj)
2. Reproduzca una pista musical con alto contenido dinámico y lleve el volumen de la unidad fuente hasta unos 3/4 de máximo
3. Lentamente incremente la ganancia y pare justo bajo el nivel audible de distorsion ó hasta que llegue a un umbral agradable de audición (cualquiera que ocurra primero)

TROUBLESHOOTING

Síntoma	Diagnóstico	Remedio Reparación
El Amplificador no enciende	B+ ó REM no están entre 10.5 y 15.5 voltios ó no hay voltaje presente.	Chequee el alternador, batería, fusible y cableado y repare según sea necesario
	El amplificador no está aterrado apropiadamente	Cheque el cableado y repare según sea necesario
Ruido de Amplificador (Popeo de encendido)	Picos de voltaje de la unidad fuente están presentes en la entrada del amplificador	Conecte el módulo de encendido al terminal REM si el popeo es eliminado cuando el amplificador no tiene señal de entrada
Ruido de Motor	Ruido está siendo radiado en los cables de señal	Recanalizar los cables de señal alejado de fuentes de alto amperaje

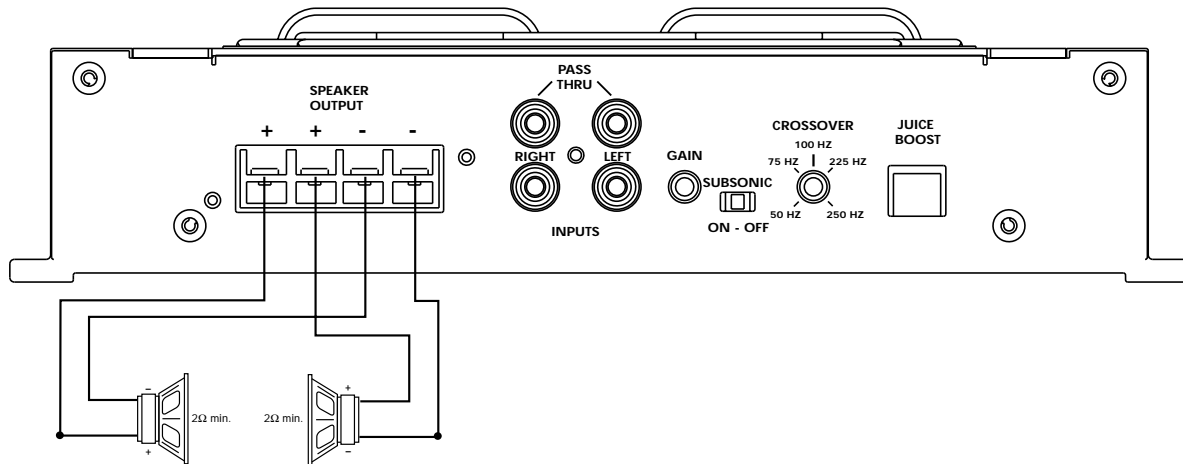

- Les entrées **RCA** sont connectées aux canaux gauche et droit
- L'**impédance** du canal mono devrait être de minimum 2Ω

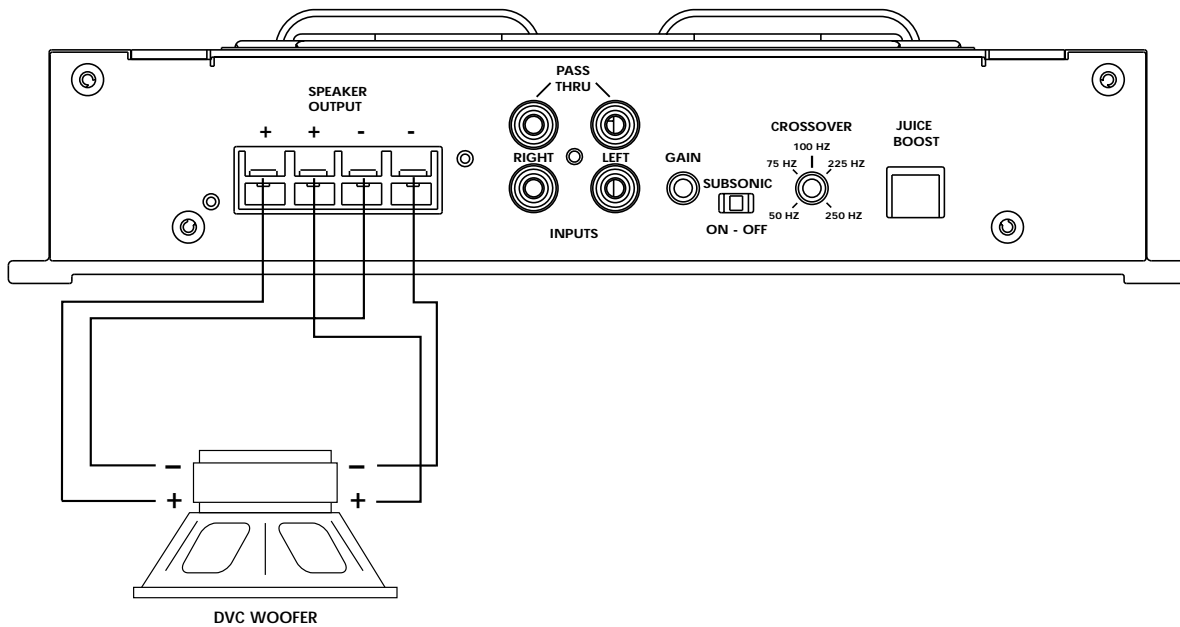

INSTALLATION

- Pour votre sécurité, déconnectez la borne négative de la batterie du véhicule avant de commencer le montage.

Montage dans l'habitacle

L'installation d'un amplificateur est envisageable dans l'habitacle dès que la convection naturelle est suffisante. Il est possible de fixer l'amplificateur sous un siège si la hauteur de celui-ci permet au minimum d'avoir trois centimètres au-dessus du dissipateur thermique.

Alimentation

La connexion B doit être reliée impérativement via un fusible, directement à la borne positive de la batterie.

La connexion GND

Cette liaison référence l'amplificateur à la masse. La masse électrique du châssis n'a pas en tous points la même qualité. Il vous sera utile de recourir aux compétences d'un professionnel pour déterminer le meilleur point. Une fois trouvé, il faudra débarrasser la tôle de toutes traces de peinture, le raccordement devra se faire par une vis acier (sans traitement de surface).

La connexion REM

Cette connexion est la commande à distance de mise en/hors service. Elle est généralement reliée à la sortie (antenne électrique de l'autoradio) ou auprès d'une source de douze volts commutée.

Connecteur CINCH

Cette liaison assure la transmission de modulation entre l'autoradio et la source. En raison des faibles signaux véhiculés dans ces câbles, ceux-ci devront être tenus à l'écart du faisceau électrique du véhicule et des câbles d'alimentation de l'amplificateur.

Connections haut-parleurs

Les haut-parleurs seront connectés sur cette partie du bornier. Soyez vigilant quant au sens du branchement + et -. Avertissement: L'impédance globale en mode stéréo ne peut être inférieure à deux W et en mode ponté à quatre W.

Contrôle de sensibilité

A la sortie d'usine, l'amplificateur est réglé (valeur qui détermine la meilleure capacité dynamique). La sensibilité est variable pour adapter l'amplificateur aux différentes sources qui ne possèdent pas le même niveau de sortie. Ce réglage est très important, il est déterminant de la qualité de reproduction et de la pérennité de l'installation.

Méthodologie du réglage

1. Positionnez le réglage de sensibilité au minimum (à l'inverse du sens des aiguilles d'une montre)
2. Ecoutez un passage musical à grande dynamique (solo de guitare basse, etc.) avec le potentiomètre de volume de la source au 3/4
3. Doucement dans le sens des aiguilles d'une montre tournez le potentiomètre de sensibilité de l'amplificateur jusqu'à percevoir une déformation. A cette étape, il faut revenir juste en-dehors du seuil de déformation
4. Il faut répéter plusieurs fois cette procédure avec différents disques pour être sûr du réglage

SOLUTIONS AUX PROBLÈMES

Symptôme	Diagnostic	Solution
L'amplificateur ne fonctionne pas	B+ ou REM ne sont pas connectés à une source de 12V	Vérifiez si la batterie est reconnectée et si le fusible est bon
Bruit à l'a mise en/hors service	Le bruit est transmis par la source	Insérez un module séparé de télécommande commandant l'amplificateur
Bruit parasite	Bruit rayonné sur les câbles de modulation	Tenir à l'écart les câbles de modulation du faisceau électrique de la voiture et de l'alimentation de l'amplificateur

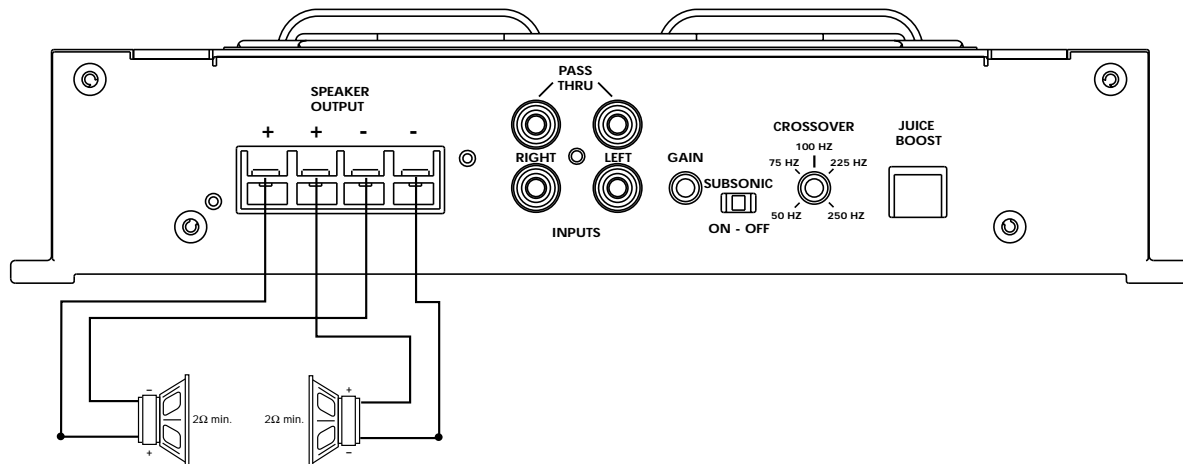

- Chinch Eingänge des *rechten- und linken-Kanales* anschließen
- **Die Impedanz** des Mono Kanales sollte *minimum 2 Ohm* betragen

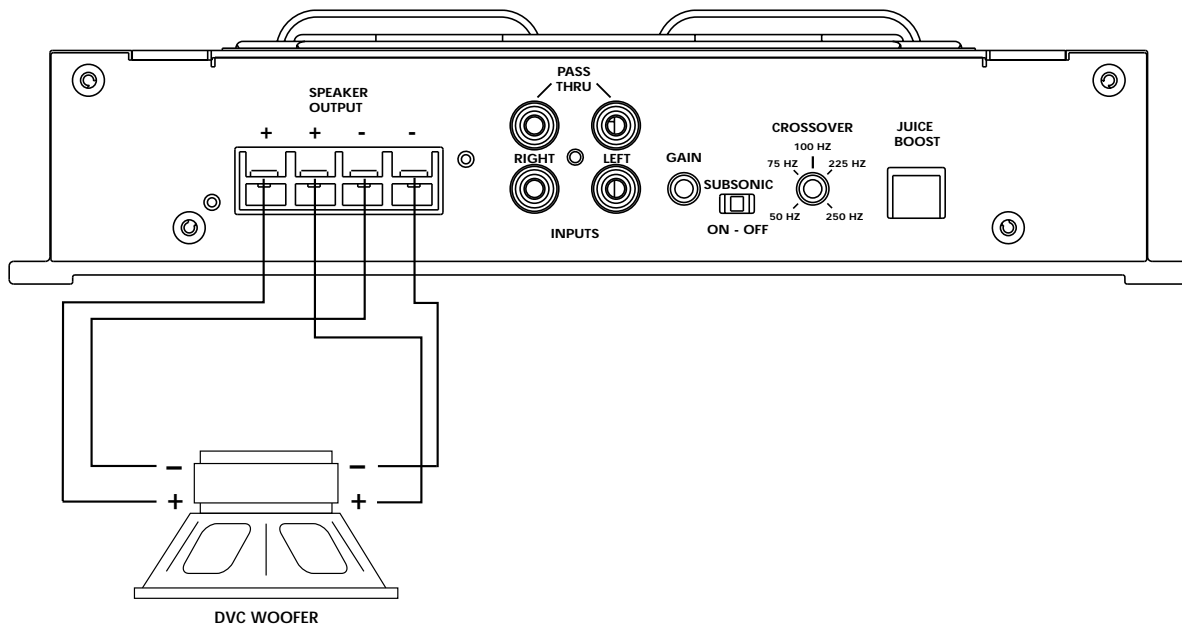

- Zur Sicherheit klemmen Sie den **Negativ-Pol der Batterie während des gesamten Einbaues ab.**

Im Fahrzeugkofferraum

Der vertikale Einbau der Endstufen, gibt dem Verstärker die beste Kühlung.

Auf der Beifahrerseite

Sollte der Verstärker auf der Beifahrerseite montiert werden, so ist es sehr wichtig für eine ausreichende Kühlung zu sorgen. Sollte der Verstärker z.B. unter dem Beifahrersitz montiert werden, sollte dem Kühlkörper mindestens ein Luftspalt von 3 cm bleiben, um so für eine ausreichende Kühlung zu sorgen.

B+ Anschluss

Die Plus-Leitung MUB ca. 40 cm nach dem Plus-Pol der Batterie abgesichert sein. Preparieren Si die Kabellängen und montieren Sie den Sicherungshalter im Motorraum. ALLE Verbindungen müssen wasserdicht sein.

GND Anschluss

Preparieren Sie Ihr Kabel für Negativ Leitung (Erdung). Preparieren Sie die Anschlussstelle des Erdungskabels, indem Sie das Metall gründlich reinigen und vom Lack befreien. Befestigen Sie nun die Erdung an dieser Stelle mit einer Schraube.

REM Anschluss

Verbinden Sie das Ein- und Ausschaltungskontroll-Kabel mit Ihrem Radio (12 Volt positiv). Normalerweise verwenden Sie hierfür die Ant.-Remote). Sollte Ihr Radio diesen Anschluss nicht besitzen, so verwenden Sie eine 12 Volt Spannung, die Sie durch einen Schalter ein- und ausschalten können.

Eingangs-Anschlüsse

Beachten Sie den Anschlussplan und verbinden Sie die Signalkabel mit den Eingangs-Anschlüssen des Verstärkers. Seien Sie sicher, dass die Kabel dicht zusammen und entfernt von stromführenden Kabeln liegen.

Lautsprecher Ausgänge

Verbinden Sie das Lautsprechersystem mit dem Verstärker, indem Sie die Kabel in die entsprechenden Anschlüsse stecken und verschrauben. Beachten Sie hierbei den Anschlussplan, um eine korrekte Polarität zu gewährleisten. **Erden Sie niemals eine der Lautsprecherleitung auf die Masse des Fahrzeuges. Achtung: Die minimale Last von 2W Stereo und/oder 4W gebreuekt (Mono) darf nicht unterschritten werden.**

Eingangsempfindlichkeit

Der Verstärker ist Werksseitig auf eine Eingangsspannung. Die Eingangsempfindlichkeit kann nach Gehör verstellt werden, wenn die Ausgangsspannung des Steuergerätes höher oder niedriger ist. Gehen Sie wie folgt vor.

1. Drehen Sie die Eingangsempfindlichkeit auf ein Minimum (gegen den Uhrzeigersinn).
2. Speilen Sie einen Musiktitel mit einer sehr hohen Dynamik und drehen Sie die Lautstärkekontrolle des Steuergerätes auf ä der Maximallautstärke.
3. Jetzt verstellen Sie die Eingangsempfindlichkeit des Verstärkers soweit (im Uhrzeigersinn drehen), bis Sie eine Verzerrung des Signals wahrnehmen. Danach sollte ie Empfindlichkeit wieder soweit zurueck gedreht werden (gegen den Uhrzeigersinn), bis die Verzerrungen verschwindern.

FEHLERSUCHE

Symptom	Diagnose	Fehlerbehebung
Verstärker schaltet nicht ein	Die B+ oder Rem. Spannung liegt nicht zwischen 10.5 und 15.5 Volt	Kontrollieren Sie die Lichtmaschine, Batterie, Sicherung und die Kable. Reparieren Sie diese, wenn noetig
	Verstärker ist nicht korrekt geerdet	Kontrollieren Sie die Kabel und reparieren Sie diese, wenn noetig
Verstärker Einschaltgeräusch (Turn-On Pop)	Die XCard ist falsch oder gar nicht in den entsprechenden Socket gesteckt.	Kontrollieren Sie die Installation der XCard und ändern Sie diese, wenn noetig
Lichtmaschinen Summen	Stoerungen strahlen in die Signalkabel	Verlegen Sie die Kabel weit entfernt von stromfuehr

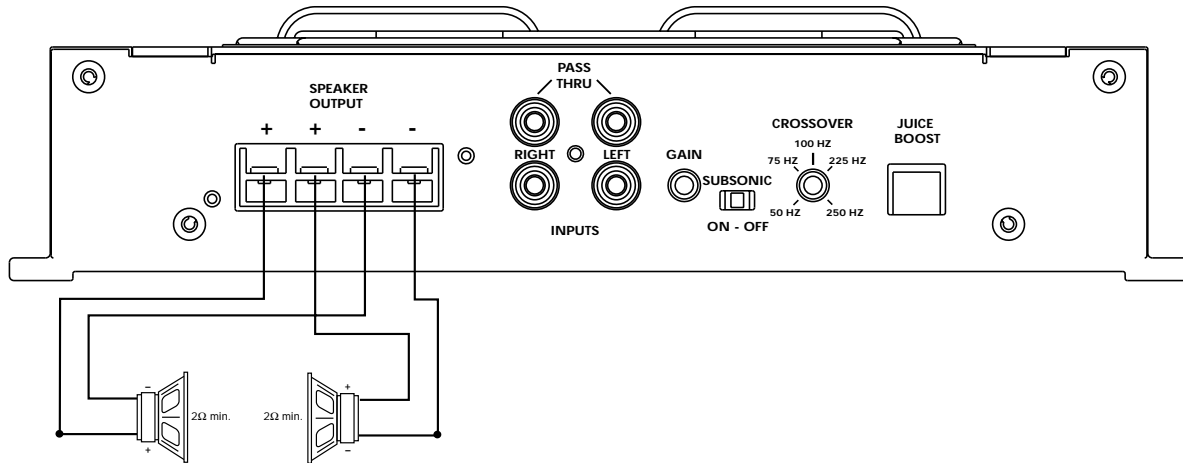

- Ingressi **RCA** collegati sia al canale destro sia al sinistro
- L'**impedenza** per il canale mono deve essere minimo 2Ω

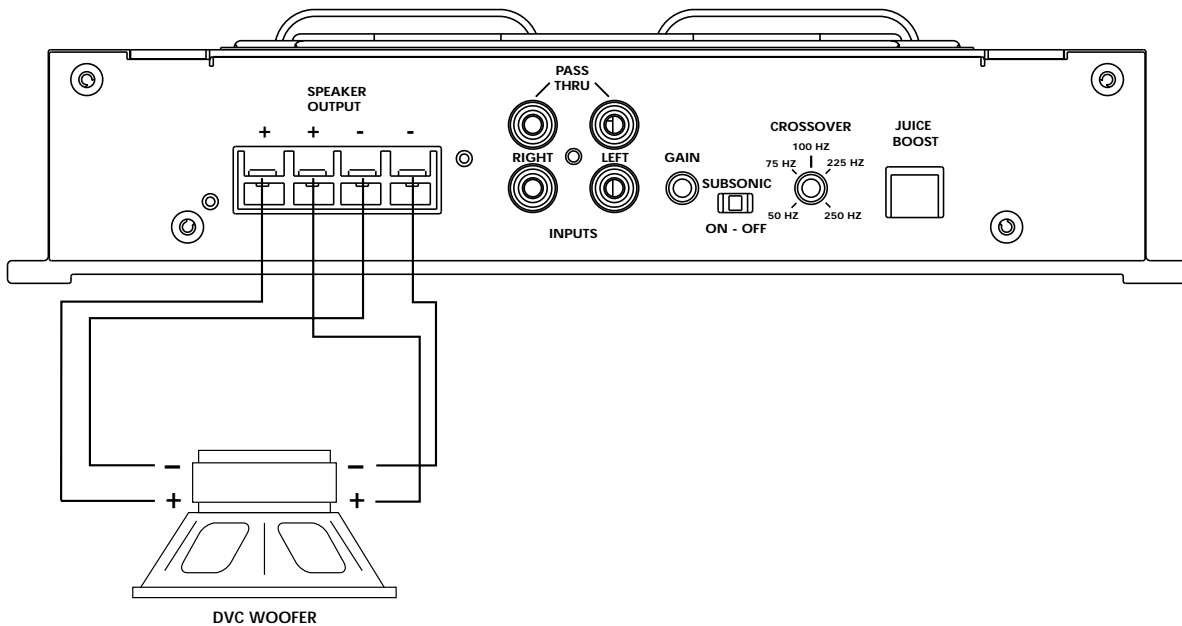

INSTALLAZIONE

- Per sicurezza, scollegare il polo negativo della batteria dell'auto prima di iniziare l'installazione.

Nel Bagagliaio

Montando l'amplificatore su una superficie in verticale con le alette direzionate dall'alto verso il basso si garantirá un miglior raffreddamento dell'amplificatore.

Nel'abitacolo

Montare l'amplificatore nell'abitacolo si avrá un funzionamento regolare se si garantisce un flusso d'aria sufficiente. Per l'installazione sotto un sedile, é necessario avere uno spazio di almeno 3 cm attorno a tutto l'amplificatore.

Terminale B+ (cavo positivo)

Il cavo positivo deve essere protetto da un fusibile a non piú di 45 cm dalla batteria. Terminare il cavo e installare il fusibile nel vano motore. Tutte le connessioni devono essere a prova d'acqua.

Terminal GND (cavo negativo)

Decidere la lunghezza del cavo e terminarlo. Preparare la massa grattando la vernice dal telaio dell'auto ed eliminando tracce di olio o sporco. Fissare il cavo di massa al telaio con una vite.

Terminal REM (Consenso di accensione)

Collegare il cavo REM ad un positivo present solo ad autoradio accessa (normalmente il cavo pilota dell'antenna elettrica o il cavo accessori dell'autoradio). Se la sorgente non dovesse essere equipaggiata con queste uscite, la soluzione raccomandabile é di inserire un interruttore su un cavo positivo e connettersi all'amplificatore.

Connettori di ingresso

Seguendo lo schema collegate i cavi di segnale agli appropriati terminali di ingresso dell'amplificatore. Assicuratevi che i cavi di segnale siano passati vicini tra loro e lontano da cavi ad alta corrente.

Connettori degli altoparlanti

Collegate il sistema di altoparlanti inserendo i cavi nei terminali corrispondenti e serrate le viti. Seguite lo schema per l'ottimale collegamento delle polaritá. **Non cortocircuitate a massa nessun cavo degli altoparlanti, potrebbe verificarsi un anomalo comportamento dell'amplificatore. ATTENZIONE; questo amplificatore non é raccomandato per impedenze inferiori ai 2 ohm stereo w/o 4 ohm mono a ponte.**

Controlli della sensibilità

L'amplificatore é regolato dalla casa per un ottimale rendimento dinamico. Il livello di ingresso puó essere regolato anche ad orecchio quando si impiega una sorgente con uscita superiore od inferiore. Seguite questa procedure:

1. Portate il controllo della sensibilità al minimo (senso antiorario)
2. Suonate un brano musicale con elevato contenuto dinamico portando il volume della sorgente a circa 3/4
3. Aumentate lentamente il livello di ingresso dell'amplificatore e posizionate subito prima dell'insorgere di distorsione o quando il livello generale vi appaia confortevole

RISOLUZIONE DEI PROBLEMI

Sintomo	Diagnosi	Rimedio
L'amplificatore non si accende	Il B+ o il REM non hanno una tensione compresa tra i 10,5 e 15,5 volt o nessuna tensione é presente	Verificate l'alternatore, la batteria, i fusibili, il cablaggio e riparate quanto necessario
	L'amplificatore non é correttamente a massa	Controllate il cablaggio e riparate se necessario
Rumore dell'amplificatore (bump di accensione)	Picchi di tensione provenienti dalla sorgente entrano dall'ingresso dell'amplificatore	Se il bump si elimina disconnettendo gli ingressi, collegate un modulo di accensione
Rumore dal motore	Il rumore si propaga nei cavi di segnale	Ritendete i cavi di segnale lontano da cavi ad alta corrente



ENGLISH

Please contact your local Authorized Lightning Audio Dealer for information on Warranty Policies and Technical Support.

ESPAÑOL

Por favor contacte al Distribuidor Autorizado Lightning Audio en su localidad para información sobre Políticas de Garantía Soporte Técnico.

FRANÇAIS

Veillez contacter votre distributeur Lightning Audio agréé pour toute information concernant les modalités de garantie et le support technique.

DEUTSCH

Bitte Fragen Sie Ihren autorisierten Lightning Audio Händler über Informationen, die die Garantie oder technische Probleme betreffen.

ITALIANO

Contattate il vostro rivenditore autorizzato Lightning Audio per informazioni sulle condizioni di garanzia e per il supporto tecnico.

LIMITED WARRANTY INFORMATION

Lightning Audio offers a limited warranty on products on the following terms:

- **Length of Warranty**

- **Speakers**

- One year parts and labor warranty. Requires proof of purchase

- **Amplifiers**

- If installed by an authorized Lightning Audio dealer, two years parts and labor, requires proof of purchase/ installation. If purchased from authorized dealer and installed by a third party, one year parts and labor. Requires proof of purchase.

- **PC1, FM1, CT1**

- One year parts and labor. Requires proof of purchase.

- **What is Covered**

This warranty applies only to Lightning Audio products sold to consumers by Authorized Lightning Audio Dealers in the United States of America or its possessions. Product purchased by consumers from an Authorized Lightning Audio Dealer in another country are covered only by that country's Distributor and not by Lightning Audio.

- **Who is Covered**

This warranty covers only the original purchaser of Lightning Audio product purchased from an Authorized Lightning Audio Dealer in the United States. In order to receive service, the purchaser must provide Lightning Audio with a copy of the receipt stating the customer name, dealer name, product purchased and date of purchase.

- **Products found to be defective** during the warranty period will be repaired or replaced (with a product deemed to be equivalent) at Lightning Audio's discretion.

- **What is Not Covered**

1. Damage caused by accident, abuse, improper operations, water, theft
2. Any cost or expense related to the removal or reinstallation of product
3. Service performed by anyone other than Lightning Audio or an Authorized Lightning Audio Service Center
4. Any product which has had the serial number defaced, altered, or removed
5. Subsequent damage to other components.
6. Any product purchased outside the U.S.
7. Any product not purchased from an Authorized Lightning Audio Dealer

- **Limit on Implied Warranties**

Any implied warranties including warranties of fitness for use and merchantability are limited in duration to the period of the express warranty set forth above. Some states do not allow limitations on the length of an implied warranty, so this limitation may not apply. No person is authorized to assume for Lightning Audio any other liability in connection with the sale of the product.

- **How to Obtain Service**

Please call 1-888-881-8186 for Lightning Audio Customer Service. You must obtain an RA# (Return Authorization number) to return any product to Lightning Audio. You are responsible for shipment of product to Lightning Audio. Always include Proof of Purchase. Mark RA# on outside of shipping carton

Ship to: **Electronics**
Lightning Audio
Warranty Repair Department
2055 E. 5th Street
Tempe, AZ 85281
RA#: _____

NOTES



MADE IN CHINA

Lightning Audio

955 N. Fiesta Blvd, Suite 4
Gilbert, Arizona 85233 U.S.A.

In U.S.A., (480) 966-8278

In Europe, Fax (49) 850-3934-014

In Japan, Fax (81) 559-79-1265

Free Manuals Download Website

<http://myh66.com>

<http://usermanuals.us>

<http://www.somanuals.com>

<http://www.4manuals.cc>

<http://www.manual-lib.com>

<http://www.404manual.com>

<http://www.luxmanual.com>

<http://aubethermostatmanual.com>

Golf course search by state

<http://golfingnear.com>

Email search by domain

<http://emailbydomain.com>

Auto manuals search

<http://auto.somanuals.com>

TV manuals search

<http://tv.somanuals.com>