

SERVICE MANUAL

(INTERNATIONAL)

IMPINGER CONVEYOR OVENS

MODEL 1421-000-E, 1454, 1455

WITH PUSH BUTTON CONTROLS



Lincoln Foodservice Products, LLC
1111 North Hadley Road
Fort Wayne, Indiana 46804
United States of America

Phone: (800) 374-3004

U.S. Fax: (888) 790-8193 • Int'l Fax: (260) 436-0735

Technical Service Hot Line
(800) 678-9511

www.lincolnfp.com



**SEQUENCE OF OPERATION
IMPINGER ADVANTAGE
SERIAL NUMBER N28654 AND ABOVE
(OVENS WITH PUSH BUTTON CONTROLS)**

MODEL 1421-000-E

230/400 VAC 50 HZ.

3 PHASE

POWER SUPPLY	Electrical power is to be supplied to the oven by a five conductor service. Brown conductor is hot. Black conductor is hot. Black conductor is hot. Blue conductor is neutral. Green conductor is ground.
CONTROL BOX AUTO COOL DOWN	When the temperature in the control box reaches 120°F ± 3°F (48.9°C ± 1.7°C), the cooling fan thermostat will switch power to the control box cooling fan. The thermostat will interrupt power to the cooling fan when the control box temperature falls to 100°F ± 3°F (37°C ± 1.7°C).
MAIN FAN CIRCUIT	Electrical power is permanently supplied through three 50 A fuses to the normally open contacts of the hi-limit contactor. Power is also supplied, through the 10 Amp motor and control fuse, through the normally closed control box hi-limit thermostat, to the normally open oven power switch. Power is also supplied to the control box cooling fan thermostat. Closing the oven power switch supplies line voltage to the main fan motor. Closing the oven power switch also supplies line voltage to the heat circuit and to the primary of the oven control transformer.
HEAT CIRCUIT	Closing the oven power switch supplies line voltage through the main fan air pressure switch, through the normally closed oven cavity hi-limit thermostat, to the oven control
TEMPERATURE CONTROL	Closing the oven power switch supplies line voltage, through the EMI filter, to the primary of the control transformer and through the air pressure switch and oven cavity hi-limit, to the oven control. Secondary voltage, 24VAC, is supplied to the oven control. The oven control is set to desired temperature. The thermocouple will provide varying millivolts to the oven control. The oven control supplies line voltage to the heat contactor at intermittent intervals to maintain desired temperature. The display on the oven control will indicate when the heat contactor is energized. NOTE: The display also indicates oven temperature.
CONVEYOR DRIVE	Closing the oven power switch supplies line voltage to the conveyor motor and to the primary of the control transformer. Secondary voltage, 24VAC, is supplied to the oven control. Setting the oven control to the desired time outputs voltage, through a reversing switch, to the conveyor motor. NOTE: The conveyor system uses a hall effect sensor and magnet to prove operation of the conveyor motor. If the motor is not running, "BELT JAM" is indicated on the display.

**SEQUENCE OF OPERATION
IMPINGER ADVANTAGE
SERIAL NUMBER N28654 AND ABOVE
(OVENS WITH PUSH BUTTON CONTROLS)**

MODEL 1454	220/380VAC	50 HZ.	3 PHASE
MODEL 1455	240/415VAC	50 HZ.	3 PHASE

POWER SUPPLY	Electrical power is to be supplied to the oven by a five conductor service. Brown conductor is hot. Black conductor is hot. Black conductor is hot. Blue conductor is neutral. Green conductor is ground.
CONTROL BOX AUTO COOL DOWN	When the temperature in the control box reaches 120°F ± 3°F (48.9°C ± 1.7°C), the cooling fan thermostat will switch power to the control box cooling fan. The thermostat will interrupt power to the cooling fan when the control box temperature falls to 100°F ± 3°F (37°C ± 1.7°C).
MAIN FAN CIRCUIT	Electrical power is permanently supplied through three 50 A fuses to the normally open contacts of the heat relay. Power is also supplied, through the 10 Amp motor and control fuse, through the normally closed control box hi-limit thermostat, to the normally open oven power switch. Power is also supplied to the control box cooling fan thermostat. Closing the oven power switch supplies line voltage to the main fan motor. Closing the oven power switch also supplies line voltage to the heat circuit and to the primary of the oven control transformer.
HEAT CIRCUIT	Closing the oven power switch supplies line voltage through the main fan air pressure switch, through the normally closed oven cavity hi-limit thermostat, to the oven control
TEMPERATURE CONTROL	Closing the oven power switch supplies line voltage to the primary of the control transformer and through the air pressure switch and oven cavity hi-limit, to the oven control. Secondary voltage, 24VAC, is supplied to the oven control. The oven control is set to desired temperature. The thermocouple will provide varying millivolts to the oven control. The oven control supplies line voltage to the heat contactor at intermittent intervals to maintain desired temperature. The display on the oven control will indicate when the heat contactor is energized. NOTE: The display also indicates oven temperature.
CONVEYOR DRIVE	Closing the oven power switch supplies line voltage to the conveyor motor and to the primary of the control transformer. Secondary voltage, 24VAC, is supplied to the oven control. Setting the oven control to the desired time outputs voltage, through a reversing switch, to the conveyor motor. NOTE: The conveyor system uses a hall effect sensor and magnet to prove operation of the conveyor motor. If the motor is not running, "BELT JAM" is indicated on the display.

**SCHEMATIC DIAGRAM
MODEL 1421-000-E,
SERIAL NUMBER N28654 AND ABOVE**

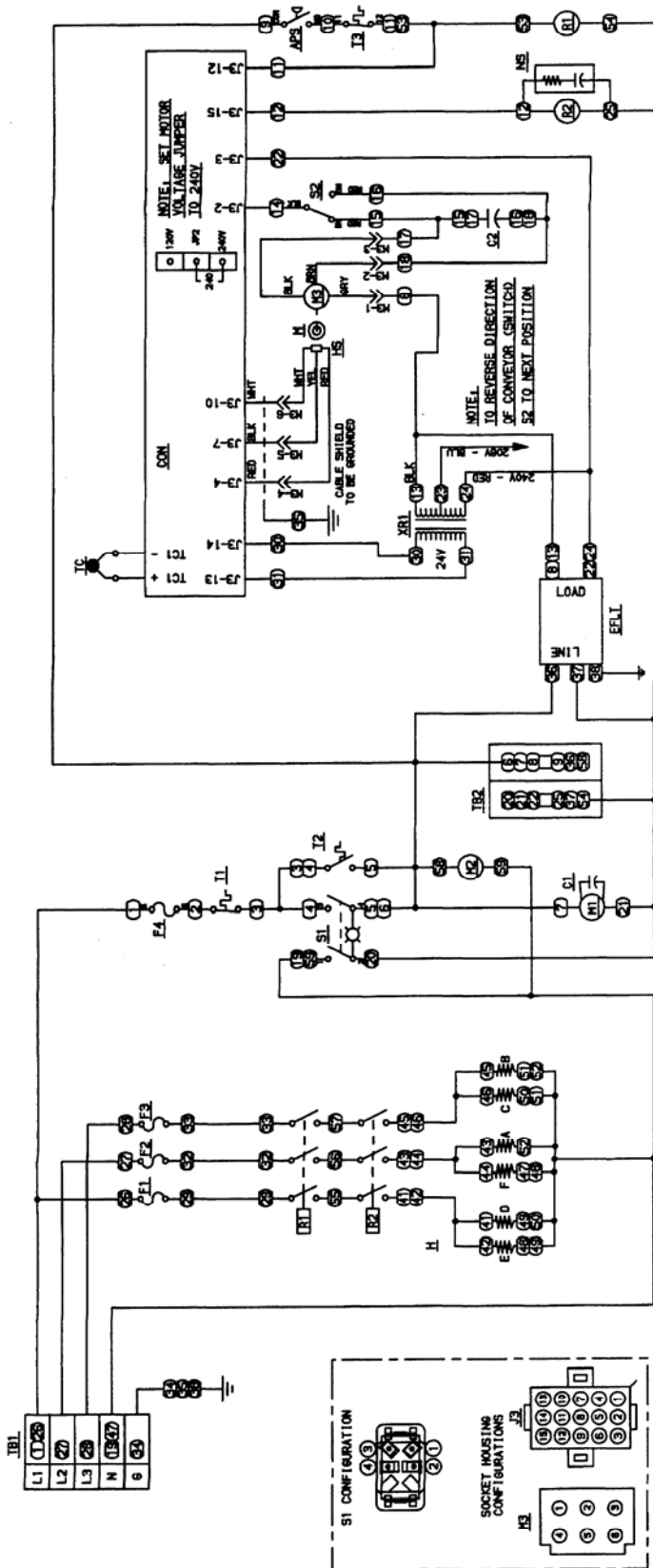

Lincoln
Foodservice Products, Inc.
FORT WAYNE, INDIANA
IMPINGER I ADVANTAGE

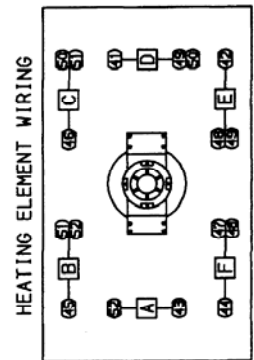

- HEATING ELEMENT WIRING
- N5 - NOISE SUPPRESSOR
 - R1 - CONTACTOR, HIGH LIMIT, 3P
 - R2 - CONTACTOR, HEATER, 3P
 - S1 - SWITCH, MAIN POWER
 - S2 - SWITCH, CONVEYOR REVERSING
 - T1 - THERMOSTAT, CONTROL BOX HIGH LIMIT
 - T2 - THERMOSTAT, COOLING FAN
 - T3 - THERMOSTAT, OVEN HIGH LIMIT
 - TB1 - TERMINAL BLOCK, SUPPLY
 - TB2 - TERMINAL BLOCK, DISTRIBUTION
 - TC - THERMOUPLE, TYPE K
 - XR1 - TRANSFORMER, CONTROL
 - (XX) - WIRE NUMBERS

- APS - AIR PRESSURE SWITCH
- C1 - CAPACITOR, MAIN FAN, 7.5 MFD
- C2 - CAPACITOR, CONVEYOR MOTOR
- CON - CONTROL, OVEN
- EFLT - FILTER, EMI
- F1-F3 - FUSE, HEATER, 50A
- F4 - FUSE, FAN MOTOR & CONTROLS, 10A
- H - HEATER, 4500 W
- HS - HALL EFFECT SENSOR
- M - MAGNET
- M1 - MOTOR, OVEN FAN
- M2 - MOTOR, COOLING FAN
- M3 - MOTOR, CONVEYOR

2806399A

**SCHEMATIC DIAGRAM
MODEL 1454, 1455
SERIAL NUMBER N28654 AND ABOVE**

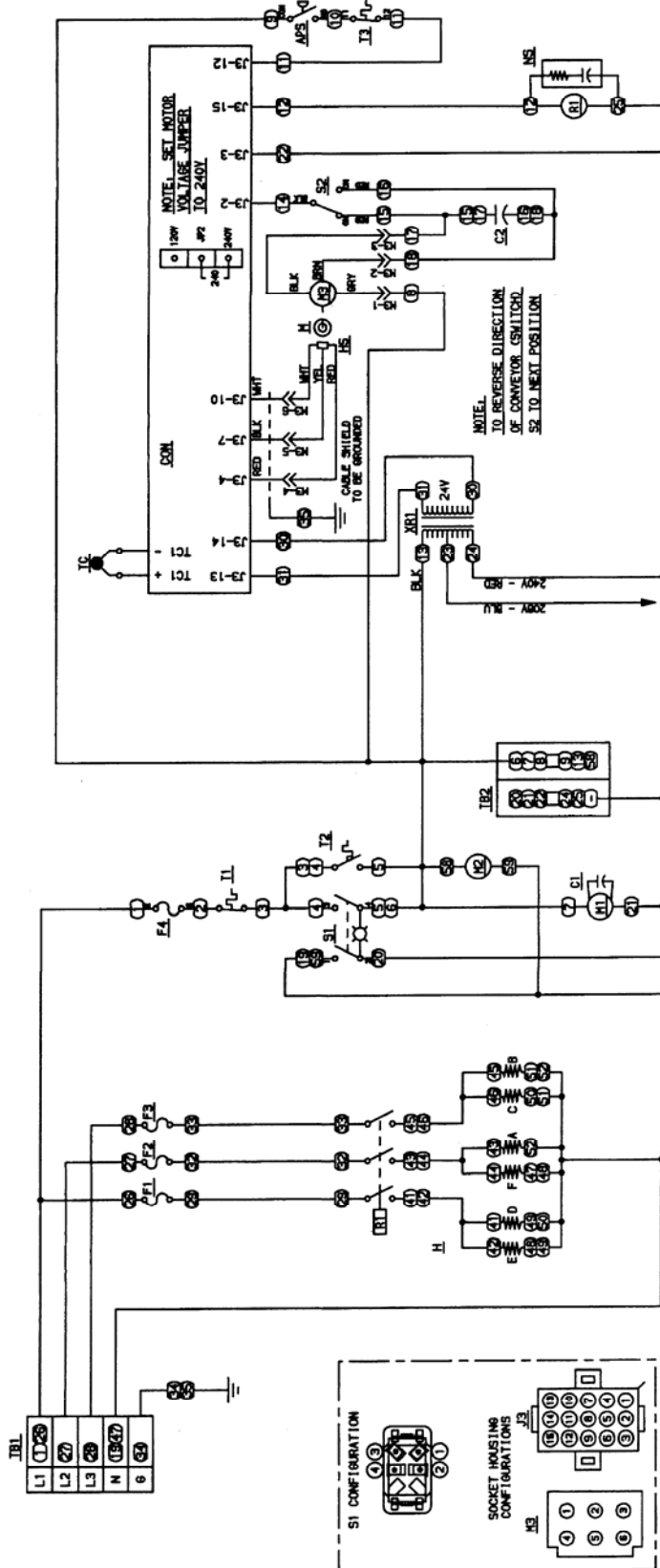

TROUBLESHOOTING GUIDE

- APS - AIR PRESSURE SWITCH
- C1 - CAPACITOR, MAIN FAN, 7.5 MFD
- C2 - CAPACITOR, CONVEYOR MOTOR
- CON - CONTROL, OVEN
- F1-F3 - FUSE, HEATER, 50A
- F4 - FUSE, FAN MOTOR & CONTROLS, 10A
- H - HEATER, 4500 W
- H5 - HALL EFFECT SENSOR
- M - MAGNET
- M1 - MOTOR, OVEN FAN
- M2 - MOTOR, COOLING FAN
- M3 - MOTOR, CONVEYOR

- NS - NOISE SUPPRESSOR
- R1 - CONTACTOR, HEATER, 3P
- S1 - SWITCH, MAIN POWER
- S2 - SWITCH, CONVEYOR REVERSING
- T1 - THERMOSTAT, CONTROL BOX HIGH LIMIT
- T2 - THERMOSTAT, COOLING FAN
- T3 - THERMOSTAT, OVEN HIGH LIMIT
- TB1 - TERMINAL BLOCK, SUPPLY
- TB2 - TERMINAL BLOCK, DISTRIBUTION
- TC - THERMOCOUPLE, TYPE K
- XX - WIRE NUMBERS

Lincoln
Foodservice Products, Inc.
FORT WAYNE, INDIANA
IMPINGER I ADVANTAGE

28063988

**IMPINGER ADVANTAGE ELECTRIC OVENS
SERIAL NUMBER N28654 AND ABOVE
(OVENS WITH PUSH BUTTON CONTROLS)**

SYMPTOM	POSSIBLE CAUSE	EVALUATION
Oven fan will not run	Incoming power supply	Check circuit breaker, reset if required. Check power plug to be sure it is firmly in receptacle. Measure incoming power, call power co. if required.
	Fuse, 10 Amp	Check, replace if necessary.
	Fuse holder	Check, replace if necessary.
	Thermostat, control box hi-limit	Terminals are normally closed, open at 130°F (55°C). If open, reset and test for proper operation. If thermostat will not hold, and control box temperature is not exceeding 130°F (55°C), replace thermostat.
	Switch, oven power	Check for line voltage supplied to switch. If no voltage is present, trace wiring back to fuse holder. Check continuity between switch terminals. Replace switch as needed.
No control box cooling	Motor, main fan	Check for line voltage supplied to motor. If no voltage is present, trace wiring back to oven power switch. Check motor for opens, shorts or grounds. WITH POWER OFF: Turn fan blade to check for locked rotor.
	Incoming power supply	Check circuit breaker, reset if required. Check power plug to be sure it is firmly in receptacle. Measure incoming power, call power co. if required.
	Fuse, 10 Amp	Check, replace if necessary.
	Fuse holder	Check, replace if necessary.
	Switch, oven power	Check for line voltage supplied to switch. If no voltage is present, trace wiring back to fuse holder. Check continuity between switch terminals. Replace switch as needed.
No automatic control box cooling	Cooling fan	Check for supply voltage to the cooling fan. If no voltage is present, trace wiring back to the fuse holder. If voltage is present and motor does not run, check motor for opens shorts or grounds. WITH POWER OFF: Check for locked rotor.
	Incoming power supply	Check circuit breaker, reset if required. Check power plug to be sure it is firmly in receptacle. Measure incoming power, call power co. if required.
	Cooling fan thermostat	Check cooling fan thermostat (thermostat closes at 120°F and opens at 100°F). With cooling fan thermostat pre-heated, check for continuity
Control box cooling fan continues to run	Cooling fan thermostat	See "Cooling fan thermostat" (NOTE: Thermostat will remain closed if control box temperature remains above 120°F.
Oven will not heat	Main fan	If not operating, refer to "Oven fan will not run"
	Air pressure switch	Check air switch terminals for supply voltage to terminals NO and COM. If voltage is present on one side only, check for air tube blockage or misalignment. If these are okay, adjust air pressure switch or replace switch as needed.
	Oven cavity hi-limit thermostat	Terminals are normally closed, opens at 660°F (350°C). If open, reset and test oven for proper operation. If thermostat will not hold for maximum temperature, and oven is not exceeding control setting, check for proper location of the capillary bulb in its spring holder. If above checks are okay, replace hi-limit thermostat.
	Control transformer	Check for supply voltage to primary of control transformer. If no voltage is present, trace wiring back to oven power switch. If voltage is present, check for

		24VAC at transformer secondary. If there is primary voltage, but no secondary voltage, replace control transformer.
	Oven control	Check for 24VAC supply to oven control. If no voltage is present, trace wiring back to control transformer. Check for supply voltage to oven control. If no voltage is present, trace wiring back to hi-limit thermostat. If voltage is present, check for a read-out on the display. If there is no read-out on the display, replace oven control. If there is a read-out on the display, set the oven control to maximum temperature (see installation operations manual for temperature adjustment). With the oven control at maximum temperature, check for supply voltage to the heat contactor. If there is voltage at the heat contactor, proceed to "Heat contactor ". If there is no voltage at the heat contactor, trace wiring back to the oven control. If there is no voltage output at the oven control, check the read-out on the oven control. If the oven control reads "PROBE FAIL" this indicates that the thermocouple has failed or become disconnected from the oven control
	Contactors, hi-limit (Model 1421-000-E only)	Check for supply voltage to contactor coil. If no voltage is present, trace wiring back to oven cavity hi-limit thermostat. If supply voltage is present at the coil, check to see that contacts are closed. If there is voltage to the coil and the contacts are not closed, replace contactor.
	Thermocouple	Check to see that the thermocouple is securely connected to the oven control. If the thermocouple is connected to the oven control, and the display indicates "PROBE FAIL", disconnect the thermocouple from the oven control and measure the resistance of the thermocouple. The thermocouple should read approx. 11Ω. If these readings are not achieved, replace the thermocouple. If these readings are correct, proceed.
	Oven control	If the thermocouple checks good, but the oven control display indicates that there is a thermocouple failure, replace the oven control. If the oven control indicates a temperature reading, but the oven will not heat, proceed.
	Thermocouple	WITH POWER ON AND THERMOCOUPLE ATTACHED TO THE OVEN CONTROL: Measure the DC millivolt output of the thermocouple. Refer to the thermocouple chart (located in the "Removal" section of the manual) for proper millivolt readings. If these readings are not achieved, replace thermocouple.
	Oven control	If the thermocouple checks good, but there is no supply voltage output to the temperature regulation valve, replace the oven control. If there is supply voltage output to the heat contactor, proceed.
	Heat contactor	Check for supply voltage to the heat contactor. If voltage is present, listen for contacts to open and close. Also check for opens or shorts in the operating coil. Replace heat contactor as needed.
Intermittent heating	Thermal/overload of main fan motor	The main fan motor is equipped with internal thermal protection and will cease to operate if overheating occurs. As the motor overheats and cool, this will cause the heating system to cycle on and off intermittently. Improper ventilation or lack of preventive maintenance may cause this problem. Also most of the problems listed under "Oven will not heat" can cause intermittent failure.
Conveyor will not run	Incoming power supply	Check circuit breaker, reset if required. Check power

		plug to be sure it is firmly in receptacle. Measure incoming power, call power co. if required.
	Fuse, 10 Amp	Check, replace if necessary.
	Fuse holder	Check, replace if necessary.
	Switch, oven power	Check for line voltage supplied to switch. If no voltage is present, trace wiring back to fuse holder. Check continuity between switch terminals. Replace switch as needed.
	Control transformer	Check for supply voltage to primary of control transformer. If no voltage is present, trace wiring back to oven power switch. If voltage is present, check for 24VAC at transformer secondary. If there is primary voltage, but no secondary voltage, replace control transformer.
	Conveyor motor	Check for supply voltage to the conveyor motor at terminal #8 to neutral. If no voltage is present, trace wiring back to oven power switch. If voltage is present, but the motor will not run, check the motor windings for opens or shorts. If any of the above checks fail, replace conveyor motor.
	Capacitor, conveyor motor	Check for shorts or grounds. Replace capacitor as needed. WARNING: Capacitor has a stored charge, discharge before testing.
	Switch, conveyor reversing	Check continuity between switch terminals. Replace switch as needed.
	Oven control	If there is voltage supplied to the motor, and the motor capacitor and reversing switch check good, replace the oven control.
Conveyor motor runs, but there is no speed display	NOTE: Display will indicate "BELT JAM"	
	Oven control	Check for output voltage from oven control to hall effect sensor (sensor is located in the conveyor motor). Measure voltage at the motor connector, red wire and yellow wire. Voltage should be approx. 10VDC. If no voltage is present, trace wiring back to oven control. If there is no voltage output at the oven control, replace oven control.
	Conveyor motor	If there is voltage supplied to the hall effect sensor, check for a frequency output from the hall effect sensor. Measure frequency across the yellow and white wires in the motor connector. Frequency reading should be approx. 25-100 Hz. If these readings are not achieved, replace conveyor motor. If the readings are achieved, proceed.
	Oven control	If the hall effect sensor readings are correct, but there is no speed indicated on the display, replace the oven control.

REMOVAL, INSTALLATION & ADJUSTMENTS

IMPINGER ADVANTAGE SERIES

CAUTION!

BEFORE REMOVING OR INSTALLING ANY COMPONENT IN THE IMPINGER OVEN BE SURE TO DISCONNECT ELECTRICAL POWER AND GAS SUPPLY

MOTOR, MAIN FAN - REPLACEMENT

1. Shut off power at main breaker.
2. Remove louvered motor cover from back of oven.
3. Remove wireway by taking out the (5) five hex screws.
4. Disconnect wiring from motor.
5. Remove the twelve (12) hex head bolts from the oven back and slide back straight out of the oven.
6. Remove two (2) bolts from fan hub and remove fan from motor shaft.
NOTE: Measure distance from fan blade to rear wall assembly before removal to aid in reassembly.
7. Remove the eight (8) hex head bolts from the motor mount and slide the motor assembly out of the oven back.
8. Remove motor by taking off motor clamp and removing the four (4) mounting nuts and washers.
9. Reassemble in reverse order. When motor mount assembly is set on the oven back, align motor shaft in the center of the hole. Set fan assembly on the motor shaft.
NOTE: A. Torque specs on bolts (150 in/lb. torque)
B. It is recommended that an anti-seize compound be brushed on to the bolts around the back and motor mount bracket before assembly.

FAN, MAIN - REPLACEMENT

Shut off power at main breaker.

Remove back assembly. (See MOTOR, MAIN FAN))

Reinstall and locate fan so that the bottom of the fan spider is 1 1/2" from the top of the oven back cone. (See Drawing)

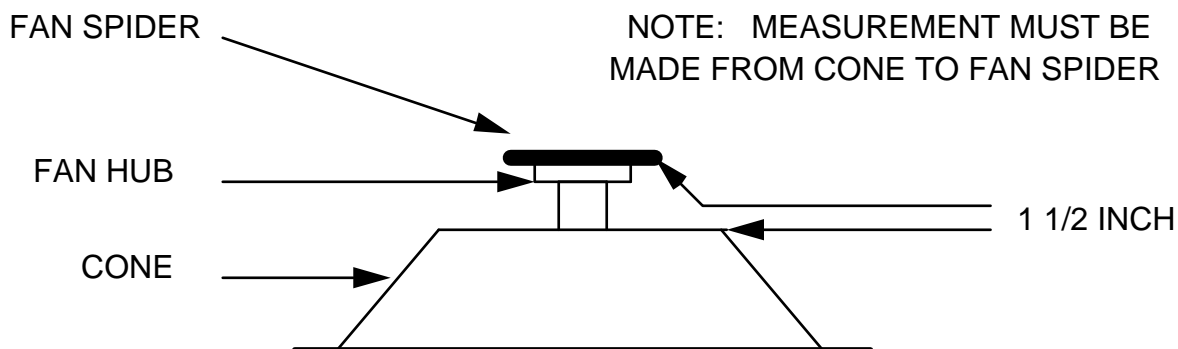

CAPACITOR, MOTOR - REPLACEMENT

1. Shut off power at main breaker.
2. Remove motor cover from back of oven.
3. Discharge capacitor.
4. Remove and replace.

COOLING FAN, CONTROL BOX - REPLACEMENT

1. Shut off power at main breaker.
2. Remove control panel top and front cover.
3. Remove four (4) screws from the fan frame.
4. Disconnect cord and plug and remove fan.
5. Reassemble in reverse order.

THERMOSTAT, COOLING FAN - REPLACEMENT

1. Shut off power at main breaker.
2. Remove control panel top and front cover.
3. Remove lead wires and mark for reassembly.
4. Remove two (2) screws and remove thermostat.
5. Reassemble in reverse order.

THERMOSTAT, OVEN CAVITY HI-LIMIT – REPLACEMENT

1. Shut off power at main breaker.
2. Remove control box cover and front panel. Remove conveyor assembly and fingers from oven to aid in removal of thermostat from oven.
3. Disconnect wires from thermostat and mark for reassembly.
4. Remove thermostat from oven.
5. Reassemble in reverse order and check system operation.

AIR PRESSURE SWITCH – REPLACEMENT

1. Shut off power at main breaker.
2. Remove control panel top and front cover.
3. Disconnect wires from air pressure switch and mark for reassembly.
4. Remove air switch tube from air pressure switch.
5. NOTE: There are two types of air pressure switches used. Remove air pressure switch from its mount.
6. Reassemble in reverse order and check system operation.
7. To adjust air pressure switch, remove cover from switch to expose adjusting screw. To increase sensitivity, turn screw counter-clockwise. To decrease sensitivity, turn screw clockwise.

THERMOCOUPLE (TYPE K) - REPLACEMENT

1. Shut off power at main breaker.
2. Remove control panel top and front cover.
3. Slide thermocouple out of oven chamber.
NOTE: Remove conveyor and bottom fingers to aid in removal and installation of thermocouple.
4. Remove two (2) wires from temperature control. Make note of wire numbers or color and location for reinstallation.
5. Reassemble in reverse order making sure the metal end on the thermocouple is in the wire form in the oven chamber.

THERMOCOUPLE MEASUREMENT

TEMPERATURE	D.C. MILLVOLTS (APPROX.)
200°	2.8
250°	4.0
300°	5.1
350°	6.0
400°	7.1
450°	8.2
500°	9.3
550°	10.4
600°	11.5

CONTROL TRANSFORMER - REPLACEMENT

1. Shut power off at main breaker.
2. Remove control panel top and front cover.
3. Remove two (2) wires on primary side, note color and location.
4. Remove two (2) wires on secondary side, note color and location.
5. Remove two (2) screws from transformer base and replace assembly.
6. Reinstall in reverse order and check system operation.

CONVEYOR DRIVE MOTOR - REPLACEMENT

1. Shut power off at main breaker.
2. Remove control panel top and front cover.
3. Loosen set screw on conveyor drive sprocket and slide sprocket off shaft.
4. Disconnect motor plug.
5. Remove four (4) screws from motor frame, on control box side, and remove motor assembly.
6. Reassemble in reverse order making sure to align chain sprockets and adjust motor for proper chain tension (1/2" SAG).

CAPACITOR, CONVEYOR MOTOR – REPLACEMENT

1. Shut off power at main breaker.
2. Remove control box cover and front panel.
3. Discharge capacitor before removing wires. Mark wires for reassembly.
4. Remove mounting screw and remove capacitor.
5. Reassemble in reverse order and check system operation.

REVERSING SWITCH – REPLACEMENT

1. Shut off power at main breaker.
2. Remove control box cover and front panel.
3. Disconnect wires from reversing switch and mark for reassembly.
4. Remove mounting nut and remove reversing switch.
5. Reassemble in reverse order and check system operation.

REVERSING CONVEYOR DIRECTION

All ovens leaving our plant are wired to operate conveyors from left to right. To reverse conveyor direction, use the following procedure.

1. Shut off power at oven switch.
2. Set conveyor reversing switch in the other position.
3. Turn oven "on" and check for proper operation.

ON-OFF SWITCH - REPLACEMENT

1. Shut off power at main breaker.
 2. Remove control box cover.
 3. Remove access cover.
 4. Depress spring clips on side of switch and push out.
 5. Remove wires from back of switch, note wire number and location.
 6. Reassemble in reverse order and check system operation.
- NOTE: Make sure switch housing is fully seated in control box housing.

OVEN CONTROL – REPLACEMENT

- A. Shut off power at main breaker.
- B. Remove control box cover and front panel.
- C. Remove all wiring connections and mark for reassembly.
- D. Remove oven control by pulling control from the mounting pins. Remove control from oven.
- E. Before installing new oven control, set voltage jumper (located at the bottom center of the oven control) to the proper voltage (120V/240V) position. Install the four pushbutton extensions

(included with the oven control) by pushing the extensions onto the four set buttons on control.

- F. Reassemble in reverse order and check system operation.
- G. Set the oven control for the proper operating mode. The 1400 series ovens use a single temperature control system. The oven control must be set to the proper operating mode. Set the control as follows: With the oven power switch "off", depress the "time" and "up" buttons and turn the oven "on". Control will indicate "Imp I or Imp II" Release the buttons. Press the "up" or "down" button until "Imp I" and "temp to store" appears on the display. Press the "temp" button. The control is now set for Impinger I conveyor and single burner operation.

FUSE HOLDER – REPLACEMENT

1. Shut off power at main breaker.
2. Remove control box cover.
3. Remove all wiring from fuse holder and mark for reassembly.
4. Remove mounting nut for fuse holder and remove fuse holder.
5. Reassemble in reverse order and check system operation.

BEARING, CONVEYOR – REPLACEMENT

1. Remove conveyor from oven and place on flat work surface.
2. Remove connecting links from conveyor belt. See Installation and operations manual.
3. Remove conveyor belt from conveyor. Remove drive sprocket from drive shaft if required.
4. Move shaft toward end of conveyor, and shaft with bearings will now slip out of holding bracket.
5. Replace bearing and reassemble in reverse order.

HEAT CONTACTOR – REPLACEMENT

1. Shut off power at main breaker.
2. Remove control box cover and front panel.
3. Remove all wiring from contactor and mark for reassembly.
4. Remove mounting screws and remove contactor.
5. Reassemble in reverse order and check system operation. NOTE: be sure that contactor is not mounted upside down, as this will cause a constant "on" condition.

HI-LIMIT CONTACTOR – REPLACEMENT

See "HEAT CONTACTOR – REPLACEMENT"

EMI FILTER – REPLACEMENT

1. Shut off power at main breaker.
2. Remove control box cover and front panel.
3. Remove all wiring from filter and mark for reassembly.
4. Remove mounting screws and remove filter.
5. Reassemble in reverse order and check system operation.

HEATING ELEMENT – REPLACEMENT

1. Shut off power at main breaker.
2. Remove back cover.
3. Disconnect wiring from heating element and mark wires for reassembly.
4. Disconnect motor wiring and mark for reassembly.
5. Remove oven back assembly from oven.
6. Remove fan shroud.
7. Remove heating element from oven back.
8. Reassemble in reverse order and check system operation. NOTE: Be sure heating element connections are tight.

THERMOSTAT, CONTROL BOX HI-LIMIT – REPLACEMENT

1. Shut off power at main breaker.
2. Remove control box cover and front panel.
3. Remove wiring from thermostat and mark for reassembly.
4. Remove mounting screws and remove thermostat.
5. Reassemble in reverse order and check system operation. NOTE: Be sure to press reset button on new thermostat to set for operation.

GENERAL VIEW
ADVANTAGE SERIES

LETTER	PART NUMBER	DESCRIPTION
A	369003	Door hinge
B	369110	Access window assembly
C	369337	Retainer (old style)
	369929	Retainer (new style)
D	369828	Handle spacer
E	369209	Latch & strike
F	369310	Screw, 6-32 x 3/16"
G	369308	Bottom, access window
H	369334	Access door glass
J	369309	Top, access window
K	350638	Handle
L	369311	Handle spacer (2 req.)
M	369336	Door latch
N	369906	Screw, 8-32 x 5/8"
O	370110	Door assembly (solid)
P	369157	Door assembly (with window)
Q	1534	Finger support assembly
R	369057	Support bracket pin
S	369643	Strike assembly
T	1009	Oven top
U	369062	Top, control box
V	369140	Compression spring
W	369903	Washer, flat
X	369141	Conveyor hold down bracket
Y	369139	Shoulder screw
Z	369058	Baffle, inlet and outlet
*	369211	Thumb screw (not shown)
AA	369203	Stud, wing head
BB	369749	Chain cover kit (includes AA, CC)
CC	369204	Split ring retainer
DD	369373	Receptacle, snap -in
EE	369748	Bracket, chain cover
FF	369328	Leg, stand
GG	369052	Adjustable leg
HH	369030	Caster, 6"
JJ	369904	Insulation holder assembly
KK	369053	Finger housing
LL		Columnating plates – see installation operations manual
MM	369055	Finger cover
NN	369218	Crumb pan, internal
OO	369926	Window frame, bottom
PP	369925	Glass, access window
QQ	369927	Window frame, top

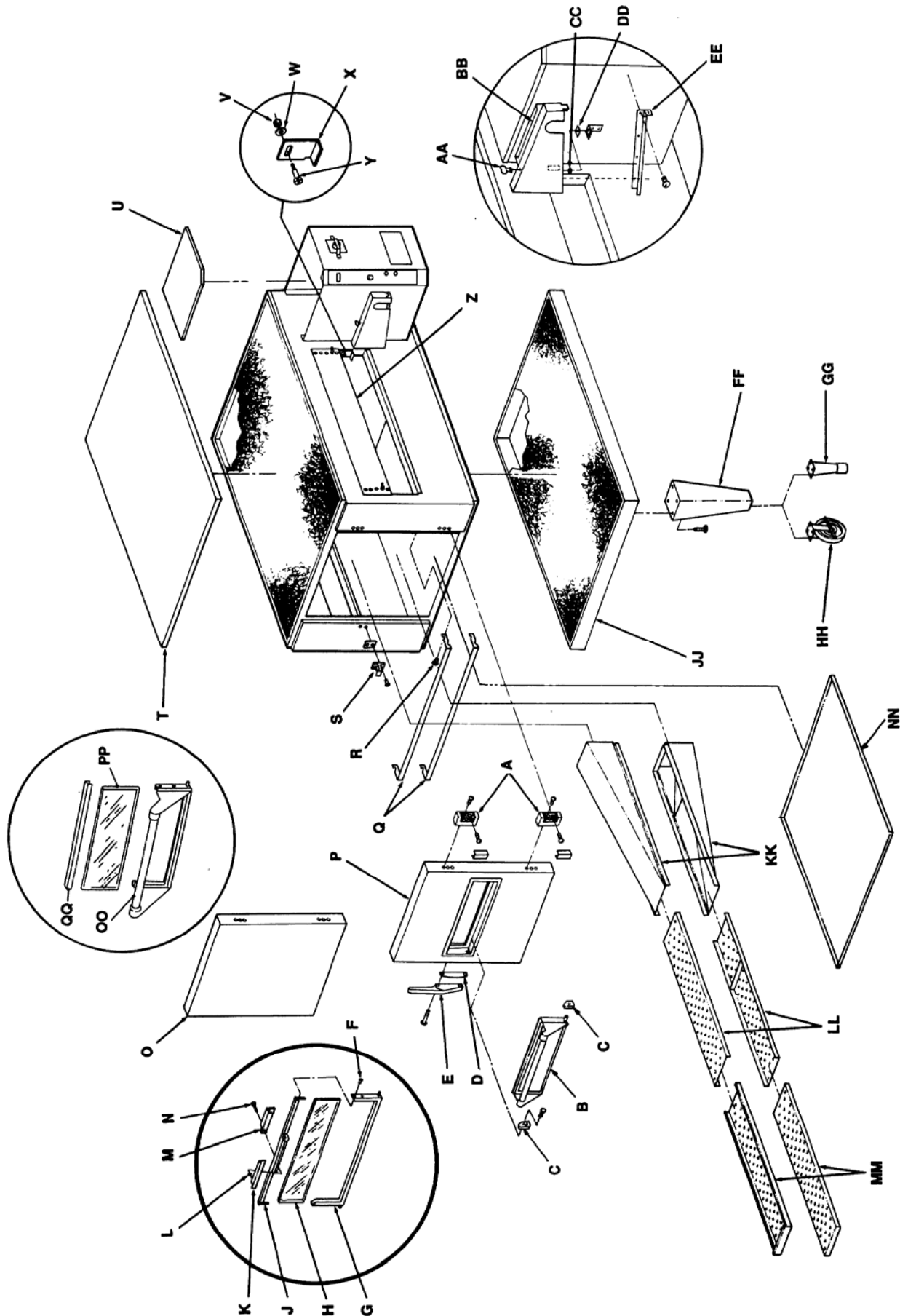

CONTROL BOX
1421-000-E, 1454,1455

LETTER	PART #	DESCRIPTION
A	369066	Sprocket, 10 tooth
B	370373	Conveyor motor
C	369507	Thermostat, cooling fan
D	369025	Air pressure switch
E	369119	Terminal block
F	369134	Fuse, 50A
G	370163	Terminal block, 5 Pole
H	370387	Filter, EMI
I	370485	Contactora, mercury
J	369838	Thermostat, control box hi-limit
K	357107	Fuse holder
L	369014	Fuse, 10A
M	369378	Cooling fan
N	369331	Finger guard
O	370359	Reversing switch
P	369368	Thermostat, oven cavity hi-limit
Q	370388	Cover, access
R	370360	Capacitor, Conveyor motor
S	4000054	Ground lug
T	369125	Terminal block, 2-pole
U	369427	Transformer, control
V	370362	Thermocouple, type "K"
W	370363	Front cover assembly
X	370354	Facia, label
Y	369432	Switch, on/off
Z	370355	Oven control
AA	7006831	Top, control panel

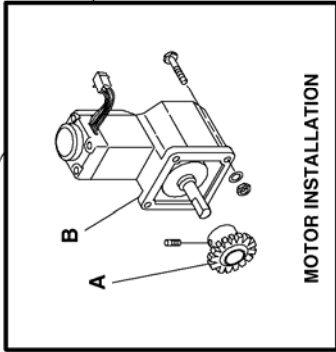
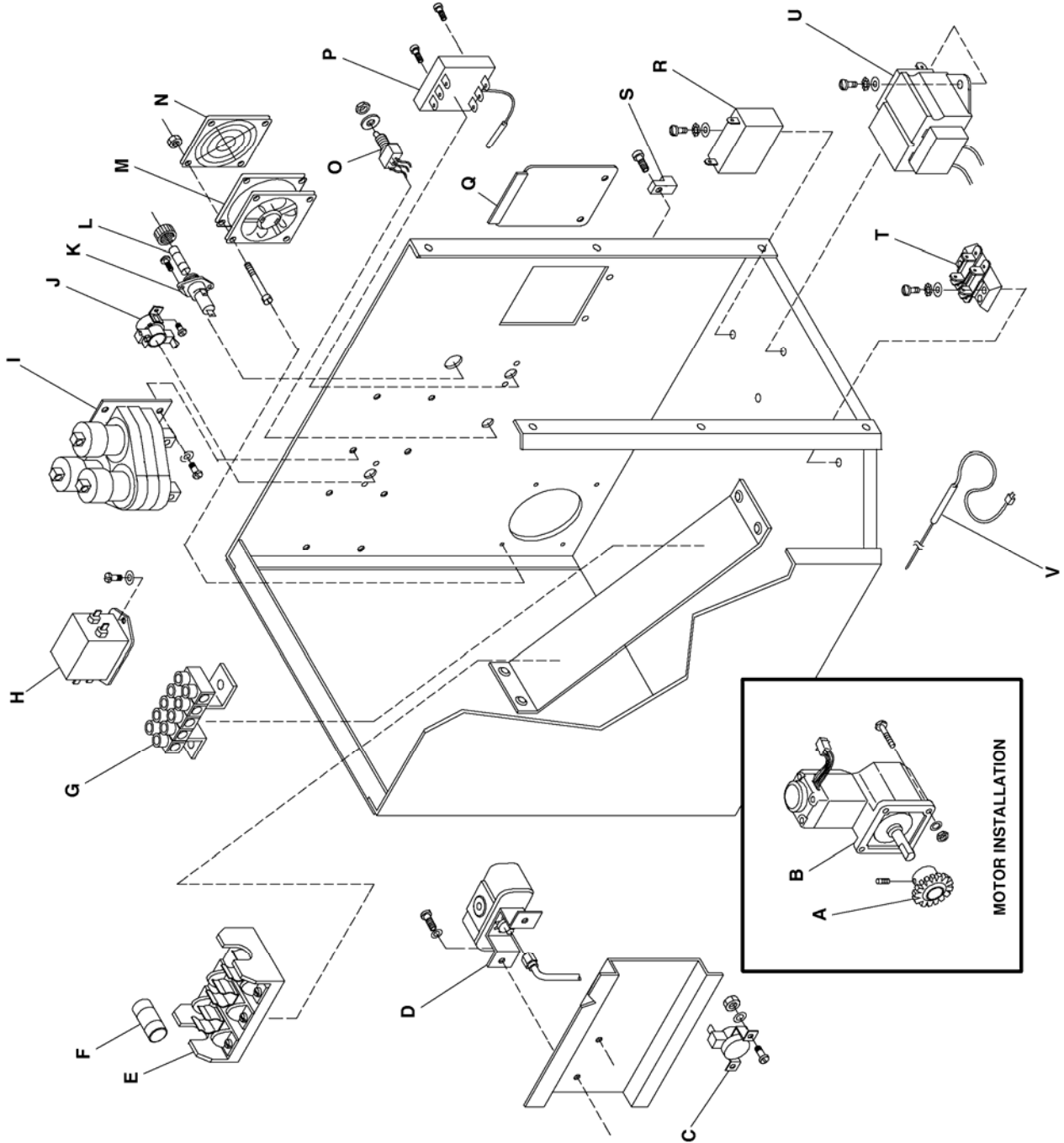
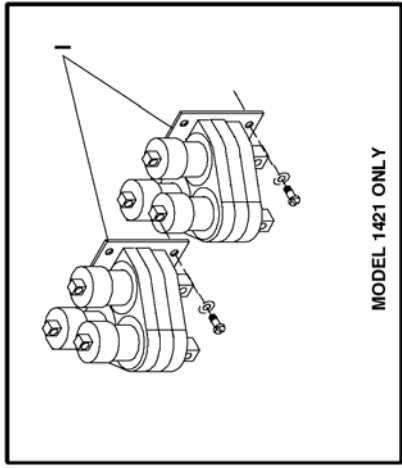
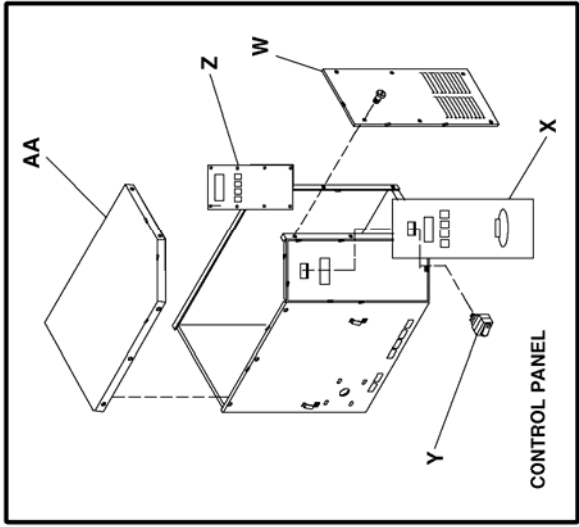

OVEN BACK
ADVANTAGE SERIES
GAS AND ELECTRIC

LETTER	PART NUMBER	DESCRIPTION
A	369808	Cover, motor (gas ovens)
	370140	Cover, motor (electric ovens)
B	369214	Motor, main fan (50 Hz.)
C	369033	Motor clamp
D	369215	Motor support assembly
E	369192	Capacitor, 7.5 MFD
F	369306	Oven back assembly, gas oven
G	369646	Stand-off
H	369647	Inlet panel
J	369213	Main fan
K	369547	Bracket, thermostat
M	369287	Heating element, 208V
	369315	Heating element, 220V
	369122	Heating element, 240V

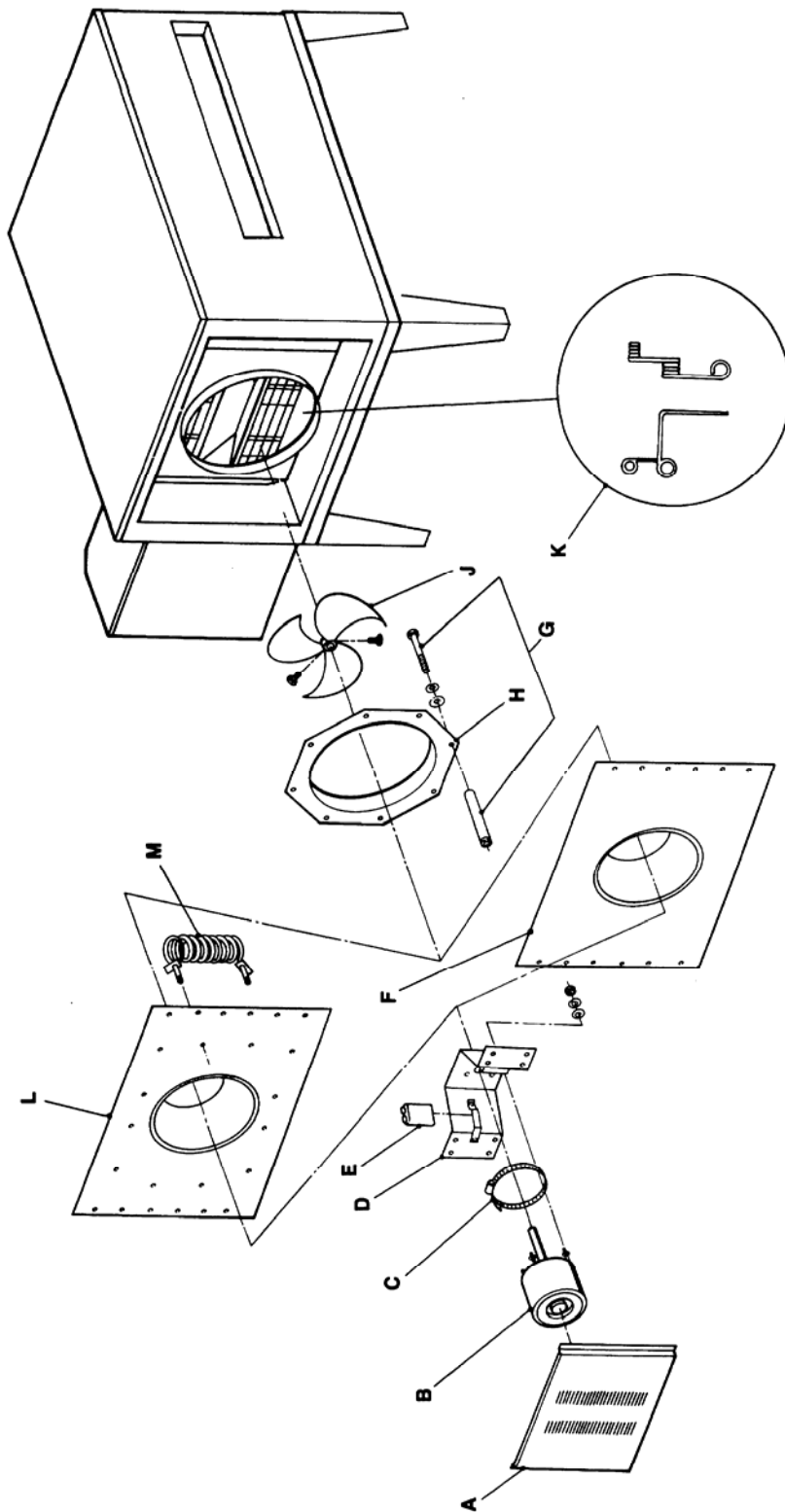

CONVEYOR 1450 SERIES

LETTER	PART NUMBER	DESCRIPTION
	369830	Complete conveyor assembly
A	369816	Conveyor belt, 30" Wide
	370092	Conveyor belt, 1 ft. section, 30" Wide
	369163	Conveyor Belt, 32" Wide (units mfg after 10/2003)
	369362	Conveyor Belt, 1 ft. section, 32" Wide (units mfg after 10/2003)
B	369825	Retaining ring
C	369813	Conveyor bearing block
D	369314	Roll, conveyor, notched
E	369812	Conveyor idler shaft
F	369160	Conveyor pan stop
G	369814	Connecting link (30 inch wide belt)
	369005	Connecting link (32 inch wide belt)
H	369811	Conveyor drive shaft
J	369161	Roller chain sprocket
K	369806	Crumb pan
L	370050	Conveyor frame
M	369162	Drive chain

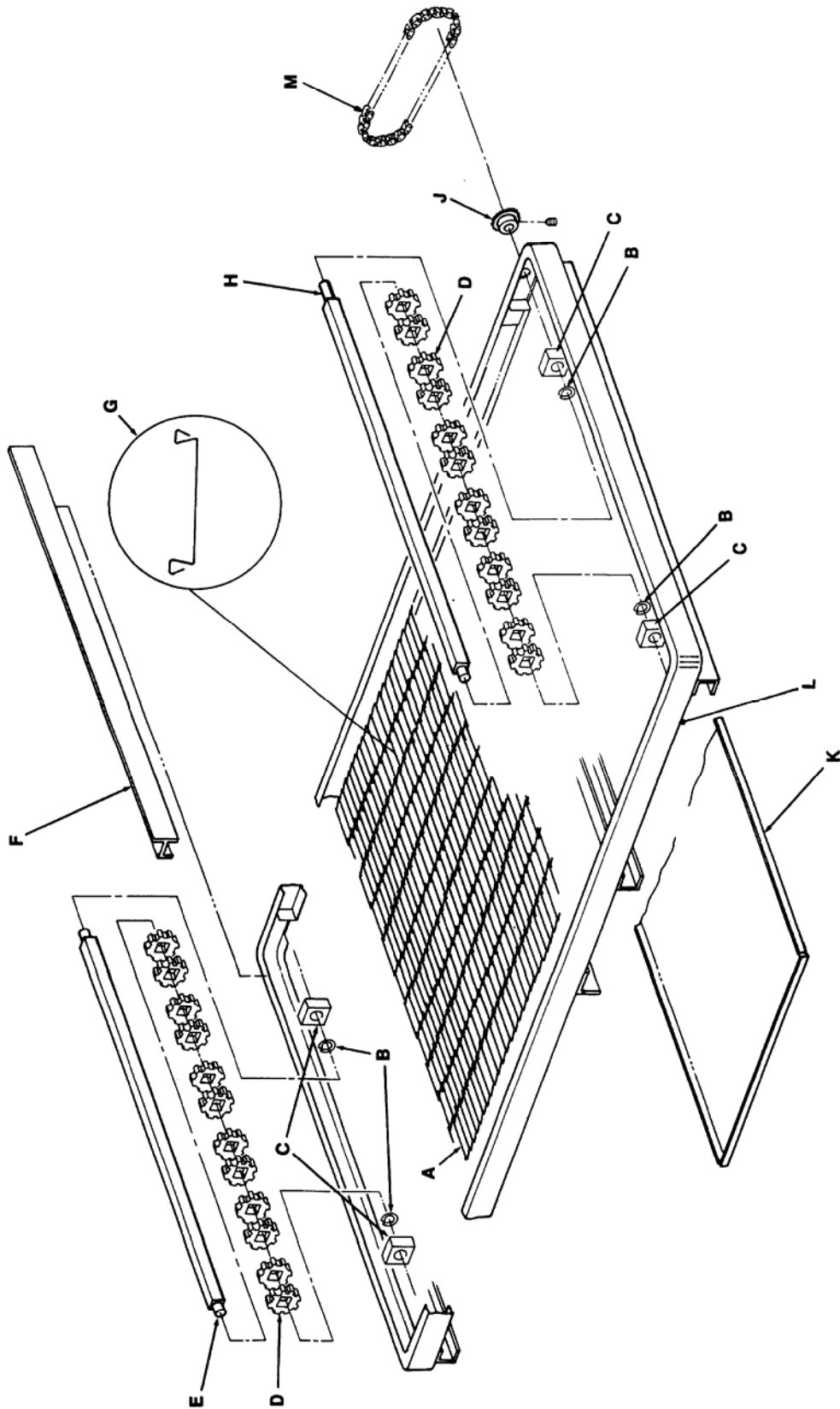

This page intentionally left blank.

This page intentionally left blank.



Lincoln Foodservice Products, LLC
1111 North Hadley Road
Fort Wayne, Indiana 46804
United States of America

Telephone: (260) 459-8200
U.S. Facsimile: (888) 790-8193
Int'l Facsimile: (260) 436-0735

Technical Service Hotline: (800) 678-9511

www.lincolnfp.com



Free Manuals Download Website

<http://myh66.com>

<http://usermanuals.us>

<http://www.somanuals.com>

<http://www.4manuals.cc>

<http://www.manual-lib.com>

<http://www.404manual.com>

<http://www.luxmanual.com>

<http://aubethermostatmanual.com>

Golf course search by state

<http://golfingnear.com>

Email search by domain

<http://emailbydomain.com>

Auto manuals search

<http://auto.somanuals.com>

TV manuals search

<http://tv.somanuals.com>