

SERVICE MANUAL

(INTERNATIONAL)

IMPINGER CONVEYOR OVENS

MODEL 1621-000-EA, 1628-000-A, 1629-000-A
WITH PUSH BUTTON CONTROLS



Lincoln Foodservice Products, LLC
1111 North Hadley Road
Fort Wayne, Indiana 46804
United States of America

Phone: (800) 374-3004
U.S. Fax: (888) 790-8193 • Int'l Fax: (260) 436-0735

Technical Service Hot Line
(800) 678-9511

www.lincolnfp.com



**SEQUENCE OF OPERATIONS
IMPINGER ELECTRIC LOW PROFILE ADVANTAGE
(WITH PUSH BUTTON CONTROL)**

MODEL 1621-000-EA 230/400 VAC 50HZ
MODEL 1628-000-A 220/380 VAC 50HZ
MODEL 1629-000-A 224/415 VAC 50HZ

POWER SUPPLY	Electrical power to be supplied to the oven by a five conductor service. Brown conductor is hot. Black conductor is hot. Black conductor is hot. Blue conductor is neutral. Green conductor is ground.
CONTROL BOX AUTO COOL DOWN	When the temperature in either one of the control boxes reaches 120°F ±3° (49°C ± 1.7°), the cooling fan thermostats will switch power to the cooling fans. The thermostats will interrupt power to the cooling fans when the temperature falls to 100°F ± 3° (37°C ± 1.7°)
MAIN FAN CIRCUIT	Line voltage is permanently supplied (through a power filter) to a normally open contact of the oven power switch. Line voltage is permanently supplied to the two normally open cooling fan thermostats. Closing the oven power switch supplies line voltage, through both normally closed control box hi-limit thermostats, to the oven power relay. Its contacts now close supplying line voltage to the two main fan motors. Closing the oven power switch also supplies line voltage to the control box cooling fans, the oven control, the control transformer, and the conveyor motor.
TEMPERATURE CONTROL	Closing the oven power switch supplies line voltage, through the 10 amp. fuse, through the oven power relay, to the primary of the control transformer. 24VAC is supplied to the oven control. The oven control is set to desired temperature. The thermocouple will provide varying millivolts to the oven control. The oven control supplies line voltage to the contactor at intermittent intervals to maintain desired temperature. The display on the oven control will indicate when the contactor is energized. NOTE: The display also indicates oven temperature.
CONVEYOR DRIVE	Closing the oven power switch supplies line voltage, through the 10 Amp fuse, through the oven power relay to the conveyor motor and to the primary of the control transformer. Secondary voltage, 24VAC, is supplied to the oven control. Setting the oven control to the desired time, outputs voltage, through a reversing switch, to the conveyor motor NOTE: The conveyor system uses a magnet and hall effect sensor to prove operation of the conveyor motor. If the conveyor motor is not running, "BELT JAM" is indicated on the display.
AUTOMATIC COOL DOWN	When the oven is started, the time delay relay timing circuit is enabled, permitting the oven fans to operate for approximately 20 minutes after the oven is shut off, to cool the oven. The time delay relay will keep the coil of the motor relay closed, maintaining operation of main fan and cooling motors.

TROUBLESHOOTING GUIDE

MODEL 1621-000 EA 230/400 VAC 50 HZ 3 PHASE
 MODEL 1628-000 A 220/380 VAC 50 HZ 3 PHASE
 MODEL 1629-000 A 240/415 VAC 50 HZ 3 PHASE

NOTE: When checking components on left side of unit, be sure to check for proper connections in power connector, (marked P. C. on schematic diagram) located inside motor cover.

SYMPTOM	POSSIBLE CAUSE	EVALUATION
Oven fan will not run	Incoming power supply	Check breakers/ reset if required call Power company if needed.
	Fuse, 10 A., main fan	Check, replace if necessary.
	Fuse holder	Check, replace if necessary.
	Filter, Power	Check for supply voltage to filter. If there is no voltage, trace wiring back to fuse holder. If there is power in to the filter, but no power out, replace the filter.
	Oven fan switch	Check continuity between switch terminals.
	20 minute time delay relay	Check for supply voltage to terminal #1 and #3, if there is no voltage, trace wiring back to the power filter. If voltage is present, check for supply voltage at terminals #3 to #6, if no voltage is present, trace wiring back to on/off switch. If there is voltage at #3 and #6, check for voltage at terminals #1 and #2, of there is no voltage at Terminals #1 and #2, replace the 20 minute time delay relay.
	Relay, main fan motors	Check for power to coil of motor relay. If no voltage is present, trace wiring back to 20 minute time delay relay. Check for supply voltage to the contact of the relay. If no voltage is present, trace wiring back to power filter. If voltage is present, at the relay coil, check to insure the contacts are closing. Replace relay as needed.
	Hi-limit thermostat(s), control box	Terminals are normally closed, if open, reset thermostat and test oven for proper operation. If it will not reset, replace thermostat.
No main fan cool down	Capacitor(s)	Check for opens, shorts, or grounds.
	Motor(s), main fan	Check for opens, shorts, or grounds.
No main fan cool down	20 minute time delay relay	Check for supply voltage at terminals #1 and #2 while is "ON". Turn "OFF" the main fan switch, supply voltage should continue to be present for 20 minutes. If voltage is not present for 20 minutes, replace 20 minute time delay relay.
	Fan switch	(SEE OVEN FAN WILL NOT RUN.)
	Hi-limit thermostat(s)	Terminals are normally closed, if open, reset thermostat and test oven for proper operation. If it will not reset, replace thermostat.
	Relay, main fan motors	Check for power to coil of oven fan relay. If no voltage is present, trace wiring back to hi-limit thermostat. Check for supply voltage to the contact of the relay. If no voltage is present, trace wiring back to fuse holder. If voltage is present, at the relay coil, check to insure the contacts are closing. Replace relay as needed.
No control box cooling	Cooling fan(s)	Supply voltage should now be at these motors. If voltage is present, check motor for open, shorts, or grounds. WITH POWER OFF: check for locked rotor.
	Incoming power supply	Check circuit breakers, reset if needed. Call power company if needed.
No automatic control box cooling	Incoming power supply	Check circuit breakers, reset if needed. Call power company if needed.

	Cooling fan thermostat(s)	Check the cooling fan thermostat. (Thermostat closes at 49°C and opens at 38°C). With the cooling fan thermostat preheated, check for continuity. If switch is open, replace.
	Fuse, 3 A., cooling fan	Check, replace if necessary.
	Fuse holder	Check, replace if necessary.
	Cooling fan(s)	Supply voltage should now be at these motors. If voltage is present, check motor for opens, shorts or grounds. WITH POWER OFF: Check for locked rotor.
Oven will not heat	Fan switch	Check to see that the fan switch is on.
	Main oven fan	Check if main oven fan is operating. If not, refer to "Oven fan will not run".
NOTE: These ovens utilize 2 complete /Temperature control systems. Each system will Follow the same troubleshooting sequence.		
	Oven control relay	Check for line voltage to the relay coil. If no voltage is present, trace wiring back to the control box hi-limit thermostat(s). If voltage is present, check to insure contacts are closing. Replace relay as needed.
	Thermostat, oven cavity hi-limit	Terminals are normally closed. If open, reset and test oven for proper operation. If thermostat will not hold for maximum oven temperature, and oven is not exceeding maximum temperature dial setting, check for proper location of capillary bulb in its spring holder. If above checks OK, replace hi-limit.
	Contact, hi-limit	Check for line voltage to the contactor coil. If no voltage is present, trace wiring back to the oven cavity hi-limit thermostat(s). If voltage is present, check to insure contacts are closing. Replace contactor as needed.
	Fuse, heater, 50A.	Check, replace if necessary.
	Fuseholder	Check, replace if necessary.
	Control transformer	Check for supply voltage to the primary of the control transformer. If no voltage is present, trace wiring back to the oven control relay. If primary voltage is present, check for 24VAC at the transformer secondary. If there is primary voltage, but no secondary voltage, replace control transformer.
	Oven control	Check for 24VAC supply to control. If no voltage is present, trace wiring back to control transformer. If 24VAC is present, check for a read-out on the control display. If there is 24VAC supplied, but there is no read-out on the control display, replace the oven control. If there is a read-out on the control, set the control to maximum temperature (see installation operations manual for temperature adjustment). With the control set at maximum temperature, check for line voltage at the heat relay (mercury contactor). If there is voltage at the heat relay, proceed to "Heat relay" for next check. If there is no voltage at the heat relay, trace wiring back to the oven control. If there is no voltage output at the oven control, check the read-out on the control. If the control reads "LP FAIL" or "RP FAIL", this indicates that the thermocouple has failed or has become disconnected from the control. "LP FAIL" indicates a problem with the left thermocouple probe, and "RP FAIL" indicates a problem with the right thermocouple probe.

	Thermocouple probe	Check to be sure that the thermocouple is securely connected to the oven control. If the thermocouple is connected to the oven control, and the control indicates "LP FAIL" or "RP FAIL", disconnect the thermocouple from the oven control and measure the resistance of the thermocouple. The left thermocouple should read approx. 21Ω. The right thermocouple should read approx. 11Ω. If these readings are not achieved, replace the thermocouple. If these readings are correct, proceed.
	Oven control	If the thermocouple checks good, but the oven control display indicates that there is a thermocouple failure, replace the oven control. If the oven control indicates a temperature reading but the oven will not heat, proceed.
	Thermocouple	WITH POWER ON AND THERMOCOUPLE ATTACHED TO THE OVEN CONTROL: Measure the DC millivolt output of the thermocouple. Refer to the thermocouple chart (located in the "Removal" section of the manual) for proper millivolt readings. If these readings are not achieved, replace thermocouple.
	Oven control	If the thermocouple checks good, but there is no voltage output to the temperature regulation valve, replace the oven control. If there is voltage output to the heat relay, proceed.
	Oven air pressure switch	Check for supply voltage at the air pressure switch, if no voltage is present, trace wiring back to the oven control. Check for supply voltage on both sides of switch. If voltage is present on one side only, check for air tube blockage. Adjust air pressure switch. If the above fails, replace air pressure switch.
	Heat relay	Check for line voltage supplied to the coil of the heat relay. If no voltage is present, trace wiring back to the air pressure switch. If voltage is present, check to be certain that all of the contacts are closing when the relay is energized.. Also check for opens or shorts in the operating coil. Replace temperature regulation valve as needed.
	Heating elements	Check the Amp draw on each power lead for proper load. Check the specification plate for proper rating information. If the Amp draw is high or low, check the individual heating elements for opens, shorts and proper resistance. To check the resistance of the elements, TURN OFF THE POWER! Remove all wiring from the heating elements and use an accurate digital meter. The element resistance should be as follows: 220V – 29 ohms approx. 230V – 32 ohms approx. 240V – 34 ohms approx. If all readings are not correct, replace heating elements as needed.

Intermittent heating	Thermal overload of main fan motor(s)	The main fan motors are equipped with internal thermal protection and will cease to operate if overheating occurs. As the motors overheat and then cool, this will cause the units to cycle on and off intermittently. Improper ventilation or lack of preventive maintenance may cause this problem. Also, most of the problems listed under "Oven will not heat" can cause intermittent failure.
Conveyor will not run	Power supply	Check for supply voltage at terminals L1 and L2. If voltage is not present check breakers.
	Power switch	Check continuity between switch terminals. Replace switch as needed.
	Fuse, 10 Amp.	Check and/or replace.
	Fuse holder	Check and/or replace.
	Hi-limit thermostat(s), control box	Check for voltage on both sides of the switch. Terminals are normally closed. If open, reset and test for proper operation. If thermostat will not hold, and the control box temperature is not exceeding 140°F (60°C), replace thermostat.
	Relay, oven control	Check for line voltage to the relay coil. If voltage is not present, trace wiring back to the hi-limit thermostat. If voltage is present, check to insure contacts are closing. Replace relay as needed.
	Control transformer	Check for line voltage supply to the primary of the control transformer. If no voltage is present, trace wiring back to the oven power relay. If voltage is present, check for 24VAC at the transformer secondary. If there is primary voltage, but no secondary voltage, replace control transformer.
	Conveyor motor	Check for line voltage supply to the conveyor motor at wire #28 to neutral. If no voltage is present, trace wiring back to the oven power relay. If voltage is present and the motor will not run, check the motor windings for opens or shorts. WITH POWER OFF: Check the motor windings as follows: Grey to black - 116 ohms Grey to brown - 116 ohms Brown to black - 230 ohms
	Capacitor, conveyor motor	Check for shorts or grounds. Replace capacitor as needed. WARNING: Capacitor has a stored charge, discharge before testing.
	Switch, conveyor reversing	Check continuity between switch terminals, Replace switch as needed.
	Oven control	If there is supply voltage to the motor. And the motor, capacitor, and reversing switch check good, replace the oven control.
Conveyor motor runs, but there is no speed display	NOTE: Display will indicate "Belt jam"	
	Oven control	Check for output voltage from the oven control to hall effect sensor (sensor is located in conveyor motor). Measure voltage at the motor connector, red wire and yellow wire. Voltage should be approx. 10VDC. If no voltage is present, trace wiring back to oven control. If there is no voltage present at the oven control, replace the oven control.

	Conveyor motor	If there is voltage supplied to the hall effect sensor, check for a frequency output from the hall effect sensor. Measure frequency across the yellow and white wires at the motor connector. Frequency readings should be approx. 20 – 525 Hz. If these readings are not achieved, replace the conveyor motor. If the readings are achieved, proceed.
	Oven control	If the hall effect sensor readings are correct, but there is no speed indicated on the display, replace the oven control.

REMOVAL, INSTALLATION & ADJUSTMENTS

MODEL SERIES 1621-000-EA, 1628-000-A, 1629-000-A

CAUTION!

BEFORE REMOVING OR INSTALLING ANY COMPONENT IN THE IMPINGER OVEN BE SURE TO DISCONNECT ELECTRICAL POWER AND GAS SUPPLY.

AIR PRESSURE SWITCH – REPLACEMENT

- A. Remove control panel top.
- B. Disconnect wires from switch making note of wire number and location for reinstallation.
- C. Remove air tube from switch assembly.
- D. Remove switch from control box.
- E. Install new switch in reverse, make sure air tube is not blocked or misaligned.

To adjust air pressure switch, remove cover from the switch to expose adjusting screw. To increase sensitivity, turn screw counter- clockwise; to decrease sensitivity, turn screw clockwise.

CONVEYOR DRIVE MOTOR – REPLACEMENT

- A. Shut off power at main breaker.
- B. Remove conveyor.
- C. Remove control panel top and front cover.
- D. Disconnect wiring from motor and mark for reassembly.
- E. Remove sprocket from motor shaft.
- F. Remove 4 screws and remove conveyor motor and mounting bracket.
- G. Remove mounting bracket from conveyor motor assembly.
- H. Reassemble in reverse order.

CAPACITOR, CONVEYOR MOTOR – REPLACEMENT

- A. Shut off power at main breaker.
- B. Remove control box cover and front panel.
- C. Discharge capacitor before removing wires. Mark wires for reassembly.
- D. Remove mounting screw and remove capacitor.
- E. Reassemble in reverse order.

REVERSING SWITCH – REPLACEMENT

- A. Shut off power at main breaker.
- B. Remove control box cover and front panel.
- C. Disconnect wiring from reversing switch and mark for reassembly.
- D. Remove mounting nut and remove reversing switch.
- E. Reassemble in reverse order and check system operation.

REVERSING CONVEYOR DIRECTION

- A. Shut off power at oven switch.
- B. Set reversing switch in the other position.
- C. Turn oven "on" and check for proper operation.

FUSEHOLDER – REPLACEMENT

- A. Shut off power at main breaker.
- B. Remove appropriate control box cover.

- C. Remove 2 wires, note wire number and location.
- D. Remove locknut on backside of fuse holder and push out.
- E. Reinstall in reverse order and check system operation.

THERMOSTAT, HIGH LIMIT, OVEN CAVITY – REPLACEMENT

- A. Shut off power at main breaker.
- B. Remove appropriate control box cover. Remove motor cover and remove oven back to access high limit thermostat sensing bulb.
- C. Remove wires from thermostat, note wire numbers for reinstallation.
- D. Remove mounting nut from high limit thermostat and remove high limit from oven.
- E. Reassemble in reverse order. Check system operation.

ON-OFF SWITCH (POWER) – REPLACEMENT

- A. Shut off power at main breaker.
 - B. Remove control box cover.
 - C. Depress spring clips on side of switch and push out.
 - D. Remove wires from back of switch, note wire number and location.
 - E. Reassemble in reverse order and check system operation.
- NOTE: Make sure switch housing is fully seated in control box housing.

CAPACITOR, MAIN FAN MOTOR – REPLACEMENT

- A. Shut off power at main breaker.
- B. Remove appropriate control box cover.
- C. Remove 2 wires from capacitor, note wire number and location. WARNING: Capacitor has a stored charge, discharge before handling or testing.
- D. Cut 2 tyrapts securing capacitor to base and replace.
- E. Reinstall in reverse order and check system operation.

RELAY – REPLACEMENT

- A. Shut off power at main breaker.
- B. Remove control box cover.
- C. Remove wires from relay, note wire numbers and location for reinstallation.
- D. Remove 2 screws from relay base and replace relay.
- E. Reassemble in reverse order making sure wire connections are properly seated.
- F. Check system operation.

THERMOSTAT, COOLING FAN – REPLACEMENT

- A. Shut off power at main breaker.
- B. Remove appropriate control box cover, remove rear cover.
- C. Remove 2 wires from thermostat, note wire number and location.
- D. Remove 2 mounting screws and replace thermostat.
- E. Reassemble in reverse order and check system operation.

HIGH LIMIT THERMOSTAT, CONTROL BOX – REPLACEMENT

- A. Shut off power at main breaker.
 - B. Remove appropriate control box cover.
 - C. Remove 2 wires from thermostat, note wire numbers and location for reinstallation
 - D. Remove screws from bracket and remove thermostat.
 - E. Reassemble in reverse order and check system operation.
- NOTE: Depress reset button to insure thermostat is set for operation.

COOLING FAN MOTOR – REPLACEMENT

- A. Shut off power at main breaker.
- B. Remove appropriate control box cover.
- C. Remove 4 mounting screws.
- D. Unplug electrical connector and remove fan motor.
- E. Reassemble in reverse order and check system operation.

MAIN FAN MOTOR – REPLACEMENT

- A. Shut off power at main breaker.
- B. Shut off gas supply and remove gas line and manifold lines from back of oven.
- C. Remove screws from motor cover housing and lift off.
NOTE: When ovens are stacked, all motor cover housings are fastened together.
- D. Unplug power connector.
- E. Unplug thermocouple.
- F. Unplug 2 motor connectors.
- G. Remove 8 bolts from oven back (4 left, 4 right) and lift out.
- H. Remove 1 screw from fan hub and slide fan blade off of motor shaft. (note location of fan blade for reinstallation)
- I. Loosen locknuts on cone. Remove 2 mounting bolts and remove motor from back assembly.
- J. Remove 4 hex head screws from motor mount bracket. Remove motor mount from motor and reinstall on new motor.
- K. Reassemble in reverse order. NOTE: 1. Make sure motor is centered in back housing.
2. Verify correct location of fan blade and that it is not hitting fan shroud.
3. Make sure all connectors are properly seated and making good contact.
4. When reinstalling gas manifold across back of oven, check all fittings for leaks.
- L. Check system operation (allow 30 minute preheat for all checks) NOTE: Position of the fan on the motor shaft will be 1.875" from the top of the oven back cone to the blade spider assembly on the fan hub. (see drawing below).

THERMOCOUPLE (TYPE K) – REPLACEMENT

- A. Shut off power at main breaker.
- B. Remove control box covers. Remove motor cover and remove oven back to access thermocouple.
NOTE: Removal of oven back assy. Is required to replace thermocouples.
- C. Remove thermocouple from wire form in oven chamber and remove from chamber.
NOTE: R. H. thermocouple (viewed from front) is connected directly to the temperature control board, remove 2 wires , make note of wire colors and location. When changing L. H. thermocouple (viewed from front, the back motor cover must also be removed to gain access to the thermocouple connector plug.)
- D. Reassemble in reverse order making sure bulb is placed securely in the wire form in the oven chamber.
- E. Check system operation, recalibrate as needed. NOTE: The R. H. and L. H. thermocouples have different connectors on the wire ends and must be ordered accordingly.

THERMOCOUPLE MEASUREMENT

TEMPERATURE (°F)	D.C. MILLIVOLTS
200°	2.8
250°	4.0
300°	5.1
350°	6.0
400°	7.1
450°	8.2
500°	9.3
550°	10.4
600°	11.5

TIME DELAY RELAY – REPLACEMENT

- A. Shut off power at main breaker.
- B. Remove control box cover.
- C. Remove all wires from time delay relay, note wire numbers and location for reinstallation.
- D. Remove mounting screw and remove time delay relay.
- E. Reassemble in reverse order and check system operation.

HEATING ELEMENT – REPLACEMENT

- A. Shut off power at main breaker.
- B. Remove appropriate control box cover.
- C. Remove wires from heating element, note all wire numbers for reinstallation.
- D. Reassemble in reverse order and check system operation. **NOTE:** Be sure that leading edge of heating element is located in heating element mounting bracket, located in oven cavity.

CONTACTOR – REPLACEMENT

- A. Shut off power at main breaker.
- B. Remove appropriate control box cover.
- C. Remove all wires from contactor, note all wire numbers for reinstallation.
- D. Remove mounting screws and remove contactor.
- E. Reassemble in reverse order and check system operation.

POWER FILTER – REPLACEMENT

- A. Shut off power at main breaker.
- B. Remove control box cover.
- C. Remove all wires from the power filter, note all wire numbers for reinstallation.
- D. Reassemble in reverse order and check system operation.

BEARING, CONVEYOR – REPLACEMENT

- A. Remove conveyor from oven and place on a flat work surface.
- B. Remove connecting links from conveyor belting. See Installation and Operating Instructions Manual.
- C. Remove conveyor belting from conveyor. Remove drive sprocket from drive shaft.
- D. Move drive shaft or idle shaft toward end of conveyor, and shaft with bearings will now slip out of holding bracket.
- E. Replace bearing and reassemble in reverse order.

CONTROL TRANSFORMER – REPLACEMENT

- A. Shut off power at main breaker.
- B. Remove wires from primary side, note color and location.
- C. Remove wires from secondary side, note color and location.
- D. Remove two mounting screws and remove transformer.
- E. Reassemble in reverse order and check system operation.

OVEN CONTROL – REPLACEMENT

- A. Shut off power at main breaker.
- B. Remove control box cover and front panel.
- C. Remove all wiring connections and mark for reassembly.
- D. Remove oven control by pulling control from mounting pins. Remove control from oven.
- E. Before installing new control, set voltage jumper (located at the bottom center of the oven control) to the proper (120/240V) position. Install the four push button extensions (included with the oven control) by pushing the extensions onto the four set buttons on control.
- F. Reassemble in reverse order and check system operation.
- G. Set the oven control for the proper operating mode. The 1600 series ovens have dual burner systems. The oven control must be set to the "Dual oven mode". Set control as follows: With the oven power switch "off", depress the "temp" and "down" buttons and turn the oven "on". Control will indicate "Low Pro". Release the buttons, the control will indicate "Temp to store". Press the "temp" button. The control is now set for dual burner operation.

NOTES: All bake times should be within 10 seconds of set bake time, cavity temperature should be calibrated to within 5° of set temperature. For temperature calibration, allow oven temperature to stabilize at least for 30 minutes.

2 BEFORE APPLYING POWER TO OVEN, ENSURE PROPER VOLTAGE JUMPER SETTING FOR 120V or 240V, AND THE 50 HZ / 60HZ JUMPER SETTING IS CORRECT. JUMPERS ARE LOCATED AT BOTTOM CENTER OF CONTROL BOARD.

3 Set digital control for proper oven cavity and conveyor belt during power-up.

A. Single Cavity Ovens - Impinger I or II

Press and hold the 2 inside buttons while turning the power switch on. After Imp. I or II is displayed, release the buttons and control will request the conveyor belt setting - Imp. I or Lo Pro - or Imp. II. The up or down button will toggle between these choices. When desired conveyor belt is selected, press the temp. button to store settings.

B. Dual Cavity Ovens - Impinger Low Profile

Press and hold the 2 outside buttons while turning the power switch on. After Imp. Lo Pro is displayed, release the buttons and control will request the conveyor belt setting - Imp. I or Lo Pro - or Imp. II. The up or down button will toggle between these choices. After the 'Imp. I or Lo Pro' conveyor belt is selected, press the temperature button to store settings.

4 Set digital control for proper temperature scale — F or C

A. Press and hold the 2 RH buttons to enter Sub-Level program. A prompt will be displayed "**Technicians Only**" After a couple seconds a second prompt will say "**Please Release Buttons**" After releasing the buttons, quickly press the **TIME** button and the **UP** button to enter the program. After Sub Set Point is displayed, press temp. button to indicate Scale. The up or down buttons will toggle choices between F or C. After desired scale is selected, allow control to go into normal run mode. **These special prompts are for Prom chips 007 and above.** Prom chips 006 and below, the Sub-Level program can be entered by pressing the two right buttons only.

5 Set bake time and oven temperature — Set Point Menu

A. Press and hold the 2 LH buttons to enter Set Point program. Once in set point program, press temp. button and adjust temperature using up or down arrows. Press time button while still in set point program and adjust time using up or down buttons. Pressing time or temp. button will show what that respective setting is. Once desired settings are programmed, allow control to go into normal running mode.

B. For normal calibration, set bake time to 10:00 and temperature to 500°F/260°C. Bake time can be checked using standard QA procedures. Install cavity temperature probes per standard QA procedures.

6 Adjusting temperature offset — Sub Set Point Menu

A. Follow the instructions in Step 4. to enter the Sub-level program. After Sub Set Point is displayed, pressing the temp. button will access the following temperature features:

SCALE (F or C), HI TEMP, LOW TEMP, OFFSET (+ or -), MANUFACTURE MODE (Clear or Active).

•Do not change SCALE after it was set in step 4A, or settings will reset to default values.

B. To adjust the temperature offset, access the OFFSET display in the Sub Set Point Menu. If cavity temperature is above the set temperature, decrease (down button) the offset value. If cavity temperature is below the set temperature, increase (up button) the offset value. The amount of offset needed should be the difference between the cavity temp. and the set temp. Allow oven to reach set temp. and verify cavity temperature. Readjust offset as necessary.

C. HI TEMP and LOW TEMP are not normally changed unless requested by the customer. Accessing these displays and pressing the up or down buttons will change each indicated setting accordingly.

D. MANUFACTURE MODE is not normally used, so this feature should be set to 'clear'.

E. While in Sub Set Point Menu, pressing the time button will access the following time features: HI TIME and LOW TIME. These are not normally changed unless requested by the customer. Accessing these displays and pressing the up or down buttons will change each indicated setting accordingly.

GENERAL ADVANTAGE SERIES

LETTER	PART #	DESCRIPTION
A	369110	Access window assembly
B	369929	Window retainer
C	369926	Window frame bottom
D	369925	Glass, access window
E	369927	Window frame, top
F	369930	Screw, 10-32x1/4
G	369211	Thumb screw
H	369058	Baffle
J	1609	Oven top
K	370252	Drive cover, R.H.
L	369745	Hinge assy., right
M	369723	Door assy., small
N	369783	Latch, spring
O	369717	Finger retaining bracket
P	369057	Screw, finger retaining bracket
Q	369501	Latch
R	369328	Leg
S	369030	Caster, High stand
	369390	Caster, Low stand
T	370167	Baffle, air return U.L., L.R. (S/N 35950 & below)
	370663**	Baffle, air return U.L. (S/N 35951 & above)
U	370166	Baffle, air return U.R. L.L. (S/N 35950 & below)
	370662**	Baffle, air return U.R. (S/N 35951 & above)
V	370168	Finger housing T-1, T-3, B-2, B-4 (S/N 35950 & below)
	370665***	Finger housing T-1, T-3, B-2, B-4 (S/N 35951 & above)
	370169	Finger housing T-2, T-4, B-1, B-3 (S/N 35950 & below)
	370664***	Finger housing T-2, T-4, B-1, B-3 (S/N 35951 & above)
W		Columnating plates- see Installation Operations manual.
X	369707	Finger cover
Y	369740	Handle assy.
Z	369718	Door assy. , large
AA	369931	Screw, 8-32x3/8
BB	369746	Hinge assy.

**** Units from S/N 35951 and above DO NOT contain lower Air Return Baffles. These units only contain a total of two (2) Air Return baffles which are placed above the top finger assemblies.**

***** These parts have minor changes not shown in the exploded view drawing on page 15.**

GENERAL VIEW

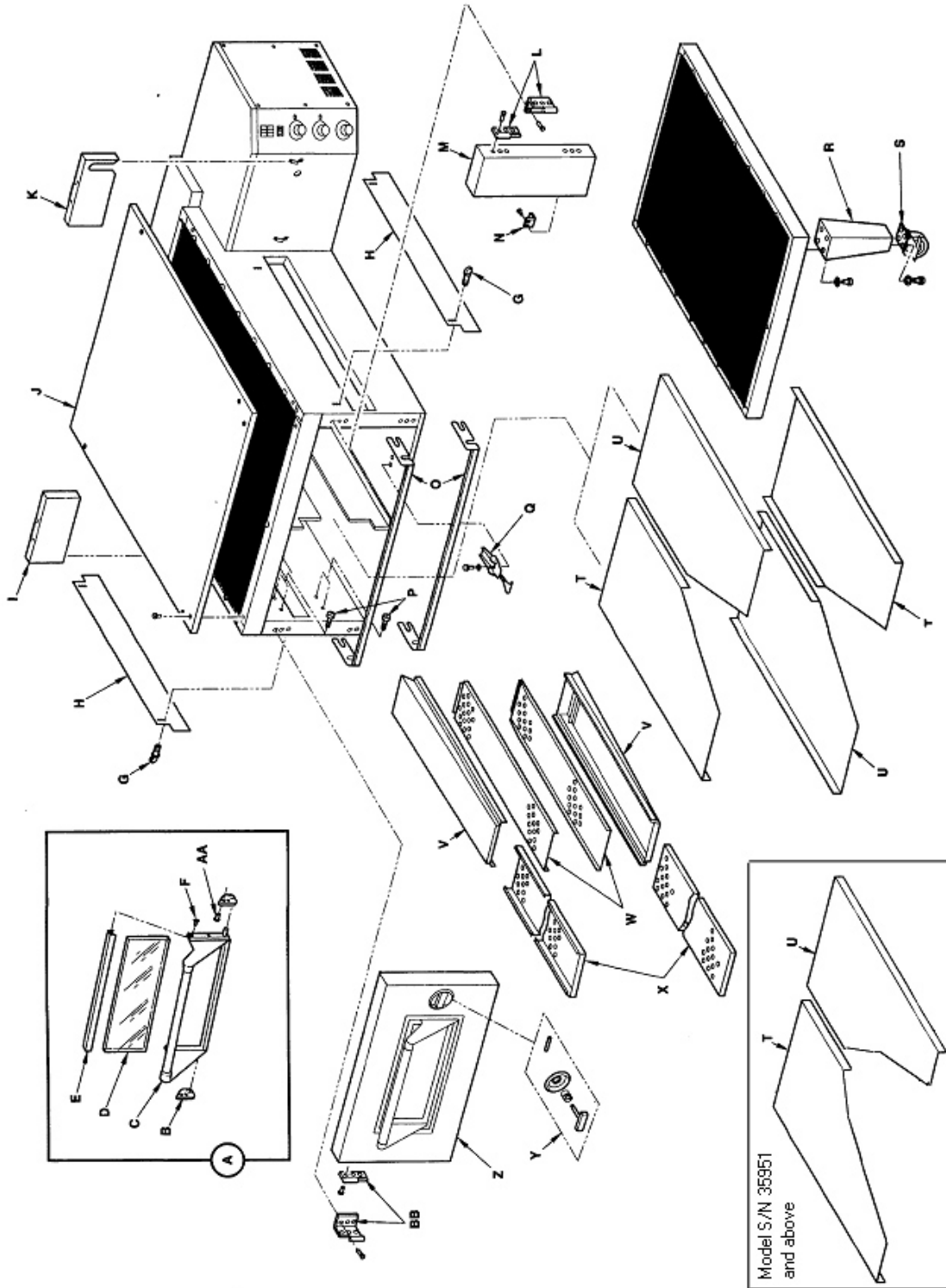

CONTROL BOX, RIGHT
1621-000-EA, 1628-000-A, 1629-000-A

LETTER	PART #	DESCRIPTION
A	9004646	Control Box Front RH
B	369767	Firebar Element, Bottom 220V
	369792	Firebar Element, Bottom 230V
	369769	Firebar Element, Bottom 240V
C	7004973	Mounting Plate Bottom
D	369025	Switch, Blower Air
E	370361	Motor Assembly L/P CE ADV
F	369119	Fuse holder 3 Pole
G	369134	Fuse, 50 A.
H	370117	Terminal Block 5 Pole
I	369378	Cooling Fan Motor 230VAC
J	369766	Firebar Element, Top 220V
	369793	Firebar Element, Top 230V
	369768	Firebar Element, Top 240V
K	7004970	Mounting Plate, Top
L	370251	Top Assembly RH
M	7002976	Capacitor Bracket
N	369192	Capacitor
O	370485	Contactora, Mercury 3P
P	369368	Thermostat, oven cavity hi-limit
R	357107	Fuse Holder
S	369013	Fuse, 3 Amp
	369014	Fuse, 10 Amp
	357107	Fuse holder
T	369431	Thermostat, control box hi-limit
U	369507	Thermostat, cooling fan
V	370241	Transformer 240V-24V
X	370360	Capacitor 230V Digit
Z	7005624	Bracket, Component Assembly
AA	370256	Panel Side Control RH
AB	369125	Terminal Block, 2 Pole
AC	369422	Relay, Fan 240V
AD	370180	Filter EMI
AE	370354	Bush Button Facia
AF	370355	Digital Control Board
AG	369432	Switch, Rocker Lighted
AH	370257	Bracket Gearmotor Mount
AJ	369158	Sprocket, 10 Tooth
Not shown	370357	Thermocouple, right
Not shown	370466	Timer, cool down, 20 minute

CONTROL BOX, RIGHT VIEW

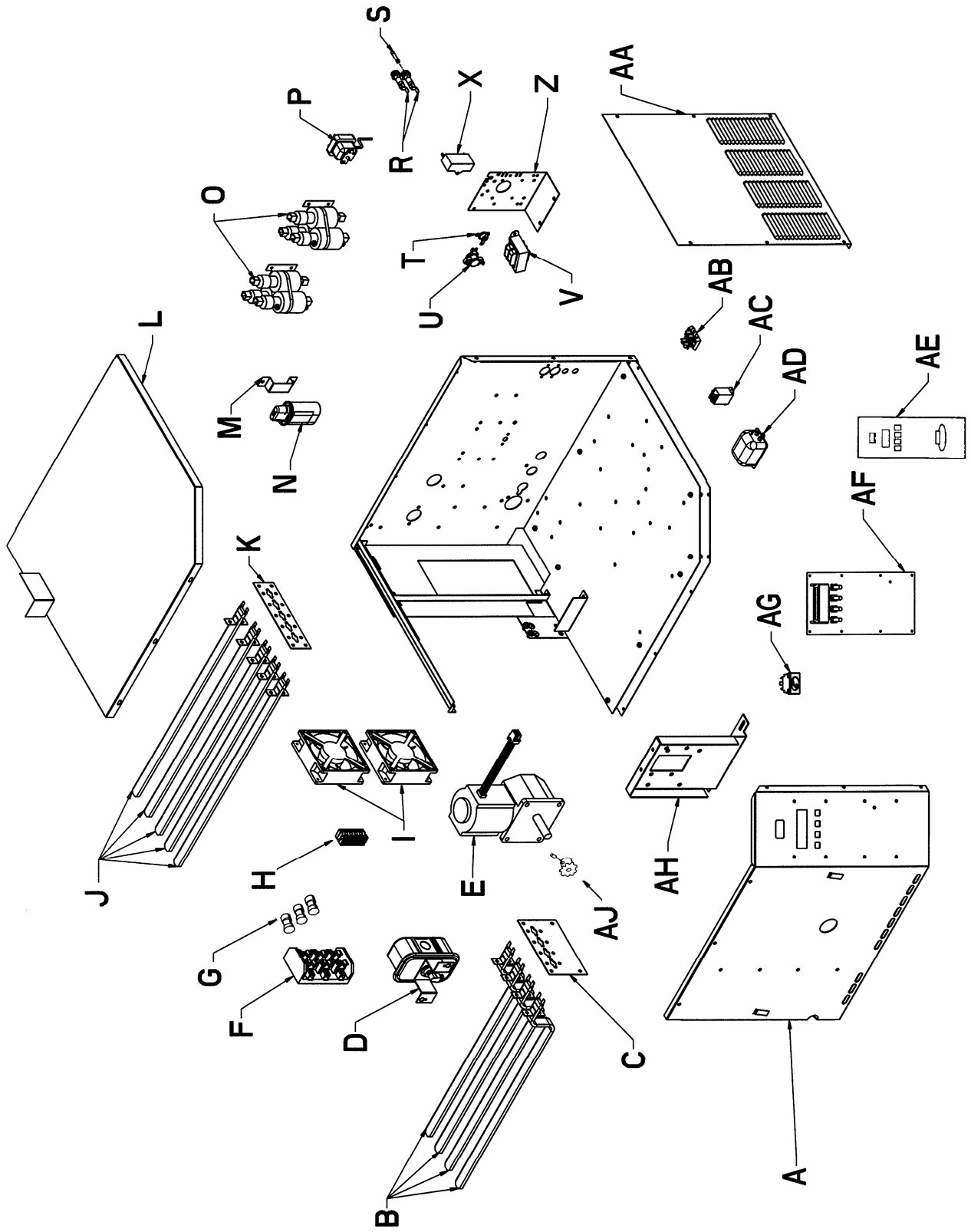

CONTROL BOX, LEFT
1621-000-EA, 1628-000-A, 1629-000-A

LETTER	PART#	DESCRIPTION
A	7006233	Control Box, Back LH
B	370250	Top Assembly LH
C	369378	Cooling Fan Motor 230VAC
D	370495	Bracket Fan RH
E	369766	Firebar Element, Top 220V
	369793	Firebar Element, Top 230V
	369768	Firebar Element, Top 240V
F	7004970	Mounting Plate, Top
G	369767	Firebar Element, Bottom 220V
	369792	Firebar Element, Bottom 230V
	369769	Firebar Element, Bottom 240V
H	7004973	Mounting Plate, Bottom
I	7006234	Control Box, Front LH
J	369025	Air Switch, Blower
L	370272	Panel, Control Box Side LH
M	369507	Thermostat, cooling fan
N	369431	Thermostat, control box hi-limit
O	7005624	Bracket Component
P	370485	Contactora, Mercury 3P
R	369368	Thermostat, oven cavity hi-Limit
S	7002976	Bracket Capacitor
T	369192	Capacitor 7.5 MFD
Not shown	370358	Thermocouple, left

CONTROL BOX, LEFT VIEW

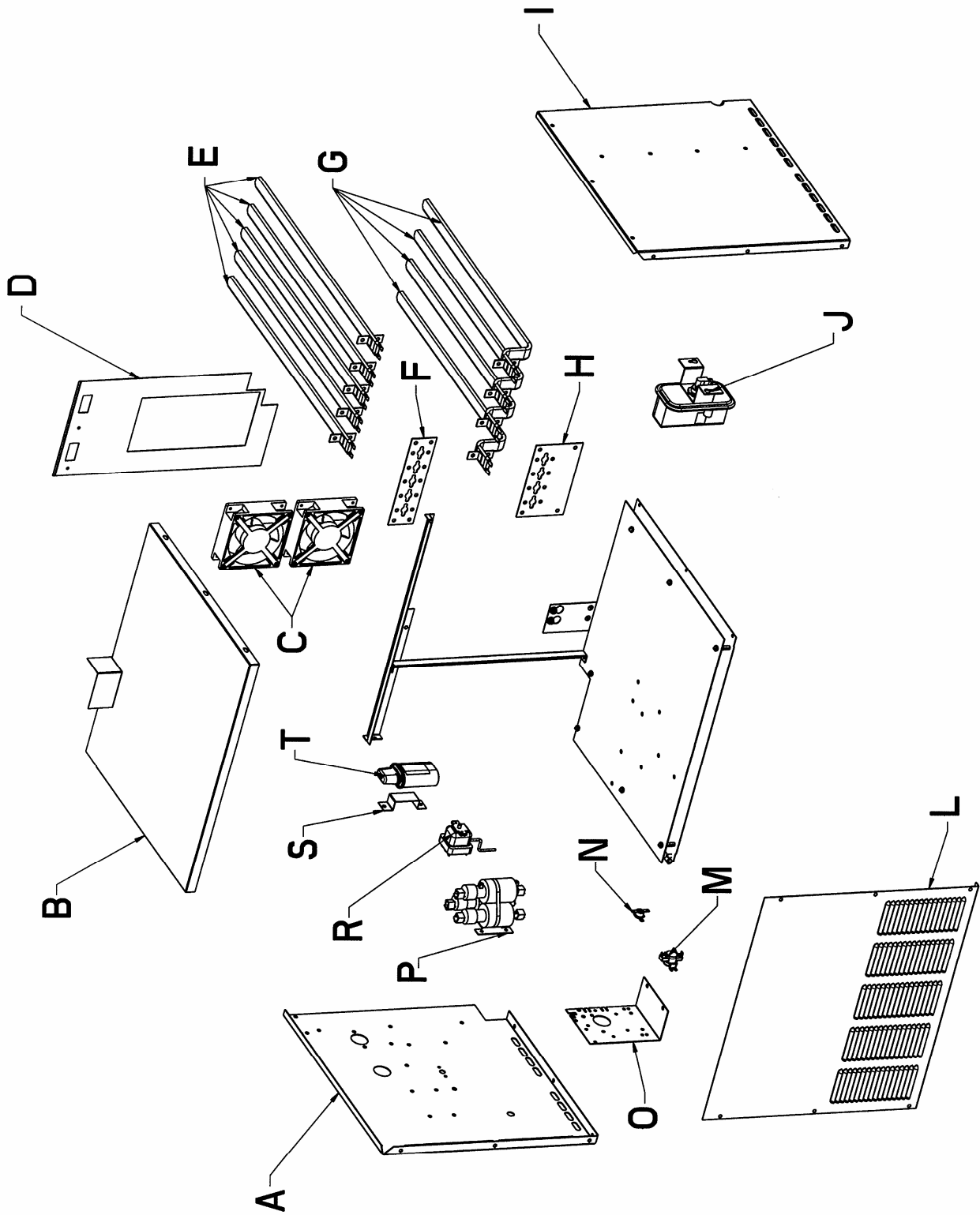

OVEN BACK
1621-000-EA, 1628-000-A, 1629-000-A

LETTER	PART#	DESCRIPTION
A	369547	Wire form thermostat bulb
B	369725	Fan, clockwise rotation
C	369776	Fan shroud
D	369777	Stand-off
E	369778	Rear wall assy.
F	369761	Motor mount
G	369759	Motor, main fan 220/240V 50 Hz.
H	1627	Duct cap
I	369033	Motor clamp
J	370245	Rear duct
L	369724	Fan, counter-clockwise rotation

CONVEYOR

1621-000-EA, 1628-000-A, 1629-000-A

LETTER	PART#	DESCRIPTION
A	369830	Complete conveyor
	369002	Knob, conveyor tension
	369362	Belt, 1ft. section (32 inch wide belt)
B	369314	Roll, conveyor, notched
C	2114003	nut, hex
D	369812	Conveyor idler shaft
E	369160	Conveyor pan stop
F	369641	Bracket, idle bearing
G	369220	Bearing, idle
H	369005	Connecting link (32 inch wide belt)
I	369811	Conveyor drive shaft
J	369161	Roller chain sprocket
K	369813	Conveyor bearing block
L	369825	Retaining ring
M	370247	Drive chain
N	370050	Conveyor frame
O	369806	Crumb pan
P	369163	Conveyor belt, complete (32 inch wide belt)

CONVEYOR VIEW

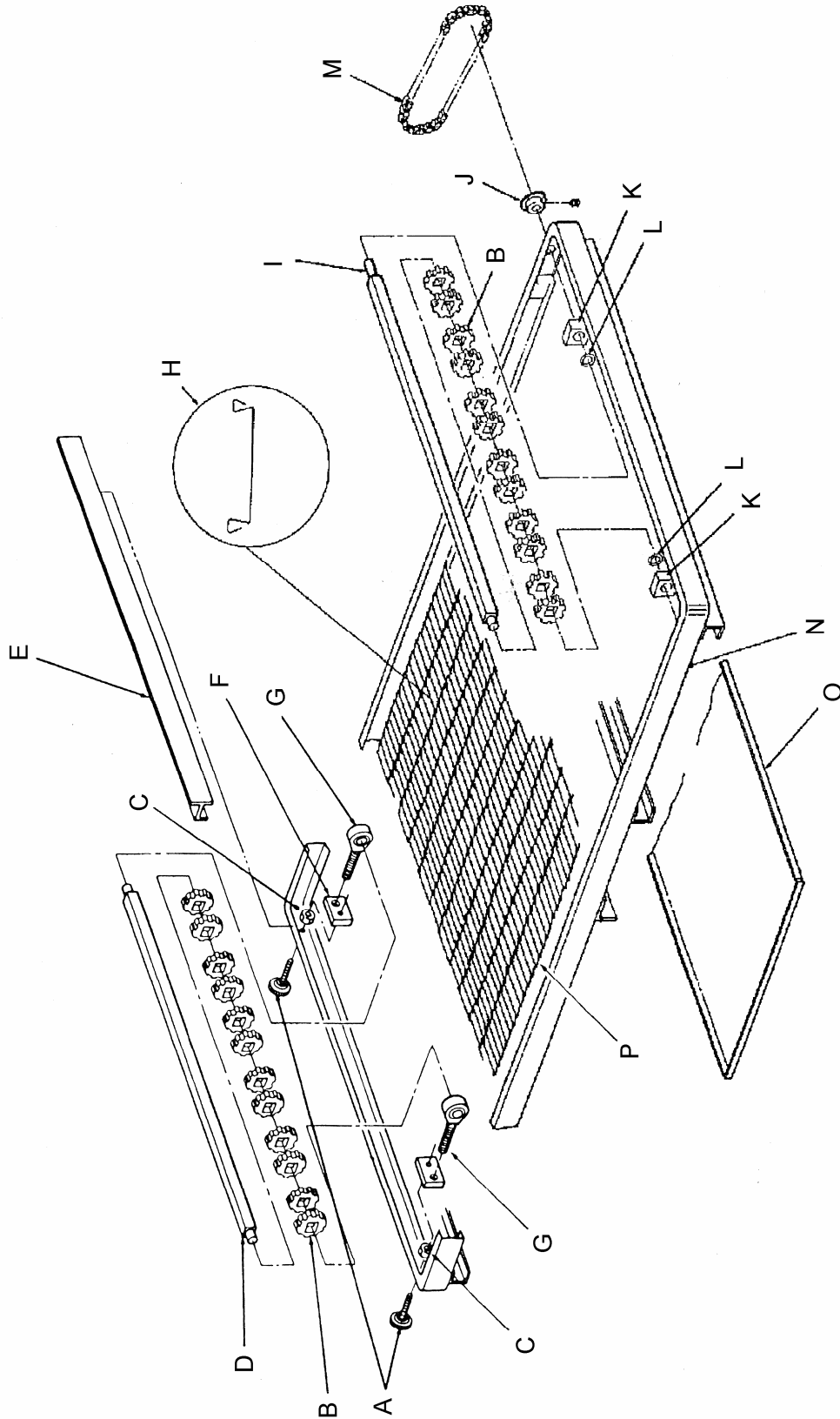



Free Manuals Download Website

<http://myh66.com>

<http://usermanuals.us>

<http://www.somanuals.com>

<http://www.4manuals.cc>

<http://www.manual-lib.com>

<http://www.404manual.com>

<http://www.luxmanual.com>

<http://aubethermostatmanual.com>

Golf course search by state

<http://golfingnear.com>

Email search by domain

<http://emailbydomain.com>

Auto manuals search

<http://auto.somanuals.com>

TV manuals search

<http://tv.somanuals.com>