

APPLICATION

WAVEFORM CONTROL TECHNOLOGY™

Tandem MIG™

High-Speed and High-Deposition Welding

Low cost and profitability are key business objectives, whether the product offering is a wheel, a water tank, or a truck frame. It used to be thought that on the road to lower cost, quality had to be sacrificed. That's no longer true with Tandem MIG welding.

The following factors affect pricing per welded part:

- Capital Equipment
- Overhead
- Labor cost
- Part production rates

Lincoln Tandem MIG welding systems are designed to produce quality welds at welding speeds well above accepted single wire processes. The unique engineered output control of the Tandem MIG dual wire process is designed to overcome the barriers limiting the travel speed capabilities of conventional single wire GMAW processes.



Fast travel speeds on thin lap welds increase the number of parts per day.

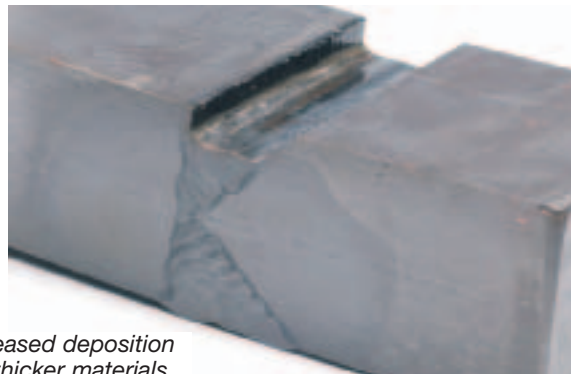

Increased deposition on thicker materials reduces welding time and distortion.

a d v a n t a g e s

INCREASED TRAVEL SPEEDS

- The combined contribution of two separate welding arcs in one weld pool provides the control to overcome the lack of follow tendencies of single arc processes.

INCREASED DEPOSITION

- Two small diameter Tandem MIG wire electrodes provide higher melt-off rates per current drawn when compared to a single larger diameter wire electrode at similar current draws.

IMPROVED THROUGHPUT

- Higher travel speeds and higher deposition rates reduce part welding time cycles.

Tandem MIG

2/16

High-Speed and High-Deposition Welding

What Is It?

Tandem MIG is a dual wire GMAW process that is used in automated welding applications to improve welding productivity and part throughput. The process utilizes two welding power sources and two wire feeders acting in tandem to deliver two wire electrodes through a single welding torch. The dual wire welding torch, capable of often doubling the welding output of a single wire torch, is used in hard automation and robotic arc welding cells in the same manner as a single wire welding torch would be. The two welding arcs that are generated in the Tandem MIG process are electrically isolated from one another and are

controlled independently. The welding arcs work together, generally separated by less than 0.50 inches, in the same weld pool. The independent control of the two welding arcs is used to control the thermal and fluid dynamics of the weld pool to further enhance welding performance. The added deposit rate achieved by the dual wire delivery and the added weld pool control is used to overcome single wire limitations to produce high travel speeds and electrode melt-off rates (weld metal deposition). Special power source welding software is used to allow the two welding arcs to operate in unison.

Tandem MIG Configuration

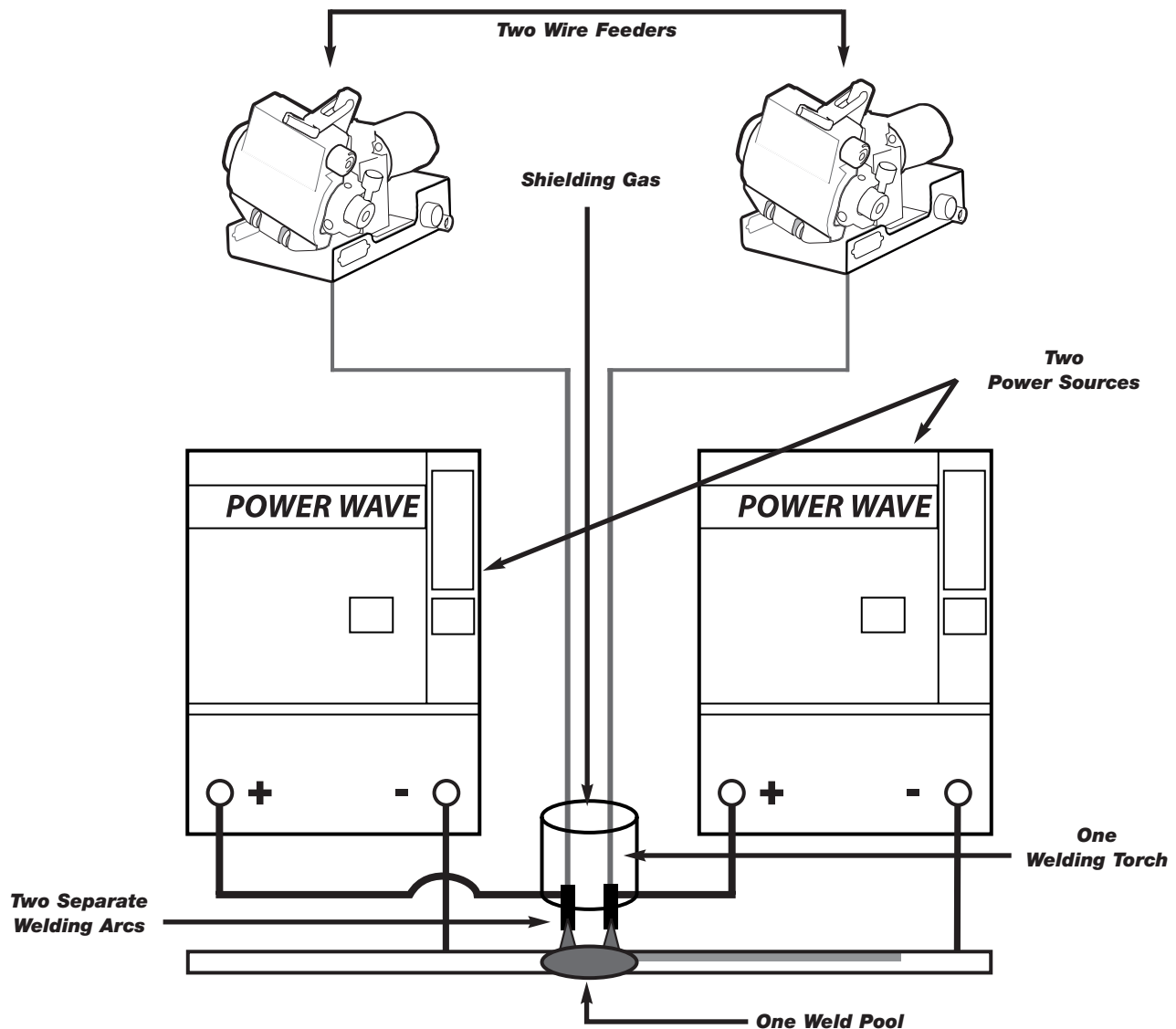

Tandem MIG

High-Speed and High-Deposition Welding

How Does It Work?

The two welding arcs common to the Tandem MIG process have distinct functions. The lead arc (the first arc in the direction of torch travel) is operated in a spray transfer mode. The mode may be either a special Tandem MIG pulse mode, an adaptive constant voltage mode or a Tandem MIG power mode. The lead arc's primary function is to establish initial root penetration and develop a molten weld pool for the trail wire. While performing these functions the lead wire typically accounts for 60% or more of the total weld metal deposited. The trail arc or second arc

is operated in a special Tandem MIG pulse mode. The trail arc's function is to add filler metal to the weld pool and control the bead characteristics such as edge wetting, physical contour, side-wall penetration and weld pool follow speed. The trail arc should be kept directly in line with the lead arc and focused on the center of the weld pool. The trail wire melting rate typically represents approximately 40% of the process deposition rate. The Tandem MIG trail pulse waveforms are designed to operate at low voltages to limit arc interaction and minimize arc blow.

Lead and Trail arc functions for high speed welding

Trail arc is focused on the crest of the pool created by the lead.

Lead and Trail arc functions for high deposition welding

The trail arc is focused on the middle of the weld pool to create additional fill.

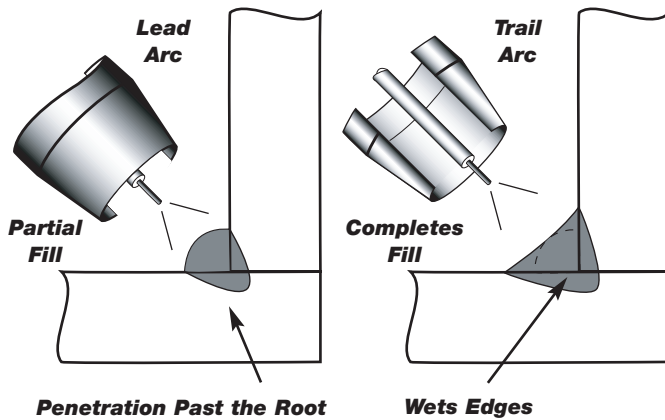
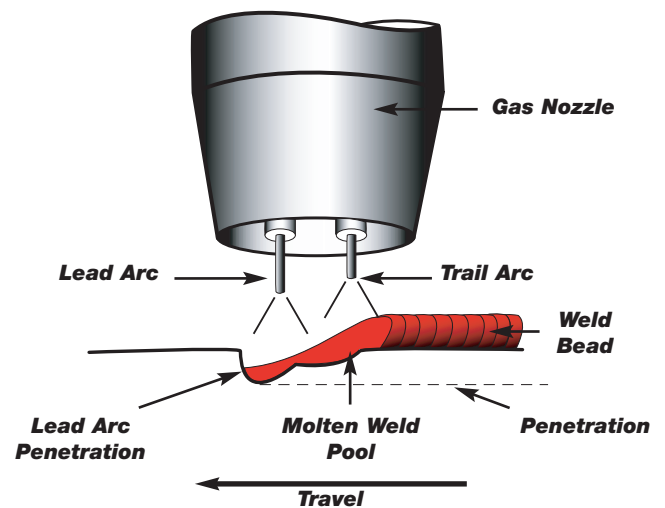
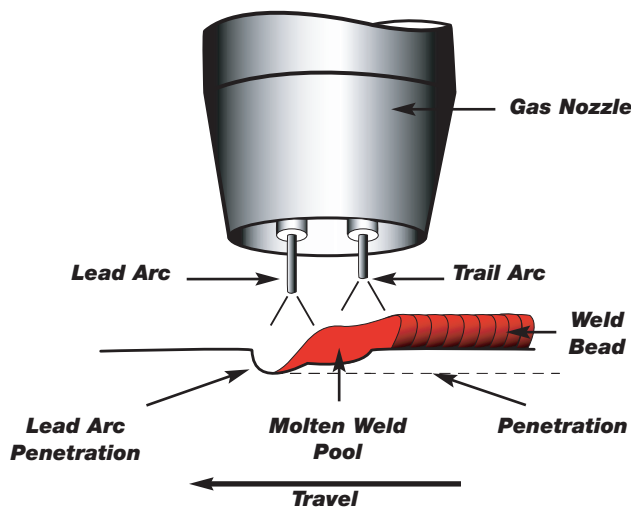

The Lead Arc generates the majority of the penetration and leaves joint requiring additional fill.

The Trail Arc places a downward and forward pressure on the weld pool for better pool follow and wetting along the bead edges.

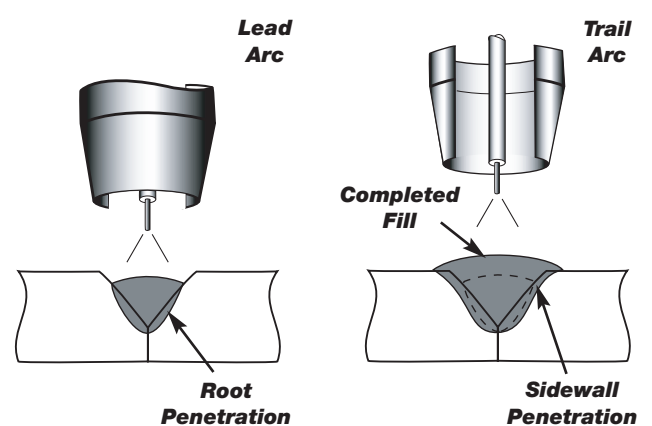

The Lead Arc creates the initial root penetration and the majority of the joint fill.

The Trail Arc is focused in the weld pool providing additional joint side-wall penetration and joint fill.

Tandem MIG

4/16

High-Speed and High-Deposition Welding

Using Tandem MIG

For High-Speed Applications

Flat and Horizontal Lap Welds 1.5 mm - 5 mm

Automotive, Tank Fabrication

Flat and horizontal lap welds common to automotive components like control arms, stub or full chassis frames, cross members, shock absorbers, struts, stabilizer arms and flex axles are performed at welding travel speeds ranging from 70 - 130 ipm. On thinner components with metal thickness ranging from 1.5 - 3 mm, flat and horizontal lap welds are made with (2) .035" diameter electrodes at travel speeds ranging from 100 - 130 ipm. Thicker components with metal thickness from 3 - 5 mm are performed with (2) .045" diameter electrodes at travel speeds ranging from 70 - 100 ipm.

Flat and Horizontal Fillet Welds 3 mm - 6 mm

General Light Gauge Steel Fabrication, Shipbuilding, Railroad

Light gauge steel fabrication of 3 - 4 mm fillet welds used to weld structural trusses, farm implements, residential and commercial storage systems, trash-hauling containers and similar components are welded with (2) .035" diameter electrodes to produce welds at travel speeds ranging from 80 - 100 ipm. Larger 4 - 6 mm fillet welds common to structural beams, light earth moving equipment, ship stiffeners, rail cars and similar components are welded with (2) .045" electrodes at travel speeds ranging from 50 - 80 ipm.

Joggle Joints 1.5 mm - 4 mm

Tanks and General Fabrication

Joggle joints require a careful balance of joint fill and controlled penetration. Tandem MIG provides the independent control of both, providing needed joint fill without excessive penetration. Joggle welds between 1.5 and 3 mm, common to the light tank, truck bodies, trash-hauling containers and similar components are welded at travel speeds ranging from 80 - 120 ipm using (2) .035" diameter electrodes. Larger 3 - 4 mm joggle joints used in larger tanks and thicker containers are performed at welding speeds ranging from 40 - 80 ipm using (2) .045" diameter electrodes.



This thin gauge lap weld was made at a travel speed of 100 ipm



3/16" (4.8 mm) Horizontal Lap Weld

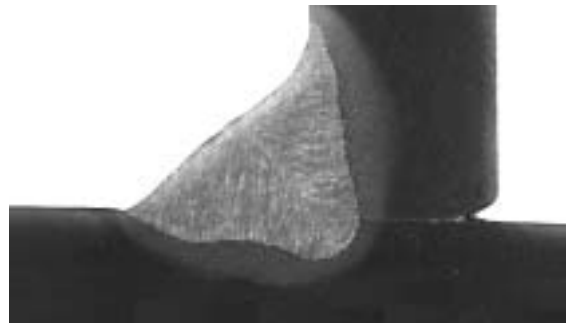

6mm Horizontal Fillet



Joggle Weld

Tandem MIG

5/16

High-Speed and High-Deposition Welding

Using Tandem MIG

For High-Deposition Applications

Flat and Horizontal Fillet Welds 6 mm and Larger

**Railroad, Structural, Industrial
Equipment, Ship Building, Off Road
Wheel Manufacturing**

Flat and horizontal fillets common to structural building components, offshore platforms, railcar haulers, machine bases, large vehicle wheels, undercarriages/truck suspensions and other fabricated components of metal thickness of 6 mm and greater are performed at deposition rates ranging from 21 - 35 lbs./hr.

Single pass 5/16" flat fillets are commonly welded at 24 - 30 ipm with (2) .045" diameter electrodes.

Single pass 5/16" flat fillets are commonly welded at 27 - 40 ipm with (2) .052" diameter electrodes.

Bevel and "V" Groove Joints

**Heavy Plate Fabrication, Structural
Members and Industrial Equipment**

Single and multi-pass beveled butt welds used in industries fabricating ship hulls, earth moving equipment, structural platforms, pressure vessels, beams and similar heavy plate weldments are performed at deposition rates ranging from 22 - 35 lbs./hr. Welds are commonly performed using like electrode diameters, either .045 or .052 inch diameter. The lead electrode provides root penetration, the trail electrode adds to sidewall penetration.

"J" and "U" Groove Butt Welds

**Earth Moving Equipment and
Heavy Plate Fabrication**

Single and multi pass "J" and "U" groove joints common to undercarriages, rollover protection equipment, sticks, booms, fifth wheels, frames, hydraulic cylinders, pant legs and similar earth moving equipment components are welded at deposition rates ranging from 22 - 35 lbs./hr. Welds are performed at a 30 - 50% reduction in heat input when compared to larger diameter single electrode processes. Lower heat input can substantially reduce post weld straightening activity caused by distortion.

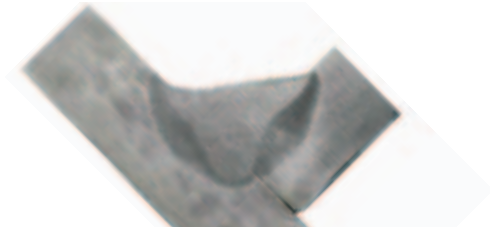

1/2" Flat Fillet at 20 ipm

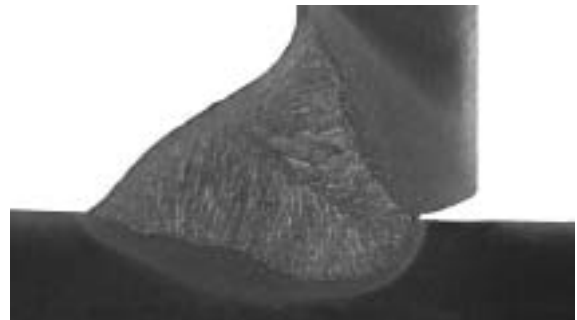

8 mm Horizontal Fillet



Multi-pass Butt Weld

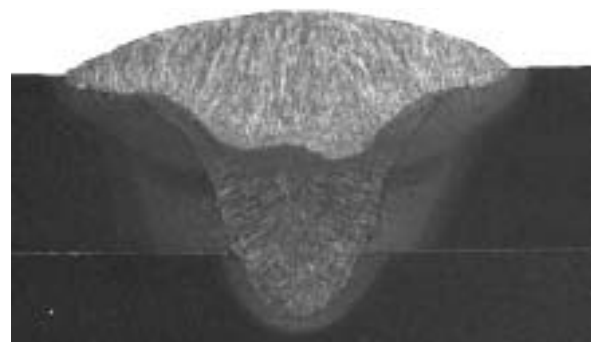

2 Pass "J" Groove

Tandem MIG

6/16

High-Speed and High-Deposition Welding

Comparing High-Speed Tandem MIG

To Single Wire GMAW Processes

Better Weld Metal Follow Characteristics:

Problem - Single Wire GMAW

As higher travel speeds are explored with conventional single solid and metal cored wire GMAW processes one of the factors that limits obtainable travel speeds is a phenomenon referred to as “bead humping” or lack of follow. The lack of follow occurs as a number of physical metal flow requirements break down. The coalescent properties of the weld pool are not strong enough to pull the puddle along while, at the same time, the higher travel speeds limit the heating of the plate that would normally allow the weld pool to wet or flow along the weld bead edges.

Solution - Tandem MIG

The spacing of the two arcs of the Tandem MIG process is designed to overcome the lack of follow associated with single wire GMAW processes. The lead arc provides initial penetration into the base plate and a preheating of the plate for the trail arc. The trail

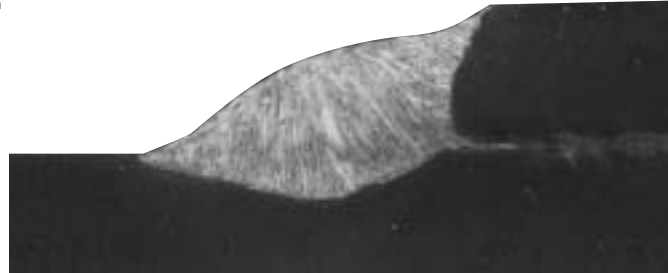

12 Gauge Lap Weld
at 120 ipm travel

arc rides the pool created by the lead electrode, the pressure from the trail arc flattens the created weld pool to eliminate the tendency for the pool to rise and hump. The applied weld pool pressure from the trail arc is used to not only limit the tendency of the lead weld pool to hump and lose follow capability, but the pressure is adjustable, allowing the bead contour to be modified to meet application requirements.

Reduced Tendency Towards Burn-through and Undercut

Problem - Single Wire GMAW

Increased travel speeds require the use of larger wire diameters or higher wire feed speeds. Both choices will cause an increase in current draw. The added current draw creates added penetration that must be managed. With a single wire GMAW process the penetration is most intense at the point where the axial flow of material from the welding wire is directed on to the plate. This area is focused to a small area that is generally the cross-sectional area of the welding wire diameter. In order to manage the additional finely focused penetration wire placement becomes more demanding, joint fit-up becomes more critical. If joint alignment is not maintained and the welding arc wanders off the seam, concentrating the arc on a single metal thickness, burn-through is a common result. If joint fit-up is not maintained welds often penetrate well into the open joint creating an unacceptable undercut. If the penetration is not successfully managed the common result is costly increased rework or scrap.

Solution - Tandem MIG

The Tandem MIG process is able to achieve the high wire feed requirements of high speed welding without creating excessive penetration. The required wire feed total for high speed welding is shared by the two electrodes forming the Tandem MIG process. The shared wire feed speed not only reduces the current draw on each individual arc but disperses the total welding energy over two separate focal points. The separation of the two focal penetration points allows more metal to be deposited without excessive penetration. The lead arc is focused on the plate while the trail arc is focused on the molten pool created by the lead arc. The trail wire energy is applied to the pool and not directly onto the plate. This limits the overall penetration and allows the process to be tolerant of joint misalignment and joint gaps.

Tandem MIG

7/16

High-Speed and High-Deposition Welding

Comparing High-Speed Tandem MIG

To Single Wire GMAW Processes

Travel Speed Comparison

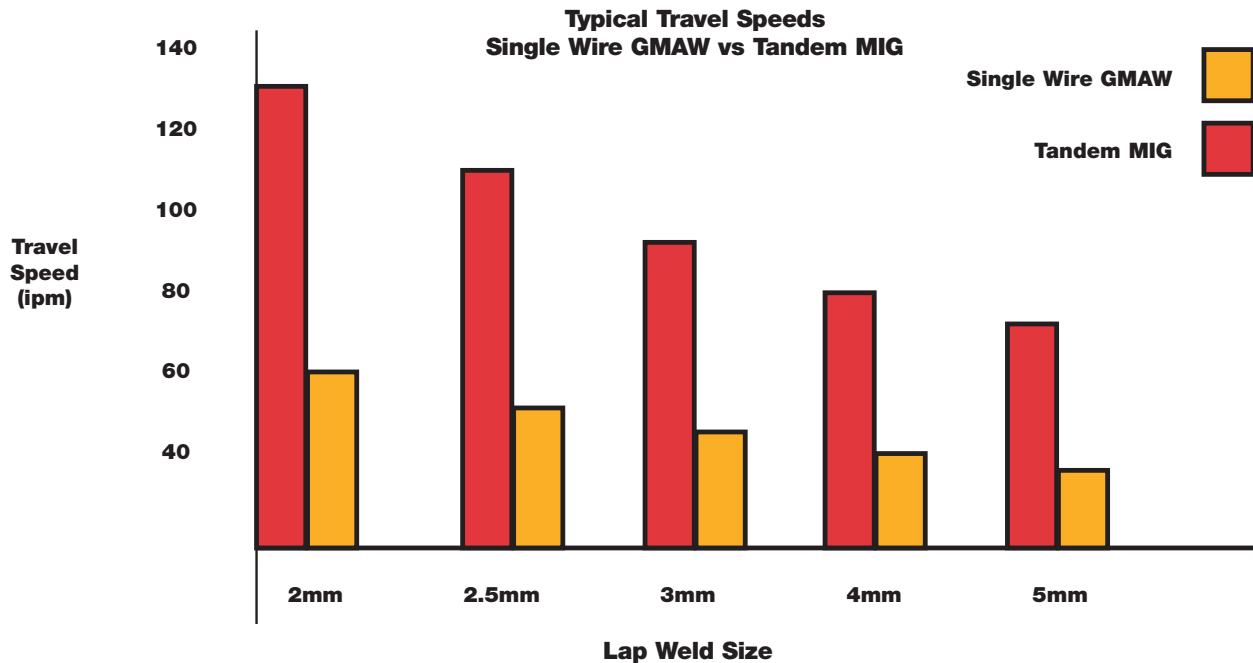

Comparing High-Deposition Tandem MIG

To Single Wire GMAW Process

Higher Deposition rates

Problem - Single Wire GMAW

A conventional single wire GMAW process has an optimum operating range based primarily on wire diameter, shielding gas and wire feed speed. Attempting to maximize deposition rates for a given wire diameter requires increasing the wire feed rate to the top or beyond its defined operating range. As the process is pushed to its limit, arc instability is often a result. Arc instability creates increased spatter levels and weld porosity. The elevated welding currents create weld pool turbulence that can cause root porosity, or porosity just below the surface of the weld bead.

Solution - Tandem MIG

The two-wire electrode configuration of the Tandem MIG process allows a higher total wire feed rate, creating a higher deposition rate. Each electrode in the Tandem configuration can be operated within an optimum operating range as defined by a single wire



process. Both the lead and the trail electrode may be operated in a stable operating range, while the combined wire feed speed of the two electrodes often exceed a useable single wire process by 35-80%.

Tandem MIG

8/16

High-Speed and High-Deposition Welding

Comparing High-Deposition Tandem MIG

To Single Wire GMAW Process

Reduced Heat Input and Improved Bead Profiles

Problem - Single Wire GMAW

A single wire GMAW process has a useable weld metal deposition rate based on wire feed speed and wire diameter. In an attempt to increase weld metal deposit rates, rather than push a given wire diameter to unstable wire feed speeds, it is often common practice to increase the wire diameter and operate within stable wire feed ranges. The increase in wire diameter increases the required current draw associated with a given weld metal deposit rate. Increased current draw produces higher heat inputs leading to part distortion and a large fluid weld pool that is difficult to control.

Solution - Tandem MIG

With the Tandem MIG process the two smaller diameter electrodes produce a lower heat input and improved weld pool control when compared to a larger single electrode process attempting to perform similar welds. When compared to larger diameter electrode processes, Tandem MIG typically reduces heat input by as much as 30-50%. The trail electrode in the Tandem MIG process is operated in a special Tandem MIG pulse mode designed to cool the weld pool created by the lead electrode. The combination of lower total heat input and the cooling affect of the trail electrode, allows the trail electrode to be used to help control weld bead contour. This provides the ability to better stack horizontal weld beads and produce flatter horizontal fillets while working at higher deposition rates.

REDUCED HEAT INPUT EXAMPLE

5/16" Horizontal Fillet Weld					
PROCESS	CURRENT DRAW (amps)	ARC VOLTAGE (DC+)	DEPOSIT RATE (lbs./hr)	TRAVEL SPEED (ipm)	HEAT INPUT Kj/in
GMAW - 1/16" dia. - ER70S - 6	470	31	17.8	17.7	49.4
FCAW - 3/32" dia. - ER70T - 1	435	29.5	15.8	15.7	49.0
GMAW - 3/32" dia. - ER70C - 6M	500	34	16.2	16.1	63.3
Tandem MIG					
Lead .045" dia. ER70S - 6	300	23	23.3	23.1	33.5
Trail .045" dia. ER70S - 6	250	24			

Tandem MIG

High-Speed and High-Deposition Welding

Comparing High-Deposition Tandem MIG

To Single Wire GMAW Process

Deposition Rate Comparison

Weld Metal Deposition Rate Single Wire GMAW vs Tandem MIG

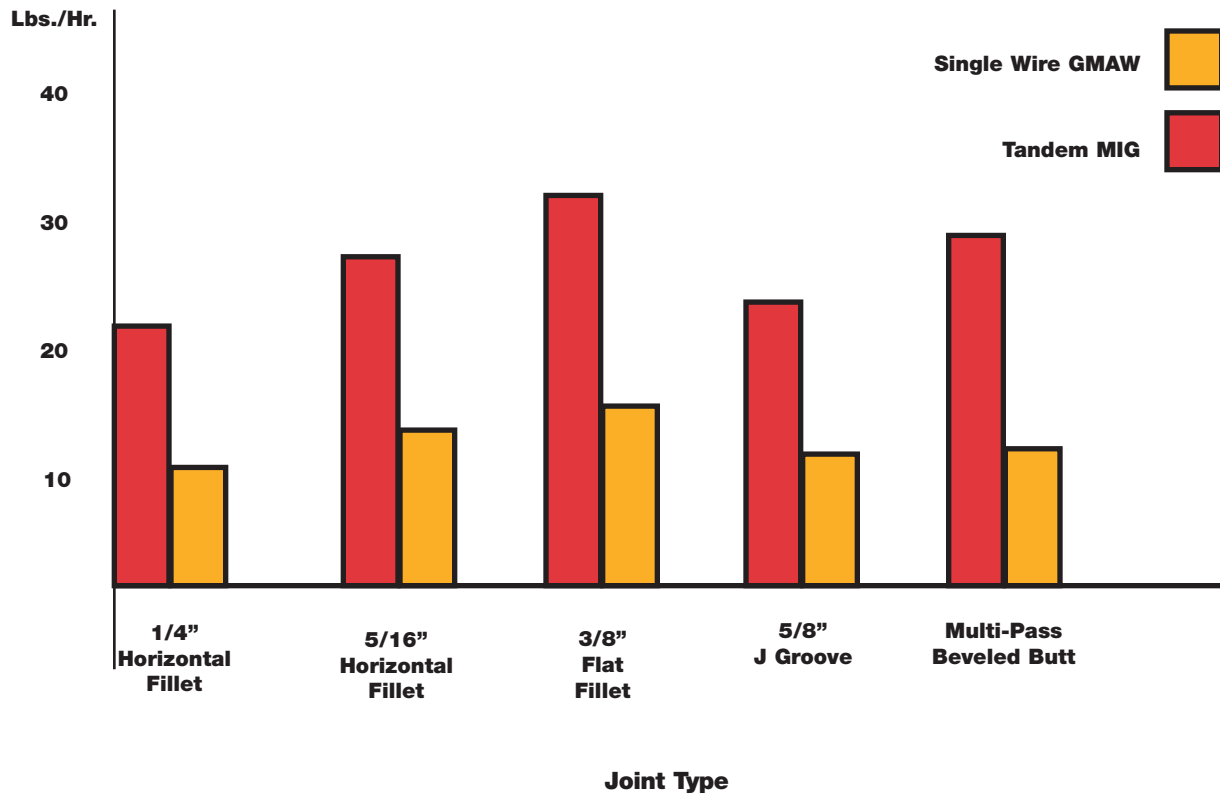

Tandem MIG

10/16

High-Speed and High-Deposition Welding

Using Tandem MIG

Understanding Operating Variables

The general rules governing operating variables for single wire GMAW arc welding also apply to Tandem MIG welding. However there are additional considerations that must be kept in mind when welding with multiple arcs. Since the two arcs will interact, the type of power fed to each arc, the wire feed speed ratio between lead and trail, the arc lengths, the wire positioning, and torch angles must be set correctly. The enclosed procedures are starting points and may need to be altered based on specific application conditions. Adherence to the following guidelines will assist in achieving the maximum potential of the process.

Lead Arc

The lead arc creates the majority of the penetration and should represent the majority of the total deposition rate of the process. When using like diameter electrodes for the lead and the trail, the lead should represent approximately 60% of the total wire feed. In the case where a larger wire diameter is used as a lead (for added penetration) the lead should represent approximately 60% or more of the total deposition. The lead arc can be operated in a Tandem pulse, CV or Power mode. Pulse is recommended for the high deposition procedures. Power mode or CV may be used for greater lead arc stability in high travel speed applications.

Trail Arc

The trail arc is used to cool the weld pool and control the bead contour and is always operated in the Tandem pulse mode. The trail should be kept directly in line with the lead arc and focused on the center of the weld pool. The trail wire should represent approximately 40 % of the process deposition rate. The Tandem MIG trail pulse waveforms are designed to operate at low voltages to limit arc interaction and minimize arc blow.

Torch Positioning

Torch positioning may be altered for specific applications. A 5-degree push angle is recommended for high deposition welding. A (0-5)-degree angle is recommended for high speed welding.

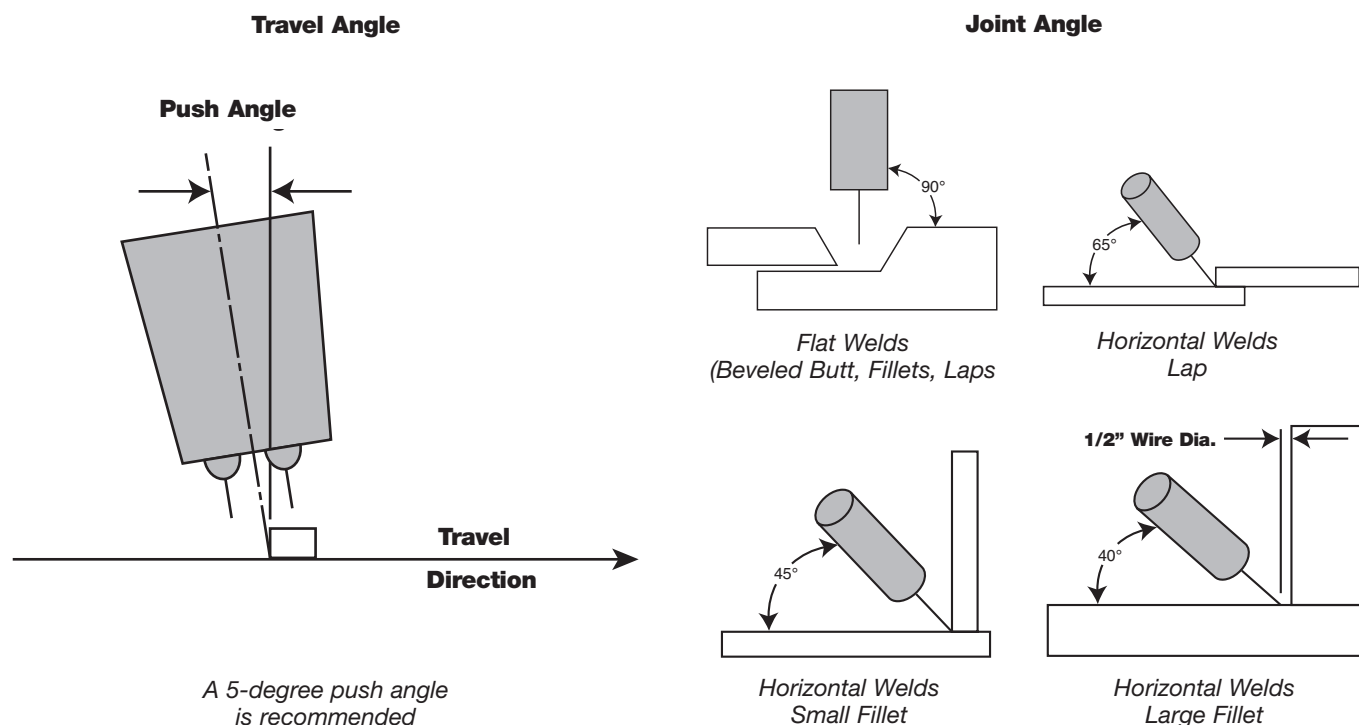

Tandem MIG

11/16

High-Speed and High-Deposition Welding

Using Tandem MIG

Understanding Operating Variables

Shielding Gas

The lead and trail shielding gas should be of the same mixture and supplied through separate flow regulators. Gas flow per electrode should be a minimum of 40-cfh each. High deposition procedures may require flow rates as high as 70 cfh per electrode. High deposition multi-pass applications may require that a trailing gas is applied to eliminate nitrogen pick-up. The Tandem MIG process requires a binary gas mixture capable of supporting a spray transfer. Argon/Carbon dioxide or Argon/ Oxygen are the preferred mixtures.

1. 90/10%, Ar/CO₂ is preferred for most welding applications.
2. 82-95% argon with a Ar/CO₂ binary mixture is a useable range, The higher CO₂% will promote added penetration but may produce added spatter. The lower CO₂ % will produce less spatter.
3. 95/5%, Ar/O₂ is recommended for high speed welding of thin gage material under 3mm. The mixture will provide improved wetting at bead edges and reduced tendency to erode away edges of lap welds.

Work Lead Connection

Tandem MIG welding should be performed welding in the direction from the work lead connection. Welding towards the work lead connection may cause a convex weld bead and undercut.

Joint Selection

The Tandem MIG process is ideal for many joint configurations. A joint application rating is as follows:

Excellent

1. Lap welds in the flat, horizontal, 3 o'clock position.
2. Fillet welds in the flat and horizontal positions.
3. Joggle welds in the flat position.
4. Beveled butt welds in flat position.
5. "J" Groove welds.
6. Rotated roundabouts, lap and joggle welds.

Good

1. Beveled butt welds in horizontal position.
2. Horizontal flare joint.

Poor

1. Seamer applications.
2. Joints known to be subject to arc blow.
3. Weld joints that have multiple or severe turns in direction or contour.
4. Thin gage square edge butt welds.

Tandem MIG

High-Speed and High-Deposition Welding

Configuring Tandem MIG

Hard Automation Systems

Models: AD1202 - 1 and AD1202 - 2

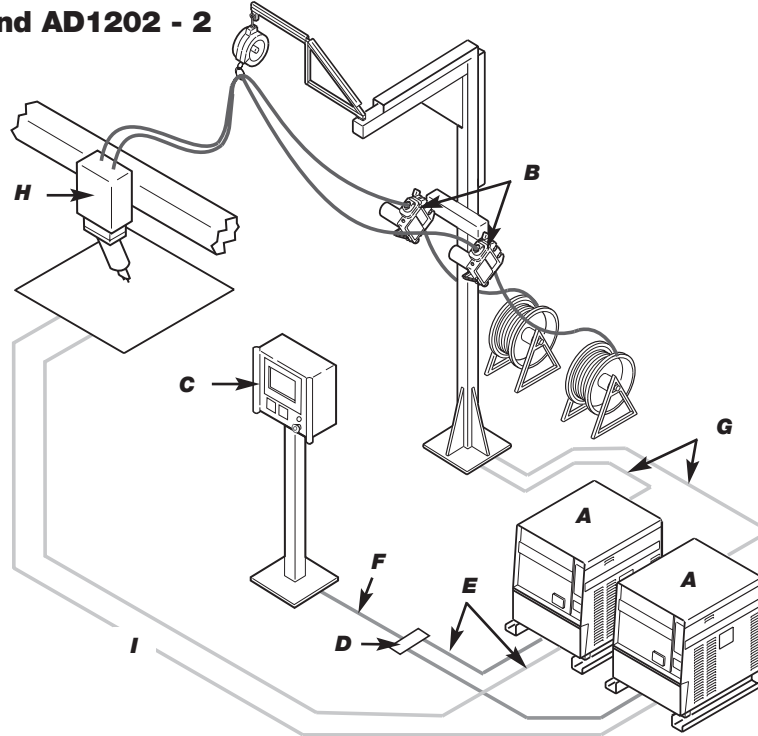

Item	Component	AD1202-1	AD1202-2	Qty
A	Power Source Tandem MIG Power Wave 455M Robotic or Tandem MIG Power Wave 655 Robotic	K2262-1-TM	K1519-1-TM	2
B	Wire Feeder Power Feed 10R Wire Feeder	K1780-2	K1780-2	2
C	Interface Controller	G3207-185	G3207-185	1
D	DeviceNet Tee	S23383-3	S23383-3	2
	Terminating Resistor	S23383-5	S23383-5	1
E	DeviceNet Communication Cables (drops) (20 in.)	S23383-4	S23383-4	2
F	DeviceNet Communication Cables (trunk line) (19.5 ft.)	S23383-2	S23383-2	1
G	Communication cables. Power source to wire feeders (25 ft.)	K1785-25	K1795-25	2
	Cable jumper, 22 pin to 14 pin (18 inch)		K1804-2	2
H	800 amp Tandem MIG torch or 900 amp Tandem MIG torch	S22693-XXX or G3494-XA	S22693-XXX or G3494-XA	1
I	4/0 Work (ground) cable (25 ft.)	L-4/0-25-14-14	L-4/0-25-14-14	2
Not Shown	Drive Roll Kit	KP1505-XX	KP1505-XX	2
Not Shown	Wire Straightener	K1733-1	K1733-1	2
Not Shown	Process Sense Leads	K940-25	K940-25	2
Not Shown	4/0 Electrode Cable (25 ft.)	L-4/0-25-14-14	L-4/0-25-14-14	2
Not Shown	Torch water cooling package	AD1013-3	AD1013-3	1 or 3*

* S22693-XXX series torches require (1) water cooling package per torch, G3494-XA series torches require (3)

Tandem MIG

High-Speed and High-Deposition Welding

Configuring Tandem MIG

Robotic Systems

Models: AD1201 - 1 and AD1201 - 2

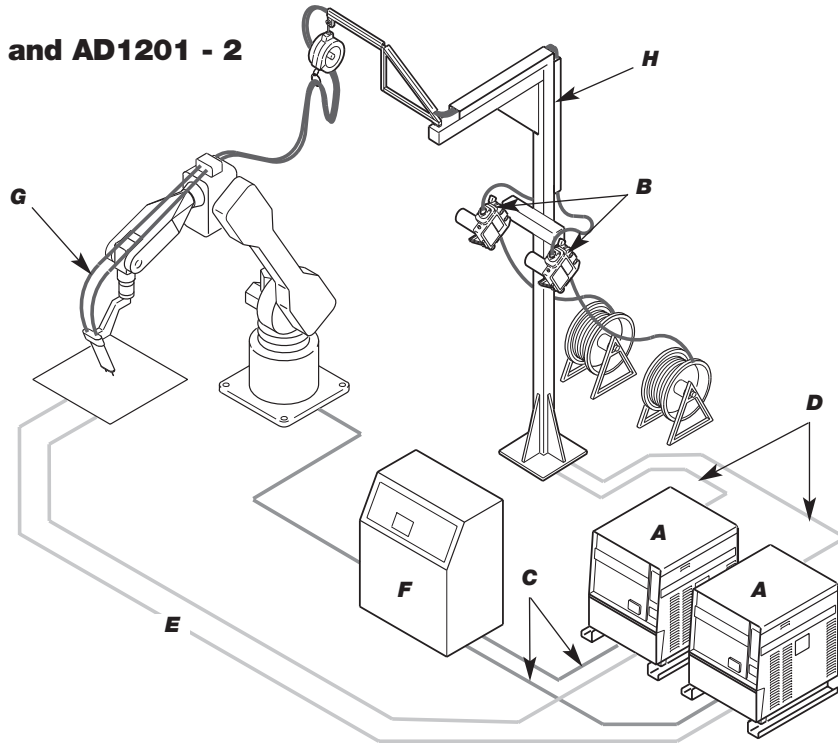

Item	Component	AD1201-1	AD1201-2	Qty
A	Power Source Tandem MIG Power Wave 455M Robotic or	K2262-1-TM		2
A	Tandem MIG Power Wave 655 Robotic		K1519-1-TM	2
B	Wire feeder Power Feed 10R wire feeder	K1780-2	K1780-2	2
C	ArcLink cables, Power source to robot controller (25 ft.)	S23394-18	S23394-18	2
D	Communication cables, Power source to wire feeders (25 ft.)	K1785-25	K1795-25	2
	Cable jumper, 22-pin to 14-pin (18 in.)		K1804-2	2
E	4/0 Work (ground) cable (25 ft.)	L-4/0-25-14-14	L-4/0-25-14-14	2
F	Fanuc RJ3iB robot and controller Arc tool software 6.4 or above	100 or 120 Series RJ3iB Controller	100 or 120 Series RJ3iB Controller	1
	Dual channel DeviceNet board	S23319-62	S23319-62	1
	24 Volt Power cable	S23394-9	S233394-9	1
G	800 amp Tandem MIG torch or 900 amp Tandem MIG torch	S22693-XXX or G3494-XA	S22693-XXX or G3494-XA	1
H	9 ft. Boom for wire feeder mounting	AD1038-3	AD1038-3	1
Not Shown	Reaming Station	M18426-1	M18426-1	1
Not Shown	Drive Roll Kit	KP1505-XX	KP1505-XX	2
Not Shown	Wire Straightener	K1733-1	K1733-1	2
Not Shown	Process Sense Leads	K940-25	K940-25	2
Not Shown	4/0 Electrode Cable (25 ft.)	L-4/0-25-14-14	L-4/0-25-14-14	2
Not Shown	Torch water cooling package	AD1013-3	AD1013-3	1 or 3*

* S22693-XXX series torches require (1) water cooling package per torch, G3494-XA series torches require (3)

Tandem MIG

14/16

High-Speed and High-Deposition Welding

Lincoln Welding Systems Featuring Tandem MIG



Power Feed 10R Wire Feeder

Compact Wire Drive System for Automation

The Power Feed 10R is a high performance, digitally controlled wire feeder designed to be a part of a modular, multi-process welding system. It is specifically designed to mount to a robot arm or to use in hard automation applications. Modular systems can be arranged in a variety of ways for optimum, customized performance and easy maintenance. This four drive roll feeder operates on 40VDC input power and is designed to be used with ArcLink™ Robotic Power Wave® power sources. Close integration of the feeder, power source and existing equipment creates the foundation for a system with superior welding performance and reliability.

Patented Drive Roll System

The Power Feed 10R is a basic wire feeder with an optimized design, which consists of an industrial motor driving the feeder mechanism in a sheet metal frame. The logic for controlling the wire feeder resides in a PC board inside the robotic power source.

Advantage Lincoln

- Digitally controlled by the Power Wave power source, yielding the best performance in the industry.
- Use with Lincoln power sources featuring ArcLink, the leading digital communications protocol for welding, making it the best choice for seamless integration with the power source and networked equipment.
- Tachometer feedback provides calibrated and precise control of wire feed speed.
- Feeder brakes from maximum speed to zero in milliseconds, minimizing the chance of wire sticking in the puddle.
- Select standard or high speed gears for wide wire feed speed range.
- Split wire guides provide trouble-free feeding and offer fast, tool-less wire installation, changeover and maintenance.
- Easy-to-read gauge for accurate drive roll tension.
- Brass-to-brass connections for good connectivity between feeder and gun.
- Modular construction for easy servicing.
- Self loading wire feature for easy set-up.

T h e f u t u r e o f w e l d i n g i s h e r e .®

Tandem MIG

15/16

High-Speed and High-Deposition Welding

Lincoln Welding Systems Featuring Tandem MIG



Power Wave 455M

For welding thicker materials in robotics, hard automation, PLC and semiautomatic applications, choose the Power Wave 455M. The power source features Waveform Control Technology for superior arc performance on a variety of materials, including steel, stainless steel, aluminum and nickel alloys. Custom control of the arc for each wire type and size provide consistent welds time after time. These Power Waves are designed to be part of a modular, multi-process welding system.

Power Wave 655R

The Power Wave 655R was designed for Robotic and Hard Automation applications that require extra power (650 Amps at 100% Duty Cycle).

- Digital Communications enable the Power Wave to connect seamlessly to robot controllers and hard automation PLCs.
- The Ethernet/DeviceNet Gateway provides networking capabilities and allows process and production monitoring.
- Software-based controls can be upgraded as new features become available.
- The Power Wave 655R has an output range of 20-880 Amps.

Tandem MIG

16/16

High-Speed and High-Deposition Welding

Lincoln Consumables used with Tandem MIG

SuperArc®/SuperGlide®

Lincoln's SuperArc, our premium copper-coated MIG wire, and SuperGlide, our premium bare wire, are the choice of welders and welding decision-makers everywhere because of their exceptional consistency, feedability, and arc action.

A better arc means less spatter, less clean-up, and improved productivity – and premium SuperArc and SuperGlide deliver the best arc in MIG welding.

Our MicroGuard™ Ultra surface treatment, with proprietary arc enhancement agents, facilitates excellent weld puddle control, very good wetting action, straight bead edges, and a wider operating range.

The exceptional feeding characteristics of SuperGlide, made possible by MicroGuard Ultra surface treatment, translate to reduced down-time and high operator appeal.



Accu-Pak®

100% Recyclable Patented Package — when the wire is consumed, just remove the components, collapse the box and throw into the recycle bin. Lifting Strap for ease of movement from one location to the next. Patented Ring Design.



Accu-Trak®

This Accu-Trak Drum Payoff Kit is made of a durable plastic for superior strength and integrity. It also features two viewing windows 180° apart from one another for easy viewing of the wire as it is paying off.



A Payoff Kit must be used with Accu-Trak Drums to ensure precise feeding. The fitting on top of the Payoff Kit has a 1/2-14 NPT internal pipe thread to facilitate the connection of the conduit to 500 lb. Accu-Trak drums.

Customer Assistance Policy

The business of The Lincoln Electric Company is manufacturing and selling high quality welding equipment, consumables, and cutting equipment. Our challenge is to meet the needs of our customer and to exceed their expectations. On occasion, purchasers may ask Lincoln Electric for advice or information about their use of our products. We respond to our customers based on the best information in our possession at that time. Lincoln Electric is not in a position to warrant or guarantee such advice, and assumes no liability, with respect to such information or advice. We expressly disclaim any warranty of any kind, including any warranty of fitness for any customer's particular purpose, with respect to such information or advice. As a matter of practical consideration, we also cannot assume any responsibility for updating or correcting any such information or advice once it has been given, nor does the provision of information or advice create, expand or alter any warranty with respect to the sale of our products.

Lincoln Electric is a responsive manufacturer, but the selection and use of specific products sold by Lincoln Electric is solely within the control of, and remains the sole responsibility of the customer. Many variables beyond the control of Lincoln Electric affect the results obtained in applying these types of fabrication methods and service requirement.

Subject to change - This information is accurate to the best of our knowledge at the time of printing. Please refer to www.lincolnelectric.com for any updated information.

WHAT IS NEXTWELD?

The challenges facing industrial fabricators today are increasingly difficult. Rising labor, material, and energy costs, intense domestic and global competition, a dwindling pool of skilled workers, more stringent and specific quality demands.

Through our commitment to extensive research and investments in product development,

Lincoln Electric has established an industry benchmark for applying technology to improve the quality, lower the cost and enhance the performance of arc welding processes. Advancements in power electronics, digital communications and Waveform Control Technology™ are the foundation for many of the improvements. NEXTWELD brings you a series of Process, Technology, Application and Success Story documents like this one. NEXTWELD explains how technologies, products, processes and applications are linked together to answer the important questions that all businesses face:

- *How can we work faster, smarter, more efficiently?*
- *How can we get equipment and people to perform in ways they've never had to before?*
- *How do we stay competitive?*

NEXTWELD is the future of welding but its benefits are available to you today. Ask your Lincoln Electric representative how to improve the flexibility, efficiency and quality of your welding operations to reduce your cost of fabrication.

LINCOLN
ELECTRIC
THE WELDING EXPERTSSM

THE LINCOLN ELECTRIC COMPANY
www.lincolnelectric.com
1.216.481.8100



Free Manuals Download Website

<http://myh66.com>

<http://usermanuals.us>

<http://www.somanuals.com>

<http://www.4manuals.cc>

<http://www.manual-lib.com>

<http://www.404manual.com>

<http://www.luxmanual.com>

<http://aubethermostatmanual.com>

Golf course search by state

<http://golfingnear.com>

Email search by domain

<http://emailbydomain.com>

Auto manuals search

<http://auto.somanuals.com>

TV manuals search

<http://tv.somanuals.com>