

# DF-31/EC

## DOOR/WINDOW SENSOR

For Use with DF-16/EC Security Console

### Installation Instructions

**Linear**

(760) 438-7000 • FAX (760) 438-7043  
www.linearcorp.com

#### 1. SENSOR & MAGNET DETAIL

SENSOR HAS BUILT-IN SWITCH ON SIDE WITH NOTCH. MAGNET CAN ACTIVATE SWITCH UP TO 1/2" AWAY. WHEN MOUNTING SENSOR, ALIGN MAGNET TO NOTCH.

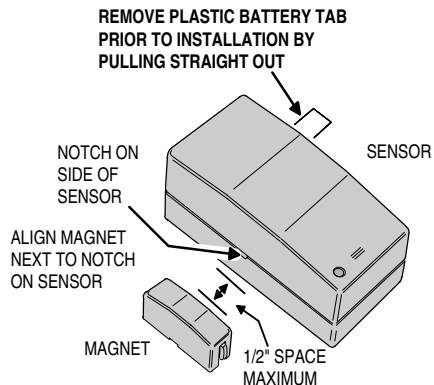

#### 2. SET SENSOR SWITCH

SET SWITCH TO DELAYED FOR ENTRY/EXIT DOOR

SET SWITCH TO INSTANT FOR WINDOWS OR NON-ENTRY DOORS

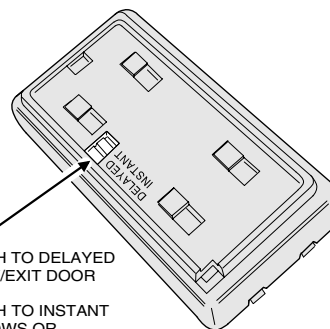

#### 3. EXAMPLE SENSOR LOCATIONS

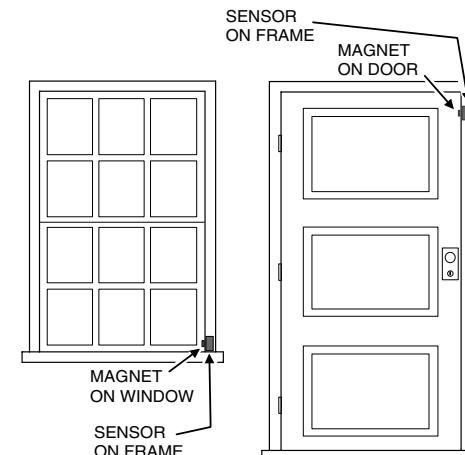

#### 4. PROGRAM SENSOR INTO CONSOLE

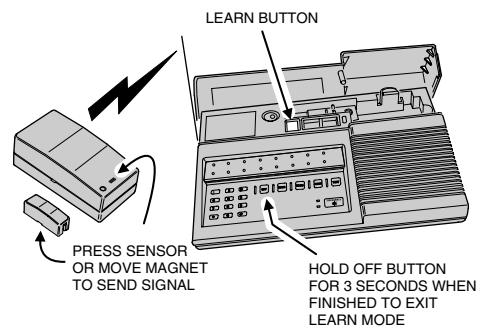
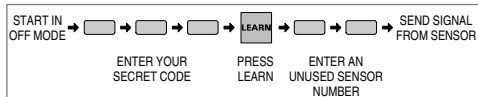

#### 5. EXAMPLE SENSOR MOUNTING ON DOOR

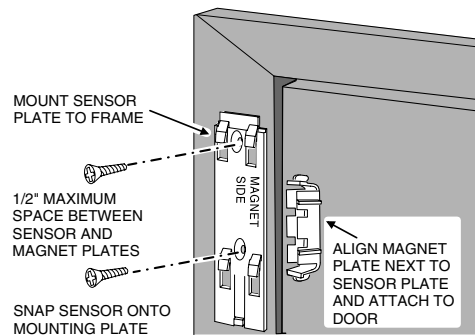

#### 6. EXAMPLE SENSOR MOUNTING ON WINDOW

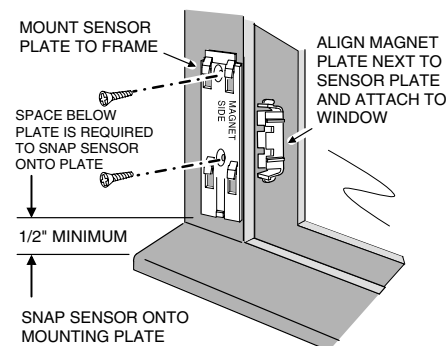

#### 7. OPTIONAL MAGNET SPACER

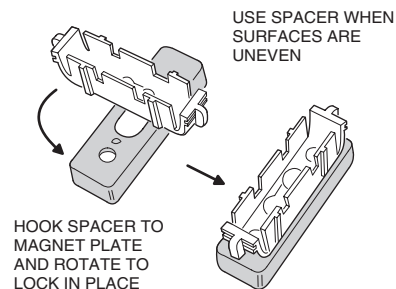

R&TTE VAAE 28357, EMC, SFT, ETS

Linear Corporation declares that the apparatus DF-31/EC complies with the essential requirements and other relevant provisions of Directive 1995/5/EC.

#### 8. TEST SENSOR

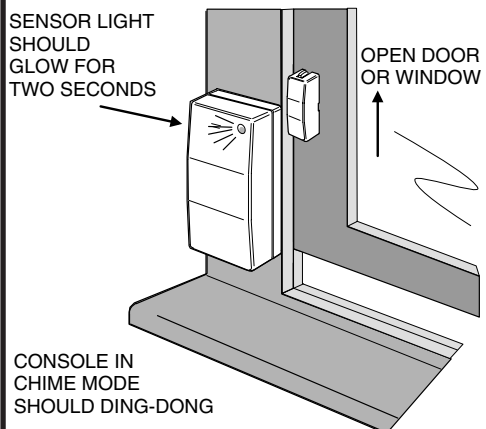

#### 9. LABEL SENSORS

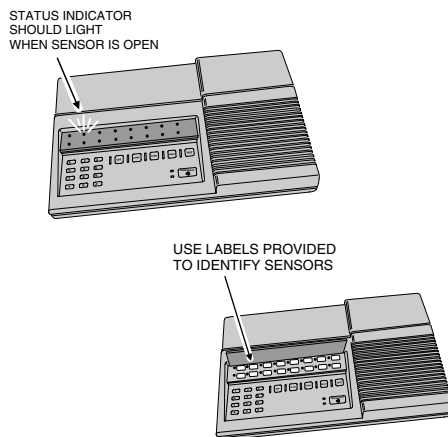

#### 10. CHANGING BATTERIES

WHEN CONSOLE INDICATES A SENSOR LOW BATTERY, OPEN SENSOR CASE AND GENTLY LIFT UP END OF BATTERY CLAMP, SLIDE BATTERIES OUT

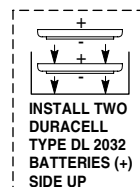
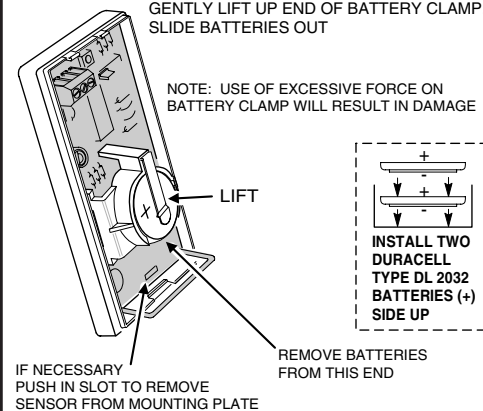

#### INTERNATIONAL WARRANTY

This Linear product is warranted against defects in material and workmanship for twelve (12) months. The Warranty Expiration Date is labeled on the product. This warranty extends only to wholesale customers who buy direct from Linear or through Linear's normal distribution channels. Linear does not warrant this product to consumers. Consumers should inquire from their selling dealer as to the nature of the dealer's warranty, if any. There are no obligations or liabilities on the part of Linear Corporation for consequential damages arising out of or in connection with use or performance of this product or other indirect damages with respect to loss of property, revenue, or profit, or cost of removal, installation, or reinstallation. All implied warranties, including implied warranties of merchantability and implied warranties of fitness, are valid only until Warranty Expiration Date as labeled on the product. This Linear Corporation Warranty is in lieu of all other warranties express or implied.

For warranty service on Linear equipment return product, at sender's expense to: Linear Hong Kong 19/F Hounor Industrial Centre, 6 Sun Yip Street, Chai Wan, Hong Kong Attention: Repairs Department

REPAIRS POLICY

Charges will be made for equipment that is not of warranty, shows customer abuse, or is damaged by the effects of lightning, water, fire, or other abnormal happenings.

Customer's equipment sent in for repair may be repaired or replaced with new or remanufactured equipment at Linear's discretion.

The customer is always responsible for shipping and handling charges to the repairs facility. Linear will pay return shipping and handling charges on "in warranty" products shipped back to the customer. The customer will be billed for the return shipping and handling charges on "out of warranty" products.

There will be a 50% expedite fee for any express requests.

The International Sales Manager must be notified prior to the return of product to Linear. All international returns must have an International Repair Authorization number (IRA#). The number must be marked on all packages. Failure to do so will cause delays in processing.

IMPORTANT !!!

Linear radio controls provide a reliable communications link and fill an important need in portable wireless signaling. However, there are some limitations which must be observed.

The radios are required to comply with local rules and regulations as radio devices. As such, they have limited transmitter power and therefore limited range.

A receiver cannot respond to more than one transmitted signal at a time and may be blocked by radio signals that occur on or near their operating frequencies, regardless of code settings.

Changes or modifications to the device may void regulatory compliance.

Frequently used radio links should be tested regularly to protect against undetected interference or fault.

A general knowledge of radio and its vagaries should be gained prior to acting as a wholesale distributor or dealer, and these facts should be communicated to the ultimate users.

## Free Manuals Download Website

<http://myh66.com>

<http://usermanuals.us>

<http://www.somanuals.com>

<http://www.4manuals.cc>

<http://www.manual-lib.com>

<http://www.404manual.com>

<http://www.luxmanual.com>

<http://aubethermostatmanual.com>

Golf course search by state

<http://golfingnear.com>

Email search by domain

<http://emailbydomain.com>

Auto manuals search

<http://auto.somanuals.com>

TV manuals search

<http://tv.somanuals.com>