

DXS-32/EC

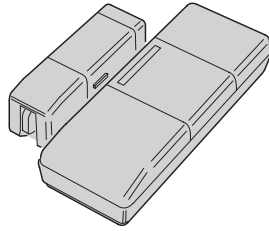

MINIATURE SUPERVISED DOOR/WINDOW TRANSMITTER

Installation Instructions



Linear®

(760) 438-7000 • FAX (760) 438-7043
www.linearcorp.com

PRODUCT DESCRIPTION

The DXS-32/EC is a battery powered stationary transmitter designed for use with Linear's DXS and DX format receivers. This transmitter can be used in a variety of wireless remote control applications. Triggering the transmitter with its built-in magnetic switch sends a digitally coded wireless signal to its companion receiver.

The digital DXS code format features over a million possible codes. The DXS transmitters are pre-coded at the factory to unique codes, so no field coding is required. The DXS-32/EC can send four different codes: alarm, restore, low battery and status.

Receivers must be programmed to the transmitter's code before system testing and operation. Refer to the receiver's instructions for details on programming.

In a typical installation, the magnet is mounted on a door or window and the transmitter is mounted on the frame. When the magnet moves more than 1 cm away from the transmitter, an alarm signal is sent. When the magnet returns next to the unit, a restore signal is sent. The magnet is adjustable with four height positions. A 0.5 cm high magnet spacer is also supplied to snap on to the base of the magnet.

The transmitter is powered from two 3-Volt #2032 lithium batteries with an expected battery life of up to 4 years. Every hour, the DXS-32/EC will send a status transmission to the receiver. The hourly signal updates the receiver to the transmitter's condition. By monitoring status transmissions, the receiver can determine if a transmitter has a low battery or has been removed from the system. DXS format receivers can monitor status signals, DX format receivers cannot.

Normally, the transmitter sends an exit/entry delay transmission code. Cutting an internal jumper selects an instant transmission code. Cutting this jumper doesn't change the time of the actual transmissions, but changes the code of the signal sent so the receiver can determine the transmitter's function.

DXS-32/EC FEATURES & ACCESSORIES

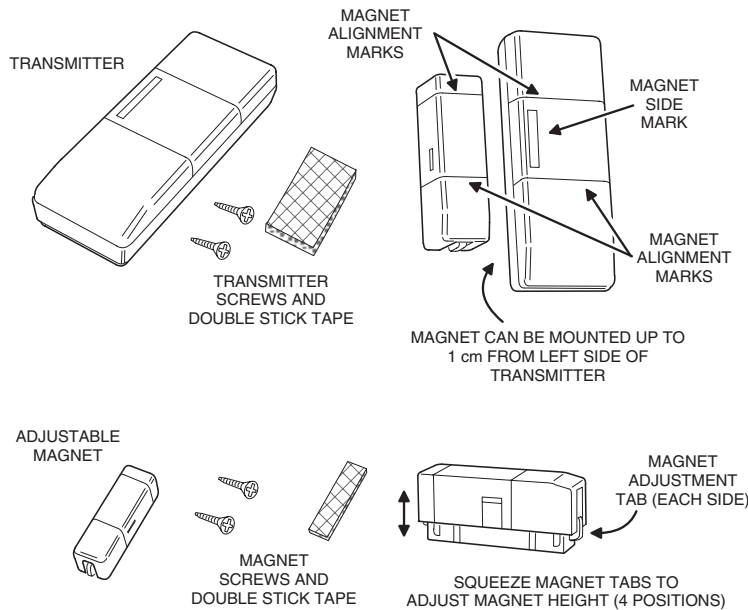

OPENING CASE

REMOVE THE CASE TOP BY TWISTING A SMALL FLAT BLADE SCREWDRIVER IN THE SLOT ON EITHER END OF THE TRANSMITTER

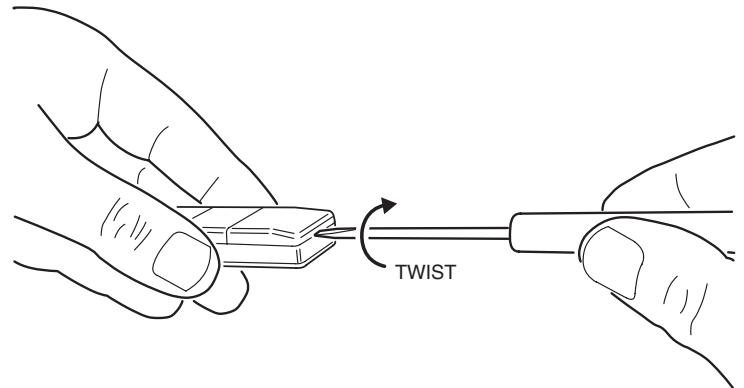

REMOVE BATTERY PROTECTION STRIP

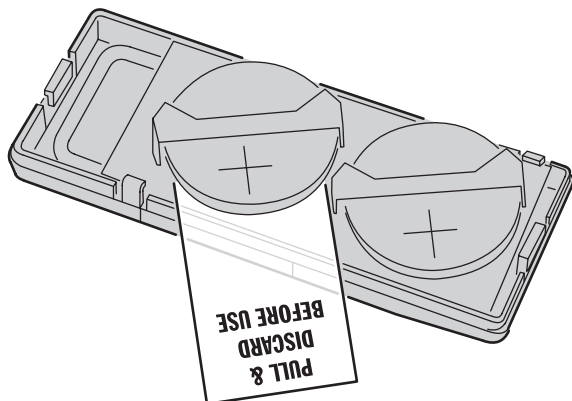

PULL OUT & DISCARD BATTERY PROTECTION STRIP TO ACTIVATE TRANSMITTER

COMPONENT LOCATIONS

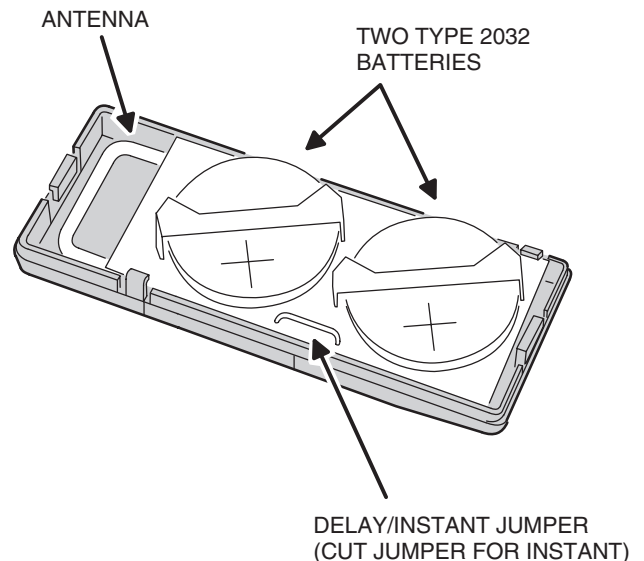

EXAMPLE INSTALLATIONS

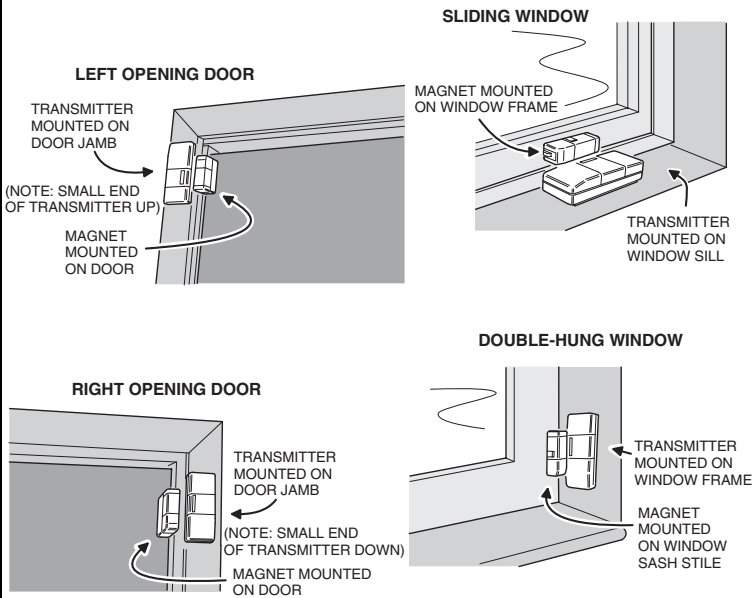

TRANSMITTER MOUNTING

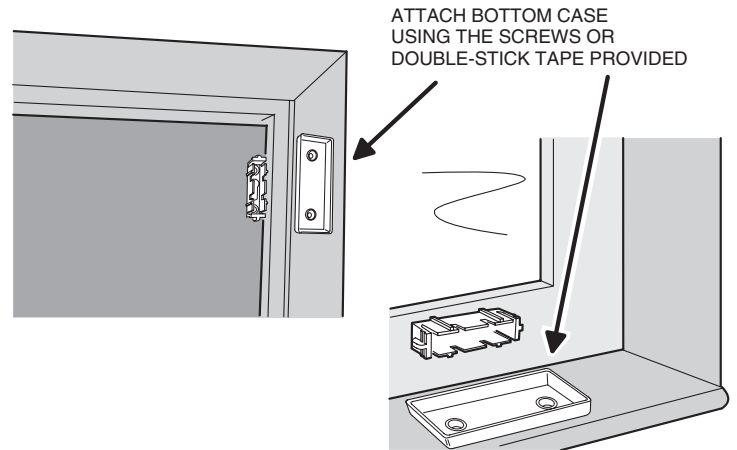

NOTE: ATTACHING THE TRANSMITTER WITH DOUBLE-STICK TAPE IS NOT ALLOWED IN UL INSTALLATIONS

ADJUSTING MAGNET HEIGHT

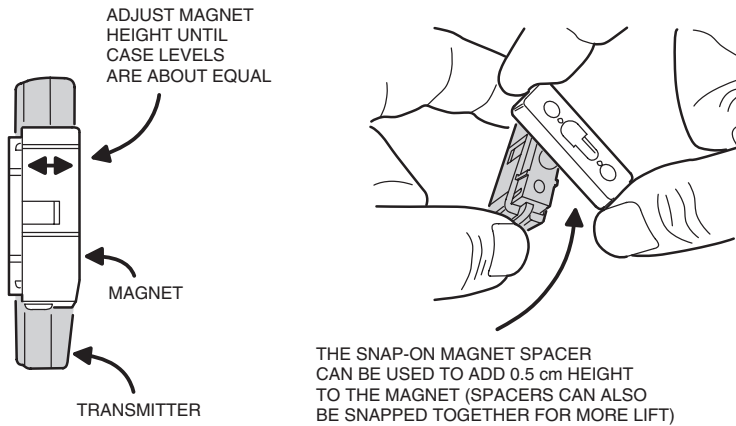

R&TTE VAAE 27836, EMC, SFT, ETS

Linear Corporation declares that the apparatus DXS-32/EC complies with the essential requirements and other relevant provisions of Directive 1995/5/EC.

PROGRAMMING RECEIVER

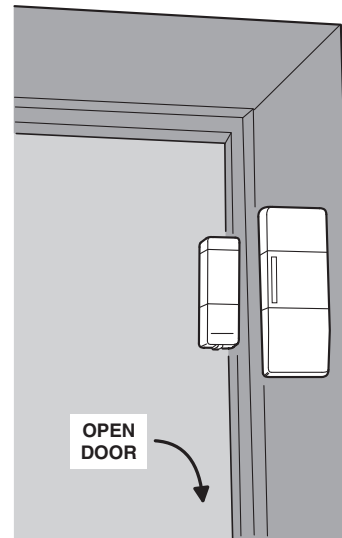

PROGRAMMING:

1. PLACE RECEIVER INTO PROGRAM OR "LEARNING" MODE
2. ACTIVATE TRANSMITTER BY OPENING DOOR OR WINDOW
3. VERIFY THAT THE RECEIVER ACCEPTED THE SIGNAL

TESTING:

1. PLACE RECEIVER INTO TEST MODE
2. OPEN DOOR, VERIFY THAT THE RECEIVER INDICATES AN OPEN DOOR
3. CLOSE DOOR, VERIFY THAT THE RECEIVER RECOGNIZED THAT THE DOOR IS CLOSED

CHANGING BATTERIES

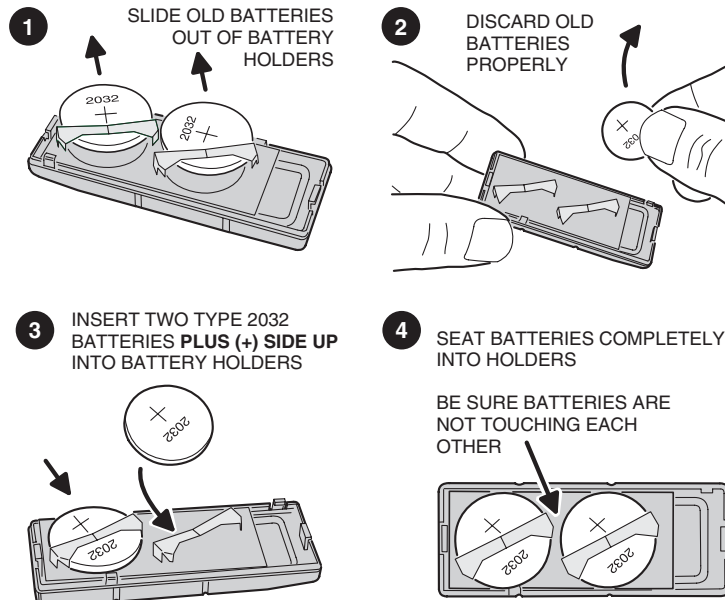

INTERNATIONAL WARRANTY

This Linear product is warranted against defects in material and workmanship for twelve (12) months. The Warranty Expiration Date is labeled on the product. **This warranty extends only to wholesale customers** who buy direct from Linear or through Linear's normal distribution channels. **Linear does not warrant this product to consumers.** Consumers should inquire from their selling dealer as to the nature of the dealer's warranty, if any. **There are no obligations or liabilities on the part of Linear Corporation for consequential damages arising out of or in connection with use or performance of this product or other indirect damages with respect to loss of property, revenue, or profit, or cost of removal, installation, or reinstallation.** All implied warranties, including implied warranties for merchantability and implied warranties for fitness, are valid only until Warranty Expiration Date as labeled on the product. **This Linear Corporation Warranty is in lieu of all other warranties express or implied.**

For warranty service on Linear equipment return product, at sender's expense to:

Linear Hong Kong
 19/F Hounor Industrial Centre
 6 Sun Yip Street
 Chai Wan, Hong Kong
 Attention: Repairs Department

REPAIRS POLICY

- * Charges will be made for equipment that is not in warranty, shows customer abuse, or is damaged by the effects of lightning, water, fire, or other abnormal happenings.
- * Customer's equipment sent in for repair may be repaired or replaced with new or remanufactured equipment at Linear's discretion.
- * The customer is always responsible for shipping and handling charges to the repairs facility. Linear will pay return shipping and handling charges on "in warranty" products shipped back to the customer. The customer will be billed for the return shipping and handling charges on "out of warranty" products.
- * There will be a 50% expedite fee for any express requests.
- * The International Sales Manager must be notified prior to the return of product to Linear. All international returns must have an International Repair Authorization number (IRA#). The number must be marked on all packages. Failure to do so will cause delays in processing.

IMPORTANT !!!

Linear radio controls provide a reliable communications link and fill an important need in portable wireless signaling. However, there are some limitations which must be observed.

- * The radios are required to comply with local rules and regulations as radio devices. As such, they have limited transmitter power and therefore limited range.
- * A receiver cannot respond to more than one transmitted signal at a time and may be blocked by radio signals that occur on or near their operating frequencies, regardless of code settings.
- * Changes or modifications to the device may void regulatory compliance.
- * Infrequently used radio links should be tested regularly to protect against undetected interference or fault.

Free Manuals Download Website

<http://myh66.com>

<http://usermanuals.us>

<http://www.somanuals.com>

<http://www.4manuals.cc>

<http://www.manual-lib.com>

<http://www.404manual.com>

<http://www.luxmanual.com>

<http://aubethermostatmanual.com>

Golf course search by state

<http://golfingnear.com>

Email search by domain

<http://emailbydomain.com>

Auto manuals search

<http://auto.somanuals.com>

TV manuals search

<http://tv.somanuals.com>