

*Instant EtherFast® Series*

# EtherFast® 8-Port and 12-Port Gigabit Ethernet Switches



Use this Guide to install the following products:

EF3508 EtherFast® 8-Port Gigabit Ethernet Switch

EF3512 EtherFast® 12-Port Gigabit Ethernet Switch

User Guide

 **LINKSYS®**

#### COPYRIGHT & TRADEMARKS

Copyright © 2002 Linksys, All Rights Reserved. EtherFast, Linksys, and Linksys logo are registered trademarks of Linksys Group, Inc. Microsoft, Windows, and the Windows logo are registered trademarks of Microsoft Corporation. All other trademarks and brand names are the property of their respective proprietors.

#### LIMITED WARRANTY

Linksys guarantees that every EtherFast® 8-Port Gigabit Ethernet Switch and EtherFast® 12-Port Gigabit Ethernet Switch is free from physical defects in material and workmanship under normal use for TWO years from the date of purchase. If the product proves defective during this warranty period, call Linksys Technical Support in order to obtain a Return Authorization number. BE SURE TO HAVE YOUR PROOF OF PURCHASE AND A BARCODE FROM THE PRODUCT'S PACKAGING ON HAND WHEN CALLING. RETURN REQUESTS CANNOT BE PROCESSED WITHOUT PROOF OF PURCHASE. When returning a product, mark the Return Authorization Number clearly on the outside of the package and include a copy of your original proof of purchase. All customers located outside of the United States of America and Canada shall be held responsible for shipping and handling charges.

IN NO EVENT SHALL LINKSYS' LIABILITY EXCEED THE PRICE PAID FOR THE PRODUCT FROM DIRECT, INDIRECT, SPECIAL, INCIDENTAL, OR CONSEQUENTIAL DAMAGES RESULTING FROM THE USE OF THE PRODUCT, ITS ACCOMPANYING SOFTWARE, OR ITS DOCUMENTATION. LINKSYS OFFERS NO REFUNDS FOR ITS PRODUCTS. TAMPERING WITH OR DISASSEMBLING THE PRODUCT VOIDS THE LINKSYS WARRANTY. Linksys makes no warranty or representation, expressed, implied, or statutory, with respect to its products or the contents or use of this documentation and all accompanying software, and specifically disclaims its quality, performance, merchantability, or fitness for any particular purpose. Linksys reserves the right to revise or update its products, software, or documentation without obligation to notify any individual or entity. Please direct all inquiries to:

Linksys P.O. Box 18558, Irvine, CA 92623.

#### FCC STATEMENT

The EtherFast® 8-Port Gigabit Ethernet Switch and EtherFast® 12-Port Gigabit Ethernet Switch have been tested and found to comply with the limits for a Class A digital device, pursuant to Part 15 of the FCC Rules. These limits are designed to provide reasonable protection against harmful interference in a residential installation. This equipment generates, uses, and can radiate radio frequency energy and, if not installed and used according to the instructions, may cause harmful interference to radio communications. However, there is no guarantee that interference will not occur in a particular installation. If this equipment does cause harmful interference to radio or television reception, which is found by turning the equipment off and on, the user is encouraged to try to correct the interference by one or more of the following measures:

- Reorient or relocate the receiving antenna
- Increase the separation between the equipment or device
- Connect the equipment to an outlet other than the receiver's
- Consult a dealer or an experienced radio/TV technician for assistance

UG-EF3508-EF3512-102202 NC BW

# Table of Contents

Chapter 1: Introduction	1
Your EtherFast® 8-Port and 12-Port Gigabit Switches	1
Features	1
Chapter 2: Getting to Know the EtherFast® 8-Port Gigabit Ethernet Switch	2
The 8-Port Gigabit Ethernet Switch's Back Panel	2
The 8-Port Gigabit Ethernet Switch's Front Panel	2
Chapter 3: Getting to Know the EtherFast® 12-Port Gigabit Ethernet Switch	4
The 12-Port Gigabit Ethernet Switch's Back Panel	4
The 12-Port Gigabit Ethernet Switch's Front Panel	4
Switches Versus Hubs	6
Chapter 4: Installing the EtherFast® Gigabit Ethernet Switches	7
Overview	7
Installing the 8-Port or 12-Port Gigabit Ethernet Switch	7
Connecting Your Hardware Together and Booting Up	7
Tips on Switching Your Network	8
Appendix A: Twisted-Pair Cabling	9
Crimping Your Own Network Cables	10
Appendix B: Glossary	11
Appendix C: Specifications for the EtherFast® 8-Port Gigabit Ethernet Switch	15
Environmental	15
Appendix D: Specifications for the EtherFast® 12-Port Gigabit Ethernet Switch	16
Environmental	16
Appendix E: Warranty Information	17
Appendix F: Contact Information	18

# Chapter 1: Introduction

## The EtherFast® 8-Port and 12-Port Gigabit Ethernet Switches

The EtherFast® 8-Port or 12-Port Gigabit Ethernet Switch takes your network to a whole new level of productivity—and does it using your existing architecture. There's no need to abandon your present equipment or radically change your way of doing things. This Switch from Linksys allows you to do what you already do—only faster!

Apply this switching power to your current Ethernet network, and your data traffic efficiency will improve several times over. Connect your Gigabit-equipped workstations to the Switch's 10/100/1000 ports for full-duplex, dedicated bandwidth of up to 1000Mbps!

With the EtherFast 8-Port or 12-Port Gigabit Ethernet Switch, you can connect your existing 10/100 Ethernet network to your Gigabit server backbone without any additional equipment. All ports are auto-sensing, and have auto MDI/MDIX. Address learning and aging is supported, as well as 802.3x flow control with head-of-line blocking prevention to keep your high-speed clients from bogging down in low-speed traffic.

The EtherFast 8-Port and 12-Port Gigabit Ethernet Switches from Linksys are the all-in-one solution for your Gigabit and 10/100 networking needs.

## Features

- Eight or twelve 10/100Mbps, half/full duplex, and 1000Mbps full duplex switched ports
- Forwards and filters packets at non-blocking, full wire speed
- All ports have auto-speed negotiation and MDI/MDIX
- Supports address learning and aging, 802.3x flow control, and head-of-line blocking prevention
- Free Technical Support—24 Hours a Day, 7 Days a Week Toll-Free US Calls
- Two-Year Limited Warranty

# Chapter 2: Getting to Know the EtherFast® 8-Port Gigabit Ethernet Switch

## The 8-Port Gigabit Ethernet Switch's Back Panel

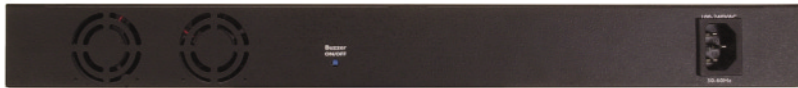

<b>FAN</b>	Radiates the heat inside the system.
<b>Buzzer</b>	Warns you if the system overheats. To disable the warning system, use a pen point or similar object to push in the button and the buzzer will not sound if the system overheats.
<b>Power</b>	The Power port is where you will connect the included power cord.

## The 8-Port Gigabit Ethernet Switch's Front Panel



<b>Ports 1-8</b>	These eight LAN (Local Area Network) ports connect network devices, such as PCs, print servers, network attached storage, and remote hard drives at 10/100/1000Mbps. Or, they can be used to expand your network by connecting to a 1000Mbps hub or switch. When connecting to a PC equipped with an Instant Gigabit Network Adapter, just plug one end of a Category 5e Ethernet network cable into the RJ-45 port on the Adapter and the other end into one of the ports on the Gigabit Ethernet Switch.
------------------	--

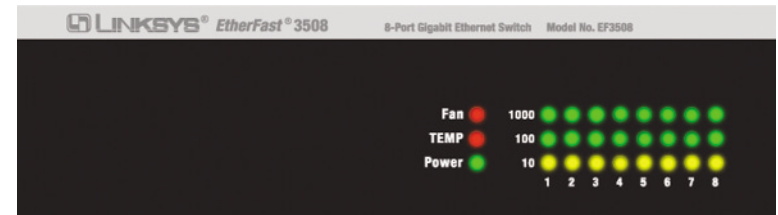

## The LED Indicators

<b>Fan</b>	<i>Red.</i> The Fan LED lights up when the fan is not on.
<b>TEMP</b>	<i>Red.</i> The TEMP LED lights up when the operating temperature is too high.
<b>Power</b>	<i>Green.</i> The Power LED lights up when the Switch is powered on.
<b>1000</b>	<i>Green.</i> The 1000 LED lights up when the port is operating at 1000Mbps. If the LED is off, the port is operating at either 100Mbps or 10Mbps, or it is not active.
<b>100</b>	<i>Green.</i> The 100 LED lights up when the port is operating at 100Mbps. If this LED is off, the port is operating at either 1000Mbps or 10Mbps, or it is not active.
<b>10</b>	<i>Amber.</i> The 10 LED lights up when the port is operating at 10Mbps. If this LED is off, the port is operating at either 1000Mbps or 100Mbps, or it is not active.
<b>FDX</b>	<i>Amber.</i> If the FDX (Full Duplex/Collision) LED is lit up continuously, the connection made through the corresponding port is running in Full Duplex mode. If the LED is blinking, the port is experiencing data collisions. Infrequent collisions are normal. If this LED is blinking often, there may be a problem with your connection.
<b>ACT</b>	<i>Green.</i> The ACT LED blinks when data is being sent or received through the port. When the LED is off, there is no data being transferred through the port.

# Chapter 3: Getting to Know the EtherFast® 12-Port Gigabit Ethernet Switch

## The 12-Port Gigabit Ethernet Switch's Back Panel



<b>FAN</b>	Radiates the heat inside the system.
<b>Buzzer</b>	Warns you if the system overheats. To disable the warning system, use a pen point or similar object to push in the button and the buzzer will not sound if the system overheats.
<b>Power</b>	The Power port is where you will connect the included power cord.

## The 12-Port Gigabit Ethernet Switch's Front Panel



<b>Ports 1-12</b>	These twelve LAN (Local Area Network) ports connect network devices, such as PCs, print servers, network attached storage, and remote hard drives at 10/100/1000Mbps. Or, they can be used to expand your network by connecting to a 1000Mbps hub or switch. When connecting to a PC equipped with an Instant Gigabit Network Adapter, just plug one end of a Category 5e Ethernet network cable into the RJ-45 port on the Adapter and the other end into one of the ports on the Gigabit Ethernet Switch.
-------------------	---

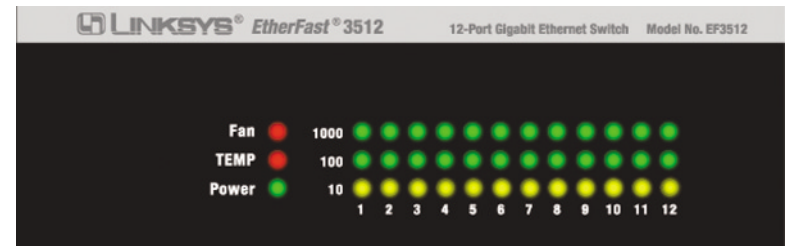

### The LED Indicators

<b>Fan</b>	<i>Red.</i> The Fan LED lights up when the fan is not on.
<b>TEMP</b>	<i>Red.</i> The TEMP LED lights up when the operating temperature is too high.
<b>Power</b>	<i>Green.</i> The Power LED lights up when the Switch is powered on.
<b>1000</b>	<i>Green.</i> The 1000 LED lights up when the port is operating at 1000Mbps. If the LED is off, the port is operating at either 100Mbps or 10Mbps, or it is not active.
<b>100</b>	<i>Green.</i> The 100 LED lights up when the port is operating at 100Mbps. If this LED is off, the port is operating at either 1000Mbps or 10Mbps, or it is not active.
<b>10</b>	<i>Amber.</i> The 10 LED lights up when the port is operating at 10Mbps. If this LED is off, the port is operating at either 1000Mbps or 100Mbps, or it is not active.
<b>FDX</b>	<i>Amber.</i> If the FDX (Full Duplex/Collision) LED is lit up continuously, the connection made through the corresponding port is running in Full Duplex mode. If the LED is blinking, the port is experiencing data collisions. Infrequent collisions are normal. If this LED is blinking often, there may be a problem with your connection.
<b>ACT</b>	<i>Green.</i> The ACT LED blinks when data is being sent or received through the port. When the LED is off, there is no data being transferred through the port.

## Switches Versus Hubs

The Gigabit Ethernet Switch boosts your network performance several times over, conserving your time, money and resources. The Switch's feature gives you a key advantage over other forms of networking by upgrading speed-critical network segments to 1000Mbps while allowing existing 10BaseT and 100BaseTX networks to operate with the Switch. Allowing 10BaseT and 100BaseTX hardware speeds to run alongside each other eliminates the need to purchase new hardware, rewire, and reconfigure an entire site all at once. This ensures that Fast Ethernet will not fall obsolete to upgrades in speed standards and maintains use of all your old equipment until you decide to buy speedier replacements.

Switches also feature full-duplex data transfer, meaning that all computers on the Switch can "talk" to the Switch at the same time. Plus, switches can send and receive data simultaneously to all connections, whereas a hub cannot. A hub simply works with one computer at a time and only sends or receives data, since it cannot handle two-way communication.

In addition to full-duplex transfer, the Switch provides your network with dedicated bandwidth to each node. For instance, if you connect eight computers to the EtherFast 8-Port Gigabit Ethernet Switch, then each computer will get a dedicated bandwidth of 2000Mbps at full duplex transfer. If you run eight computers from a 100Mbps hub, then each computer will share only a part of the 100Mbps bandwidth.

A network without a switch is called a shared network because every node on the network competes for a fraction of the total bandwidth. In a shared network, data packets are randomly broadcasted to all stations until they discover their intended destination. Consequently, considerable time and bandwidth is wasted on data packets swimming along network lines before they find their correct address. A switch, on the other hand, looks at the address for each data packet and delivers it directly to the correct destination.

Gigabit Ethernet is ideal for deployment as a backbone interconnect, and as a connection to high-performance servers. With the addition of Gigabit Ethernet, Ethernet delivers scalable solution (10/100/1000 Mbps) for the LAN from the desktop to the workgroup, and the backbone.

# Chapter 4: Installing the EtherFast® Gigabit Ethernet Switches

## Overview

Installing the EtherFast® Gigabit Ethernet Switch may involve installing both an adapter and the Gigabit Ethernet Switch. If you are integrating these items into an existing network, some additional steps may be necessary involving settings for your existing equipment. Consult your network administrator for more information about how the Gigabit Ethernet Switch will interface with your existing network components.

## Installing the Gigabit Ethernet Switches

The Switch's front panel has eight or twelve RJ-45 ports. Each 10/100/1000 port automatically detects the speed and duplex of the attached cabling to a network card, switch, hub, etc. The ports operate in either full or half duplex, which lets you run at speeds of 2000Mbps, 200Mbps, 100Mbps, or 10Mbps.

Each 10/100/1000 port on your Switch can connect to workstations, file servers, hubs, repeaters, bridges, routers or other switches. Connections to the switch require Category 5 Ethernet network cabling (Category 5e for Gigabit connections).

To connect a computer directly to the Switch, plug one end of a standard network cable into the switch, and then plug the other end of the cable into the computer's network adapter.

## Connecting Your Hardware Together and Booting Up

Plug in the Gigabit Ethernet Switch's power cable. The Power LED will light up. As devices make connections to the Switch's ports, each port's corresponding FDX or ACT LED will light up. The remaining LEDs will also light up according to how your connection is made, e.g. full or half duplex, 10Mbps, 100Mbps, or 1000Mbps.

If the Switch experiences excessive data collisions, verify that your network cabling is securely crimped and installed properly.

## Tips on Switching Your Network

Here are some of the ways the new EtherFast® 8-Port or 12-Port Gigabit Ethernet Switch can help you optimize your network speed.

- Speed up Nodes from Your 10BaseT Network

In a 10BaseT network, connect your hubs, file servers, and key users, such as network administrators, directly to your Switch to channel dedicated bandwidth in full-duplex mode (if operating in full-duplex) to each station. The Switch will have dedicated communication with all its connections simultaneously, whereas a hub will only communicate in half-duplex transfer mode and broadcasts information to all ports.

- Conserving Bandwidth with 10Mbps, 100Mbps and 1000Mbps Segments

10BaseT and 100BaseTX hardware are not readily compatible, but the Switch can designate network segments of different speeds. This allows you to run one 100Mbps segment to serve users without a need for considerable speed, and a faster 1000Mbps segment devoted to users who depend heavily on graphics, multimedia, database, or other speed-intensive applications. With switched segmentation, your 1000Mbps users will not be slowed down by the users on the 10/100Mbps segment.

- Run 10/100Mbps Peripherals in a 1000Mbps Network

Most of the network peripherals in place today run at 10/100Mbps, since 100BaseTX has been the standard network speed to date. These peripherals, designed to operate at 100Mbps, cannot readily communicate with 1000BaseTX equipment. A 10Mbps interface is also required for cable and DSL connections, which are quickly becoming very popular ways to access the Internet. The Switch provides your 10BaseT equipment and cable and DSL lines with a 10Mbps interface while still running your Fast Ethernet devices at 100Mbps or your Gigabit devices at 1000Mbps.

- Strengthen Data Transfers through Signal Regeneration

The Switch functions as a repeater, which regenerates data signals as they pass through it. This feature acts as a safeguard to deter data loss and ensure that transmissions arrive at their destination intact. Switches positioned between hubs can preserve your data's integrity and eliminate your need to buy and use repeaters in your Fast Ethernet or Gigabit network.

## Appendix A: Twisted-Pair Cabling

There are different grades, or categories, of twisted-pair cabling. Category 5 is the most reliable and is highly recommended. Straight-through cables are used for connecting computers to a hub or switch. Crossover cables are used for connecting a hub or switch to another hub or switch (there is an exception: some hubs and switches have a built-in uplink port that is crossed internally; this allows you to link or connect hubs or switches together with a straight-through cable instead).

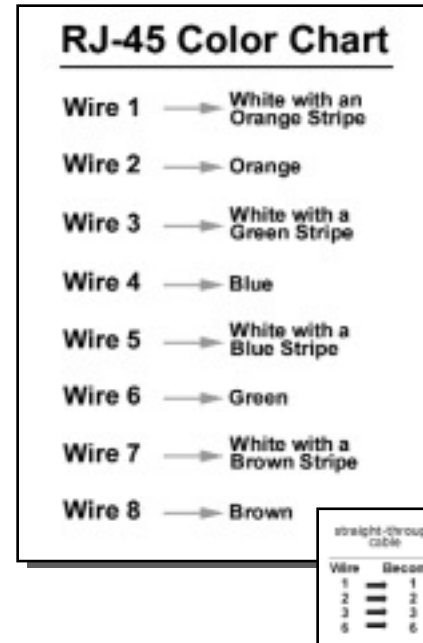

You can buy pre-made Category 5 or 5e cabling, or cut and crimp your own. Category 5 or 5e cables can be purchased or crimped as either straight-through or crossover. Inside a Category 5 or 5e cable are eight thin, color-coded wires that run from one end of the cable to the other. All eight wires are used. In a straight-through cable, wires 1, 2, 3, and 6 at one end of the cable are also wires 1, 2, 3, and 6 at the other end. In a crossover cable, the order of the wires change from one end to the other: wire 1 becomes 3, and 2 becomes 6. See the diagrams on the next page for more detailed information on straight-through and crossover cabling.

To determine which wire is wire number 1, hold the cable so that the end of the plastic RJ-45 connector (the part that goes into a wall jack first) is facing away from you. Face the clip down so that the copper side faces up (the springy clip will now be parallel to the floor). When looking down on the copper side, wire 1 will be on the far left.

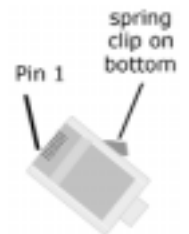

## Crimping Your Own Network Cables

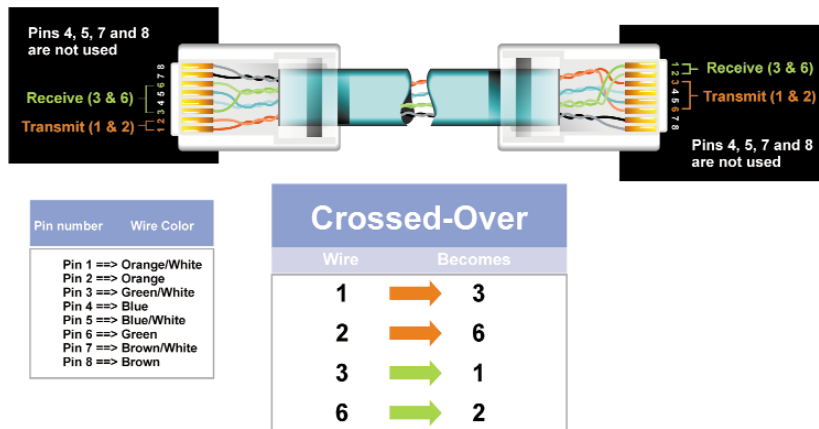
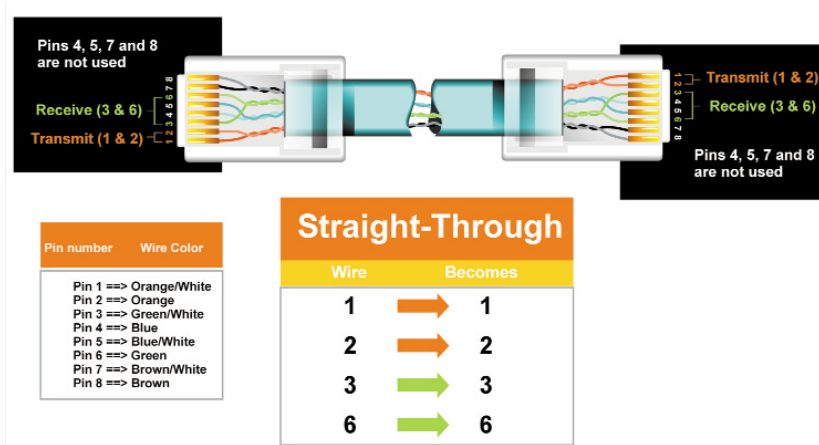

## Appendix B: Glossary

**10BaseT** - An Ethernet standard that uses twisted wire pairs.

**100BaseTX** - IEEE physical layer specification for 100 Mbps over two pairs of Category 5 UTP or STP wire.

**1000BASE-T** - Provides half-duplex (CSMA/CD) and full-duplex 1000Mbps Ethernet service over Category 5e links as defined by ANSI/TIA/EIA-568-A. Topology rules for 1000BASE-T are the same as those used for 100BASE-TX. Category 5e link lengths are limited to 100 meters by the ANSI/TIA/EIA-568-A cabling standard. Only one CSMA/CD repeater will be allowed in a collision domain.

**Adapter** - Printed circuit board that plugs into a PC to add to capabilities or connectivity to a PC. In a networked environment, a network interface card (NIC) is the typical adapter that allows the PC or server to connect to the intranet and/or Internet.

**Auto-MDI/MDIX** - On a network hub or switch, an auto-MDI/MDIX port automatically senses if it needs to act as a MDI or MDIX port. The auto-MDI/MDIX capability eliminates the need for crossover cables.

**Auto-Sensing** - To automatically determine the correct settings. The term is often used with communications and networking. For example, Ethernet 10/100 cards, hubs and switches can determine the highest speed of the node they are connected to and adjust their transmission rate accordingly.

**Backbone** - The part of a network that connects most of the systems and networks together and handles the most data.

**Bandwidth** - The transmission capacity of a given facility, in terms of how much data the facility can transmit in a fixed amount of time; expressed in bits per second (bps).

**CAT 3** - ANSI/EIA (American National Standards Institute/Electronic Industries Association) Standard 568 is one of several standards that specify "categories" (the singular is commonly referred to as "CAT") of twisted pair cabling systems (wires, junctions, and connectors) in terms of the data rates that they can sustain. CAT 3 cable has a maximum throughput of 16 Mbps and is usually utilized for 10BaseT networks.



**CAT 5** - ANSI/EIA (American National Standards Institute/Electronic Industries Association) Standard 568 is one of several standards that specify “categories” (the singular is commonly referred to as “CAT”) of twisted pair cabling systems (wires, junctions, and connectors) in terms of the data rates that they can sustain. CAT 5 cable has a maximum throughput of 100 Mbps and is usually utilized for 100BaseTX networks.

**CAT 5e** - The additional cabling performance parameters of return loss and far-end crosstalk (FEXT) specified for 1000BASE-T and not specified for 10BASE-T and 100BASE-TX are related to differences in the signaling implementation. 10BASE-T and 100BASE-TX signaling is unidirectional-signals are transmitted in one direction on a single wire pair. In contrast, Gigabit Ethernet is bi-directional-signals are transmitted simultaneously in both directions on the same wire pair; that is, both the transmit and receive pair occupy the same wire pair .

**Data Packet** - One frame in a packet-switched message. Most data communications is based on dividing the transmitted message into packets. For example, an Ethernet packet can be from 64 to 1518 bytes in length.

**Dynamic Routing** - The ability for a router to forward data via a different route based on the current conditions of the communications circuits. For example, it can adjust for overloaded traffic or failing lines and is much more flexible than static routing, which uses a fixed forwarding path.

**Ethernet** - IEEE standard network protocol that specifies how data is placed on and retrieved from a common transmission medium. Has a transfer rate of 10 Mbps. Forms the underlying transport vehicle used by several upper-level protocols, including TCP/IP and XNS.

**Fast Ethernet** - A 100 Mbps technology based on the 10BASE-T Ethernet CSMA/CD network access method.

**Full Duplex** - The ability of a device or line to transmit data simultaneously in both directions.

**Half Duplex** - Data transmission that can occur in two directions over a single line, but only one direction at a time.

**Hardware** - Hardware is the physical aspect of computers, telecommunications, and other information technology devices. The term arose as a way to distinguish the “box” and the electronic circuitry and components of a computer from the program you put in it to make it do things. The program came to be known as the software.

**Hub** - The device that serves as the central location for attaching wires from workstations. Can be passive, where there is no amplification of the signals; or active, where the hubs are used like repeaters to provide an extension of the cable that connects to a workstation.

**IEEE** - The Institute of Electrical and Electronics Engineers. The IEEE describes itself as “the world’s largest technical professional society – promoting the development and application of electrotechnology and allied sciences for the benefit of humanity, the advancement of the profession, and the well-being of our members.”

The IEEE fosters the development of standards that often become national and international standards. The organization publishes a number of journals, has many local chapters, and several large societies in special areas, such as the IEEE Computer Society.

**LAN** - A local area network (LAN) is a group of computers and associated devices that share a common communications line and typically share the resources of a single processor or server within a small geographic area (for example, within an office building).

**Latency** - The time delay between when the first bit of a packet is received and the last bit is forwarded.

**MAC (Media Access Control) Address** - A unique number assigned by the manufacturer to any Ethernet networking device, such as a network adapter, that allows the network to identify it at the hardware level.

**Mbps (Megabits Per Second)** - One million bits per second; unit of measurement for data transmission.

**MDI (Medium Dependent Interface)** - On a network hub or switch, a MDI port, also known as an uplink port, connects to another hub or switch using a straight-through cable. To connect a MDI port to a computer, use a crossover cable.

**MDIX (Medium Dependent Interface Crossed)** - On a network hub or switch, a MDIX port connects to a computer using a straight-through cable. To connect a MDIX port to another hub or switch, use a crossover cable.

**Network** - A system that transmits any combination of voice, video and/or data between users.

**NIC (Network Interface Card)** - A board installed in a computer system, usually a PC, to provide network communication capabilities to and from that computer system. Also called an adapter.

**Packet** - A unit of data routed between an origin and a destination in a network.

**Port** - A pathway into and out of the computer or a network device such as a switch or router. For example, the serial and parallel ports on a personal computer are external sockets for plugging in communications lines, modems and printers.

**RJ-45 (Registered Jack-45)** - A connector similar to a telephone connector that holds up to eight wires, used for connecting Ethernet devices.

**STP - (Shielded Twisted Pair)** Telephone wire that is wrapped in a metal sheath to eliminate external interference.

**TCP/IP (Transmission Control Protocol/Internet Protocol)** - The basic communication language or set of protocols for communications over a network (developed specifically for the Internet). TCP/IP defines a suite or group of protocols and not only TCP and IP.

**Throughput** - The amount of data moved successfully from one place to another in a given time period.

**UTP** - Unshielded twisted pair is the most common kind of copper telephone wiring. Twisted pair is the ordinary copper wire that connects home and many business computers to the telephone company. To reduce crosstalk or electromagnetic induction between pairs of wires, two insulated copper wires are twisted around each other. Each signal on twisted pair requires both wires. Since some telephone sets or desktop locations require multiple connections, twisted pair is sometimes installed in two or more pairs, all within a single cable.

## Appendix C: Specifications for the EtherFast® 8-Port Gigabit Ethernet Switch

<b>Standards</b>	IEEE 802.3, IEEE 802.3u, IEEE 802.3ab, IEEE 802.3x
<b>Protocol</b>	CSMA/CD
<b>Ports</b>	8 Auto-Sensing, Auto MDI/MDIX 10/100/1000 RJ-45 Ports
<b>Speed Per Port (Mbps)</b>	10 or 100 or 1000 (Half Duplex) 20 or 200 or 2000 (Full Duplex)
<b>MAC Addresses</b>	8K
<b>Buffer Memory</b>	512 KB
<b>Cabling Type</b>	Category 5e or Better (1000Mbps) Category 5 or Better (10/100Mbps)
<b>LEDs</b>	Power, TEMP, Fan Act (per Port), FDX (per Port) 10 (per Port), 100 (per Port), 1000 (per Port)

### Environmental

<b>Dimensions</b>	16.93" x 9.45" x 1.75" (430 mm x 240 mm x 44.5 mm)
<b>Unit Weight</b>	6.6 lbs. (3 kg)
<b>Power</b>	100-240 VAC, 50 W, 50-60Hz, 1A
<b>Certifications</b>	FCC Class A, CE
<b>Operating Temp.</b>	0°C to 40°C (32°F to 104°F)
<b>Storage Temp.</b>	-40°C to 70°C (-40°F to 158°F)
<b>Operating Humidity</b>	20% to 95%, Non-Condensing
<b>Storage Humidity</b>	20% to 95%, Non-Condensing

## Appendix D: Specifications for the EtherFast® 12-Port Gigabit Ethernet Switch

<b>Standards</b>	IEEE 802.3, IEEE 802.3u, IEEE 802.3ab, IEEE 802.3x
<b>Protocol</b>	CSMA/CD
<b>Ports</b>	12 Auto-Sensing, Auto MDI/MDIX 10/100/1000 RJ-45 Ports
<b>Speed Per Port (Mbps)</b>	10 or 100 or 1000 (Half Duplex) 20 or 200 or 2000 (Full Duplex)
<b>MAC Addresses</b>	32K
<b>Buffer Memory</b>	1 MB
<b>Cabling Type</b>	Category 5e or Better (1000Mbps) Category 5 or Better (10/100Mbps)
<b>LEDs</b>	Power, TEMP, Fan Act (per Port), FDX (per Port) 10 (per Port), 100 (per Port), 1000 (per Port)

### Environmental

<b>Dimensions</b>	16.93" x 9.45" x 1.75" (430 mm x 240 mm x 44.5 mm)
<b>Unit Weight</b>	7.9 lbs. (3.6 kg)
<b>Power</b>	100-240 VAC, 50 W, 50-60Hz, 1A
<b>Certifications</b>	FCC Class A, CE
<b>Operating Temp.</b>	0°C to 40°C (32°F to 104°F)
<b>Storage Temp.</b>	-40°C to 70°C (-40°F to 158°F)
<b>Operating Humidity</b>	20% to 95%, Non-Condensing
<b>Storage Humidity</b>	20% to 95%, Non-Condensing

## Appendix E: Warranty Information

BE SURE TO HAVE YOUR PROOF OF PURCHASE AND A BARCODE FROM THE PRODUCT'S PACKAGING ON HAND WHEN CALLING. RETURN REQUESTS CANNOT BE PROCESSED WITHOUT PROOF OF PURCHASE.

IN NO EVENT SHALL LINKSYS' LIABILITY EXCEED THE PRICE PAID FOR THE PRODUCT FROM DIRECT, INDIRECT, SPECIAL, INCIDENTAL, OR CONSEQUENTIAL DAMAGES RESULTING FROM THE USE OF THE PRODUCT, ITS ACCOMPANYING SOFTWARE, OR ITS DOCUMENTATION. LINKSYS DOES NOT OFFER REFUNDS FOR ANY PRODUCT.

LINKSYS OFFERS CROSS SHIPMENTS, A FASTER PROCESS FOR PROCESSING AND RECEIVING YOUR REPLACEMENT. LINKSYS PAYS FOR UPS GROUND ONLY. ALL CUSTOMERS LOCATED OUTSIDE OF THE UNITED STATES OF AMERICA AND CANADA SHALL BE HELD RESPONSIBLE FOR SHIPPING AND HANDLING CHARGES. PLEASE CALL LINKSYS FOR MORE DETAILS.

## Appendix F: Contact Information

For help with the installation or operation of the Switch, contact Linksys Technical Support at one of the phone numbers or Internet addresses below.

<b>Sales Information</b>	800-546-5797 (LINKSYS)
<b>Technical Support</b>	800-326-7114
<b>RMA Issues</b>	949-271-5461
<b>Fax</b>	949-265-6655
<b>Email</b>	support@linksys.com
<b>Web</b>	<a href="http://www.linksys.com">http://www.linksys.com</a>
<b>FTP Site</b>	<a href="ftp.linksys.com">ftp.linksys.com</a>



<http://www.linksys.com>

© Copyright 2002 Linksys, All Rights Reserved.

## Free Manuals Download Website

<http://myh66.com>

<http://usermanuals.us>

<http://www.somanuals.com>

<http://www.4manuals.cc>

<http://www.manual-lib.com>

<http://www.404manual.com>

<http://www.luxmanual.com>

<http://aubethermostatmanual.com>

Golf course search by state

<http://golfingnear.com>

Email search by domain

<http://emailbydomain.com>

Auto manuals search

<http://auto.somanuals.com>

TV manuals search

<http://tv.somanuals.com>